

KINTEK®

TOOLHOLDERS FOR CNC LATHES
PORTAUTENSILI PER TORNI CNC



TOOLHOLDERS FOR CNC LATHES

PORTAUTENSILI
PER TORNI CNC 

WERKZEUGHALTER FÜR
CNC-DREHEMASCHINEN 

PORTAHERRAMIENTAS
PARA TORNOS CNC 

PORTE-OUTILS
POUR TOURS CNC 

РЕЗЦЕДЕРЖАТЕЛИ ДЛЯ
ТОКАРНЫХ СТАНКОВ С ЧПУ 

数控车床刀柄 

- **DIN 69880** pagg. **320-346**
- **KIT** pag. **347**
- **SPARE PARTS** pagg. **348-355**
- **ACCESSORIES** pagg. **356-364**

DIN 69880

	A1 Pag. 326		B7 Pag. 330		E1 Pag. 335		HK1 Pag. 342
	A2 Pag. 326		B8 Pag. 330		E2 Pag. 336		M Pag. 343
	B1 Pag. 326		C1 Pag. 330		E3 Pag. 337		AR Pag. 344
	B2 Pag. 327		C1 Pag. 331		E2-TAG Pag. 337		AR Pag. 344
	B2 Pag. 327		C2 Pag. 331		E4 Pag. 339		ALU Pag. 344
	B2 Pag. 327		C2 Pag. 331		E7 Pag. 339		AL Pag. 345
	B3 Pag. 328		C3 Pag. 332		E8 Pag. 340		AL Pag. 345
	B3 Pag. 328		C3 Pag. 332		F Pag. 340		ARU Pag. 345
	B4 Pag. 328		C4 Pag. 332		MW Pag. 341		PU1 Pag. 346
	B4 Pag. 329		C4 Pag. 333		MW-AM Pag. 341		PU2 Pag. 346
	B5 Pag. 329		D1 Pag. 333		KS1 Pag. 342		KIT VDI Pag. 347
	B6 Pag. 329		D2 Pag. 335		KS2 Pag. 342		

**SPARE PARTS
RICAMBI**



PWZ
Pag. 349



833
Pag. 349

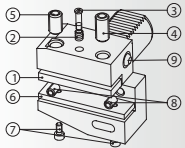

B1-B2-B3-B4
Pag. 350

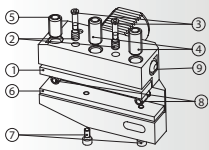

B5-B6-B7-B8
Pag. 351

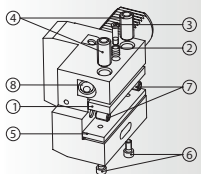

C1-C2-C3-C4
Pag. 352

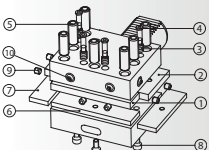

D1-D2
Pag. 353

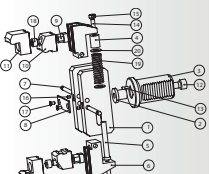

HK1
Pag. 354

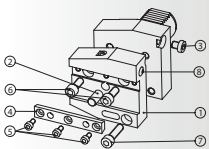

AR-AL-ARU-ALU
Pag. 355

**ACCESSORIES
ACCESSORI**



E2-1
Pag. 357



NC
Pag. 363



E2-3
Pag. 358



Z2
Pag. 363



114
Pag. 358



CW
Pag. 363



115-165
Pag. 359



CW-AM
Pag. 364



115-165
Pag. 360



**ASSEMBLY
SUPPORT**
Pag. 364



RZ
Pag. 361



165
Pag. 362



165
Pag. 362



DIN 69880



TOOL HOLDER WITH PARALLEL SHANK, TECHNICAL SPECIFICATIONS

WERKZEUGHALTER, ZYLINDERSCHAFT, TECHNISCHE HINWEISE
 PORTAHERRAMIENTAS CON MANGO CILINDRICO,
 CARACTERISTICAS TECNICAS
 КОНСТРУКТИВНЫЕ РАЗМЕРЫ РЕЗЦЕДЕРЖАТЕЛЕЙ
 С ХВОСТОВИКОМ VDI

PORTAUTENSILI CON CODOLO CILINDRICO
 SPECIFICHE TECNICHE
 PORTE-OUTIL AVEC QUEUE CYLINDRIQUE
 SPECIFICATIONS TECHNIQUES
 平行刀柄技术规格

DIN 69880

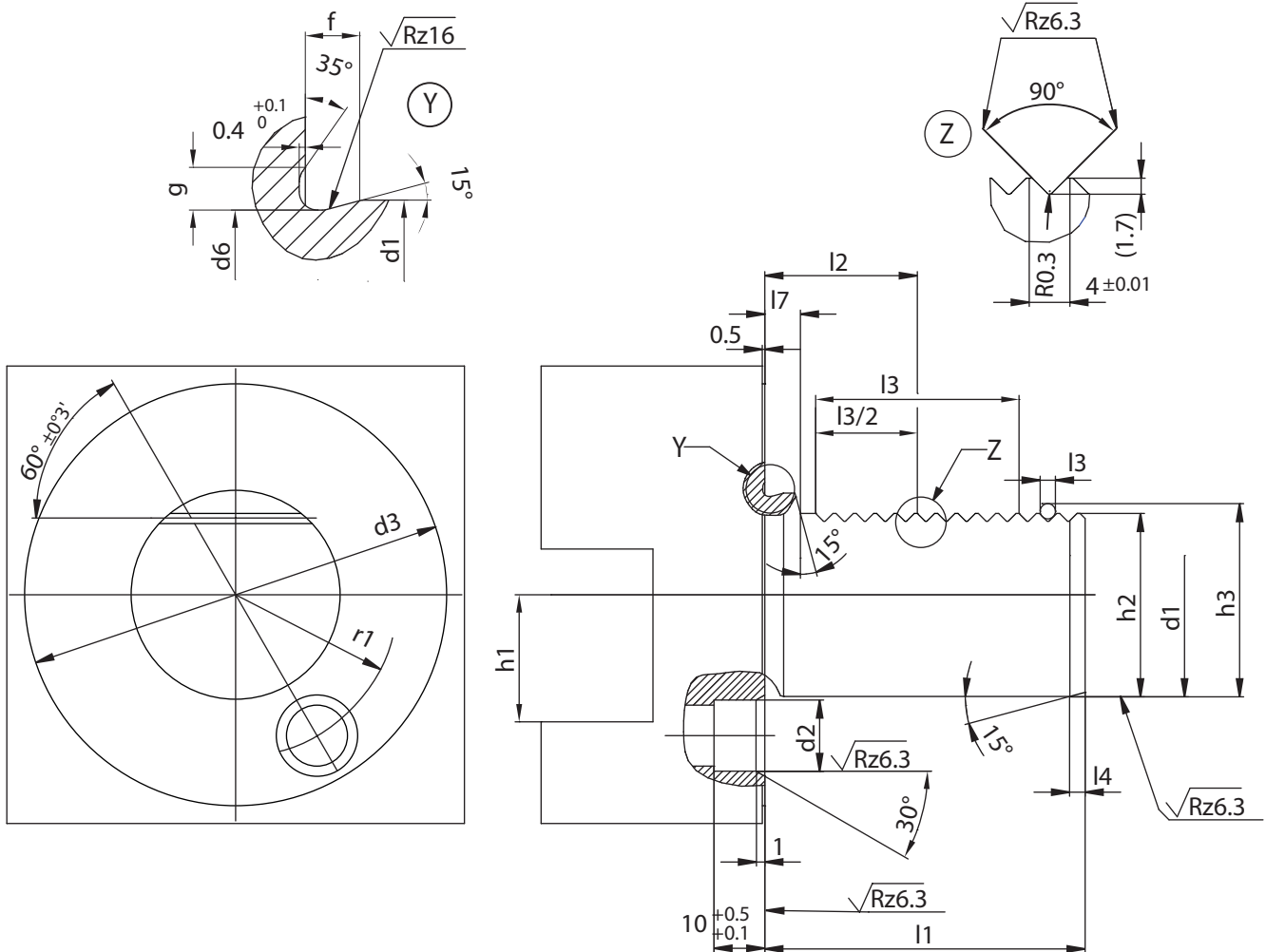

d1 h6	l1 ± 0.3	d2	d3	d6 -0.1	f	g	h1 max.	h2 ± 0.1	h3 ± 0.1	l2 ± 0.05	l3 min.	l4 +1	l7	r1 ± 0.02	o-ring
16	32	8 H6	40	15.4	2.0	1.7	12	15	16.92	12.7	16	2	3.5	14.5	15x1,5
20	40	10 H6	50	19.1	2.4	2	16	18	19.92	21.7	24	2	7	18	18,77x1,78
25	48	10 H6	58	24.1	2.4	2	16	23.5	25.42	21.7	24	2	7	21	23,52x1,78
30	55	14 H8	68	29.1	2.4	2	20	27	28.92	29.7	40	2	7	25	28,3x1,78
40	63	14 H8	83	38.7	3.7	2.8	25	36	37.92	29.7	40	3	7	32	37,77x2,62
50	78	16 H8	98	48.7	3.7	2.8	32	45	46.92	35.7	48	3	8	37	47,29x2,62
60	94	16 H8	123	58.7	4.3	3.7	32	55	56.92	43.7	56	4	10	48	56,74x3,53
80	124	20 H8	158	78.7	4.3	3.7	40	72	73.92	59.7	80	4	10	65	75,79x3,53

O-ring included in radial VDI
 O-ring incluso nei VDI radiali
 O-Ring incluidos en los VDI radiales
 O-Ring inbegriffen in den radialen VDI
 O-ring inclus dans les VDI radials
 В поставку с радиальным держателем включено кольцо
 O 令包含在径向 VDI 中

 **TOOLHOLDERS WITH CYLINDRICAL SHANK VDI** **TECHNICAL FEATURES**

All Kintek toolholders are manufactured according to **DIN 69880**.

CYLINDRICAL SHANK'S TOLERANCE - According to the class IT6 (h6)

COLLET CHUCK'S RUNOUT ACCURACY

- The norm DIN 69880-6 permits a runout error of 0,02 for DIN 6499 and DIN 6388 collet chucks
- Manufactured with casehardening steel with hardness HRC 58+-2, strenght 800-1000 N/mm2
- Internal diameters, shank and toothing are completely grinding finished

 **PORTAUTENSILI CON CODOLO CILINDRICO VDI** **DATI TECNICI**

Tutti i portautensili KINTEK vengono prodotti secondo le normative **DIN 69880**

TOLLERANZA DEL GAMBO CILINDRICO - Prodotti in classe IT6 (h6)

COASSIALITÀ PORTAPINZA

- La normativa DIN 69880-6 ammette un errore massimo di 0,02 sia per i portapinze DIN6499 che DIN 6388
- Costruiti in acciaio con durezza HRC 58+-2 resistenza 800-1000 N/ mm2
- Finitura di rettifica, interna, esterna, dentatura e nelle filettature delle ghiere chiudipinza

 **STEILKEGELAUFNAHMEN MIT VDI-ZYLINDRISCHEM SCHAFT** **TECHNISCHE DATEN**

Alle Kintek-Steilkegelaufnahmen werden nach den **din 69880-Normen** angefertigt.

TOLERANZEN VOM ZYLINDRISCHEN SCHAFT - In Klasse IT6 (h6) angefertigt.

RUNDLAUFGENAUIGKEIT DER SPANNZANGENAUFNAHME

- Die DIN 69880-6 Norm schreibt eine Rundlaufgenauigkeit zwischen Aussenkegel und Innenkegel Spannzangensitz von 0,02 vor
- Aus Stahl mit Härte HRC 58 +-2, Festigkeit 800-1000 N/mm2 angefertigt
- Inneres, äußeres Schleifen, auch an der Verzahnung und am Gewinde der Spannzangemutter

 **PORTAHERRAMIENTAS CON MANGO CILINDRICO VDI** **CARACTERISTICAS TECNICAS**

Todos los conos portaherramientas KINTEK son fabricados de acuerdo con las normativas **DIN 69880**

TOLERANCIA DEL MANGO CILINDRICO - Producidos en clase IT6 (h6)

CONCENTRICIDAD DE LOS PORTAPINZAS

- La normativa DIN69880-6 permite un error máximo de 0,02 tanto para los portapinzas DIN6499 como para los DIN6388
- Fabricados en acero con dureza HRC 58 +- 2, resistencia 800-1000N/mm2
- Rectificados en la parte anterior, interior, en el dentado y en el roscado de las tuercas de cierre

 **PORTE-OUTILS AVEC TIRETTE CILINDRIQUE VDI** **DONNEES TECHNIQUES**

Tous les porte-outils Kintek sont fabriqués selon les normes **DIN**

(qui prévoient les memes classes de tolérance pour les attachements DIN 69880).

TOLERANCE DE LA QUEUE CILINDRIQUE - Fabriqués en classe IT6 (h6)

COAXIALITÉ PORTE-PINCE

- La norme DIN 69880-6 admet une erreur de 0,02 maximun soit pour les porte-pinces DIN6499 que DIN6388
- Produits en acier cémenté allié avec dureté HRC 58+-2 résistance 800-1000 N/mm2
- Finition de rectification intérieur, extérieur, denture

 **РЕЗЦЕДЕРЖАТЕЛИ С ХВОСТОВИКОМ VDI** **ТЕХНИЧЕСКОЕ ОПИСАНИЕ**

Все резцедержатели Kintek изготовлены согласно **DIN 69880**

ТОЧНОСТЬ ХВОСТОВИКА - Соответствует классу IT6 (H6)

БИЕНИЕ ЦАНГОВЫХ ПАТРОНОВ

- В соответствии с нормами DIN 69880-6 биение цанговых патронов DIN 6499 и DIN 6388 составляет 0,02
- Изготовлены из стали с последующей цементацией, твердость 58+/-2 HRC, прочность 800-1000 Н/мм2
- Все внутренние диаметры, хвостовик и насечки отшлифованы

 **圆柱VDI刀柄** **技术特点**

所有 KINTEK 刀柄均是根据 **DIN69880** 标准制造的。

圆柱柄的误差 - 依据 IT6 (H6) 等级

弹簧夹头的径向跳动精度

- DIN 69880-6 标准允许 DIN 6499 和 DIN 6388 弹簧夹头的径向跳动误差为 0.02。
- 用表面硬化钢材制造，硬度达 HRC 58+-2，强度达 800-1000 N/平方毫米。
- 内径、柄和齿间均完全经过打磨处理

USE OF TOOLHOLDERS WITH CLOCKWISE SPINDLE ROTATION

ANWENDUNG VON WERKZEUGHALTERN MIT RECHTSLAUF
 USO DE LOS PORTAHERRAMIENTAS
 CON ROTACION HORARIA DEL PLATO
 ПРИМЕНЕНИЕ РЕЗЦЕДЕРЖАТЕЛЕЙ ПРИ
 ВРАЩЕНИИ ДЕТАЛИ ПО ЧАСОВОЙ СРЕЛКЕ

IMPIEGO DI PORTAUTENSILI
 CON ROTAZIONE ORARIA DEL MANDRINO
 EMPLOI DE PORTE-OUTILS AVEC
 ROTATION HORAIRE DE LA BROCHE
 轴逆时针旋转的刀柄的使用

DIN 69880

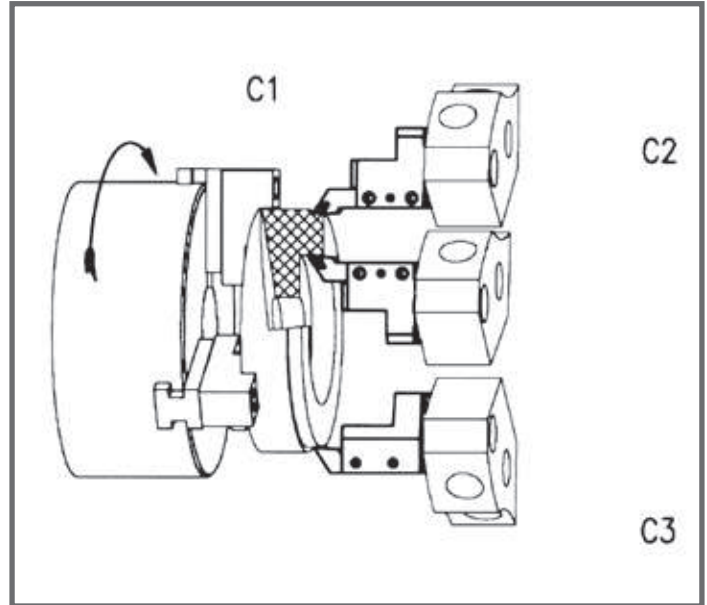
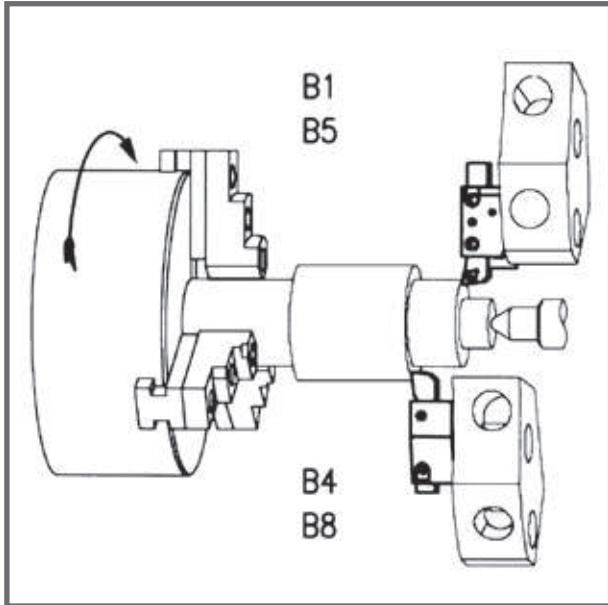

USE OF TOOLHOLDERS WITH COUNTERCLOCKWISE SPINDLE ROTATION

ANWENDUNG VON WERKZEUGHALTERN MIT LINKSLAUF
 USO DE LOS PORTAHERRAMIENTAS
 CON ROTACION ANTIHORARIA DEL PLATO
 ПРИМЕНЕНИЕ РЕЗЦЕДЕРЖАТЕЛЕЙ ПРИ ВРАЩЕНИИ
 ДЕТАЛИ ПРОТИВ ЧАСОВОЙ СРЕЛКИ

IMPIEGO DI PORTAUTENSILI CON ROTAZIONE
 ANTIORARIA DEL MANDRINO
 EMPLOI DE PORTE-OUTILS AVEC ROTATION
 ANTIHORAIRE DE LA BROCHE
 带逆时针旋转的刀柄用法

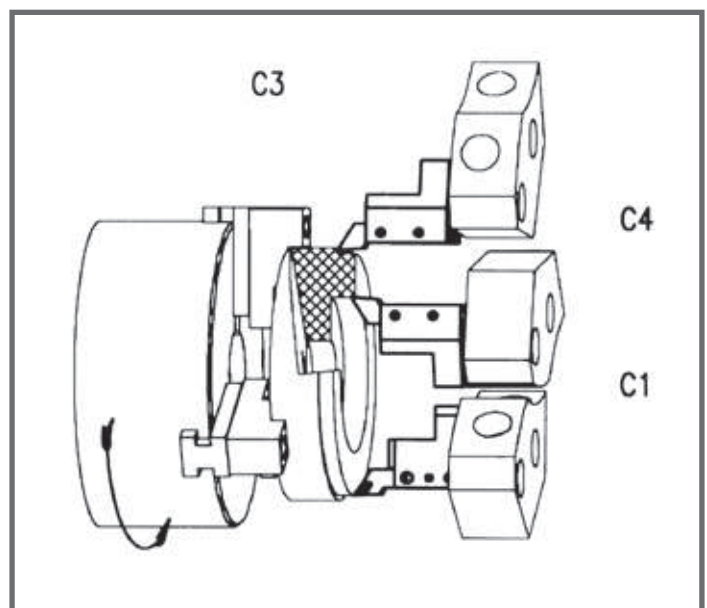
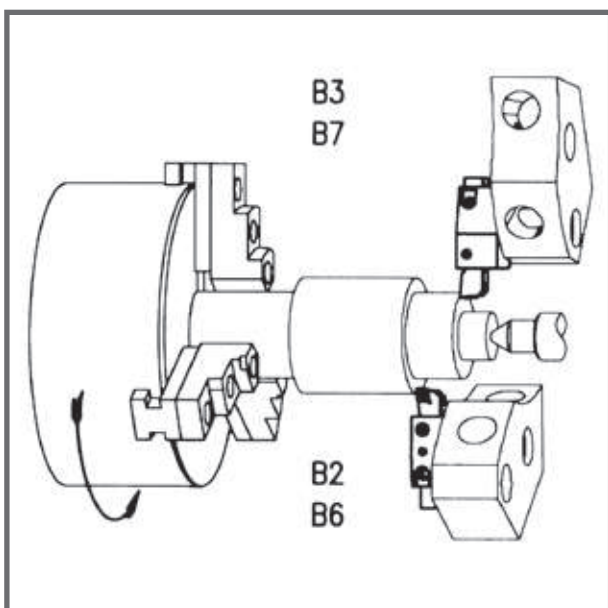

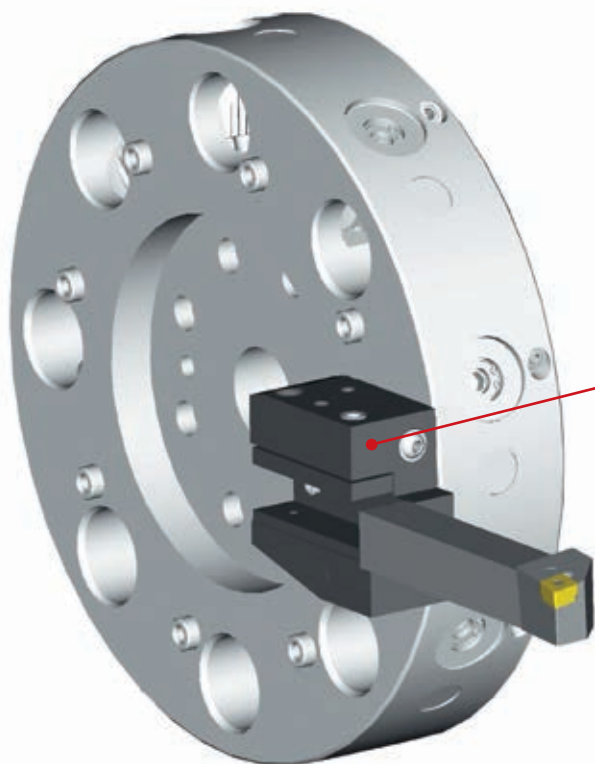

B1-40X25X44

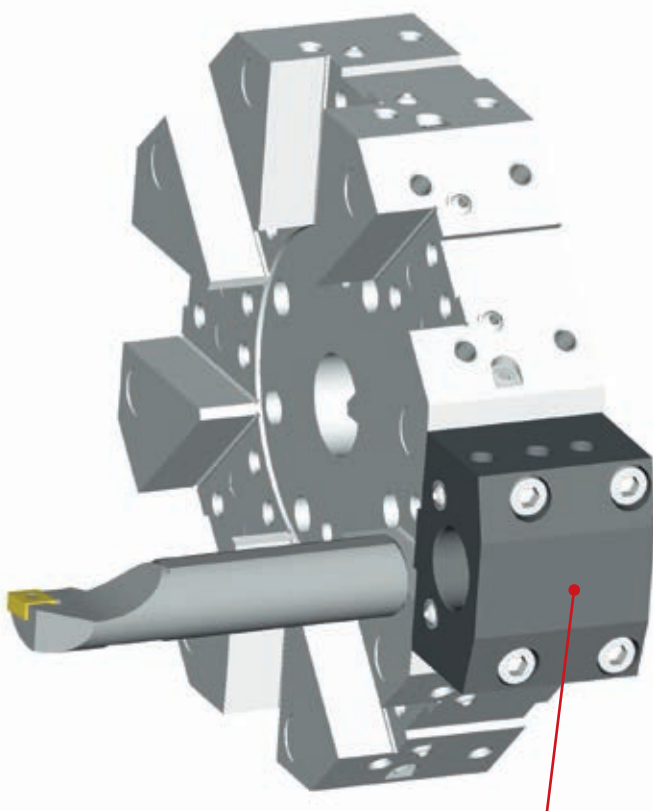

PU1-25X32

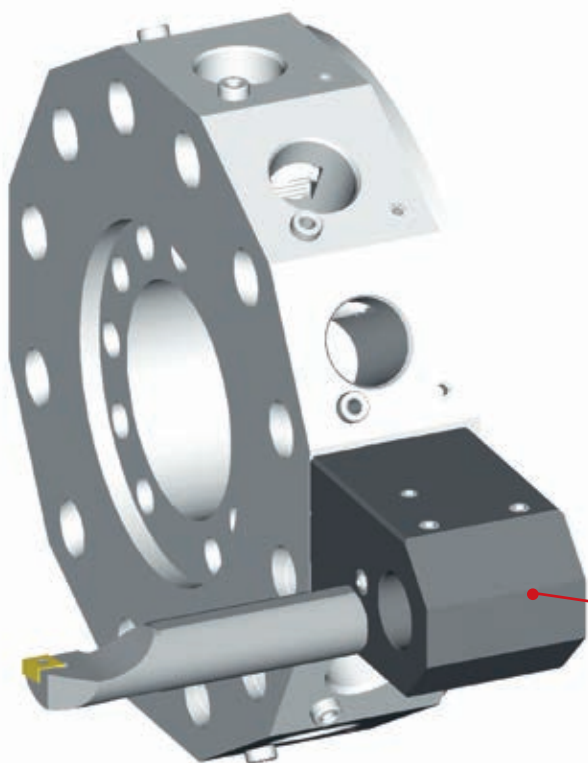

115-54061

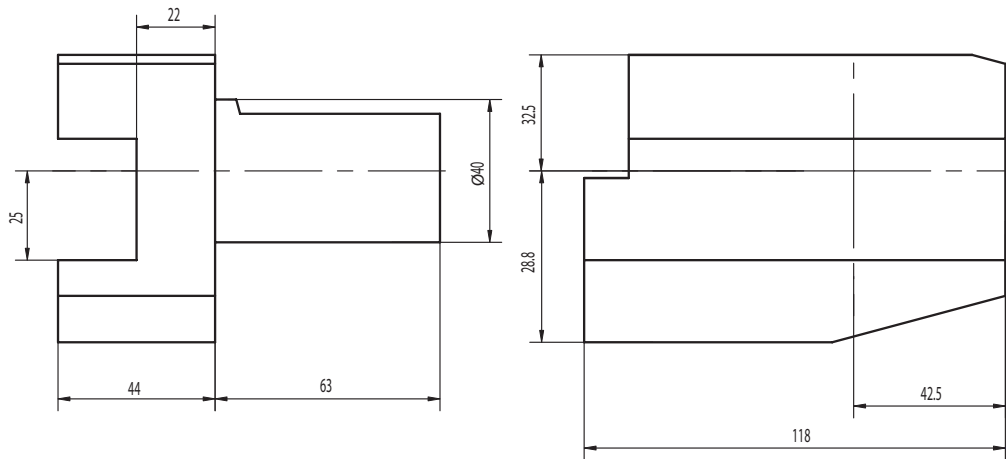
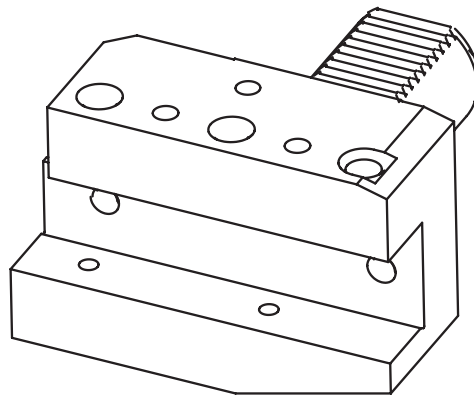

On request we can send you general layouts in dxf format with the relative dimensions.



Sono disponibili a richiesta i disegni di massima in formato dxf con relative quote di ingombro.



Auf Anfrage sind Dispositionszeichnungen im dxf-Format mit entsprechenden Massen verfügbar.



Están disponibles a petición los planos generales en formato dxf con los relativos tamaños



Sur demande les dessins d'avant-projet en format dxf sont disponibles avec les relatives cotes.



По запросу мы готовы выслать Вам общий чертеж в формате dxf с соответствующими размерами.



如有要求, 我们可以发送DXF格式的带有相关参数的总体设计。

RECTANGULAR BLANK FOR SPECIAL VERSIONS

VIERKANT-ROHLING FÜR SONDERAUSFÜHRUNGEN
PORTAHERRAMIENTAS SEMIACABADO RECTANGULAR
ПРИЗМАТИЧЕСКИЕ ЗАГОТОВКИ ДЛЯ СПЕЦИАЛЬНЫХ РЕЗЦЕДЕРЖАТЕЛЕЙ

PORTAUTENSILE PER VERSIONI SPECIALI RETTANGOLARE
EBAUCHE RECTANGULAIRE POUR VERSIONS SPECIALES
专用矩形柄

DIN 69880 - A1

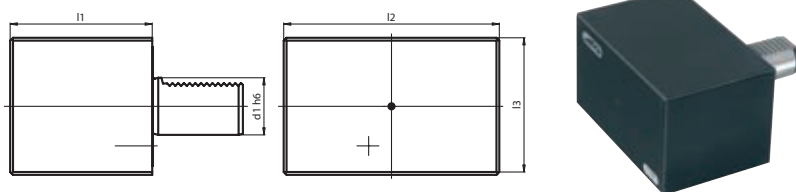

CODE N.	d1	l1	l2	l3
A1-30x85	30	85	130	76
A1-40x100	40	100	151	96
A1-50x125	50	125	160	120
A1-60x160	60	160	165	125

ROUND BLANK FOR SPECIAL VERSIONS

ZYLINDER-ROHLING FÜR SONDERAUSFÜHRUNGEN
PORTAHERRAMIENTAS SEMIACABADO REDONDO
ЦИЛИНДРИЧЕСКИЕ ЗАГОТОВКИ ДЛЯ СПЕЦИАЛЬНЫХ РЕЗЦЕДЕРЖАТЕЛЕЙ

PORTAUTENSILE PER VERSIONI SPECIALI ROTONDO
EBAUCHE CYLINDRIQUE POUR VERSIONS SPECIALES
专用圆形柄

DIN 69880 - A2

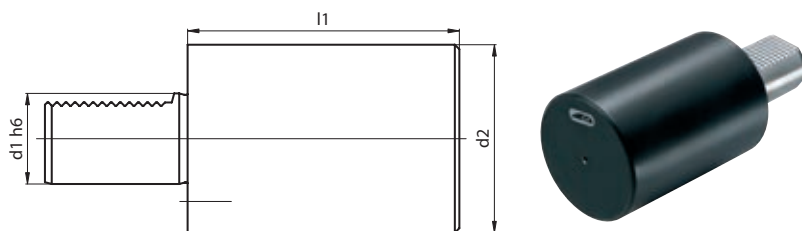

CODE N.	d1	d2	l1
A2-25x200	25	58	200
A2-30x100	30	68	100
A2-30x240	30	68	240
A2-40x120	40	83	120
A2-40x320	40	83	320
A2-50x135	50	98	135
A2-50x400	50	98	400
A2-60x150	60	123	150

RADIAL HOLDER, RH, SHORT

RADIAL WERKZEUGHALTER, RECHTS, KURZ
PORTAHERRAMIENTAS RADIAL, DCH, CORTO
РЕЗЦЕДЕРЖАТЕЛИ РАДИАЛЬНЫЕ ПРАВЫЕ. КОРОТКОЕ ИСПОЛНЕНИЕ.

PORTAUTENSILE CON SEDE TRASVERSALE RETTANGOLARE, DX CORTO
PORTE-OUTIL RADIAL DROIT, COURT
径向刀柄, RH, 短的

DIN 69880 - B1

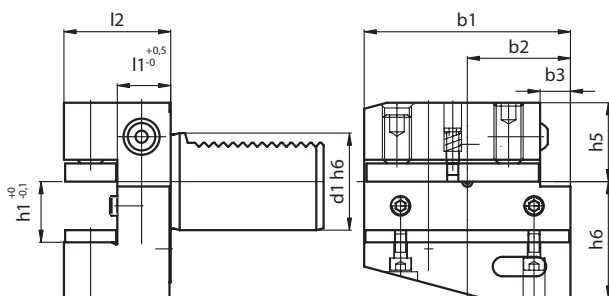

CODE N.	d1	b1	b2	b3	h1	h5	h6	l1	l2
B1-16x12x24	16	42	23	5	12	20	22	13	24
B1-20x16x30	20	55	30	7	16/12	25	30	16	30
B1-30x20x40	30	70	35	10	20/16	28	38	22	40
B1-30x20x60	30	70	35	10	20/16	28	38	42	60
B1-40x25x44	40	85	42.5	12.5	25/20	32.5	48	22	44
B1-50x32x55	50	100	50	16	32/25	35	60	30	55
B1-60x32x60	60	125	62.5	16	32/25	42.5	62.5	30	60

Spare parts on page 350 - Vedi ricambi a pag. 350 - Ver las piezas de repuesto a la pág. 350
S. Ersatzteile auf Seite 350 - Voyez les pièces détachées à la page 350
Запасные части на стр. 350 - 附件部分见 350 页

RADIAL HOLDER, RH, SHORT

RADIAL WERKZEUGHALTER, RECHTS, KURZ PORTAUTENSILE CON SEDE TRASVERSALE RETTANGOLARE, DX CORTO
 PORTAHERRAMIENTAS RADIAL, DCH, CORTO
 РЕЗЦЕДЕРЖАТЕЛИ РАДИАЛЬНЫЕ ПРАВЫЕ. КОРОТКОЕ ИСПОЛНЕНИЕ. PORTE-OUTIL RADIAL DROIT, COURT
 径向刀柄, RH, 短的

DIN 69880 - B2

DIN 69880-B1

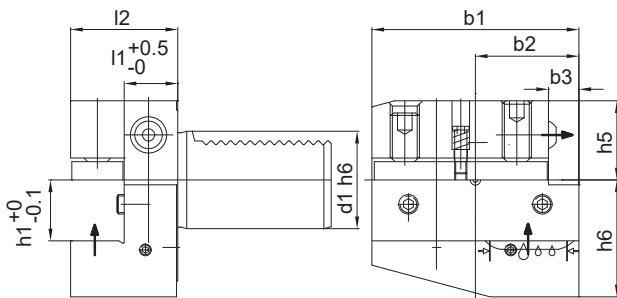

CODE N.	D1	b1	b2	b3	h1	h5	h6	l1	l2
B1-30x20x40-IC	30	70	35	10	20	28	38	22	40
B1-40x25x44-IC	40	85	42.5	12.5	25	32.5	48	22	44

Spare parts on page 350 - Vedi ricambi a pag. 350 - Ver las piezas de repuesto a la pág. 350
 S. Ersatzteile auf Seite 350 - Voyez les pièces détachées à la page 350
 Запасные части на стр. 350 - 附件部分见 350 页

RADIAL HOLDER, LH, SHORT

RADIAL WERKZEUGHALTER, LINKS, KURZ PORTAUTENSILE CON SEDE TRASVERSALE RETTANGOLARE, SX CORTO
 PORTAHERRAMIENTAS RADIAL, IZD, CORTO
 РЕЗЦЕДЕРЖАТЕЛИ РАДИАЛЬНЫЕ ЛЕВЫЕ. КОРОТКОЕ ИСПОЛНЕНИЕ. PORTE-OUTIL RADIAL GAUCHE, COURT
 径向刀柄, LH, 短的

DIN 69880 - B2

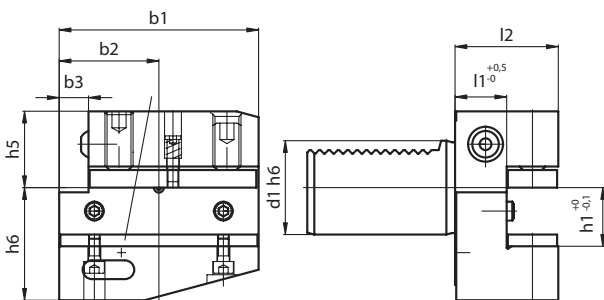

CODE N.	d1	b1	b2	b3	h1	h5	h6	l1	l2
B2-20x16x30	20	55	30	7	16/12	25	30	16	30
B2-30x20x40	30	70	35	10	20/16	28	38	22	40
B2-30x20x60	30	70	35	10	20/16	28	38	42	60
B2-40x25x44	40	85	42.5	12.5	25/20	32.5	48	22	44
B2-50x32x55	50	100	50	16	32/25	35	60	30	55
B2-60x32x60	60	125	62.5	16	32/25	42.5	62.5	30	60

Spare parts on page 350 - Vedi ricambi a pag. 350 - Ver las piezas de repuesto a la pág. 350
 S. Ersatzteile auf Seite 350 - Voyez les pièces détachées à la page 350
 Запасные части на стр. 350 - 附件部分见 350 页

RADIAL HOLDER, LH, SHORT

RADIAL WERKZEUGHALTER, LINKS, KURZ PORTAUTENSILE CON SEDE TRASVERSALE RETTANGOLARE, SX CORTO
 PORTAHERRAMIENTAS RADIAL, IZD, CORTO
 РЕЗЦЕДЕРЖАТЕЛИ РАДИАЛЬНЫЕ ЛЕВЫЕ. КОРОТКОЕ ИСПОЛНЕНИЕ. PORTE-OUTIL RADIAL GAUCHE, COURT
 径向刀柄, LH, 短的

DIN 69880 - B2

DIN 69880-B2

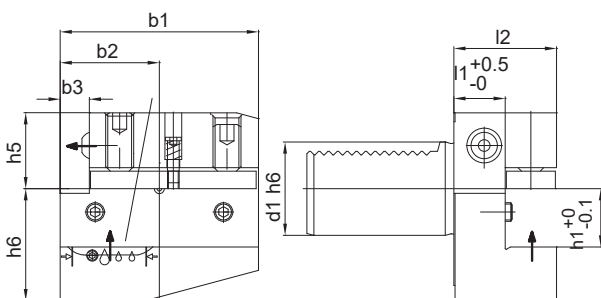

CODE N.	d1	b1	b2	b3	h1	h5	h6	l1	l2
B2-30x20x40-IC	30	70	35	10	20	28	38	22	40
B2-40x25x44-IC	40	85	42.5	12.5	25	32.5	48	22	44

Spare parts on page 350 - Vedi ricambi a pag. 350 - Ver las piezas de repuesto a la pág. 350
 S. Ersatzteile auf Seite 350 - Voyez les pièces détachées à la page 350
 Запасные части на стр. 350 - 附件部分见 350 页

RADIAL HOLDER, UPSIDE-DOWN, RH, SHORT

RADIAL WERKZEUGHALTER, ÜBERKOPF LINKS, KURZ
PORTAHERRAMIENTAS RADIAL, INVERTIDO, DCH, CORTO
РЕЗЦЕДЕРЖАТЕЛИ РАДИАЛЬНЫЕ ПЕРЕВЕРНУТЫЕ ПРАВЫЕ.
КОРОТКОЕ ИСПОЛНЕНИЕ.

PORTAUTENSILE CON SEDE TRASVERSALE
RETTANGOLARE, ROVESCiato DX CORTO
PORTE-OUTIL RADIAL RENVERSE, DROIT, COURT
徑向柄, 倒置, RH, 短

DIN 69880 - B3

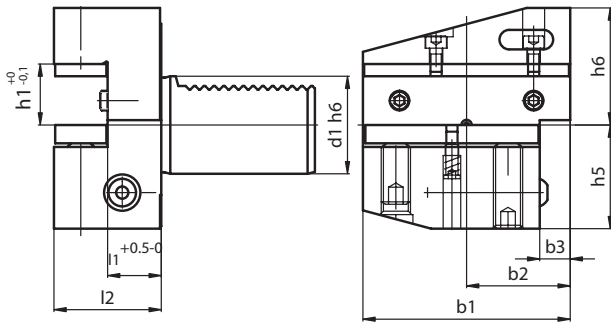

Spare parts on page 350 - Vedi ricambi a pag. 350 - Ver las piezas de repuesto a la pág. 350
S. Ersatzteile auf Seite 350 - Voyez les pièces détachées à la page 350
Запасные части на стр. 350 - 附件部分见 350 页

CODE N.	d1	b1	b2	b3	h1	h5	h6	l1	l2
B3-20x16x30	20	55	30	7	16/12	25	30	16	30
B3-20x16x40	20	55	30	7	16/12	25	30	26	40
B3-30x20x40	30	70	35	10	20/16	35	38	22	40
B3-40x25x44	40	85	42.5	12.5	25/20	42.5	48	22	44
B3-50x32x55	50	100	50	16	32/25	50	60	30	55
B3-60x32x60	60	125	62.5	16	32/25	62.5	62.5	30	60

RADIAL HOLDER, UPSIDE-DOWN, RH, SHORT

RADIAL WERKZEUGHALTER, ÜBERKOPF LINKS, KURZ
PORTAHERRAMIENTAS RADIAL, INVERTIDO, DCH, CORTO
РЕЗЦЕДЕРЖАТЕЛИ РАДИАЛЬНЫЕ ПЕРЕВЕРНУТЫЕ ПРАВЫЕ.
КОРОТКОЕ ИСПОЛНЕНИЕ.

PORTAUTENSILE CON SEDE TRASVERSALE
RETTANGOLARE, ROVESCiato DX CORTO
PORTE-OUTIL RADIAL RENVERSE, DROIT, COURT
徑向柄, 倒置, RH, 短

DIN 69880 - B3

DIN 69880-B3

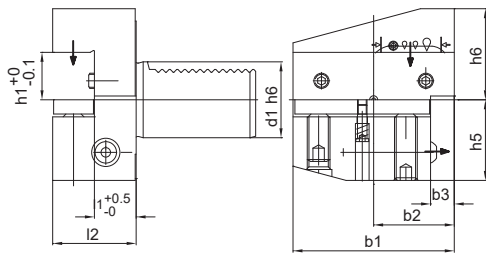

Spare parts on page 350 - Vedi ricambi a pag. 350 - Ver las piezas de repuesto a la pág. 350
S. Ersatzteile auf Seite 350 - Voyez les pièces détachées à la page 350
Запасные части на стр. 350 - 附件部分见 350 页

CODE N.	d1	b1	b2	b3	h1	h5	h6	l1	l2
B3-30x20x40-IC	30	70	35	10	20	35	38	22	40
B3-40x25x44-IC	40	85	42.5	12.5	25	42.5	48	22	44

RADIAL HOLDER, UPSIDE-DOWN, LH, SHORT

RADIAL WERKZEUGHALTER, ÜBERKOPF LINKS, KURZ
PORTAHERRAMIENTAS RADIAL, INVERTIDO, IZD, CORTO
РЕЗЦЕДЕРЖАТЕЛИ РАДИАЛЬНЫЕ ПЕРЕВЕРНУТЫЕ ЛЕВЫЕ.
КОРОТКОЕ ИСПОЛНЕНИЕ.

PORTAUTENSILE CON SEDE TRASVERSALE
RETTANGOLARE, ROVESCiato SX CORTO
PORTE-OUTIL RADIAL RENVERSE, GAUCHE, COURT
徑向柄, 倒置, LH, 短

DIN 69880 - B4

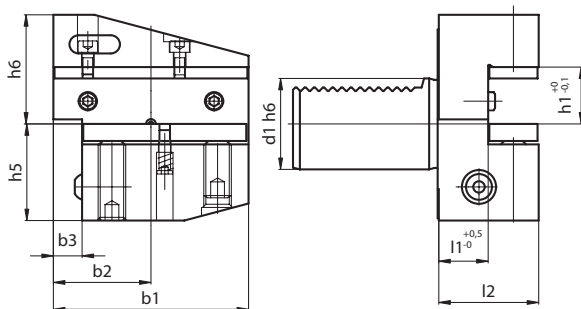

Spare parts on page 350 - Vedi ricambi a pag. 350 - Ver las piezas de repuesto a la pág. 350
S. Ersatzteile auf Seite 350 - Voyez les pièces détachées à la page 350
Запасные части на стр. 350 - 附件部分见 350 页

CODE N.	d1	b1	b2	b3	h1	h5	h6	l1	l2
B4-30x20x40	30	70	35	10	20/16	35	38	22	40
B4-40x25x44	40	85	42.5	12.5	25/20	42.5	48	22	44
B4-50x32x55	50	100	50	16	32/25	50	60	30	55
B4-60x32x60	60	125	62.5	16	32/25	62.5	62.5	30	60

RADIAL HOLDER, UPSIDE-DOWN, LH, SHORT

RADIAL WERKZEUGHALTER, ÜBERKOPF LINKS, KURZ
PORTAHERRAMIENTAS RADIAL, INVERTIDO, IZD, CORTO
РЕЗЦЕДЕРЖАТЕЛИ РАДИАЛЬНЫЕ ПЕРЕВЕРНУТЫЕ ЛЕВЫЕ.
КОРОТКОЕ ИСПОЛНЕНИЕ.

PORTAUTENSILE CON SEDE TRASVERSALE
RETTANGOLARE, ROVESCIATO SX CORTO
PORTE-OUTIL RADIAL RENVERSE, GAUCHE, COURT
径向柄, 倒置, LH, 短

DIN 69880 - B4

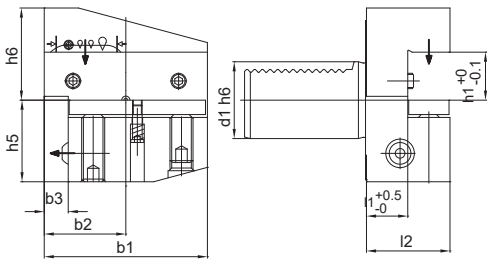

DIN 69880-B4



CODE N.	d1	b1	b2	b3	h1	h5	h6	l1	l2
B4-30x20x40-IC	30	70	35	10	20	35	38	22	40
B4-40x25x44-IC	40	85	42.5	12.5	25	42.5	48	22	44

Spare parts on page 350 - Vedi ricambi a pag. 350 - Ver las piezas de repuesto a la pág. 350
S. Ersatzteile auf Seite 350 - Voyez les pièces détachées à la page 350
Запасные части на стр. 350 - 附件部分见 350 页

RADIAL HOLDER, RH, LONG

RADIAL WERKZEUGHALTER, RECHTS, LANG
PORTAHERRAMIENTAS RADIAL, DCH, LARGO
РЕЗЦЕДЕРЖАТЕЛИ РАДИАЛЬНЫЕ ПРАВЫЕ.
ДЛИННОЕ ИСПОЛНЕНИЕ.

PORTAUTENSILE CON SEDE
TRASVERSALE RETTANGOLARE, DX LUNGO
PORTE-OUTIL RADIAL, DROIT, LONG
径向柄, 倒置, RH, 长

DIN 69880 - B5

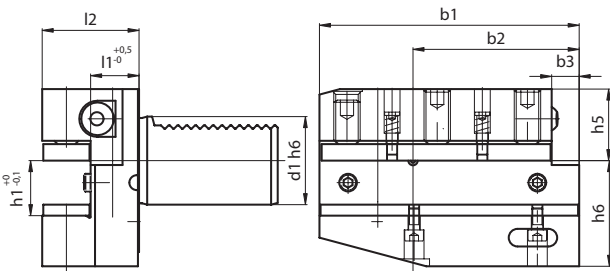

CODE N.	d1	b1	b2	b3	h1	h5	h6	l1	l2
B5-30x20x40	30	100	65	10	20/16	28	38	22	40
B5-40x25x44	40	118	75.5	12.5	25/20	32.5	48	22	44
B5-50x32x55	50	130	80	16	32/25	35	60	30	55
B5-60x32x60	60	145	82.5	16	32/25	42.5	62.5	30	60

Spare parts on page 351 - Vedi ricambi a pag. 351 - Ver las piezas de repuesto a la pág. 351
S. Ersatzteile auf Seite 351 - Voyez les pièces détachées à la page 351
Запасные части на стр. 351 - 附件部分见 349 页

RADIAL HOLDER, LH, LONG

RADIAL WERKZEUGHALTER, LINKS, LANG
PORTAHERRAMIENTAS RADIAL, IZD, LARGO
РЕЗЦЕДЕРЖАТЕЛИ РАДИАЛЬНЫЕ ЛЕВЫЕ.
ДЛИННОЕ ИСПОЛНЕНИЕ.

PORTAUTENSILE CON SEDE
TRASVERSALE RETTANGOLARE, SX LUNGO
PORTE-OUTIL RADIAL, GAUCHE, LONG
径向柄, 倒置, LH, 长

DIN 69880 - B6

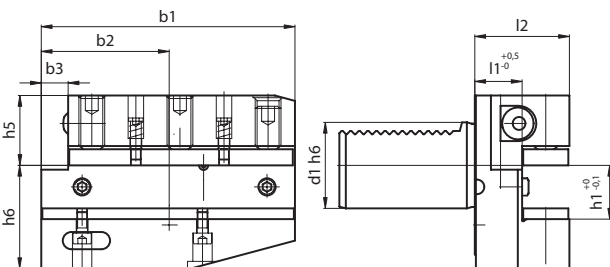

CODE N.	d1	b1	b2	b3	h1	h5	h6	l1	l2
B6-30x20x40	30	100	65	10	20/16	28	38	22	40
B6-40x25x44	40	118	75.5	12.5	25/20	32.5	48	22	44
B6-50x32x55	50	130	80	16	32/25	35	60	30	55
B6-60x32x60	60	145	82.5	16	32/25	42.5	62.5	30	60

Spare parts on page 351 - Vedi ricambi a pag. 351 - Ver las piezas de repuesto a la pág. 351
S. Ersatzteile auf Seite 351 - Voyez les pièces détachées à la page 351
Запасные части на стр. 351 - 附件部分见 349 页

RADIAL HOLDER, UPSIDE-DOWN, RH, LONG

RADIAL WERKZEUGHALTER, ÜBERKOPF RECHTS, LANG
 PORTAHERRAMIENTAS RADIAL, INVERTIDO, DCH, CORTO
 РЕЗЦЕДЕРЖАТЕЛИ РАДИАЛЬНЫЕ ПЕРЕВЕРНУТЫЕ ПРАВЫЕ.
 ДЛИННОЕ ИСПОЛНЕНИЕ.

PORTAUTENSILE CON SEDE TRASVERSALE
 RETTANGOLARE, ROVESCIATO DX LUNGO
 PORTE-OUTIL RADIAL RENVERSE, DROIT, LONG
 径向柄, 倒置, RH, 短

DIN 69880 - B7

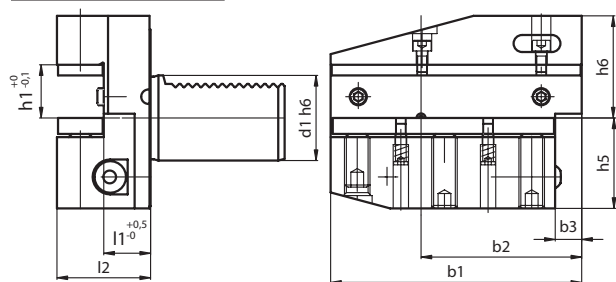

Spare parts on page 351 - Vedi ricambi a pag. 351 - Ver las piezas de repuesto a la pág. 351
 S. Ersatzteile auf Seite 351 - Voyez les pièces détachées à la page 351
 Запасные части на стр. 351 - 附件部分见 349 页

CODE N.	d1	b1	b2	b3	h1	h5	h6	l1	l2
B7-30x20x40	30	100	65	10	20/16	35	38	22	40
B7-40x25x44	40	118	75.5	12.5	25/20	42.5	48	22	44
B7-50x32x55	50	130	80	16	32/25	50	60	30	55
B7-60x32x60	60	145	82.5	16	32/25	62.5	62.5	30	60

RADIAL HOLDER, UPSIDE-DOWN, LH, SHORT

RADIAL WERKZEUGHALTER, ÜBERKOPF LINKS, LANG
 PORTAHERRAMIENTAS RADIAL, INVERTIDO, IZD, LARGO
 РЕЗЦЕДЕРЖАТЕЛИ РАДИАЛЬНЫЕ ПЕРЕВЕРНУТЫЕ ЛЕВЫЕ.
 ДЛИННОЕ ИСПОЛНЕНИЕ.

PORTAUTENSILE CON SEDE TRASVERSALE
 RETTANGOLARE, ROVESCIATO SX LUNGO
 PORTE-OUTIL RADIAL RENVERSE, GAUCHE, LONG
 径向柄, 倒置, LH, 短

DIN 69880 - B8

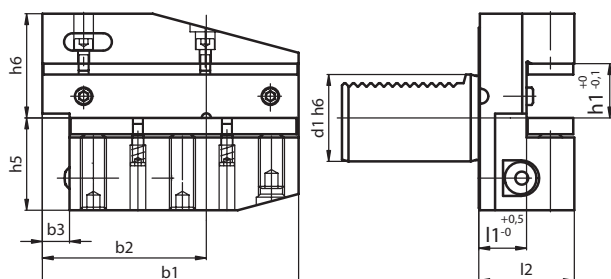

Spare parts on page 351 - Vedi ricambi a pag. 351 - Ver las piezas de repuesto a la pág. 351
 S. Ersatzteile auf Seite 351 - Voyez les pièces détachées à la page 351
 Запасные части на стр. 351 - 附件部分见 349 页

CODE N.	d1	b1	b2	b3	h1	h5	h6	l1	l2
B8-30x20x40	30	100	65	10	20/16	35	38	22	40
B8-40x25x44	40	118	75.5	12.5	25/20	42.5	48	22	44
B8-50x32x55	50	130	80	16	32/25	50	60	30	55

AXIAL HOLDER, RH

AXIAL WERKZEUGHALTER, RECHTS
 PORTAHERRAMIENTAS AXIAL, DCH
 РЕЗЦЕДЕРЖАТЕЛИ
 ОСЕВЫЕ ПРАВЫЕ

PORTAUTENSILE CON SEDE
 LONGITUDINALE RETTANGOLARE, DESTRO
 PORTE-OUTIL AXIAL, DROIT
 轴向刀柄, RH

DIN 69880 - C1

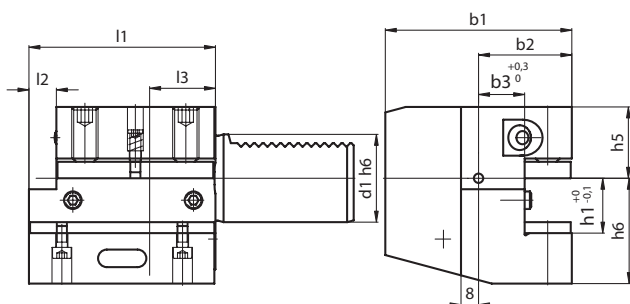

Spare parts on page 352 - Vedi ricambi a pag. 352 - Ver las piezas de repuesto a la pág. 352
 S. Ersatzteile auf Seite 352 - Voyez les pièces détachées à la page 352
 Запасные части на стр. 352 - 附件部分见 352 页

CODE N.	d1	b1	b2	b3	h1	h5	h6	l1	l2	l3
C1-20x16x50	20	65	40	26	16/12	25	30	50	-	30
C1-30x20x70	30	70	35	17	20/16	28	38	70	10	30
C1-40x25x85	40	85	42.5	21	25/20	32.5	48	85	12.5	30
C1-50x32x100	50	100	50	26	32/25	35	60	100	16	40
C1-60x32x125	60	125	62.5	33	32/25	42.5	62.5	125	16	40

AXIAL HOLDER, RH

AXIAL WERKZEUGHALTER, RECHTS PORTAUTENSILE CON SEDE LONGITUDINALE RETTANGOLARE, DESTRO
 PORTAHERRAMIENTAS AXIAL, DCH LONGITUDINALE RETTANGOLARE, DESTRO
 РЕЗЦЕДЕРЖАТЕЛИ ОСЕВЫЕ ПРАВЫЕ PORTE-OUTIL AXIAL, DROIT
 轴向刀柄, RH

DIN 69880 - C1

DIN 69880-C1

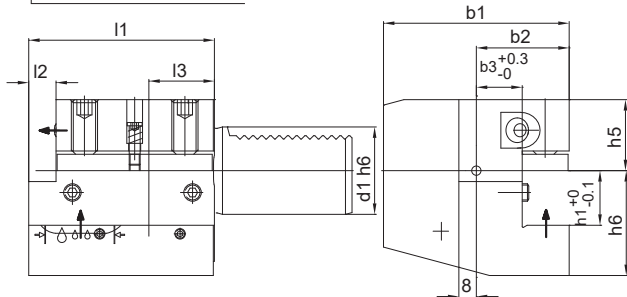

CODE N.	d1	b1	b2	b3	h1	h5	h6	l1	l2	l3
C1-30x20x70-IC	30	70	35	17	20	28	38	70	10	30
C1-40x25x85-IC	40	85	42.5	21	25	32.5	48	85	12.5	30

Spare parts on page 352 - Vedi ricambi a pag. 352 - Ver las piezas de repuesto a la pág. 352
 S. Ersatzteile auf Seite 352 - Voyez les pièces détachées à la page 352
 Запасные части на стр. 352 - 附件部分见 352 页

AXIAL HOLDER, LH

AXIAL WERKZEUGHALTER, LINKS PORTAUTENSILE CON SEDE LONGITUDINALE RETTANGOLARE, SINISTRO
 PORTAHERRAMIENTAS AXIAL, IZD LONGITUDINALE RETTANGOLARE, SINISTRO
 РЕЗЦЕДЕРЖАТЕЛИ ОСЕВЫЕ ЛЕВЫЕ PORTE-OUTIL AXIAL, GAUCHE
 轴向刀柄, LH

DIN 69880 - C2

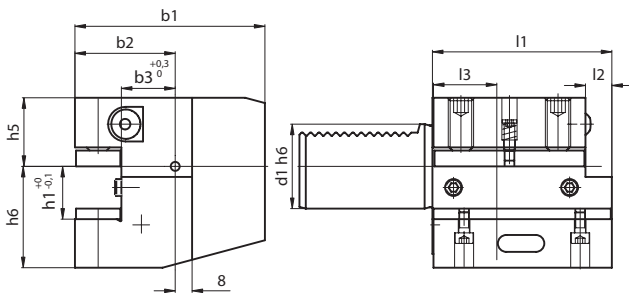

CODE N.	d1	b1	b2	b3	h1	h5	h6	l1	l2	l3
C2-20x16x50	20	65	40	26	16/12	25	30	50	-	30
C2-30x20x70	30	76	41	23	20/16	28	38	70	10	30
C2-40x25x85	40	90	47.5	25.5	25/20	32.5	48	85	12.5	30
C2-50x32x100	50	105	55	30.5	32/25	35	60	100	16	40
C2-60x32x125	60	125	62.5	33	32/25	42.5	62.5	125	16	40

Spare parts on page 352 - Vedi ricambi a pag. 352 - Ver las piezas de repuesto a la pág. 352
 S. Ersatzteile auf Seite 352 - Voyez les pièces détachées à la page 352
 Запасные части на стр. 352 - 附件部分见 352 页

AXIAL HOLDER, LH

AXIAL WERKZEUGHALTER, LINKS PORTAUTENSILE CON SEDE LONGITUDINALE RETTANGOLARE, SINISTRO
 PORTAHERRAMIENTAS AXIAL, IZD LONGITUDINALE RETTANGOLARE, SINISTRO
 РЕЗЦЕДЕРЖАТЕЛИ ОСЕВЫЕ ЛЕВЫЕ PORTE-OUTIL AXIAL, GAUCHE
 轴向刀柄, LH

DIN 69880 - C2

DIN 69880-C2

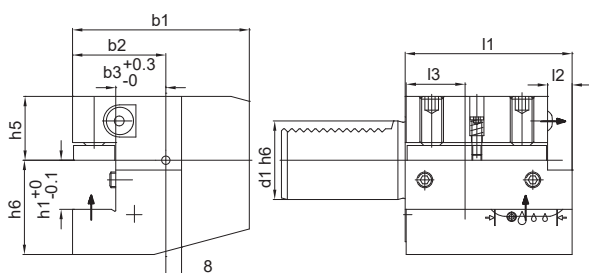

CODE N.	d1	b1	b2	b3	h1	h5	h6	l1	l2	l3
C2-30x20x70-IC	30	76	41	23	20	28	38	70	10	30
C2-40x25x85-IC	40	90	47.5	25.5	25	32.5	48	85	12.5	30

Spare parts on page 352 - Vedi ricambi a pag. 352 - Ver las piezas de repuesto a la pág. 352
 S. Ersatzteile auf Seite 352 - Voyez les pièces détachées à la page 352
 Запасные части на стр. 352 - 附件部分见 352 页

AXIAL HOLDER, UPSIDE-DOWN, RH

AXIAL WERKZEUGHALTER, ÜBERKOPF, RECHTS
PORTAHERRAMIENTAS AXIAL, INVERTIDO, DCH
РЕЗЦЕДЕРЖАТЕЛИ ОСЕВЫЕ
ПЕРЕВЕРНУТЫЕ ПРАВЫЕ.

PORTAUTENSILE CON SEDE
LONGITUDINALE RETTANG. ROVESCiato, DX
PORTE-OUTIL AXIAL, RENVERSE, DROIT
轴向柄, 倒置, RH

DIN 69880 - C3

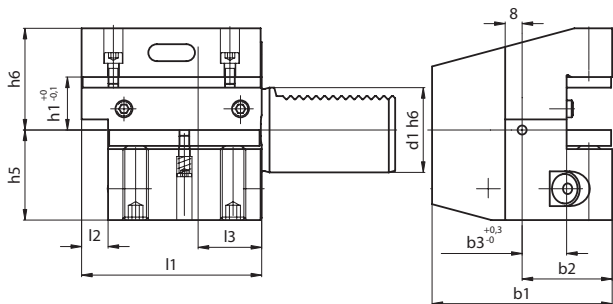

Spare parts on page 352 - Vedi ricambi a pag. 352 - Ver las piezas de repuesto a la pág. 352
S. Ersatzteile auf Seite 352 - Voyez les pièces détachées à la page 352
Запасные части на стр. 352 - 附件部分见 352 页

CODE N.	d1	b1	b2	b3	h1	h5	h6	l1	l2	l3
C3-30x20x70	30	70	35	17	20/16	35	38	70	10	30
C3-40x25x85	40	85	42.5	21	25/20	42.5	48	85	12.5	30
C3-50x32x100	50	100	50	26	32/25	50	60	100	16	40
C3-60x32x125	60	125	62.5	33	32/25	62.5	62.5	125	16	40

AXIAL HOLDER, UPSIDE-DOWN, RH

AXIAL WERKZEUGHALTER, ÜBERKOPF, RECHTS
AXIAL, INVERTIDO, DCH
РЕЗЦЕДЕРЖАТЕЛИ ОСЕВЫЕ
ПЕРЕВЕРНУТЫЕ ПРАВЫЕ.

PORTAUTENSILE CON SEDE
LONGITUDINALE RETTANG. ROVESCiato, DX
PORTE-OUTIL AXIAL, RENVERSE, DROIT
轴向柄, 倒置, RH

DIN 69880 - C3

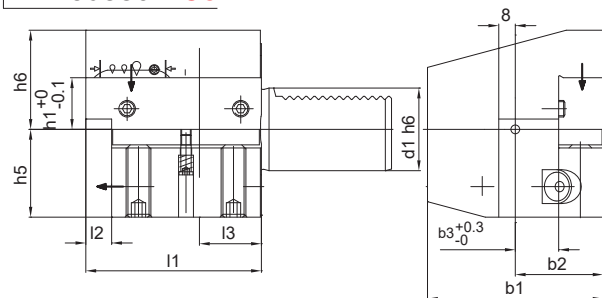

DIN 69880-C3



Spare parts on page 352 - Vedi ricambi a pag. 352 - Ver las piezas de repuesto a la pág. 352
S. Ersatzteile auf Seite 352 - Voyez les pièces détachées à la page 352
Запасные части на стр. 352 - 附件部分见 352 页

CODE N.	d1	b1	b2	b3	h1	h5	h6	l1	l2	l3
C3-30x20x70-IC	30	70	35	17	20	35	38	70	10	30
C3-40x25x85-IC	40	85	42.5	21	25	42.5	48	85	12.5	30

RADIAL WERKZEUGHALTER, ÜBERKOPF, LINKS

AXIAL HOLDER, UPSIDE-DOWN LH
PORTAHERRAMIENTAS RADIAL, INVERTIDO, IZD
РЕЗЦЕДЕРЖАТЕЛИ ОСЕВЫЕ
ПЕРЕВЕРНУТЫЕ ЛЕВЫЕ.

PORTAUTENSILE CON SEDE
LONGITUDINALE RETTANG. ROVESCiato, SX
PORTE-OUTIL AXIAL, RENVERSE, GAUCHE
轴向柄, 倒置, LH

DIN 69880 - C4

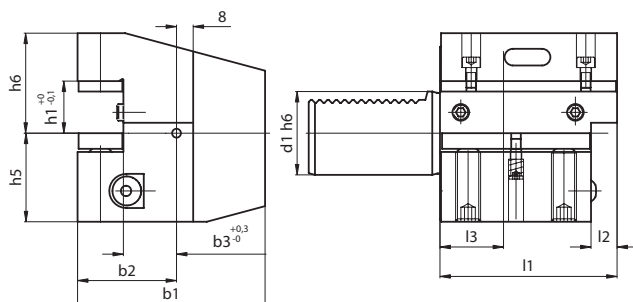

Spare parts on page 352 - Vedi ricambi a pag. 352 - Ver las piezas de repuesto a la pág. 352
S. Ersatzteile auf Seite 352 - Voyez les pièces détachées à la page 352
Запасные части на стр. 352 - 附件部分见 352 页

CODE N.	1	b1	b2	b3	h1	h5	h6	l1	l2	l3
C4-30x20x70	30	76	41	23	20/16	35	38	70	10	30
C4-40x25x85	40	90	47.5	25.5	25/20	42.5	48	85	12.5	30
C4-50x32x100	50	105	55	30.5	32/25	50	60	100	16	40
C4-60x32x125	60	125	62.5	33	32/25	62.5	62.5	125	16	40

AXIAL HOLDER, UPSIDE-DOWN LH

RADIAL WERKZEUGHALTER, ÜBERKOPF, LINKS
PORTAHERRAMIENTAS AXIAL, INVERTIDO, IZD
РЕЗЦЕДЕРЖАТЕЛИ ОСЕВЫЕ
ПЕРЕВЕРНУТЫЕ ЛЕВЫЕ.

PORTAUTENSILE CON SEDE
LONGITUDINALE RETTANG. ROVESCIAIO, SX
PORTE-OUTIL AXIAL, RENVERSE, GAUCHE
轴向柄, 倒置, LH

DIN 69880 - C4

DIN 69880-C4

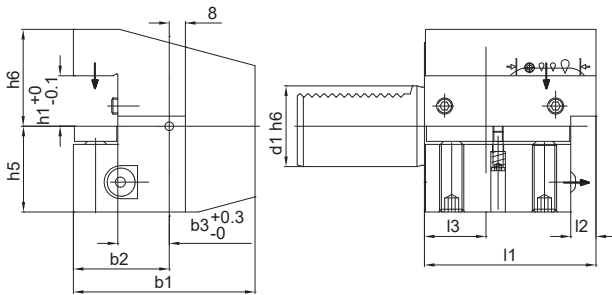

CODE N.	d1	b1	b2	b3	h1	h5	h6	l1	l2	l3
C4-30x20x70-IC	30	76	41	23	20	35	38	70	10	30
C4-40x25x85-IC	40	90	47.5	25.5	25	42.5	48	85	12.5	30

Spare parts on page 352 - Vedi ricambi a pag. 352 - Ver las piezas de repuesto a la pag. 352
S. Ersatzteile auf Seite 352 - Voyez les pièces détachées à la page 352
Запасные части на стр. 352 - 附件部分见 352 页

ACCESSORIES

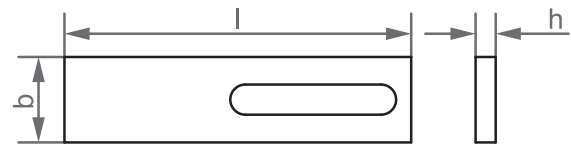
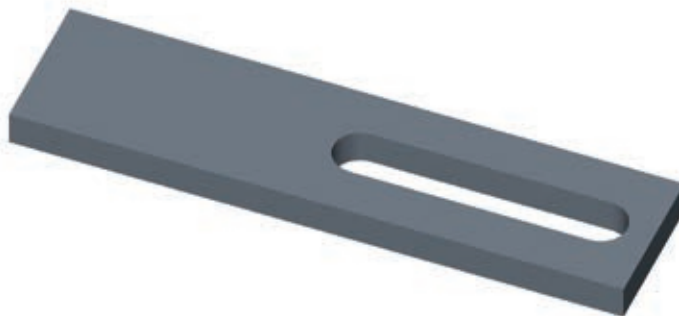

CODE N.	l	b	h	TOOLHOLDER
832-003400	69	17	4	VDI30 B1÷B4-IC, C1÷C4-IC
832-003401	84	21	5	VDI40 B1÷B4-IC, C1÷C4-IC



TOOLHOLDER WITH MULTIPLE SEATS

WERKZEUGHALTER MIT MEHRFACHAUFNAHME
 PORTAUTENSILE A PIU' SEDI RETTANGOLARI
 PORTAHERRAMIENTAS CON VARIOS ASIENTOS
 РЕЗЦЕДЕРЖАТЕЛИ УНИВЕРСАЛЬНЫЕ
 带多个座刀柄

DIN 69880 - D1

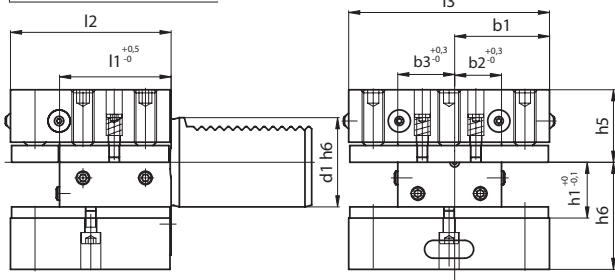

CODE N.	d1	b1	b2	b3	h1	h5	h6	l1	l2	l3
D1-30x20x60	30	35	17	23	20/16	28	38	42	60	76
D1-40x25x72	40	42.5	21	25.5	25/20	32.5	48	50	72	90
D1-50x32x85	50	50	26	30.5	32/25	35	60	60	85	105
D1-60x32x110	60	57.5	33	33	32/25	42.5	62.5	85	110	115

Spare parts on page 353 - Vedi ricambi a pag. 353 - Ver las piezas de repuesto a la pág. 353
 S. Ersatzteile auf Seite 353 - Voyez les pièces détachées à la page 353
 Запасные части на стр. 353 - 附件部分见 353 页



TOOLHOLDER WITH MULTIPLE SEATS UPSIDE DOWN

WERKZEUGHALTER
MIT MEHRFACHAUFNAHME, ÜBERKOPF
PORTAHERRAMIENTAS CON VARIOS ASIENTOS, INVERTIDO
РЕЗЦЕДЕРЖАТЕЛИ УНИВЕРСАЛЬНЫЕ ПЕРЕВЕРНУТЫЕ

PORTAUTENSILE A PIU'
SEDI RETTANGOLARI, ROVESCIATO
PORTE-OUTIL A SIEGES MULTIPLES, RENVERSE
带多个座倒置的刀柄

DIN 69880 - D2

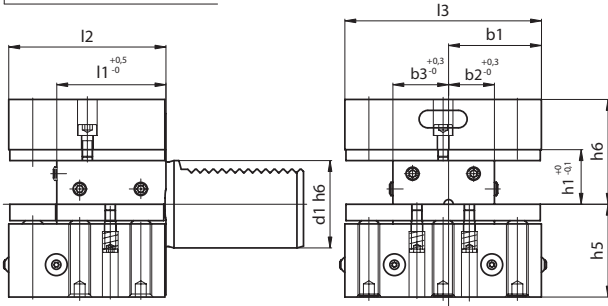

CODE N.	d1	b1	b2	b3	h1	h5	h6	l1	l2	l3
D2-30x20x60	30	35	17	23	20/16	35	38	42	60	76
D2-40x25x72	40	42.5	21	25.5	25/20	42.5	48	50	72	90
D2-50x32x85	50	50	26	30.5	32/25	50	60	60	85	105
D2-60x32x110	60	57.5	33	33	32/25	62.5	62.5	85	110	115

Spare parts on page 353 - Vedi ricambi a pag. 353 - Ver las piezas de repuesto a la pag. 353
S. Ersatzteile auf Seite 353 - Voyez les pièces détachées à la page 353
Запасные части на стр. 353 - 附件部分见 353 页

HOLDER FOR INDEXABLE INSERT DRILLS WITH INTERNAL COOLANT SUPPLY

WERKZEUGHALTER FÜR WENDEPLATTENBOHRER
MIT INNERER KÜHLMITTELZUFUHR
PORTAHERRAMIENTAS PARA BROCAS PARA PLAQUITAS
CON REFRIGERACION INTERNA
ДЕРЖАТЕЛИ ДЛЯ СВЕРЛ С СМП С ВНУТРЕННИМ ПОДВОДОМ СОЖ

PORTAUTENSILE PER PUNTE AD INSERTI
CON PASSAGGIO REFRIGERANTE INTERNO
PORTE-OUTIL POUR FORETS A PLAQUETTES
AVEC ALIMENTATION INTERNE DU LIQUIDE D'ARROSAGE
带内部冷却剂供应的可转位浅孔钻头柄

DIN 69880 - E1

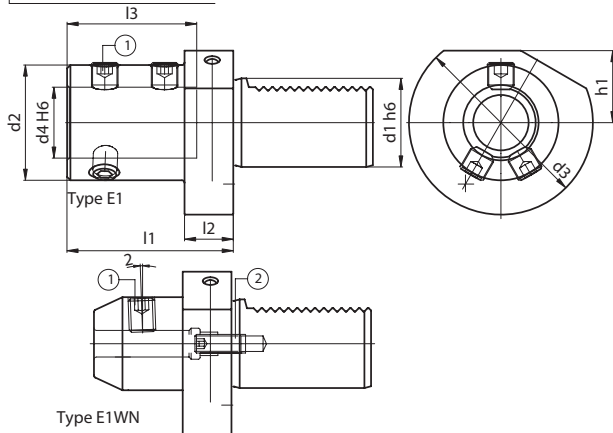

CODE N.	d1	d2	d3	d4	h1	l1	l2	l3	LOCKING SCREW
E1-20x16	20	36	50	16	-	67	18	54	811-402003
E1-20x25	20	45	50	25	-	71	18	58	811-402005
E1-30x08-WN	30	28	68	8	28	50	22	36	811-106002
E1-30x10-WN	30	35	68	10	28	54	22	40	811-106004
E1-30x12-WN	30	42	68	12	28	59	22	45	811-106005
E1-30x16	30	36	68	16	28	67	22	54	811-402003
E1-30x20	30	40	68	20	28	67	22	54	811-402003
E1-30x25	30	45	68	25	28	71	22	58	811-402005
E1-30x32	30	52	68	32	28	75	22	61	811-402005
E1-30x40	30	65	68	40	28	90	22	72	811-402007
E1-40x10-WN	40	35	83	10	32.5	54	22	40	811-106004
E1-40x12-WN	40	42	83	12	32.5	58	22	45	811-106005
E1-40x16	40	36	83	16	32.5	67	22	54	811-402003
E1-40x20	40	40	83	20	32.5	67	22	54	811-402003
E1-40x25	40	45	83	25	32.5	75	22	59	811-402005
E1-40x32	40	52	83	32	32.5	75	22	61	811-402005
E1-40x40	40	65	83	40	32.5	90	22	73	811-402007
E1-40x50	40	70	83	50	32.5	100	22	83	811-402007
E1-50x16	50	36	98	16	35	80	30	54	811-402003
E1-50x20	50	40	98	20	35	80	30	54	811-402003
E1-50x25	50	45	98	25	35	80	30	59	811-402005
E1-50x32	50	52	98	32	35	80	30	63	811-402005
E1-50x40	50	65	98	40	35	90	30	73	811-402007
E1-50x50	50	75	98	50	35	100	30	83	811-402007
E1-60x20	60	40	123	20	42.5	80	30	54	811-402003
E1-60x25	60	45	123	25	42.5	80	30	59	811-402005
E1-60x32	60	52	123	32	42.5	80	30	63	811-402005
E1-60x40	60	65	123	40	42.5	90	30	73	811-402007
E1-60x50	60	75	123	50	42.5	100	30	83	811-402007

WN: Wistle Notch

BORING BAR HOLDER

BOHRSTANGENHALTER PORTAUTENSILE PER BARENI
 PORTAHERRAMIENTAS BARRA BARRAS PORTE-OUTIL POUR BARRES D'ALEPAGE
 ДЕРЖАТЕЛИ ДЛЯ РАСТОЧНЫХ РЕЗЦОВ 搪孔刀杆

DIN 69880 - E2



FORM 1 FORM 2
pag. 362

Accessories
 Accessori
 Zubehör
 Accesorios
 Accessoires
 Принадлежности
 零件

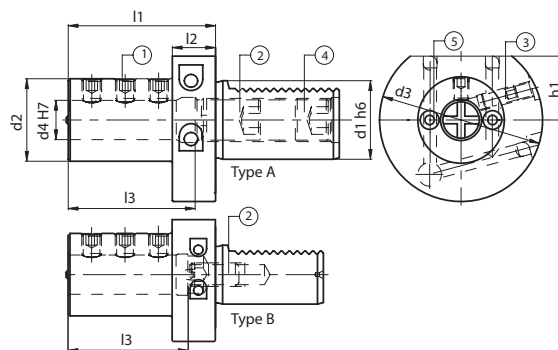

CODE N.	d1	d2	d3	d4	h1	l1	l2	l3	T	LOCKING SCREW	Qt.	STOP SCREW	SCREW	SCREW	COOLANT NOOSE
E2-16x8	16	32	40	8	18	44	13	34	B	811-102020	3	811-102021	811-102011	-	PWZ1005D6X4.5
E2-16x10	16	32	40	10	18	44	13	34	B	811-102020	3	811-102021	811-102011	-	PWZ1005D6X4.5
E2-16x12	16	40	40	12	18	44	13	34	B	811-102028	3	811-402065	811-102011	-	PWZ1005D6X4.5
E2-16x16	16	40	40	16	18	44	13	34	B	811-102028	3	811-402065	811-102011	-	PWZ1005D6X4.5
E2-20x6	20	40	50	6	23	50	18	42	B	811-102021	2	811-102015	-	-	PWZ1008D10X7
E2-20x8	20	40	50	8	23	50	18	42	B	811-102021	2	811-102023	-	-	PWZ1008D10X7
E2-20x10	20	40	50	10	23	50	18	42	B	811-102029	2	811-102023	-	-	PWZ1008D10X7
E2-20x12	20	40	50	12	23	50	18	42	B	811-102029	2	811-402066	-	-	PWZ1008D10X7
E2-20x16	20	42	50	16	23	50	18	42	B	811-102028	2	811-402066	-	-	PWZ1008D10X7
E2-20x20	20	49	50	20	23	50	18	42	B	811-102028	2	811-402066	-	-	PWZ1008D10X7
E2-20x25	20	49	50	25	23	60	18	52	B	811-102027	2	811-402066	-	-	PWZ1008D10X7
E2-30x6	30	55	68	6	28	60	22	43	A	811-102022	3	811-402030	811-102029	811-102070	PWZ1012D12X8
E2-30x8	30	55	68	8	28	60	22	43	A	811-102022	3	811-402030	811-102029	811-102070	PWZ1012D12X8
E2-30x10	30	55	68	10	28	60	22	43	A	811-102022	3	811-402030	811-102029	811-102070	PWZ1012D12X8
E2-30x12	30	55	68	12	28	60	22	43	A	811-102030	3	811-402030	811-102029	811-102070	PWZ1012D12X8
E2-30x16	30	55	68	16	28	60	22	55	A	811-102030	3	811-402071	811-102029	811-402072	PWZ1012D12X8
E2-30x20	30	55	68	20	28	60	22	54	B	811-102029	3	811-402028	811-102029	-	PWZ1012D12X8
E2-30x25	30	55	68	25	28	60	22	54	B	811-102029	3	811-402028	811-102029	-	PWZ1012D12X8
E2-30x32	30	67	68	32	28	75	22	61	B	811-102029	3	811-402029	811-102029	-	PWZ1012D12X8
E2-30x40	30	67	68	40	28	75	22	66	B	811-102029	3	811-402029	811-102019	-	PWZ1008D10X7
E2-40x6	40	55	83	6	32.5	75	22	43	A	811-102022	2	811-402030	811-102029	811-102070	PWZ1012D12X8
E2-40x8	40	55	83	8	32.5	75	22	43	A	811-102030	2	811-402030	811-102029	811-102070	PWZ1012D12X8
E2-40x10	40	55	83	10	32.5	75	22	43	A	811-102030	2	811-402030	811-102029	811-102070	PWZ1012D12X8
E2-40x12	40	55	83	12	32.5	75	22	58	A	811-102030	3	811-402030	811-102029	811-102070	PWZ1012D12X8
E2-40x16	40	55	83	16	32.5	75	22	61	A	811-102038	3	811-402071	811-102029	811-402072	PWZ1012D12X8
E2-40x20	40	55	83	20	32.5	75	22	61	A	811-102037	3	811-402064	811-102029	811-402073	PWZ1012D12X8
E2-40x25	40	55	83	25	32.5	75	22	61	B	811-102038	3	811-402028	811-102029	-	PWZ1012D12X8
E2-40x30	40	82	83	30	32.5	75	22	61	B	811-102037	3	811-402029	811-102029	-	PWZ1012D12X8
E2-40x32	40	82	83	32	32.5	75	22	61	B	811-102038	3	811-402029	811-102029	-	PWZ1012D12X8
E2-40x40	40	82	83	40	32.5	90	22	76	B	811-102037	3	811-402029	811-102029	-	PWZ1012D12X8
E2-40x50	40	98	98	50	35	100	-	86	B	811-102064	3	811-402028	811-102029	-	PWZ1012D12X8
E2-50x12	50	68	98	12	35	90	30	71	A	811-102031	3	811-402030	811-102029	811-102070	PWZ1012D12X8
E2-50x16	50	68	98	16	35	90	30	76	A	811-102039	3	811-402071	811-102029	811-402072	PWZ1012D12X8
E2-50x20	50	68	98	20	35	90	30	76	A	811-102045	3	811-402064	811-102029	811-402073	PWZ1012D12X8
E2-50x25	50	68	98	25	35	90	30	76	A	811-102045	3	811-402074	811-102029	811-402075	PWZ1012D12X8
E2-50x32	50	69	98	32	35	90	30	76	B	811-102044	3	811-402028	811-102029	-	PWZ1012D12X8
E2-50x40	50	98	98	40	35	90	-	76	B	811-102043	3	811-402028	811-102029	-	PWZ1012D12X8
E2-50x50	50	98	98	50	35	100	-	86	B	811-102064	3	811-402028	811-102029	-	PWZ1012D12X8
E2-60x16	60	68	123	16	42.5	90	30	76	A	811-102039	3	811-402071	811-102030	811-402072	PWZ1012D12X8
E2-60x20	60	68	123	20	42.5	90	30	76	A	811-102045	3	811-402064	811-102030	811-402073	PWZ1012D12X8
E2-60x25	60	68	123	25	42.5	90	30	76	A	811-102045	3	811-402074	811-102030	811-402075	PWZ1012D12X8
E2-60x32	60	68	123	32	42.5	90	30	76	A	811-102044	3	811-402076	811-102030	811-402077	PWZ1012D12X8
E2-60x40	60	98	123	40	42.5	90	30	76	B	811-102044	3	811-402029	811-102030	-	PWZ1012D12X8
E2-60x50	60	98	123	50	42.5	100	30	86	B	811-102043	3	811-402029	811-102030	-	PWZ1012D12X8



COLLET CHUCK FOR COLLETS ACCORDING TO DIN 6388, EOC TYPE

SPANNZANGENAUFNAHME FÜR SPANNZANGEN NACH DIN 6388, TYP EOC
 PORTAPINZAS PARA PINZAS DE ACUERDO CON DIN 6388, TIPO OZ
 ЦАНГОВЫЕ ПАТРОНЫ ДЛЯ ЦАНГ ПО DIN 6388, ТИП EOC

PORTAPINZA PER PINZE SECONDO DIN 6388, TIPO EOC
 PORTE-PINCE POUR PINCES SELON DIN 6388, TYPE EOC
 符合 DIN 6388 的 EOC 类弹簧夹头

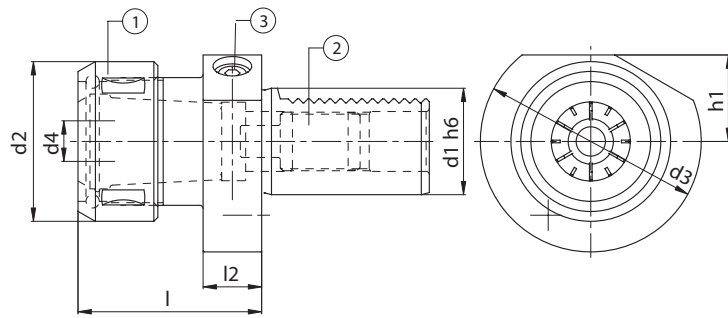
DIN 69880 - E3

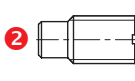

CODE N.	DESCRIPTION	d1	d2	d3	d4	h1	l1	l2	NUT	STOP SCREW	SCREW
E3-30x25	VDI30.L75.EOC25	30	60	68	2-25	28	75	22			
E3-40x25	VDI40.L75.EOC25	40	60	83	2-25	32.5	75	22	812-202070	811-303004	811-302106
E3-40x32	VDI40.L90.EOC32	40	72	83	4-32	32.5	90	22	812-202080	811-303004	811-302106

• Coolant supply unit not included • Adduttore refrigerante non incluso • Tubo de refrigeración no incluido • Kühlmittelrohr nicht inbegriffen • Adducteur réfrigérant non inclus • Поставляется без элементов для подвода СОЖ • 不包括冷却剂供应装置。

BORING BAR HOLDER

BOHRSTANGENHALTER PORTAUTENSILE PER BARENI
 PORTAHERRAMIENTAS PARA BARRAS PORTE-OUTIL POUR BARRES D'ALEPAGE
 ДЕРЖАТЕЛИ ДЛЯ РАСТОЧНЫХ РЕЗЦОВ 搪孔刀杆

DIN 69880 - E2-TAG

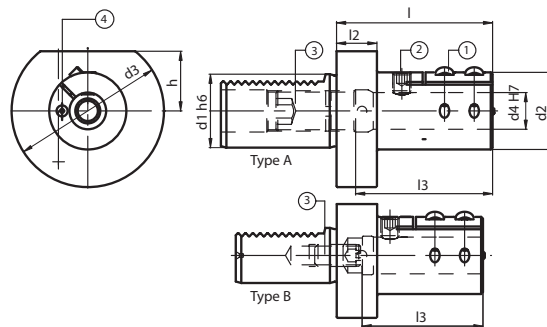

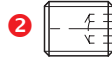
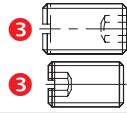
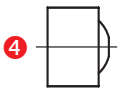
CODE N.	d1	d2	d3	d4	h1	l1	l2	l3	T	LOCKING SCREW	LOCKING SCREW	STOP SCREW	COOLANT NOOSE
E2-30x6-TAG	30	32	68	6	28	75	22	65	A				
E2-30x8-TAG	30	34	68	8	28	75	22	65	A	811-101028	811-102020	811-402030	PWZ1005D6X4.5
E2-30x10-TAG	30	38	68	10	28	75	22	65	A	811-101028	811-102028	811-402030	PWZ1005D6X4.5
E2-30x12-TAG	30	38	68	12	28	75	22	65	A	811-101028	811-102028	811-402030	PWZ1005D6X4.5
E2-30x16-TAG	30	42	68	16	28	75	22	70	A	811-101028	811-102036	811-402071	PWZ1008D8X6
E2-30x20-TAG	30	42	68	20	28	75	22	66	B	811-101028	811-102036	811-402028	PWZ1008D8X6
E2-30x25-TAG	30	48	68	25	28	75	22	66	B	811-101028	811-102036	811-402028	PWZ1008D8X6
E2-30x32-TAG	30	56	68	32	28	75	22	65	B	811-101029	811-102036	811-402028	PWZ1008D10X7
E2-40x6-TAG	40	32	83	6	32,5	75	22	65	A	811-101028	811-102020	811-402030	PWZ1005D6X4.5
E2-40x8-TAG	40	34	83	8	32,5	75	22	65	A	811-101028	811-102020	811-402030	PWZ1005D6X4.5
E2-40x10-TAG	40	38	83	10	32,5	75	22	65	A	811-101028	811-102028	811-402030	PWZ1005D6X4.5
E2-40x12-TAG	40	38	83	12	32,5	75	22	65	A	811-101028	811-102028	811-402030	PWZ1005D6X4.5
E2-40x16-TAG	40	42	83	16	32,5	75	22	68	A	811-101028	811-102036	811-402064	PWZ1008D8X6
E2-40x20-TAG	40	42	83	20	32,5	85	22	80	A	811-101028	811-102036	811-402064	PWZ1008D8X6
E2-40x25-TAG	40	48	83	25	32,5	85	22	76	B	811-101028	811-102036	811-402028	PWZ1008D8X6
E2-40x32-TAG	40	56	83	32	32,5	85	22	76	B	811-101029	811-102036	811-402028	PWZ1008D10X7
E2-40x40-TAG	40	65	83	40	32,5	97	22	90	B	811-101029	811-102069	811-402029	PWZ1008D10X7
E2-50x32-TAG	50	56	98	32	35	98	30	90	B	811-101029	811-102036	811-402029	PWZ1008D10X7
E2-50x40-TAG	50	65	98	40	35	115	30	105	B	811-101029	811-102069	811-402029	PWZ1008D10X7
E2-50x50-TAG	50	76	98	50	35	125	30	112	B	811-101030	811-102069	811-402029	PWZ1008D10X7



BORING BAR HOLDER

TECHNICAL NOTES

DIN 69880 - E2-TAG

- 1) Particularly suitable for vibration-damping- boring bars with HM-shank.
- 2) The particular elastic gripping allows a uniform tool-clamping and reduces vibrations when the tool is working with big projections.
- 3) Fixing occurs by two screws. A third screw, which is perpendicular to the tool, positions the tool itself, resting on the face, on the boring bar shank.
- 4) For completely cylindrical tools there is a reference mark engraved on the front side of the toolholder. It is useful to position the tool.
- 5) There are two kinds of toolholders:
 - a) The VDI- shank is completely drilled. The tool can be positioned through the shank without having to cut it, in case it is too long for machining.
 - b) The VDI- shank is not drilled and has only one adjusting screw at the end of the hole where the tool is placed.
- 6) The VDI- attachment is produced according to the DIN 69880- norms.



PORTAUTENSILE PER BARENI

NOZIONI TECNICHE

DIN 69880 - E2-TAG

- 1) Particolarmente idonei per bareni antivibranti con stelo in metallo duro.
- 2) La particolare chiusura elastica rende uniforme il bloccaggio dell'utensile riducendo notevolmente le vibrazioni quando si lavora con grandi sporgenze.
- 3) Il fissaggio avviene mediante 2 viti, mentre una terza perpendicolare all'utensile inserito serve per l'orientamento dello stesso, appoggiandosi al classico piano di riferimento sullo stelo del bareno.
- 4) In caso di utilizzo di utensili totalmente cilindrici sulla parte frontale del portautensile si trova incisa una riga di riferimento che permette l'orientamento dell'utensile.
- 5) Esistono due tipologie di portautensile:
 - a) Il gambo Vdi e' totalmente forato e permette l'inserimento dell'utensile attraverso lo stesso senza bisogno di un eventuale taglio nel caso si presentasse troppo lungo per le lavorazioni da effettuare.
 - b) Il gambo Vdi non e' forato e presenta solo una vite di registro sul fondo del foro dove viene inserito l'utensile.
- 6) L'attacco Vdi viene costruito seguendo correttamente le prescrizioni date dalle normative Din69880.



BOHRSTANGENHALTER

TECHNISCHE BESONDERHEITEN

DIN 69880 - E2-TAG

- 1) Schwingungsdämpfende Aufnahme. Besonders gut daher geeignet für VHM-Bohrstangen und alle schwingungsdämpfenden Bohrstangen dank der sehr langen Umschließung und tiefer Spannungsmöglichkeit.
- 2) Die besonders lange Vollumschließung der Bohrstange beim Spannen verbunden mit der geschlitzten Ausführung ermöglicht längere Auskraglängen für alle Arten von Bohrstanzen und größere Schnittgeschwindigkeiten ohne Vibrationen oder störende Geräusche.
- 3) Die Befestigung erfolgt durch zwei Schrauben; eine dritte Schraube, die auf der Bohrstange senkrecht steht, dient zur Justierung der Wendeplatte auf Mitte.
- 4) Für zylindrischen Bohrstangen ohne Spannfläche ist vorne am Werkzeughalter eine senkrechte Markierung vorhanden um Bohrstangen mit Längsrille exakt mittig zu spannen.
- 5) Es gibt zwei Typen von Werkzeughaltern:
 - Typ a) Der VDI-Schaft ist aufgebohrt. Die Bohrstange kann in den Schaft eingeführt werden ohne sie zu kürzen.
 - Typ b) Der VDI-Schaft ist nicht aufgebohrt, und hat eine Längeneinstellschraube am Ende der Bohrung.
- 6) Alle VDI-Aufnahmen sind gemaess DIN 69880 gefertigt.



PORTAHERRAMIENTAS PARA BARRAS

DATOS TECNICOS

DIN 69880 - E2-TAG

- 1) Especialmente adecuados para barras anti-vibratorias con mango de metal duro.
- 2) Su particular cierre elástico hace que el bloqueo de la herramienta sea uniforme, reduciendo notablemente las vibraciones cuando se trabaja con grandes proyecciones.
- 3) La fijación se obtiene a través de 2 tornillos, mientras una tercera perpendicular a la herramienta insertada sirve para la orientación de la herramienta misma, apoyándose al plano de referencia sobre el mango de la barra.
- 4) En caso de uso de herramientas totalmente cilíndricas en la parte frontal del portaherramientas se encuentra marcada una línea de referencia que permite la orientación de la herramienta.
- 5) Hay dos tipos de portaherramientas:
 - a. El mango VDI está totalmente perforado y permite que la herramienta sea insertada por el mango mismo, sin necesitar un corte en caso que sea demasiado largo para los mecanizados.
 - b. El mango VDI no está perforado y presenta solo un tornillo en el fondo del agujero donde va insertada la herramienta
- 6) El mango VDI esta fabricado de acuerdo con las normativas DIN69880



PORTE-OUTIL POUR BARRES D'ALEPAGE

RENSEIGNEMENTS TECHNIQUES

DIN 69880 - E2-TAG

- 1) Utilisation préconisée pour les barres d'alesage avec la queue en carbure monobloc.
- 2) La fermeture élastique assure un blocage uniforme de l'outil en réduisant remarquablement les vibrations quand on travaille avec des passes profondes.
- 3) La fixation se fait par vis, une troisième vis perpendiculaire à l'outil sert à l'orientation de celui-ci, en s'appuyant sur la queue de la barre l'alesage.
- 4) Pour les outils cylindrique un repère gravé sert de ligne de référence, ce qui permet l'orientation de l'outil.
- 5) Il y a deux sortes de port-outils:
 - a) La queue Vdi est complètement percée au diamètre de l'outil. L'outil peut alors être utilisé sans être coupé au cas où il soit trop long.
 - b) La queue Vdi n'est pas percée et est placé au fond de l'alesage destiné à l'outil.
- 6) Dans les deux cas l'attachement Vdi est fabriqué selon les normes Din69880.



ДЕРЖАТЕЛИ ДЛЯ РАСТОЧНЫХ РЕЗЦОВ

ТЕХНИЧЕСКИЕ ХАРАКТЕРИСТИКИ

DIN 69880 - E2-TAG

- 1) Лучше всего подходят для виброгасящих державок из твердого сплава.
- 2) Специальное гибкое крепление обеспечивает равномерный зажим и уменьшает вибрации при работе инструмента с большим вылетом.
- 3) Крепление осуществляется при помощи двух винтов. Третий винт, расположенный перпендикулярно державке, упирается в плоскость ее хвостовика и тем самым позиционирует инструмент.
- 4) На торце резцедержателя находится риска. Она необходима, чтобы установить режущий инструмент с гладким цилиндрическим хвостовиком.
- 5) Существует два типа резцедержателей:
 - a) С хвостовиком VDI с внутренним каналом для СОЖ. Вылет режущего инструмента можно регулировать по всей длине резцедержателя. Тем самым отпадает необходимость укорачивать слишком длинный инструмент.
 - b) С хвостовиком VDI без внутреннего канала для СОЖ. Регулировка вылета инструмента осуществляется одним винтом в конце отверстия под инструмент.
- 6) Хвостовики VDI производятся согласно стандарту DIN 69880.



搪孔刀杆

技术要点

DIN 69880 - E2-TAG

- 1) 尤其适用于防震带 HM 柄的搪孔。
- 2) 专用弹性夹紧可在工具有大的伸出量时, 实现均匀的工具夹紧, 同时减少震动。
- 3) 用两个螺丝固定。第三个螺丝与工具垂直, 可使工具在搪孔柄上面的表面上定好位。
- 4) 对于完全圆柱形的工具, 在刀柄的正面有一个雕刻的参考标志。这个标志对于工具的定位很有用。
- 5) 有两种刀柄。
 - a) VDI 柄是完全被钻透。如果工具太长无法进行机械加工, 则工具可以在不被切割的条件下, 通过柄就位。
 - b) VDI 柄未被钻透, 只在孔的末端有一个可调螺丝, 通过这个螺丝来安放工具。
- 6) VDI 附件的生产符合 DIN 69880 - 标准。

COLLET CHUCK FOR COLLETS ACCORDING TO DIN 6499/B, ER TYPE

SPANNZANGENAUFNAHME FÜR SPANNZANGEN NACH DIN 6499/B, TYP ER PORTAPINZA PER PINZE SECONDO DIN 6499/B, TIPO ER
 PORTAPINZAS PARA PINZAS DE ACUERDO CON DIN 6499/B, TIPO ER PORTE-PINZ POUR PINCES SELON DIN 6499/B, TYPE ER
 ЦАНГОВЫЕ ПАТРОНЫ ДЛЯ ЦАНГ ПО DIN 6499/B, ТИП ER 符合 DIN 6499 的 ER 弹簧夹头

DIN 69880 - E4

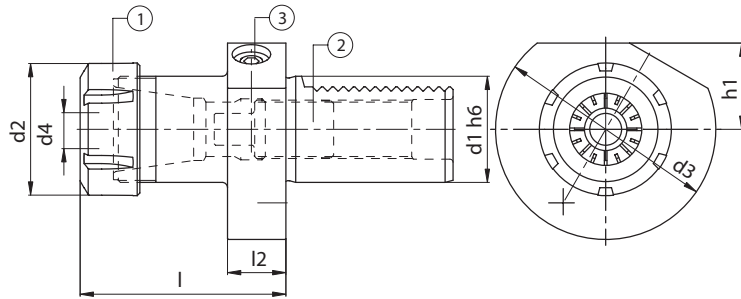

CODE N.	DESCRIPTION	d1	d2	d3	d4	h1	l1	l2	NUT	STOP SCREW	SCREW
E4-16x20	VDI16.L44.ER20	16	35	40	1-13	18	44	13	812-203006	811-104015	811-302011
E4-20x16	VDI20.L44.ER16	20	32	50	1-10	-	44	18	812-203005	811-104022	811-302011
E4-20x20	VDI20.L59.ER20	20	35	50	1-13	-	59	18	812-203006	811-303001	811-302106
E4-20x25	VDI20.L65.ER25	20	42	50	2-16	-	65	18	812-203001	811-303001	811-302106
E4-20x32	VDI20.L67.ER32	20	50	50	2-20	-	67	18	812-203002	811-303001	811-302106
E4-30x16	VDI30.L48.ER16	30	32	68	1-10	28	48	22	812-203005	811-303001	811-302106
E4-30x20	VDI30.L59.ER20	30	35	68	1-13	28	59	22	812-203006	811-303014	811-302106
E4-30x25	VDI30.L57.ER25	30	42	68	2-16	28	57	22	812-203001	811-303014	811-302106
E4-30x32	VDI30.L78.ER32	30	50	68	2-20	28	78	22	812-203002	811-303014	811-302106
E4-30x40	VDI30.L80.ER40	30	63	68	3-30	28	80	22	812-203003	811-303014	811-302106
E4-40x20	VDI40.L59.ER20	40	35	83	1-13	32.5	59	22	812-203006	811-303003	811-302106
E4-40x25	VDI40.L57.ER25	40	42	83	2-16	32.5	57	22	812-203001	811-303003	811-302106
E4-40x32	VDI40.L78.ER32	40	50	83	2-20	32.5	78	22	812-203002	811-303004	811-302106
E4-40x40	VDI40.L80.ER40	40	63	83	3-30	32.5	80	22	812-203003	811-303004	811-302106
E4-50x32	VDI50.L92.ER32	50	50	98	2-20	35	92	30	812-203002	811-303004	811-302106
E4-50x40	VDI50.L80.ER40	50	63	98	3-30	35	80	30	812-203003	811-303004	811-302106
E4-60x32	VDI60.L78.ER32	60	50	123	2-20	42.5	78	30	812-203002	811-303004	811-302106
E4-60x40	VDI60.L80.ER40	60	63	123	3-30	42.5	80	30	812-203003	811-303004	811-302106

• Coolant supply unit not included • Adduttore refrigerante non incluso • Tubo de refrigeración no incluido • Kühlmittelrohr nicht inbegriffen
 • Adducteur réfrigérant non inclus • Поставляется без элементов для подвода СОЖ • 不包括冷却剂供应装置。

DOUBLE BORING BAR HOLDER, RIGHT

WERKZEUGHALTER MIT ZWEI BOHRUNGEN RECHTS PORTABARENO DOPPIO DESTRO
 PORTABARRAS DOBLE, DERECHO PORTE-OUTIL DOUBLE DROIT
 ДВОЙНЫЕ ДЕРЖАТЕЛИ ДЛЯ РАСТОЧНЫХ РЕЗЦОВ ПРАВЫЕ 右侧双搪孔刀柄

DIN 69880 - E7



Accessories
 Accessori
 Zubehör
 Accesorios
 Accessoires
 Принадлежности
 零件
 pag. 362

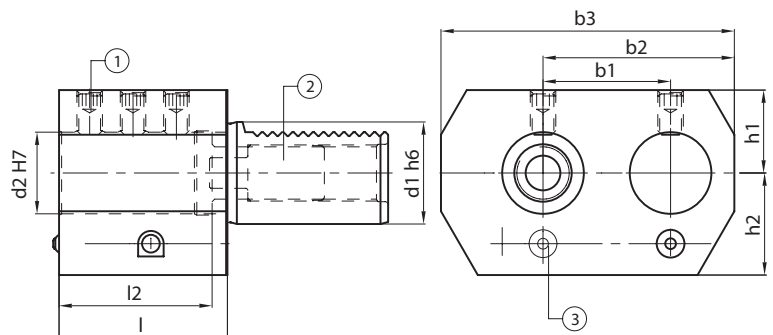

CODE N.	d1	d2	h1	h2	l1	l2	b1	b2	B3	LOCKING SCREW	Qt.	STOP SCREW	COOLANT NOOSE
E7-30x25	30	25	28	32	56	52	45	65	95	811-102029	6	811-303003	PWZ1008D10x7
E7-40x32	40	32	32.5	40	66	60	50	75	115	811-102037	6	811-303004	PWZ1008D10x7
E7-50x32	50	32	32.5	47.5	66	60	50	75	115	811-102037	6	811-303004	PWZ1008D10x7
E7-50x50	50	50	35	49	90	80	68	103	152	811-102064	6	811-303005	PWZ1012D12x8

DOUBLE BORING BAR HOLDER, LEFT

WERKZEUGHALTER MIT ZWEI BOHRUNGEN LINKS

PORTABARENO DOPPIO SINISTRO

PORTABARRAS DOBLE, IZQUIERDO

PORTE-OUTIL DOUBLE GAUCHE



ДВОЙНЫЕ ДЕРЖАТЕЛИ ДЛЯ РАСТОЧНЫХ РЕЗЦОВ ЛЕВЫЕ

左侧双搪孔刀柄

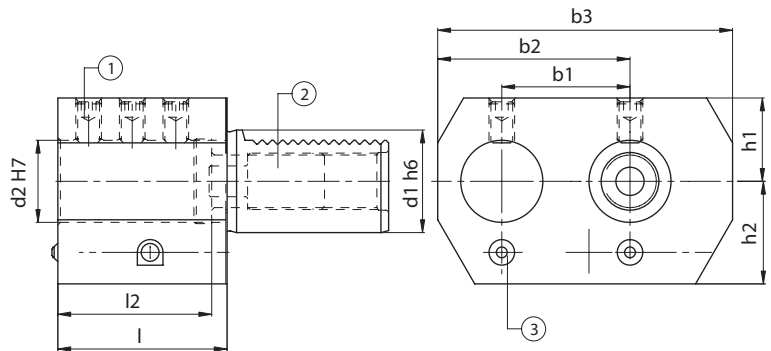
DIN 69880 - E8

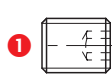
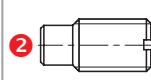

Accessories
Accessori
Zubehör
Accesorios
Accessoires
Принадлежности
零件

CODE N.	d1	d2	h1	h2	l1	l2	b1	b2	b3	LOCKING SCREW	Qt.	STOP SCREW	COOLANT NOOSE
													
E8-30x25	30	25	28	32	56	52	45	65	95	811-102029	6	811-303003	PWZ1008D10x7
E8-40x32	40	32	32.5	40	66	60	50	75	115	811-102037	6	811-303004	PWZ1008D10x7
E8-50x32	50	32	32.5	47,5	66	60	50	75	115	811-102037	6	811-303004	PWZ1008D10x7
E8-50x50	50	50	35	49	90	80	68	103	152	811-102064	6	811-303005	PWZ1012D12x8

MORSE TAPER HOLDER

MORSEKEGEL-AUFNAHME

PORTAUTENSILE CON SEDE CONO MORSE

PORTAHERRAMIENTAS PARA CONO MORSE

PORTE-OUTIL POUR CONE MORSE

ДЕРЖАТЕЛИ ДЛЯ ИНСТРУМЕНТА С КОНУСОМ МОРСЕ

莫氏锥度柄

DIN 69880 - F

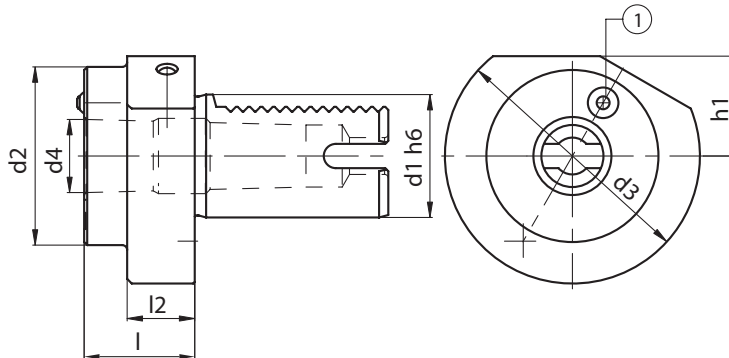

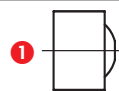
CODE N.	d1	d2	d3	MK	d4	h1	l1	l2	COOLANT NOOSE
									
F30-MKD1	30	-	68	1	12.065	28	27	-	PWZ1008D10X7
F30-MKD2	30	55	68	2	17.780	28	36	27	PWZ1008D10X7
F30-MKD3	30	55	68	3	23.825	28	66	41	PWZ1008D10X7
F40-MKD1	40	55	83	1	12.065	32.5	23	22	PWZ1008D10X7
F40-MKD2	40	55	83	2	17.780	32.5	36	22	PWZ1008D10X7
F40-MKD3	40	58	83	3	23.825	32.5	36	22	PWZ1008D10X7
F40-MKD4	40	68	83	4	31.267	32.5	80	22	PWZ1008D10X7
F50-MKD2	50	55	98	2	17.780	35	36	30	PWZ1008D10X7
F50-MKD3	50	58	98	3	23.825	35	45	30	PWZ1008D10X7
F50-MKD4	50	68	98	4	31.267	35	55	30	PWZ1008D10X7
F50-MKD5	50	75	98	5	44.399	35	72	30	PWZ1008D10X7

• Without VDI shank! • Senza dentatura VDI! • Sin dentado VDI! • Ohne Verzahnung!
Sans denture VDI! • Без хвостовика VDI! • 无 VDI 柄

ROTARY ADJUSTABLE BAR-STOP

WERKSTOFFANSCHLAG, VESTELLBAR FERMOBARRA ROTANTI REGOLABILI
 PARADORES DE BARRA ROTATORIOS, AJUSTABLES PORTE-OUTIL VDI À BUTÉE RÉGLABLE
 УПОРЫ РЕГУЛИРУЕМЫЕ 旋转式可调制动杆

DIN 69880 - MW

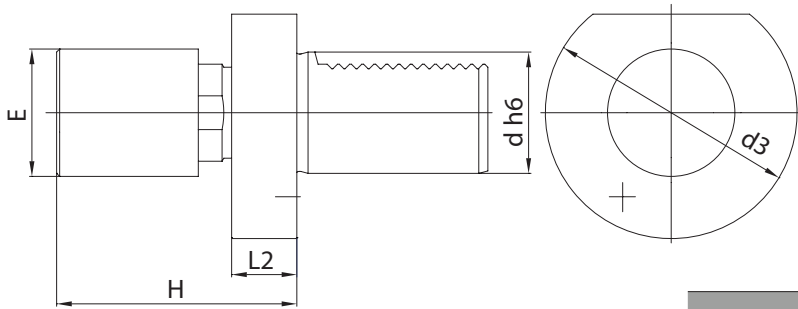

CODE N.	d	H	d3	L2	E
MW3042	30	68-100	68	16	42
MW4042	40	74-100	83	22	42

DAMPED, ADJUSTABLE, STOP BAR

WERKSTOFFANSCHLAG, VESTELLBAR, GEDÄMPFT FERMOBARRA ROTANTI REGOLABILI AMMORTIZZATI
 PARADORES DE BARRA ROTATORIOS, AJUSTABLES, AMORTIZADOS PORTE-OUTIL VDI À BUTÉE RÉGLABLE, AMORTIE
 УПОРЫ РЕГУЛИРУЕМЫЕ С АМОРТИЗАЦИЕЙ 阻尼可调制动杆

DIN 69880 - MW-AM

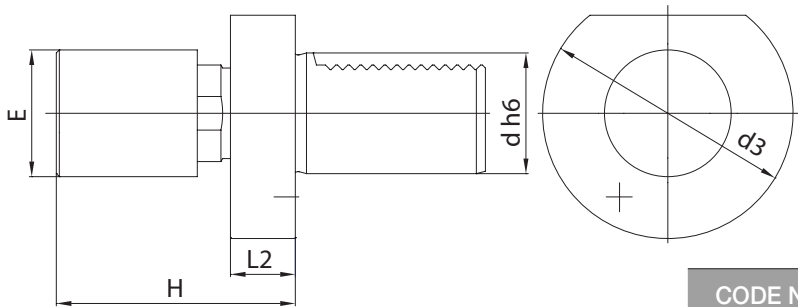

CODE N.	d	H	d3	L2	E
MW-3042-AM	30	68-100	68	16	42
MW-3056-AM	30	68-100	68	16	56
MW-4042-AM	40	74-100	83	22	42



ADAPTORS FOR DRILLS WITH INTERNAL COOLANT SUPPLY

ZWISCHENHÜLSEN MIT ZENTRALEM KÜHLMITTELLOCH MANDRINO PORTAPUNTE CON PASS. REFRIGERANTE CENTRALE
 PORTABROCAS CON REFRIGERACION CENTRAL DOUILLES AVEC ARROSAGE INTERNE

СВЕРЛИЛЬНЫЕ ПАТРОНЫ С ВНУТРЕННИМ ПОДВОДОМ СОЖ 内部带冷却装置的钻头接头

DIN 69880 - KS1

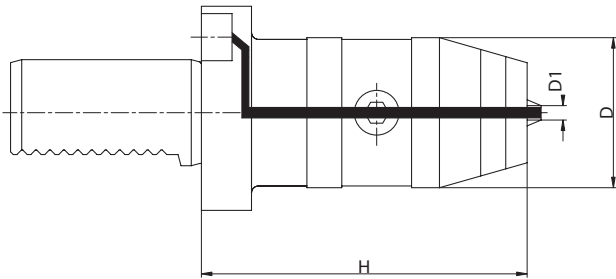

CODE N.	DESCRIPTION	H	D	CLAMPING CAPACITY
KS1-30-13	VDI30x55 0,5-13	90	50	0,5-13
KS1-30-16	VDI30x55 2,5-16	90	50	2,5-16
KS1-40-13	VDI40x63 0,5-13	90	50	0,5-13
KS1-40-16	VDI40x63 2,5-16	90	50	2,5-16

ADAPTORS FOR DRILLS WITH LATERAL COOLANT SUPPLY

ZWISCHENHÜLSEN MIT SEITLICHEM KÜHLMITTELLOCH MANDRINO PORTAPUNTE CON PASS. REFRIGERANTE LATERALE
 PORTABROCAS CON REFRIGERACION LATERAL DOUILLES AVEC ARROSAGE LATERALE

СВЕРЛИЛЬНЫЕ ПАТРОНЫ С БОКОВЫМ ПОДВОДОМ СОЖ 侧面带冷却装置的钻头接头

DIN 69880 - KS2

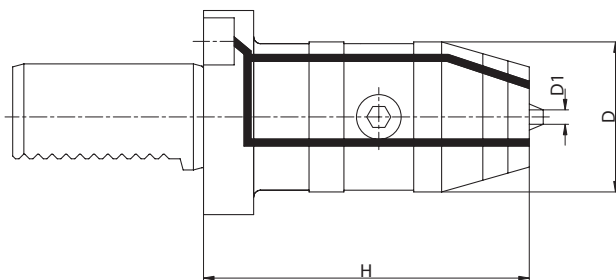

CODE N.	DESCRIPTION	H	D	CLAMPING CAPACITY
KS2-30-16	VDI30x55 2,5-16	82	57	2,5-16
KS2-40-13	VDI40x63 0,5-13	85	57	0,5-13
KS2-40-16	VDI40x63 2,5-16	85	57	2,5-16

BAR PULLER

STANGENGREIFER STRINGIBARRA
 EXTRACTOR DE BARRAS SERRE BARRE
 ДЕРЖАТЕЛИ ПРУТКА 搪孔抽动器

DIN 69880 - HK1

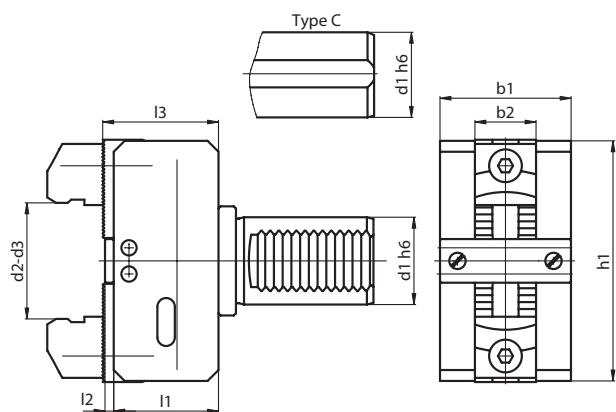

CODE N.	d1	d2 (short)	d3 (long)	b1	b2	h1	l1	l2	l3
H120K	20	6-56	-	50	28	72	46	4	51
H125K	25	6-56	54-110	50	28	72	46	4	51
H125KC	25	6-56	54-110	50	28	72	46	4	51
H130K	30	6-56	54-110	50	28	72	46	4	51
H132KC	32	6-56	54-110	50	28	72	46	4	51
H140K	40	6-66	54-110	60	28	110	48	4	53
H140KC	40	6-66	54-110	60	28	110	48	4	53
H150K	50	10-75	62-125	65	28	130	67	5	73
H150KC	50	10-75	62-125	65	28	130	67	5	73
H160K	60	10-75	62-125	65	28	130	67	5	73

Spare parts on page 354 - Vedi ricambi a pag. 354 - Ver las piezas de repuesto a la pág. 354
 S. Ersatzteile auf Seite 354 - Voyez les pièces détachées à la page 354
 Запасные части на стр. 354 - 附件部分见 354 页

OPERATING MANUAL FOR BAR PULLER

GEBRAUCHSANWEISUNG FÜR DEN STANGENGREIFER
 MANUAL DE INSTRUCCIONES PARA LOS EXTRACTORES DE BARRAS
 ИНСТРУКЦИЯ ПО ЭКСПЛУАТАЦИИ ДЕРЖАТЕЛЯ ПРУТКА

MANUALE DI UTILIZZO PER GLI STRINGIBARRA
 NOTICE D'UTILISATION DU SERRE BARRE
 搪孔抽动器的操作手册。

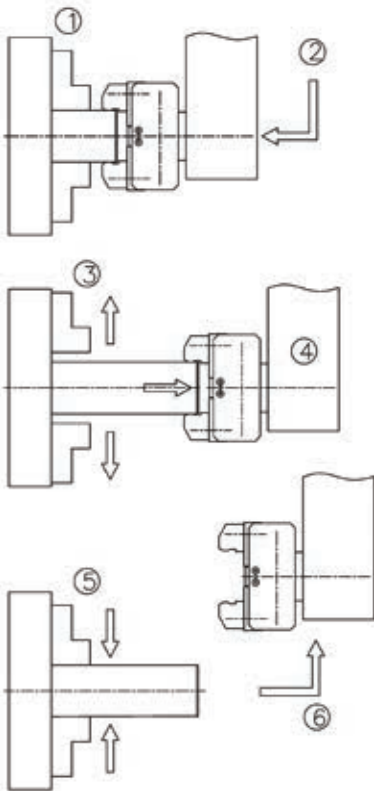

- 1) Il mandrino autocentrante si ferma.
 The self-centering chuck stops.
 El plato se para.
 La broche et son mandrin à centrage automatique s'arrêtent.
 Das selbstzentrierende Backenfutter bleibt geschlossen.
 Остановка самоцентрирующегося патрона
 自定心夹头制动。
- 2) Dopo aver regolato le griffe di chiusura di 3-5mm in meno del diametro della barra da tirare, andare a prendere il pezzo.
 After positioning the jaws 3-5mm less than the measure of the bar diameter, clamp the bar.
 Après avoir réglé les griffes de fermeture de 3-5mm inférieur au diamètre de la barre à tirer, princer la barre.
 Colocar las garras de 3-5mm por debajo del Ø de la barra. Aproximar el extractor hasta coger la barra.
 Nachdem die Spannbacken des Stangengreifers um 3-5mm kleiner als der Durchmesser der zu greifenden Stange eingestellt worden sind, das Stück greifen.
 Захват прутка держателем. Расстояние между губками держателя должно быть на 3-5 мм меньше, чем диаметр заготовки.
 将狭口放在低于杆的直径 3-5 毫米外定位后, 将杆夹紧。
- 3) L'autocentrante si apre.
 The self-centering chuck opens.
 Abrir las garras de apriete del plato.
 Le mandrin à centrage automatique s'ouvre.
 Das selbstzentrierende Backenfutter öffnet sich.
 Раскрытие самоцентрирующегося патрона
 自定心夹头启动。
- 4) Lo stringibarra tira il pezzo/barra.
 The bar puller pulls the bar.
 Extraer la barra hasta la medida deseada.
 Le serre-barre tire la barre.
 Der Stangengreifer zieht das Stück/die Stange auf die gewünschte Länge.
 Вытягивание заготовки держателем прутка
 搪孔抽动器将杆抽动。
- 5) L'autocentrante blocca il pezzo.
 The self-centering chuck clamps the bar.
 Cerrar las garras del plato.
 Le mandrin à centrage automatique se referme sur la barre.
 Das selbstzentrierende Backenfutter wird geschlossen.
 Зажим заготовки самоцентрирующимся патроном
 自定心夹头将杆夹紧。
- 6) Lo stringibarra lascia/molla il pezzo.
 The bar puller releases the bar.
 El extractor de barra libera la barra.
 Le serre-barre relache la barre.
 Der Stangengreifer geht zurück und die Backen öffnen sich selbständig.
 Отсоединение держателя от прутка
 搪孔抽动器将杆放开。
- 7) Continua la lavorazione.
 The work goes on.
 El trabajo puede continuar.
 Le cycle d'usinage peut alors continuer.
 Die Bearbeitung geht weiter.
 Продолжение обработки
 工作继续进行。

11



TENSION AND COMPRESSION TAPPING HEAD

GEWINDESCHNEID-SCHNELLWECSSELFUTTER
 MIT LÄNGENAUSGLEICH
 ROSCADORES DE DOBLE COMPENSACION
 РЕЗЬБОНАРЕЗНЫЕ ПАТРОНЫ С КОМПЕНСАЦИЕЙ

MASCHIATORI A DOPPIA COMPENSAZIONE
 MANDRINS DE TARAUDAGE A CHANGEMENT
 RAPIDE A DOUBLE USAGE
 张力和压缩丝攻头

DIN 69880 - M

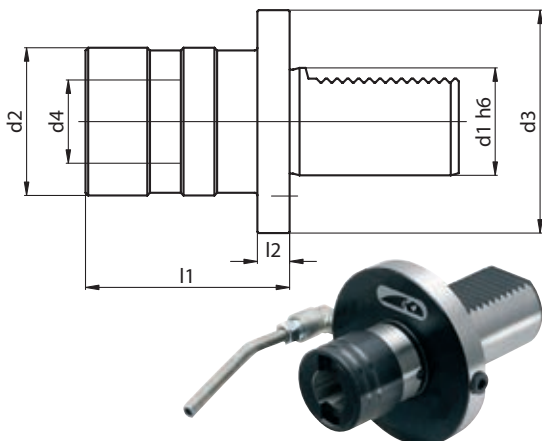

CODE N.	d1	TOP RANGE	Size	Ext.	Pres.	d2	d3	d4	l1	l2
M2710	20	M3-M12	1	9	9	38	50	19	55	12
M2720	30	M3-M12	1	9	9	38	68	19	55	12
M2730	40	M3-M12	1	9	9	38	83	19	55	12
M2820	30	M6-M20	2	15	15	55	68	31	77	12
M2830	40	M6-M20	2	15	15	55	83	31	77	12
M2930	40	M14-M33	3	24	24	79	83	48	110	12
M2940	50	M14-M33	3	24	24	79	98	48	110	12

Accessories
 Accessori
 Zubehör
 Accesorios
 Accessoires
 Принадлежности
 零件



TOOLHOLDER FOR CUT OFF TOOLS ADJUSTABLE IN HEIGHT, RIGHT

ABSTECHMEISSELHALTER, HÖHENEINSTELLBAR, RECHTS
PORTAHERRAMIENTAS AJUSTABLE CON ASIENTO
PARA CUCHILLA DE CORTE, DERECHO
ДЕРЖАТЕЛИ ОТРЕЗНЫХ РЕЗЦОВ С
ВЕРТИКАЛЬНОЙ РЕГУЛИРОВКОЙ ПРАВЫЕ

PORTAUTENSILE REGOLABILE
CON SEDE PER LAMA DA TAGLIO, DESTRO
PORTE-OUTIL DE TRONCONNAGE
AVEC REGLAGE EN HAUTEUR, A DROITE
用于切割工具的刀柄高度可调, 右侧

DIN 69880 - AR

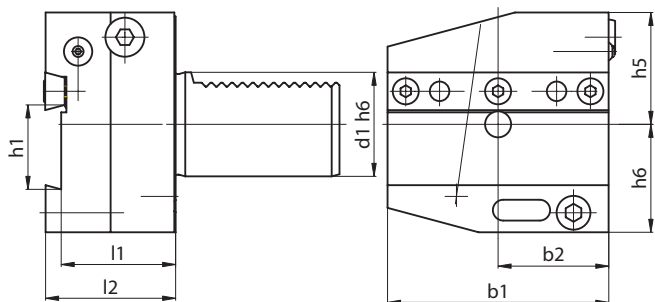

Spare parts on page 355 - Vedi ricambi a pag. 355 - Ver las piezas de repuesto a la pág. 355
S. Ersatzteile auf Seite 355 - Voyez les pièces détachées à la page 355
Запасные части на стр. 355 - 附件部分见 355 页

CODE N.	d1	b1	b2	h1	h5	h6	l1	l2
AR3026	30	70	35	26	32	39	44	50
AR4026	40	85	42.5	26	43	41.5	44	50
AR4032	40	85	42.5	32	43	41.5	44	50
AR5026	50	100	50	26	43	45	44	50
AR5032	50	100	50	32	43	45	44	50

TOOLHOLDER FOR CUT OFF TOOLS ADJUSTABLE IN HEIGHT, RIGHT

ABSTECHMEISSELHALTER, HÖHENEINSTELLBAR, RECHTS
PORTAHERRAMIENTAS AJUSTABLE CON ASIENTO
PARA CUCHILLA DE CORTE, DERECHO
ДЕРЖАТЕЛИ ОТРЕЗНЫХ РЕЗЦОВ С
ВЕРТИКАЛЬНОЙ РЕГУЛИРОВКОЙ ПРАВЫЕ

PORTAUTENSILE REGOLABILE
CON SEDE PER LAMA DA TAGLIO, DESTRO
PORTE-OUTIL DE TRONCONNAGE
AVEC REGLAGE EN HAUTEUR, A DROITE
用于切割工具的刀柄高度可调, 右侧

DIN 69880 - AR

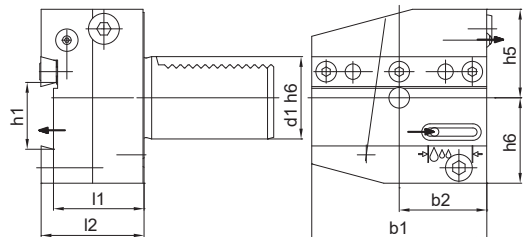

DIN 69880-AR



Spare parts on page 355 - Vedi ricambi a pag. 355 - Ver las piezas de repuesto a la pág. 355
S. Ersatzteile auf Seite 355 - Voyez les pièces détachées à la page 355
Запасные части на стр. 355 - 附件部分见 355 页

CODE N.	d1	b1	b2	h1	h5	h6	l1	l2
AR3026-IC	30	70	35	26	32	39	44	50
AR4026-IC	40	85	42.5	26	43	41.5	44	50
AR4032-IC	40	85	42.5	32	43	41.5	44	50

TOOLHOLDER FOR CUT OFF TOOLS ADJUSTABLE IN HEIGHT, UPSIDE-DOWN, LEFT

ABSTECHMEISSELHALTER,
HÖHENEINSTELLBAR, ÜBERKOPF LINKS
PORTAHERRAMIENTAS AJUSTABLE CON ASIENTO
PARA CUCHILLA DE CORTE, INVERTIDO, IZQUIERDO
ДЕРЖАТЕЛИ ОТРЕЗНЫХ РЕЗЦОВ С ВЕРТИКАЛЬНОЙ
РЕГУЛИРОВКОЙ ПЕРЕВЕРНУТЫЕ ЛЕВЫЕ

PORTAUTENSILE REGOLABILE CON SEDE
PER LAMA DA TAGLIO ROVESCiato, SINISTRO
PORTE-OUTIL DE TRONCONNAGE
AVEC REGLAGE EN HAUTEUR, RENVERSE, GOUCHE
用于切割工具的刀柄高度可调, 倒置, 右侧(左侧)

DIN 69880 - ALU

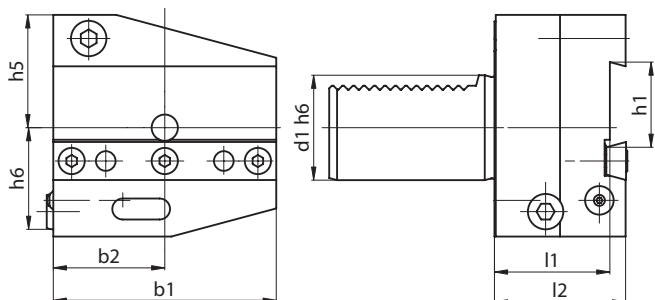

Spare parts on page 355 - Vedi ricambi a pag. 355 - Ver las piezas de repuesto a la pág. 355
S. Ersatzteile auf Seite 355 - Voyez les pièces détachées à la page 355
Запасные части на стр. 355 - 附件部分见 355 页

CODE N.	d1	b1	b2	h1	h5	h6	l1	l2
ALU3026	30	70	35	26	38	35	44	50
ALU4032	40	85	42.5	32	43	41.5	44	50

TOOLHOLDER FOR CUT OFF TOOLS ADJUSTABLE IN HEIGHT, LEFT

ABSTECHEMISSELHALTER, HÖHENEINSTELLBAR, LINKS
 PORTAHERRAMIENTAS AJUSTABLE CON ASIENTO
 PARA CUCHILLA DE CORTE, IZQUIERDO
 ДЕРЖАТЕЛИ ОТРЕЗНЫХ РЕЗЦОВ
 С ВЕРТИКАЛЬНОЙ РЕГУЛИРОВКОЙ ЛЕВЫЕ

PORTAUTENSILE REGOLABILE
 CON SEDE PER LAMA DA TAGLIO, SINISTRO
 PORTE-OUTIL DE TRONCONNAGE
 AVEC REGLAGE EN HAUTEUR, A GAUCHE
 用于切割工具的刀柄高度可调, 左侧

DIN 69880 - AL

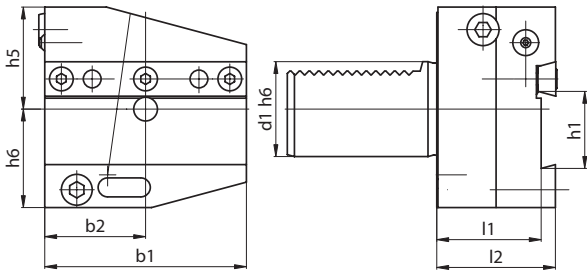

Spare parts on page 355 - Vedi ricambi a pag. 355 - Ver las piezas de repuesto a la pág. 355
 S. Ersatzteile auf Seite 355 - Voyez les pièces détachées à la page 355
 Запасные части на стр. 355 - 附件部分见 355 页

CODE N.	d1	b1	b2	h1	h5	h6	l1	l2
AL3026	30	70	35	26	32	39	44	50
AL4032	40	85	42.5	32	43	41.5	44	50

TOOLHOLDER FOR CUT OFF TOOLS ADJUSTABLE IN HEIGHT, LEFT

ABSTECHEMISSELHALTER, HÖHENEINSTELLBAR, LINKS
 PORTAHERRAMIENTAS AJUSTABLE CON ASIENTO
 PARA CUCHILLA DE CORTE, IZQUIERDO
 ДЕРЖАТЕЛИ ОТРЕЗНЫХ РЕЗЦОВ
 С ВЕРТИКАЛЬНОЙ РЕГУЛИРОВКОЙ ЛЕВЫЕ

PORTAUTENSILE REGOLABILE
 CON SEDE PER LAMA DA TAGLIO, SINISTRO
 PORTE-OUTIL DE TRONCONNAGE
 AVEC REGLAGE EN HAUTEUR, A GAUCHE
 用于切割工具的刀柄高度可调, 左侧

DIN 69880 - AL

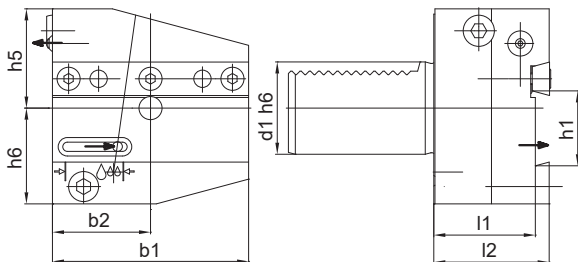

DIN 69880-AL



Spare parts on page 355 - Vedi ricambi a pag. 355 - Ver las piezas de repuesto a la pág. 355
 S. Ersatzteile auf Seite 355 - Voyez les pièces détachées à la page 355
 Запасные части на стр. 355 - 附件部分见 355 页

CODE N.	d1	b1	b2	h1	h5	h6	l1	l2
AL3026-IC	30	70	35	26	32	39	44	50
AL4026-IC	40	85	42.5	26	43	41.5	44	50
AL4032-IC	40	85	42.5	32	43	41.5	44	50

TOOLHOLDER FOR CUT OFF TOOLS ADJUSTABLE IN HEIGHT, UPSIDE-DOWN, RIGHT

ABSTECHEMISSELHALTER, HÖHENEINSTELLBAR, ÜBERKOPF RECHTS
 PORTAHERRAMIENTAS AJUSTABLE CON ASIENTO
 PARA CUCHILLA DE CORTE, INVERTIDO, DERECHO
 ДЕРЖАТЕЛИ ОТРЕЗНЫХ РЕЗЦОВ С ВЕРТИКАЛЬНОЙ
 РЕГУЛИРОВКОЙ ПЕРЕВЕРНУТЫЕ ПРАВЫЕ

PORTAUTENSILE REGOLABILE CON SEDE
 PER LAMA DA TAGLIO ROVESCiato, DESTRO
 PORTE-OUTIL DE TRONCONNAGE
 AVEC REGLAGE EN HAUTEUR, RENVERSE, DROITE
 用于切割工具的刀柄高度可调, 倒置, 右侧(左侧)

DIN 69880 - ARU

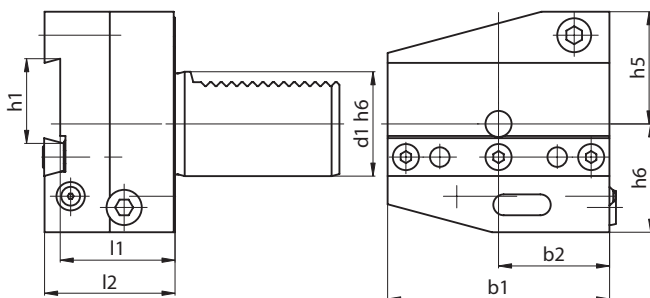

Spare parts on page 355 - Vedi ricambi a pag. 355 - Ver las piezas de repuesto a la pág. 355
 S. Ersatzteile auf Seite 355 - Voyez les pièces détachées à la page 355
 Запасные части на стр. 355 - 附件部分见 355 页

CODE N.	d1	b1	b2	h1	h5	h6	l1	l2
ARU3026	30	70	35	26	38	35	44	50
ARU4032	40	85	42.5	32	43	41.5	44	50

LONGITUDINAL TOOLHOLDER FOR BORING BARS

LÄNGSWERKZEUGHALTER FÜR BOHRSTANGEN FÜR STERNREVOLVER
 PORTAHERRAMIENTAS LONGITUDINAL PARA BARRAS
 ДЕРЖАТЕЛИ РАСТОЧНЫХ РЕЗЦОВ ПРОДОЛЬНЫЕ

PORTAUTENSILE LONGITUDINALE PER BARENI, PER TORRETTA RADIALE
 PORTE-OUTIL LONGITUDINAL POUR OUTILS A ALESER
 镗头柄水平式刀柄

DIN 69880 - PU1

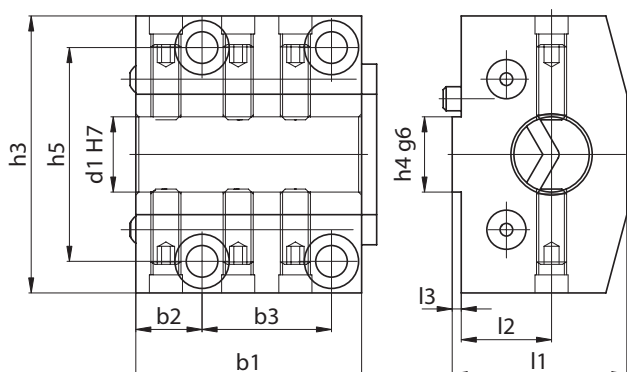

WITH INTERNAL COOLANT
 CON PASSAGGIO REFRIGERANTE INTERNO
 CO REFRIGERACION INTERNA
 MIT INNENKÜHLUNG
 AVEC ARROSAGE INTERNE
 С ВНУТРЕННИМ ПОДВОДОМ СОЖ
 内置冷却剂供应装置



Accessories
 Accessori
 Zubehör
 Accesorios
 Accessoires
 Принадлежности
 零件

CODE N.	d1	h3	h4	h5	b1	b2	b3	l1	l2	l3
PU1-20-25	25	74	20	57	60	17.5	34	48	25	3
PU1-20-32	32	74	20	57	60	17.5	34	48	25	3
PU1-25-20	20	92	25	71	75	22	43	58	30	3
PU1-25-25	25	92	25	71	75	22	43	58	30	3
PU1-25-32	32	92	25	71	75	22	43	58	30	3
PU1-25-40	40	92	25	71	75	22	43	58	30	3
PU1-25-50	50	92	25	71	75	22	43	73	38	3
PU1-32-25	25	115	32	90	95	26	57	73	35	3
PU1-32-32	32	115	32	90	95	26	57	73	35	3
PU1-32-40	40	115	32	90	95	26	57	73	35	3
PU1-32-50	50	115	32	90	95	26	57	73	35	3
PU1-32-60	60	115	32	90	95	26	57	83	40	3

LONGITUDINAL TOOLHOLDER WITH REVERSIBLE SQUARE SEAT

LÄNGSWERKZEUGHALTER MIT VIERKANTAUFNAHME FÜR STERNREVOLVER
 PORTAHERRAMIENTAS CON SEDE CUADRADA, REVERSIBLE, LONGITUDINAL
 РЕЗЦЕДЕРЖАТЕЛИ ПРОДОЛЬНЫЕ ДВУСТОРОННИЕ

PORTAUTENSILE A SEDE QUADRA, REVERSIBILE LONGITUDINALE PER TORRETTA RADIALE
 PORTE-OUTIL LONGITUDINAL AVEC SIEGE CARREE, REVERSIBLE
 可逆方座水平式刀柄

DIN 69880 - PU2

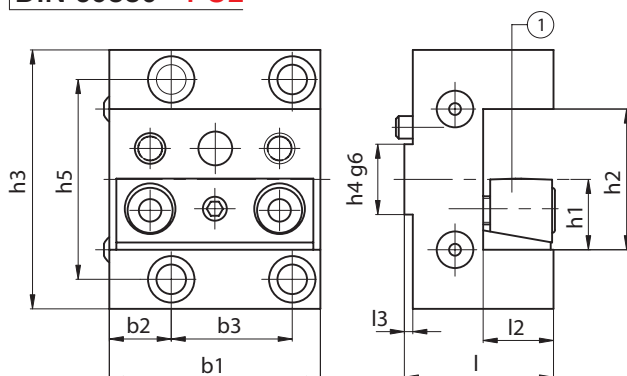

CODE N.	h1	h2	h3	h4	h5	b1	b2	b3	l1	l2	l3	CLAMPING PLATE
PU2-20-20	20	40	74	20	57	60	17.5	34	43	20	3	832-007160
PU2-25-25	25	50	92	25	71	75	22	43	53	25	3	832-007010
PU2-32-32	32	64	115	32	90	95	26	57	63	32	3	832-007170



KIT VDI TOOL HOLDERS

WERKZEUGHALTERSATZ KIT PORTA UTENSILI
 SETS DE PORTAHERRAMIENTAS VDI JEUX PORTE-OUTILS
 НАБОРЫ VDI ОПРАВКОВ VDI 刀柄组套



CODE DIN 69880	DESCRIPTION - DESCRIZIONE	
KIT VDI 30 DX	N°4 portaut.trasver.dx. (B1)	N°4 turning RH short (B1)
	N°1 portaut.trasv.rov.dx. (B3)	N°1 turning RH overhead (B3)
	N°1 portaut.longit.dx. (C1)	N°1 axial holder RH (C1)
	N°1 portapunte inserti Ø20 (E1)	N°1 U drill holder Ø20 (E1)
	N°1 portabareno Ø25 (E2)	N°1 boring bar holder Ø25 (E2)
	N°1 portabareno Ø20 (E2)	N°1 boring bar holder Ø20 (E2)
	N°1 portabareno Ø16 (E2)	N°1 boring bar holder Ø16 (E2)
	N°2 portapince ER32 (E4)	N°2 collet chucks ER32 (E4)
	N°1 bussola di riduzione Ø25-10	N°1 reduction Ø25-10
	N°1 bussola di riduzione Ø25-12	N°1 reduction Ø25-12
	N°10 pinze ER32 (Ø3 4 6 8 10 12 14 16 18 20)	N°10 collets ER32 (Ø3 4 6 8 10 12 14 16 18 20)
	N°1 chiave per ER32	N°1 wrench ER32

Der gleiche Satz kann mit Radial-und Längenwerkzeughalter Linksversion mit der Artikelnummer angeboten werden.

The same Kit can be supplied with LEFT radial and axial toolholders with code n°

El mismo set se puede suministrar con los portaherramientas radiales y longitudinales en la versión IZQUIERDA con el código

Такой же набор может быть сформирован и с левыми радиальными и аксиальными оправками под артикулом:

Le même jeux peut être fourni avec porte-outils radiaux et longitudinaux en la version gauche avec référence.

Lo stesso Kit può essere fornito con portautensili radiali e longitudinali in versione SINISTRA con codice

可提供相同的套件带产品号的左侧径向及轴向刀柄。

KITVDI30SX

11

KINTEK®



CODE DIN 69880	DESCRIPTION - DESCRIZIONE	
KIT VDI 40 DX	N°4 portaut.trasver.dx. (B1)	N°4 turning RH short (B1)
	N°1 portaut.trasv.rov.dx. (B3)	N°1 turning RH overhead (B3)
	N°1 portaut.longit.dx. (C1)	N°1 axial holder RH (C1)
	N°1 portapunte inserti Ø32 (E1)	N°1 U drill holder Ø32 (E1)
	N°1 portabareno Ø16 (E2)	N°1 boring bar holder Ø16 (E2)
	N°1 portabareno Ø25 (E2)	N°1 boring bar holder Ø25 (E2)
	N°1 portabareno Ø32 (E2)	N°1 boring bar holder Ø32 (E2)
	N°2 portapince ER32 (E4)	N°2 collet chucks ER32 (E4)
	N°1 bussola di riduzione Ø32-12	N°1 reduction Ø32-12
	N°1 bussola di riduzione Ø32-20	N°1 reduction Ø32-20
	N°1 bussola CM3	N°1 reduction MT3
	N°10 pinze ER32 (Ø3 4 6 8 10 12 14 16 18 20)	N°10 collets ER32 (Ø3 4 6 8 10 12 14 16 18 20)
	N°1 chiave per ER32	N°1 wrench ER32

Der gleiche Satz kann mit Radial-und Längenwerkzeughalter Linksversion mit der Artikelnummer angeboten werden.

The same Kit can be supplied with LEFT radial and axial toolholders with code n°

El mismo set se puede suministrar con los portaherramientas radiales y longitudinales en la versión IZQUIERDA con el código

Такой же набор может быть сформирован и с левыми радиальными и аксиальными оправками под артикулом:

Le même jeux peut être fourni avec porte-outils radiaux et longitudinaux en la version gauche avec référence.

Lo stesso Kit può essere fornito con portautensili radiali e longitudinali in versione SINISTRA con codice

可提供相同的套件带产品号的左侧径向及轴向刀柄。

KITVDI40SX



SPARE PARTS



COOLANT NOZZLES

SPRITZDÜSEN UGELLO REFRIGERANTE
 BOQUILLAS DE REFRIGERACION BUSE D'ARROSAGE
 СОПЛА ДЛЯ ПОДАЧИ СОЖ 冷却剂喷嘴

DIN 69880

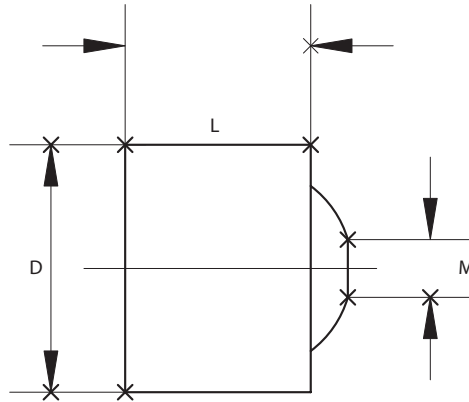

CODE N.	D	L	M
PWZ1005D6x4,5	6	5	M 2,5
PWZ1008D8x6	8	6	M 4
PWZ1008D10x7	10	7	M 5
PWZ1012D12x8	12	8	M 6
PWZ1012D14x10	14	9	M 8
PWZ1014D16x12	16	10	M 10

EXTENSION FOR COOLANT NOZZLES

SPRITZROHR PROLUNGHE UGELLO REFRIGERANTE
 EXTENSIONES PARA BOQUILLAS DE REFRIGERACION RALLONGE POUR BUSE D'ARROSAGE
 удлинители для сопл 加长冷却剂喷嘴

DIN 69880

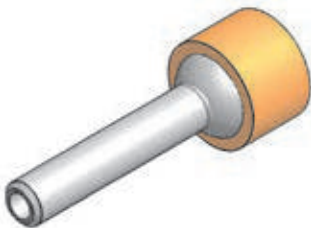

CODE N.	M	D	L
833-00151	M 4	1	30
833-00152	M 4	2	30
833-00153	M 5	2	30
833-00154	M 5	3	40
833-00155	M 6	2	35
833-00156	M 6	3	35
833-00157	M 6	4	50
833-00158	M 8	2	40
833-00159	M 8	3	40
833-00160	M 8	4	40
833-00161	M 8	5	50
833-00164	M 10	6	50



SPARE PARTS

ERSATZTEILE COMPONENTI
 PIEZAS DE REPUESTO PIECES DETACHEES
 ЗАПАСНЫЕ ЧАСТИ 附件

DIN 69880 - B1- B2 - B3 - B4

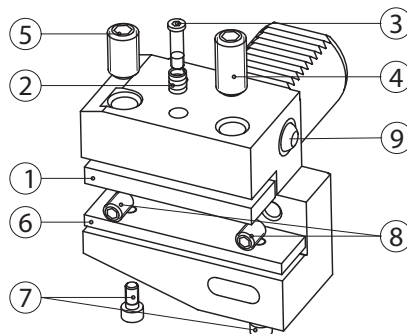

CODE N.	TOOL CLAMP PLATE	SPRING	Q	SCREW	Q	LOCKING SCREW	Q	LOCKING SCREW SHORT	SHIM PLATE	SCREW	Q	STOP SCREW
	1 	2 		3 		4 		5 	6 	7 		8
B..-16x12x...	832-002084	824-101010	1	811-302009	1	811-102047	1	811-102019	-	-	-	811-102020
B..-20x16x...	832-002003	824-101010	1	811-302004	1	811-102030	1	811-102029	832-003003	811-101016	1	811-102020
B..-25x16x...	832-002003	824-101010	1	811-302004	1	811-102030	1	811-102029	832-003003	811-101016	1	811-102020
B1-30x20x...	832-002012	824-101010	1	811-302004	1	811-102044	1	811-102043	832-003007	811-101016	1	811-102028
B2-30x20x...												
B3-30x20x...	832-002012	824-101010	1	811-302004	1	811-102045	1	811-102044	832-003007	811-101016	1	811-102028
B4-30x20x...												
B1-40x25x44	832-002019	824-101010	1	811-302004	1	811-102045	1	811-102044	832-003012	811-101016	2	811-102028
B2-40x25x44												
B3-40x25x44	832-002019	824-101010	1	811-302004	1	811-102047	1	811-102045	832-003033	811-101016	2	811-102028
B4-40x25x44												
B1-50x32x55	832-002025	824-101010	1	811-302004	1	811-102045	2	-	832-003016	811-101017	2	811-102036
B2-50x32x55												
B3-50x32x55	832-002025	824-101010	1	811-302004	1	811-102083	1	811-102047	832-003034	811-101017	2	811-102036
B4-50x32x55												
B1-60x32x60	832-002028	824-101020	1	811-302013	1	811-102054	2	-	832-003019	811-101017	2	811-102036
B2-60x32x60												
B3-60x32x60	832-002028	824-101020	1	811-302013	1	811-102057	1	811-102054	832-003019	811-101017	2	811-102036
B4-60x32x60												
B1-80x40x75	832-002034	824-101020	2	811-302013	2	811-102056	3	-	832-003021	811-101017	2	811-102036
B2-80x40x75												
B3-80x40x75	832-002034	824-101020	2	811-302013	2	811-102058	2	811-102056	832-003021	811-101017	2	811-102036
B4-80x40x75												

CODE N.	COOLANT NOOSE
	9
B...16x12...	PWZ1008D8X6
B1-20x16x...	PWZ1008D10X7
B2-20x16x...	PWZ1008D10X7
B3-20x16x...	PWZ1008D10X7
B4-20x16x...	PWZ1008D10X7
B1-25x16x...	PWZ1008D10X7
B2-25x16x...	PWZ1008D10X7
B3-25x16x...	PWZ1008D10X7
B4-25x16x40	PWZ1008D10X7
B4-25x16x30	PWZ1008D10X7
B..-30x20x...	PWZ1012D14X10
B..-40x25x44	PWZ1012D14X10
B..-50x32x55	PWZ1012D14X10
B..-60x32x60	PWZ1012D14X10
B..-80x40x75	PWZ1012D14X10

SPARE PARTS

ERSATZTEILE COMPONENTI
 PIEZAS DE REPUESTO PIECES DETACHEES
 ЗАПАСНЫЕ ЧАСТИ 附件

DIN 69880 - B5 - B6 - B7 - B8

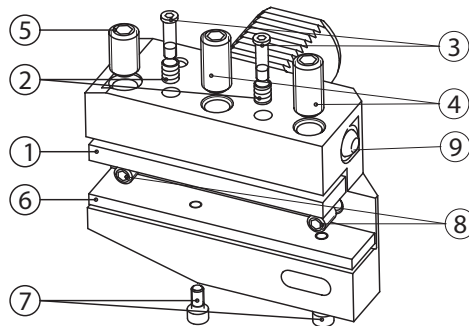

CODE N.	TOOL CLAMP PLATE	SPRING	Q	SCREW	Q	LOCKING SCREW	Q	LOCKING SCREW SHORT	SHIM PLATE	SCREW	Q	STOP SCREW
B...16x12x...	832-002051	824-101010	2	811-302009	2	811-402047	2	811-102019	-	-	-	811-102020
B...20x16x...	832-002006	824-101010	2	811-302004	2	811-102030	2	811-102029	832-003005	811-101016	1	811-102020
B...25x16x...	832-002006	824-101010	2	811-302004	2	811-102030	2	811-102029	832-003005	811-101016	1	811-102020
B5-30x20x...	832-002013	824-101010	2	811-302004	2	811-102044	2	811-102043	832-003009	811-101016	2	811-102028
B6-30x20x...												
B7-30x20x...	832-002013	824-101010	2	811-302004	2	811-102045	2	811-102044	832-003009	811-101016	1	811-102028
B8-30x20x...												
B5-40x25x44	832-002021	824-101010	2	811-302004	2	811-102045	2	811-102044	832-003014	811-101016	2	811-102028
B6-40x25x44												
B7-40x25x44	832-002021	824-101010	2	811-302004	2	811-102047	2	811-102045	832-003014	811-101016	2	811-102028
B8-40x25x44												
B5-50x32x55	832-002026	824-101010	2	811-302004	2	811-102045	3	-	832-003018	811-101017	2	811-102036
B6-50x32x55												
B7-50x32x55	832-002026	824-101010	2	811-302004	2	811-102083	2	811-102047	832-003018	811-101017	2	811-102036
B8-50x32x55												
B5-60x32x60	832-002029	824-101020	2	811-302013	2	811-102054	3	-	832-003020	811-101017	2	811-102036
B6-60x32x60												
B7-60x32x60	832-002029	824-101020	2	811-302013	2	811-102057	2	811-102054	832-003020	811-101017	2	811-102036
B8-60x32x60												
B5-80x40x75	832-002035	824-101020	2	811-302013	2	811-102056	3	-	832-003022	811-101017	2	811-102036
B6-80x40x75												
B7-80x40x75	832-002035	824-101020	2	811-302013	2	811-102058	2	811-102056	832-003022	811-101017	2	811-102036
B8-80x40x75												

CODE N.	COOLANT NOOSE
B...16x12x...	PWZ1008D8X6
B...20x16x...	PWZ1008D10X7
B...25x16x...	PWZ1008D10X7
B...30x20x...	PWZ1012D14X10
B...40x25x44	PWZ1012D14X10
B...50x32x55	PWZ1012D14X10
B...60x32x60	PWZ1012D14X10
B...80x40x75	PWZ1012D14X10

SPARE PARTS

ERSATZTEILE COMPONENTI
 PIEZAS DE REPUESTO PIECES DETACHEES
 ЗАПАСНЫЕ ЧАСТИ 附件

DIN 69880 - C1 - C2 - C3 - C4

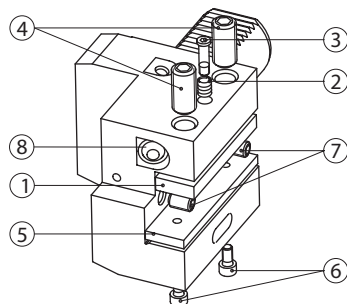

CODE N.	TOOL CLAMP PLATE	SPRING	Q	SCREW	Q	LOCKING SCREW	Q	SHIM PLATE	SCREW	Q	STOP SCREW
	1 	2 		3 		4 		5 	6 		7
C..-16x12x44	832-002090	824-101010	1	811-302009	1	811-402047	2	-	-	-	811-102020
C..-20x16x50	832-002004	824-101010	1	811-302004	1	811-102030	2	832-003002	811-101016	1	811-102020
C..-20x16x55	832-002003	824-101010	1	811-302004	1	811-102030	2	832-003003	811-101016	1	811-102020
C..-25x16x55	832-002003	824-101010	1	811-302004	1	811-102030	2	832-003003	811-101016	1	811-102020
C1-30x20x70	832-002012	824-101010	1	811-302004	1	811-102044	2	832-003007	811-101016	1	811-102028
C2-30x20x70											
C1-S-30x20/16	832-002008	824-101010	1	811-302004	1	811-102044	2	832-003198	811-101016	1	-
C2-S-30x20/16											
C3-30x20x70	832-002012	824-101010	1	811-302004	1	811-102045	2	832-003007	811-101016	1	811-102028
C4-30x20x70											
C1-40x25x85	832-002019	824-101010	1	811-302004	1	811-102045	2	832-003012	811-101016	2	811-102028
C2-40x25x85											
C1-S40x25/20	832-002058	824-101010	1	811-302004	1	811-102045	2	832-003200	811-101016	1	-
C2-S40x25/20											
C3-40x25x85	832-002019	824-101010	1	811-302004	1	811-102047	2	832-003012	811-101016	2	811-102028
C4-40x25x85											
C1-50x32x100	832-002025	824-101010	1	811-302004	1	811-102045	2	832-003016	811-101017	2	811-102036
C2-50x32x100											
C1-S50x32/25	832-002066	824-101010	1	811-302004	1	811-102047	2	832-003199	811-101017	2	-
C2-S50x32/25											
C3-50x32x100	832-002025	824-101010	1	811-302004	1	811-102083	2	832-003016	811-101017	2	811-102036
C4-50x32x100											
C1-60x32x125	832-002028	824-101020	1	811-302013	1	811-102054	2	832-003019	811-101017	2	811-102036
C2-60x32x125											
C1-S60x32	832-002160	824-101020	1	811-302013	1	811-102054	2	-	-	-	-
C2-S60x32											
C3-60x32x125	832-002028	824-101020	1	811-302013	1	811-102056	2	832-003019	811-101017	2	811-102036
C4-60x32x125											
C1-80x40x160	832-002036	824-101020	2	811-302013	2	811-102056	3	832-003023	811-101017	2	811-102036
C2-80x40x160											
C1-S80x40	832-002161	824-101020	1	811-302013	1	811-102056	2	-	-	-	-
C2-S80x40											
C3-80x40x160	832-002036	824-101020	2	811-302013	2	811-102058	3	832-003023	811-101017	2	811-102036
C4-80x40x160											

CODE N.	COOLANT NOOSE
	8
C...16x12x...	PWZ1005D6X4,5
C..-20x16x...	PWZ1008D10X7
C..-25x16x...	PWZ1008D10X7
C..-30x20x...	PWZ1012D14X10
C..-40x25x...	PWZ1012D14X10
C..-50x32x...	PWZ1012D14X10
C..-60x32x...	PWZ1012D14X10
C..-80x40x...	PWZ1012D14X10

SPARE PARTS

ERSATZTEILE COMPONENTI
 PIEZAS DE REPUESTO PIECES DETACHEES
 ЗАПАСНЫЕ ЧАСТИ 附件

DIN 69880 - D1-D2

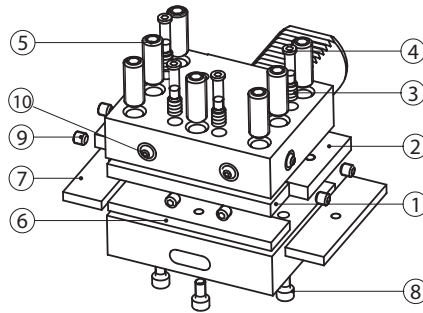

CODE N.	TOOL CLAMP PLATE (rad)	TOOL CLAMP PLATE (ax)	SPRING	Q	SCREW	Q	LOCKING SCREW	Q	SHIM PLATE (rad)	SHIM PLATE (ax)	SCREW	Q	STOP SCREW
	1 	2 	3 		4 		5 		6 	7 	8 		9
D.-25x16x48	832-002136	832-002098	824-101010	3	811-302004	3	811-102030	6	832-003004	832-003179	811-101016	3	811-102011
D.-30x20x60	832-002118	832-002009	824-101010	4	811-302004	4	811-102030	7	832-003008	832-003006	811-101016	3	811-102017
D1-40x25x72	832-002119	832-002015	824-101010	4	811-302004	4	811-102039	7	832-003013	832-003010	811-101016	3	811-102017
D2-40x25x72	832-002119	832-002015	824-101010	4	811-302004	4	811-102041	7	832-003013	832-003010	811-101016	3	811-102017
D1-50x32x85	832-002120	832-002023	824-101010	4	811-302004	4	811-102039	7	832-003017	832-003015	811-101017	3	811-102026
D2-50x32x85	832-002120	832-002023	824-101010	4	811-302004	4	811-102041	7	832-003017	832-003015	811-101017	3	811-102026
D1-60x32x110	832-002134	832-002071	824-101020	4	811-302013	4	811-102047	7	832-003025	832-003024	811-101017	6	811-102026
D2-60x32x110	832-002134	832-002071	824-101020	4	811-302013	4	811-102083	7	832-003025	832-003024	811-101017	6	811-102026
D1-80x40x140	832-002135	832-002033	824-101020	4	811-302013	4	811-102056	7	832-003093	832-003092	811-101017	6	811-102026
D2-80x40x140	832-002135	832-002033	824-101020	4	811-302013	4	811-102058	7	832-003093	832-003092	811-101017	6	811-102026

CODE N.	COOLANT NOOSE
	10
D..-25x16x48	PWZ1008D8X6
D..-30x20x60	PWZ1008D8X6
D..-40x25x72	PWZ1008D10X7
D..-50x32x85	PWZ1008D10X7
D..-60x32x85	PWZ1012D12X8
D..-80x40x140	PWZ1012D12X8

SPARE PARTS

ERSATZTEILE COMPONENTI
 PIEZAS DE REPUESTO PIECES DETACHEES
 ЗАПАСНЫЕ ЧАСТИ 附件

DIN 69880 - HK1

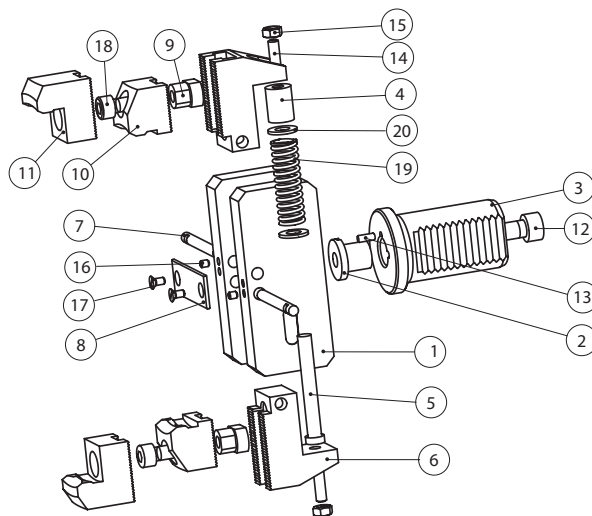

CODE N.	BODY	THREADED PAWL	SHANK	PAWL	PIN	JAW BASE	PIN	PLATE	DIE SLIDE	SHORT JAW	LONG JAW
	1	2	3	4	5	6	7	8	9	10	11
H116K	H1-1x20	H1-2x16	H1-3x16	H1-4x20-30	H1-5x30	H1-6x30	H1-7x30	H1-8x30	H1-9x30-40	H1-10x30-40	H1-11x30-40
H120K	H1-1x20	H1-2x20	H1-3x20	H1-4x20-30	H1-5x30	H1-6x30	H1-7x30	H1-8x30	H1-9x30-40	H1-10x30-40	H1-11x30-40
H125K	H1-1x30	H1-2x30-40	H1-3x25	H1-4x20-30	H1-5x30	H1-6x30	H1-7x30	H1-8x30	H1-9x30-40	H1-10x30-40	H1-11x30-40
H125KC	H1-1x30	H1-2x30-40	H1-3x25C	H1-4x20-30	H1-5x30	H1-6x30	H1-7x30	H1-8x30	H1-9x30-40	H1-10x30-40	H1-11x30-40
H130K	H1-1x30	H1-2x30-40	H1-3x30	H1-4x20-30	H1-5x30	H1-6x30	H1-7x30	H1-8x30	H1-9x30-40	H1-10x30-40	H1-11x30-40
H132KC	H1-1x30	H1-2x30-40	H1-3x32C	H1-4x20-30	H1-5x30	H1-6x30	H1-7x30	H1-8x30	H1-9x30-40	H1-10x30-40	H1-11x30-40
H140K	H1-1x40	H1-2x30-40	H1-3x40	H1-4x40	H1-5x40	H1-6x40	H1-7x40	H1-8x40	H1-9x30-40	H1-10x30-40	H1-11x30-40
H140KC	H1-1x40	H1-2x30-40	H1-3x40C	H1-4x40	H1-5x40	H1-6x40	H1-7x40	H1-8x40	H1-9x30-40	H1-10x30-40	H1-11x30-40
H150K	H1-1x50-60	H1-2x50-60	H1-3x50	H1-4x50-60	H1-5x50-60	H1-6x50-60	H1-7x50-60	H1-8x50-60	H1-9x50-60	H1-10x50-60	H1-11x50-60
H150KC	H1-1x50-60	H1-2x50-60	H1-3x50C	H1-4x50-60	H1-5x50-60	H1-6x50-60	H1-7x50-60	H1-8x50-60	H1-9x50-60	H1-10x50-60	H1-11x50-60
H160K	H1-1x50-60	H1-2x50-60	H1-3x60	H1-4x50-60	H1-5x50-60	H1-6x50-60	H1-7x50-60	H1-8x50-60	H1-9x50-60	H1-10x50-60	H1-11x50-60

CODE N.	SCREW	PIN	SCREW	NUT	SCREW	SCREW	SCREW	SPRING	WASHER
	12	13	14	15	16	17	18	19	20
H116K	811-401041	815-210090	811-102022	812-101004	811-102002	811-108006	811-101040	824-101050	813-101090
H120K	811-401111	815-210090	811-102022	812-101004	811-102002	811-108006	811-101040	824-101050	813-101090
H125K	811-101055	815-210090	811-102022	812-101004	811-102002	811-108006	811-101040	824-101050	813-101090
H125KC	811-101055	815-210090	811-102022	812-101004	811-102002	811-108006	811-101040	824-101050	813-101090
H130K	811-101055	815-210090	811-102022	812-101004	811-102002	811-108006	811-101040	824-101050	813-101090
H132KC	811-101055	815-210090	811-102022	812-101004	811-102002	811-108006	811-101040	824-101050	813-101090
H140K	811-101055	815-210090	811-102022	812-101004	811-102002	811-108006	811-101040	824-101060	813-101090
H140KC	811-101055	815-210090	811-102022	812-101004	811-102002	811-108006	811-101040	824-101060	813-101090
H150K	811-101068	815-210180	811-102030	812-101005	811-102002	811-108006	811-101052	824-101120	813-101100
H150KC	811-101068	815-210180	811-102030	812-101005	811-102002	811-108006	811-101052	824-101120	813-101100
H160K	811-101068	815-210180	811-102030	812-101005	811-102002	811-108006	811-101052	824-101120	813-101100

SPARE PARTS

ERSATZTEILE COMPONENTI
 PIEZAS DE REPUESTO PIECES DETACHEES
 ЗАПАСНЫЕ ЧАСТИ 附件

DIN 69880 - AR-AL-ARU-ALU

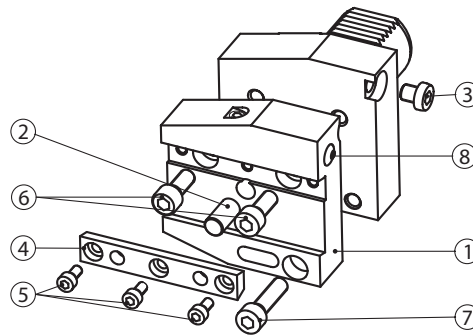

CODE N.	TOOL HOLDER PLATE	PIN	STOP SCREW	TOOL CLAMPING	SCREW	SCREW	SCREW	COOLANT NOOSE
	1	2	3	4	5	6	7	8
AR2026	117-120101	815-210010	811-303103	832-002097	811-101016	811-101029	811-101031	PWZ1008D8X6
AL2026	117-220101	815-210010	811-303103	832-002097	811-101016	811-101029	811-101031	PWZ1008D8X6
AR2526	117-125101	815-210010	811-303103	832-002097	811-101016	811-101029	811-101031	PWZ1008D8X6
AL2526	117-225101	815-210010	811-303103	832-002097	811-101016	811-101029	811-101031	PWZ1008D8X6
ARU2526	117-325101	815-210010	811-303103	832-002145	811-101016	811-101029	811-101031	PWZ1008D8X6
ALU2526	117-425101	815-210010	811-303125	832-002145	811-101016	811-101029	811-101031	PWZ1008D8X6
AR3026	117-130101	815-210010	811-303011	832-002037	811-101016	811-101040	811-101042	PWZ1008D10X7
AL3026	117-230101	815-210010	811-303011	832-002037	811-101016	811-101040	811-101042	PWZ1008D10X7
ARU3026	117-330101	815-210010	811-303011	832-002037	811-101016	811-101040	811-101042	PWZ1008D10X7
ALU3026	117-430101	815-210010	811-303011	832-002037	811-101016	811-101040	811-101042	PWZ1008D10X7
AR4026	117-140101	815-210020	811-303011	832-002038	811-101016	811-101040	811-101042	PWZ1008D10X7
AL4026	117-240101	815-210020	811-303011	832-002038	811-101016	811-101040	811-101042	PWZ1008D10X7
ARU4026	117-340101	815-210020	811-303011	832-002038	811-101016	811-101040	811-101042	PWZ1008D10X7
ALU4026	117-440101	815-210020	811-303011	832-002038	811-101016	811-101040	811-101042	PWZ1008D10X7
AR4032	117-140111	815-210020	811-303011	832-002039	811-101016	811-101040	811-101042	PWZ1008D10X7
AL4032	117-240111	815-210020	811-303011	832-002039	811-101016	811-101040	811-101042	PWZ1008D10X7
ARU4032	117-340111	815-210020	811-303011	832-002039	811-101016	811-101040	811-101042	PWZ1008D10X7
ALU4032	117-440111	815-210020	811-303011	832-002039	811-101016	811-101040	811-101042	PWZ1008D10X7
AR5026	117-150101	815-210020	811-303011	832-002040	811-101027	811-101040	811-101042	PWZ1012D14X10
AL5026	117-250101	815-210020	811-303011	832-002040	811-101027	811-101040	811-101042	PWZ1012D14X10
ARU5026	117-350101	815-210020	811-303011	832-002040	811-101027	811-101040	811-101042	PWZ1012D14X10
ALU5026	117-450101	815-210020	811-303011	832-002040	811-101027	811-101040	811-101042	PWZ1012D14X10
AR5032	117-150111	815-210020	811-303011	832-002041	811-101027	811-101040	811-101042	PWZ1012D14X10
AL5032	117-250111	815-210020	811-303011	832-002041	811-101027	811-101040	811-101042	PWZ1012D14X10
ARU5032	117-350111	815-210020	811-303011	832-002041	811-101027	811-101040	811-101042	PWZ1012D14X10
ALU5032	117-450111	815-210020	811-303011	832-002041	811-101027	811-101040	811-101042	PWZ1012D14X10
AR6032	117-160101	815-210030	811-303012	832-002042	811-101027	811-101052	811-101054	PWZ1012D14X10
AL6032	117-260101	815-210030	811-303012	832-002042	811-101027	811-101052	811-101054	PWZ1012D14X10
ARU6032	117-360101	815-210030	811-303012	832-002042	811-101027	811-101052	811-101054	PWZ1012D14X10
ALU6032	117-460101	815-210030	811-303012	832-002042	811-101027	811-101052	811-101054	PWZ1012D14X10



ACCESSORIES



ADAPTOR

REDUZIERHÜLSE BUSSOLA DI RIDUZIONE
 CASQUILLOS DE REDUCCION DOUILLE DE REDUCTION
 ПЕРЕХОДНИКИ 接头

E2-1

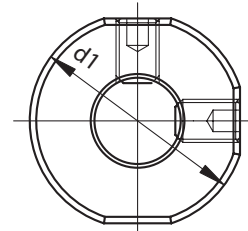
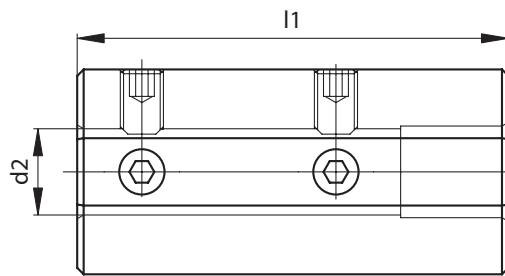

HRC55

CODE N.	d1	d2	l1
E2-1-20x6	20	6	60
E2-1-20x8	20	8	60
E2-1-20x10	20	10	60
E2-1-20x12	20	12	60
E2-1-25x6	25	6	60
E2-1-25x8	25	8	60
E2-1-25x10	25	10	60
E2-1-25x12	25	12	60
E2-1-32x6	32	6	70
E2-1-32x8	32	8	70
E2-1-32x10	32	10	70
E2-1-32x12	32	12	70
E2-1-32x16	32	16	70
E2-1-32x20	32	20	70
E2-1-40x6	40	6	80
E2-1-40x8	40	8	80
E2-1-40x10	40	10	80
E2-1-40x12	40	12	80
E2-1-40x16	40	16	80
E2-1-40x20	40	20	80
E2-1-40x25	40	25	80
E2-1-50x12	50	12	90
E2-1-50x16	50	16	90
E2-1-50x20	50	20	90
E2-1-50x25	50	25	90
E2-1-50x32	50	32	90

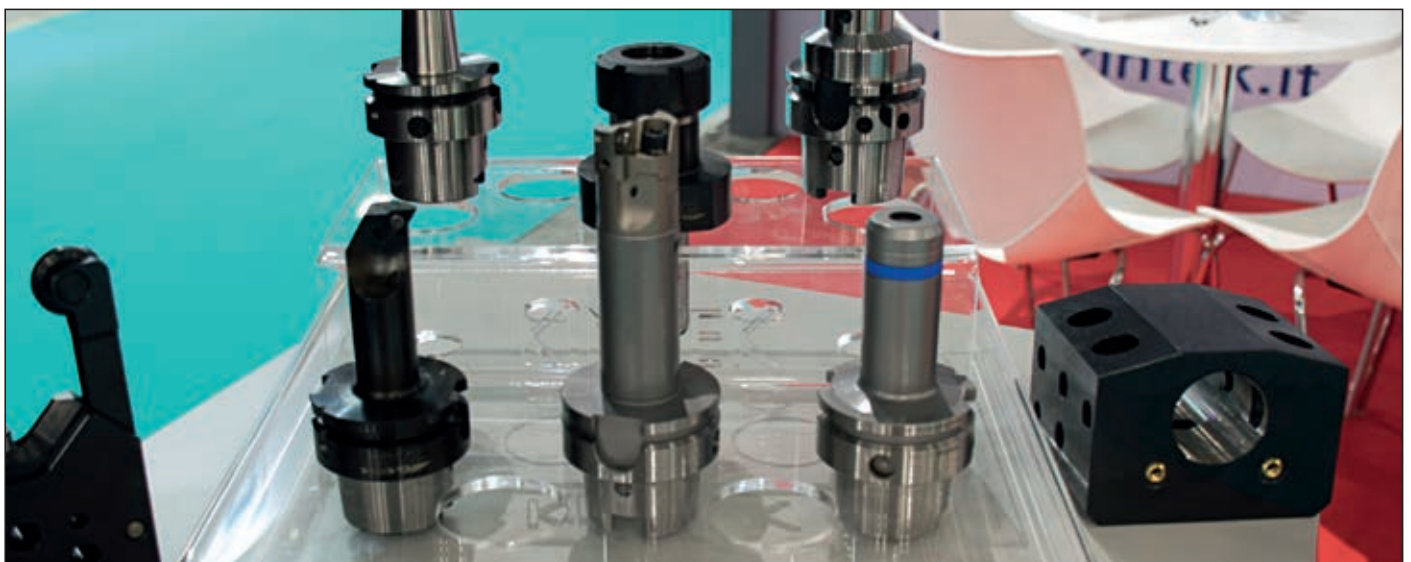

ADAPTOR, MORSE TAPER

REDUZIERHÜLSE, MORSEKEGEL BUSSOLA DI RIDUZIONE, CONO MORSE
 CASQUILLOS DE REDUCCION, CONO MORSE DOUILLE DE REDUCTION, CONE MORSE
 ПЕРЕХОДНИКИ ДЛЯ КОНУСА МОРЗЕ 接头莫氏锥度柄

E2-3

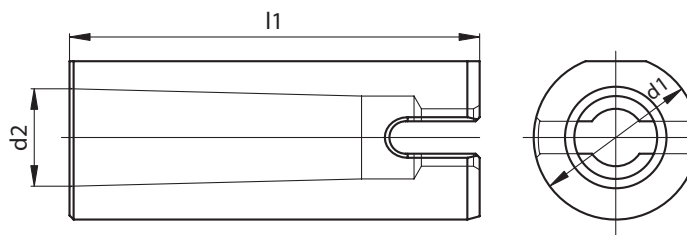

HRC55

CODE N.	d1	MK	d2	l1
E2-3-20x1	20	1	12.065	60
E2-3-20x2	20	2	17.780	90
E2-3-32x1	32	1	12.065	60
E2-3-32x2	32	2	17.780	90
E2-3-40x2	40	2	17.780	90
E2-3-40x3	40	3	23.825	100
E2-3-40x4	40	4	31.267	120
E2-3-50x2	50	2	17.780	90
E2-3-50x3	50	3	23.825	100
E2-3-50x4	50	4	31.267	120

MORSE TAPER ADAPTER

M.K. REDUZIERHÜLSE, MIT ANSCHLAG BUSSOLA DI RIDUZIONE CONO MORSE CON BATTUTA
 CASQUILLOS DE REDUCCION, CONO MORSE CON TOPE DOUILLE DE REDUCTION, CONE MORSE
 ПЕРЕХОДНИКИ ДЛЯ КОНУСА МОРЗЕ 莫氏锥度接头

114

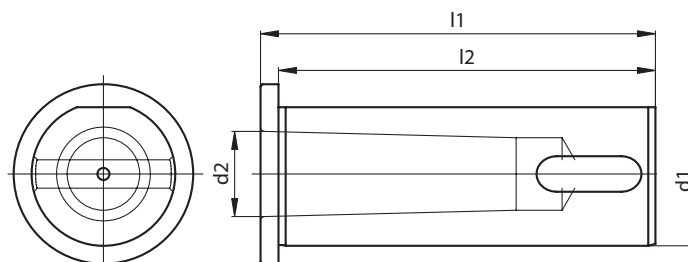

HRC55

CODE N.	d1	MK	d2	l1	l2
114-33208	32	1	12.065	90	85
114-33209	32	2	17.780	90	85
114-33210	32	3	23.825	100	95
114-34008	40	2	17.780	110	105
114-34009	40	3	23.825	110	105
114-34010	40	4	31.267	125	120
114-35004	50	2	17.780	130	125
114-35005	50	3	23.825	130	125
114-35006	50	4	31.267	130	125
114-36007	60	3	23.825	140	130
114-36008	60	4	31.267	140	130
114-36009	60	5	44.399	155	145

CYLINDRICAL BUSHING FOR BORING BAR HOLDERS TYPE

ZYLINDRISCHE REDUZIERHÜLSE MIT ANSCHLAG FÜR BOHRSTANGENHALTER TYP
 CASQUILLO DE REDUCCION CILINDRICO CON TOPE, PARA PORTABARRAS
 ПЕРЕХОДНИКИ ЦИЛИНДРИЧЕСКИЕ К ДЕРЖАТЕЛЯМ ТИПА ДЛЯ РАСТОЧНЫХ РЕЗЦОВ

BUSSOLA DI RIDUZIONE CILINDRICA CON BATTUTA, PER PORTABARENI
 DOUILLE DE REDUCTION CYLINDRIQUES POUR PORTE-BARRES D'ALEPAGE
 型搪孔柄圆柱套管

115 - 165

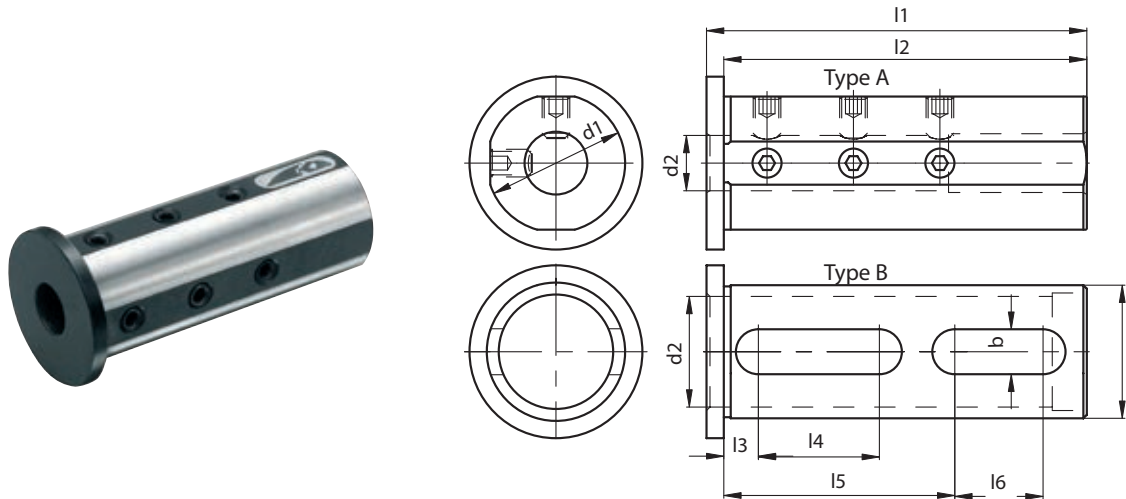

TYPE A HRC55 - TYPE B HRC32

CODE N.	d1	d2	l1	l2	l3	l4	l5	l6	b	TYPE
115-62573	25	6	65	60						A
115-62538	25	8	65	60						A
115-62539	25	10	65	60						A
115-62540	25	12	65	60						A
115-62541	25	16	65	60	9	13	37	12	11	B
165-63222	32	6	90	85						A
115-63260	32	8	90	85						A
115-63261	32	10	90	85						A
115-63211	32	12	90	85						A
115-63212	32	16	90	85						A
115-63213	32	20	90	85						A
115-63214	32	25	90	85	9	25	52	22	11	B
165-64074	40	6	110	105						A
115-64043	40	8	110	105						A
115-64044	40	10	110	105						A
115-64045	40	12	110	105						A
115-64046	40	16	110	105						A
115-64047	40	20	110	105						A
115-64048	40	25	110	105						A
115-64049	40	32	110	105	10	35	65	28	13	B
115-65053	50	12	130	125						A
115-65013	50	16	130	125						A
115-65014	50	20	130	125						A
115-65015	50	25	130	125						A
115-65016	50	32	130	125						A
115-65017	50	40	130	125	10	45	75	37	13	B
115-66017	60	20	140	135						A
115-66018	60	25	140	135						A
115-66019	60	32	140	135						A
115-66020	60	40	140	135						A
115-66021	60	50	140	135	15	40	83	28	13	B
115-68006	80	25	150	145						A
115-68007	80	32	150	145						A
115-68008	80	40	150	145						A
115-68009	80	50	150	145						A
115-68010	80	60	150	145	25	30	80	15	14	B

HEADED BORING BAR SLEEVES WITH SLOT

REDUZIERHÜLSE MIT LANGSCHLITZ
UND SCRAUBE AUF DEM BUND
CASQUILLO DE REDUCCION
CON OJAL Y TORNILLO EN EL TOPE
ПЕРЕХОДНИКИ К ДЕРЖАТЕЛЯМ ДЛЯ
РАСТОЧНЫХ РЕЗЦОВ С РЕЗЬБОЙ И ОТВЕРСТИЕМ

BUSSOLE DI RIDUZIONE CON ASOLA
E GRANO SULLA BATTUTA
DOUILLES DE REDUCTION
AVEC RAINURE ET VIS SUR LA BRIDE
帶槽的有頭鏜杆套筒

115 - 165

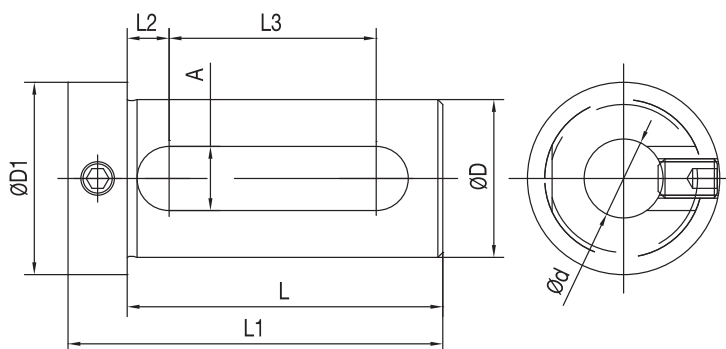

CODE N.	D	d	L	L1	L2	L3	A	D1
115-62044	20	8	50	60	7	29	11	28
115-62045	20	10	50	60	7	29	11	28
115-62046	20	12	50	60	7	29	11	28
115-62047	20	16	50	60	7	29	11	28
165-62545	25	12	55	67	8	32	13	33
165-62547	25	16	55	67	8	32	13	33
165-62549	25	20	55	67	8	32	13	33
165-63347	32	16	65	77	8	42	13	39
165-63349	32	20	65	77	8	42	13	39
165-63350	32	25	65	77	8	42	13	39
165-64241	40	16	75	89	9	51	14	48
165-64243	40	20	75	89	9	51	14	48
165-64244	40	25	75	89	9	51	14	48
165-64245	40	32	75	89	9	51	14	48
165-65017	50	25	85	99	9	61	14	60
165-65018	50	32	85	99	9	61	14	60
165-65019	50	40	85	99	9	61	14	60
165-66056	60	25	95	109	9	71	14	70
165-66057	60	32	95	109	9	71	14	70
165-66058	60	40	95	109	9	71	14	70
165-66059	60	50	95	109	9	71	14	70

TOOL HOLDER BUSHING

ZYLINDRISCHE REDUZIERHÜLSE MIT ANSCHLAG
CASQUILLO DE REDUCCION CILINDRICO CON TOPE
ЦИЛИНДРИЧЕСКИЕ ПЕРЕХОДНИКИ

BUSSOLA DI RIDUZIONE CILINDRICA CON BATTUTA, TAGLIATA
DOUILLE DE REDUCTION CYLINDRIQUE
刀柄套管

RZ

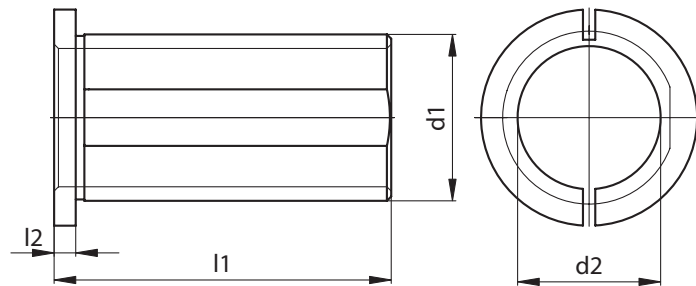

HRC32

CODE N.	d1	d2	l1	l2
RZ-20x08	20	8	30	4
RZ-20x10	20	10	30	4
RZ-20x12	20	12	30	4
RZ-20x16	20	16	30	4
RZ-25x08	25	8	40	4
RZ-25x10	25	10	40	4
RZ-25x12	25	12	40	4
RZ-25x16	25	16	40	4
RZ-25x20	25	20	40	4
RZ-32x08	32	8	50	4
RZ-32x10	32	10	50	4
RZ-32x12	32	12	50	4
RZ-32x16	32	16	50	4
RZ-32x20	32	20	50	4
RZ-32x25	32	25	50	4
RZ-40x10	40	10	78	4
RZ-40x12	40	12	78	4
RZ-40x16	40	16	78	4
RZ-40x20	40	20	78	4
RZ-40x25	40	25	78	4
RZ-40x32	40	32	78	4
RZ-50x20	50	20	88	4
RZ-50x25	50	25	88	4
RZ-50x32	50	32	88	4
RZ-50x40	50	40	88	4
RZ-60x25	60	25	92	4
RZ-60x32	60	32	92	4
RZ-60x40	60	40	92	4
RZ-60x50	60	50	92	4

- The elastic clamping reduces the tool vibrations.
- Questo tipo di chiusura elastica riduce le vibrazioni dell'utensile.
- Durch die elastische Spannung werden die Vibrationen des Werkzeuges gedämpft.
- Ese tipo de cierre elástico reduce las vibraciones de la herramienta
- Les vibrations de l'outil sont reduites par le serrage elastique.
- Гибкое соединение снижает вибрацию инструмента.
- 弹性夹头降低了工具的震动

CYLINDRICAL BUSHING FOR BORING BAR HOLDERS TYPE E2

ZYLINDRISCHE REDUZIERHÜLSE MIT ANSCHLAG
 FÜR ALLE BOHRSTANGENHALTER TYP E2
 CASQUILLO DE REDUCCION CILINDRICO CON TOPE,
 PARA PORTABARRAS DE TIPO E2
 ЦИЛИНДРИЧЕСКИЕ ПЕРЕХОДНИКИ
 К ДЕРЖАТЕЛЯМ ТИПА E2 ДЛЯ РАСТОЧНЫХ РЕЗЦОВ

BUSSOLA DI RIDUZIONE CILINDRICA CON
 BATTUTA, PER PORTABARENI E2
 DOUILLES DE REDUCTION CYLINDRIQUES
 POUR PORTE-BARRES D'ALEPAGE E2
 E2 型搪孔柄圆柱套管

165

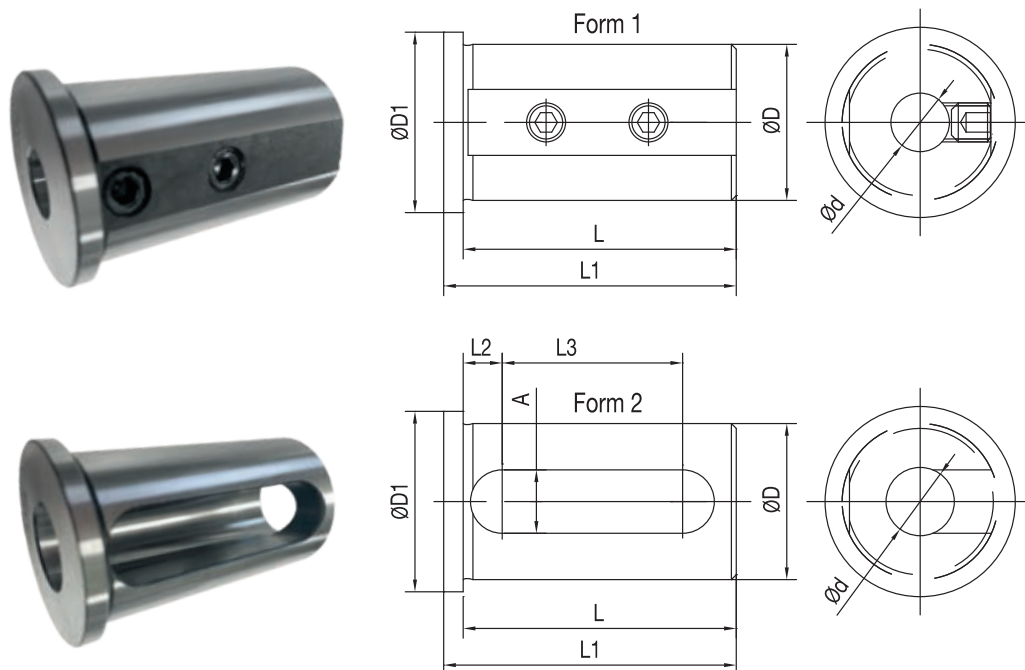

CODE N.	D	d	FORM	L	L1	L2	L3	A	D1
165-62551	25	8	1	46	50	-	-	-	30
165-62552	25	10	1	46	50	-	-	-	30
165-62553	25	12	1	46	50	-	-	-	30
165-62555	25	16	2	46	50	8	27	13	30
165-62557	25	20	2	46	50	8	27	13	30
165-63352	32	8	1	56	60	-	-	-	37
165-63353	32	10	1	56	60	-	-	-	37
165-63354	32	12	1	56	60	-	-	-	37
165-63356	32	16	2	56	60	8	37	13	37
165-63358	32	20	2	56	60	8	37	13	37
165-63359	32	25	2	56	60	8	37	13	37
165-64247	40	8	1	71	75	-	-	-	45
165-64248	40	10	1	71	75	-	-	-	45
165-64249	40	12	1	71	75	-	-	-	45
165-64251	40	16	2	71	75	8	52	13	45
165-64253	40	20	2	71	75	8	52	13	45
165-64254	40	25	2	71	75	8	52	13	45
165-64255	40	32	2	71	75	8	52	13	45

COLLET CHUCKS WITH COOLANT HOLES

SPANNZANGENAUFNAHMEN FÜR INNENKÜHLUNG PORTAPINZE CON FORI DI LUBRIFICAZIONE
 PORTAPINZAS CON AGUJEROS DE REFRIGERACION PORTE-PINCES AVEC ARROSAGE CENTRAL
 ЦАНГОВЫЕ ПАТРОНЫ С ВНУТРЕННИМ ПОДВОДОМ СОЖ 带冷却剂孔的弹簧夹头

NC

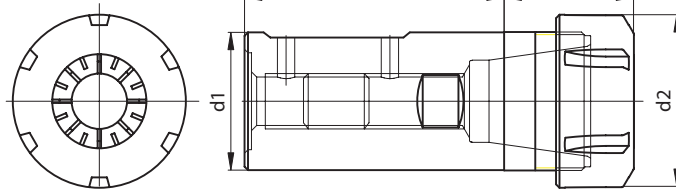

CODE N.	DESCRIPTION	RANGE	d1	d2	l1	l2
214-35170	NC32L70ER25	1-16	32	42	70	32
214-35171	NC32L70ER32	2-20	32	50	70	38
214-35172	NC40L75ER32	2-20	40	50	75	38
214-35173	NC40L75ER40	3-26	40	63	75	55

BLANKING PLUG

VERSCHLUSSTOPFEN TAMPONE DI PROTEZIONE
 TAPON DE PROTECCION BOUCHON DE PROTECTION
 ЗАГЛУШКИ 切断栓

Z2

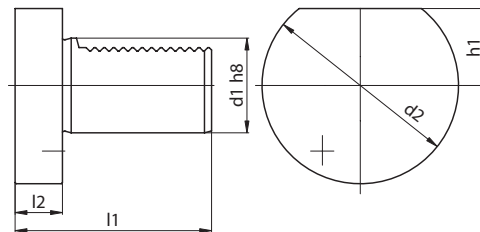

- Available either in plastic or in steel
* Z2-25S is only available in steel
- Fornibili sia in acciaio sia in plastica
* Z2-25S fornibili solo in acciaio
- Se suministran tanto en acero como en plástico * Z2-25S es disponible solo en acero
- Lieferbar sowohl aus Stahl als auch aus Plastik * Z2-25S nur aus Stahl
- Disponible soit en acier soit en plastique * Z2-25S seulement en acier
- Возможно изготовление из стали или пластика.
* Z2-25S только из стали
- 材料可为塑料或钢材。
* 只有钢材制造的产品才提供 Z2-25S

CODE N.	d1	d2	h1	l1	l2
Z2-16 S/P	16	40	18	45	13
Z2-20 S/P	20	50	23	56	16
Z2-30 S/P	30	68	28	71	16
Z2-40 S/P	40	83	32.5	83	20
Z2-50 S/P	50	98	35	98	20
Z2-60 S/P	60	123	42.5	114	20

S: Steel - Acciaio - Stahl - Acero
 Acier - Сталь - 钢

P: Plastic - Plastica - Plastik - Plástico
 Plastique - Пластик - 塑料

CYLINDRICAL BAR STOP

WERKSTOFFANSCHLAG MIT ZYLINDERSCHAFT LÄNGENEINSTELLBAR FERMOBARRA CILINDRICO REGOLABILE
 PARADOR DE BARRAS CILINDRICOS AJUSTABLES PORTE-BUTEES CYLINDRIQUES
 УПОРЫ С ЦИЛИНДРИЧЕСКИМ ХВОСТОВИКОМ 圆柱式制动杆

CW

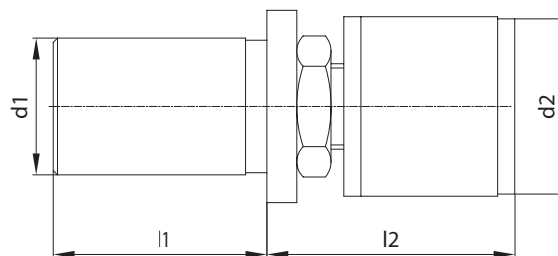

CODE N.	d1	d2	l1	l2
CW-2534	25	34	50	65-100
CW-3242	32	42	50	55-90
CW-4042	40	42	70	55-90

CYLINDRICAL REVOLVING BAR STOP WITH SHOCK ABSORBER

WERKSTOFFANSCHLAG MIT ZYLINDERSCHAFT
GEDÄMPFT LÄNGENEINSTELLBAR
PARADOR DE BARRAS CILINDRICOS AJUSTABLES AMORTIZADOS
УПОРЫ ВРАЩАЮЩИЕСЯ С ЦИЛИНДРИЧЕСКИМ
ХВОСТОВИКОМ С АМОРТИЗАЦИЕЙ

FERMOBARRA CILINDRICA
REGOLABILI AMMORTIZZATI
PORTE-BUTEES, CYLINDRIQUES, AMORTIS
圆柱式可旋转制动杆带减震器

CW-AM

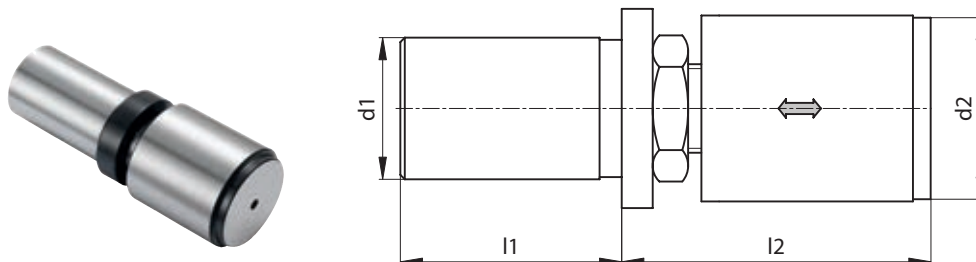

CODE N.	d1	d2	l1	l2
CW-2542-AM	25	42	50	62-97
CW-3242-AM	32	42	50	62-97
CW-4042-AM	40	42	70	62-97

ASSEMBLY SUPPORTS

MONTAGELBLOK SUPPORTO DI MONTAGGIO
SOPORTE DE MONTAJE SUPPORTS D'ASSEMBLAGE
СТОЙКА ДЛЯ СБОРКИ ИНСТРУМЕНТА 组件支架



VDI	CODE N.
16	237-32190
20	237-32290
25	237-32390
30	237-32490
40	237-32590
50	237-32690
60	237-32790
80	237-32890

This system allows the assembly and disassembly operations of the VDI toolholders in horizontal and vertical position. This is a very simple system for tool handling.

Questo sistema molto semplice consente il montaggio e lo smontaggio dei portautensili VDI (secondo la normativa DIN 69880) sia in orizzontale che in verticale. È un sistema che offre la massima semplicità d'uso per la manipolazione degli utensili.

Dieses unkomplizierte System erlaubt die schnelle Montage und Demontage von VDI Werkzeughaltern (gemäß DIN 69880) in horizontaler und vertikaler Lage. Dieses System ist sehr einfach zu bedienen, und erlaubt sicheres Bestücken der Werkzeuge.

Ese sistema muy sencillo permite el montaje y el desmontaje de los portaherramientas VDI (de acuerdo con la normativa DIN69880) tanto en horizontal como en vertical. Es un sistema que ofrece la máxima facilidad de uso para la manipulación de las herramientas.

Il permet d'effectuer toutes les opérations de montage et de démontage des porte outils VDI (DIN 69880) soit en horizontal qui en vertical. Ce système est très simple à utiliser pour la manipulation des outils.

Устройство позволяет производить сборку и демонтаж инструмента как в горизонтальном, так и в вертикальном положении. Эта система обслуживания инструмента очень проста в обращении.

这一系统允许将 VDI 刀柄以水平或垂直的方向进行安装和拆除操作。对于工具处理，这是一种非常简单的系统。

