

KINTEK®

TOOLHOLDERS FOR CNC LATHES (BMT, BOLT-ON, VDI DIN69880)
PORTAUTENSILI PER TORNI CNC (BMT, BOLT-ON, VDI DIN69880)



TOOLHOLDERS FOR CNC LATHES
(BMT, BOLT-ON, VDI DIN69880)



PORTAUTENSILI PER TORNII CNC
(BMT, BOLT-ON, VDI DIN69880)



CNC-DREHEMASCHINEN
(BMT, BOLT-ON, VDI DIN69880)



PORTA-HERRAMIENTAS PARA TORNOS CNC
(BMT, BOLT-ON, VDI DIN69880)



PORTE-OUTILS POUR TOURS CNC
(BMT, BOLT-ON, VDI DIN69880)



РЕЗЦЕДЕРЖАТЕЛИ ДЛЯ
ТОКАРНЫХ СТАНКОВ С ЧПУ
(BMT, BOLT-ON, VDI DIN69880)



数控车床刀柄
BMT, BOLT-ON, VDI DIN69880



TOOLHOLDERS FOR CNC LATHES (BMT, BOLT-ON, VDI DIN69880)

BIGLIA TOOLHOLDERS
PORTAUTENSILI BIGLIA

Pag. 369

CMZ TOOLHOLDERS
PORTAUTENSILI CMZ

Pag. 380

DMG MORI CMZ TOOLHOLDERS
GOODWAY TOOLHOLDERS
PORTAUTENSILI DMG MORI CMZ
PORTAUTENSILI GOODWAY

Pag. 386

OKUMA HAAS TOOLHOLDERS
PORTAUTENSILI OKUMA HAAS

Pag. 443

NAKAMURA TOME CMZ TOOLHOLDERS
PORTAUTENSILI NAKAMURA CMZ

Pag. 484

DOOSAN PUMA TOOLHOLDERS
BMT 45 /55/65/75
PORTAUTENSILI DEWOO PUMA
BMT 45 /55/65/75

Pag. 525

MAZAK TOOLHOLDERS
PORTAUTENSILI MAZAK

Pag. 591

BIGLIA

B301/445/470/501(Y-S)
510/545/550/565/650/658
1200/446/465/745
765-B750/1250 16 ST.

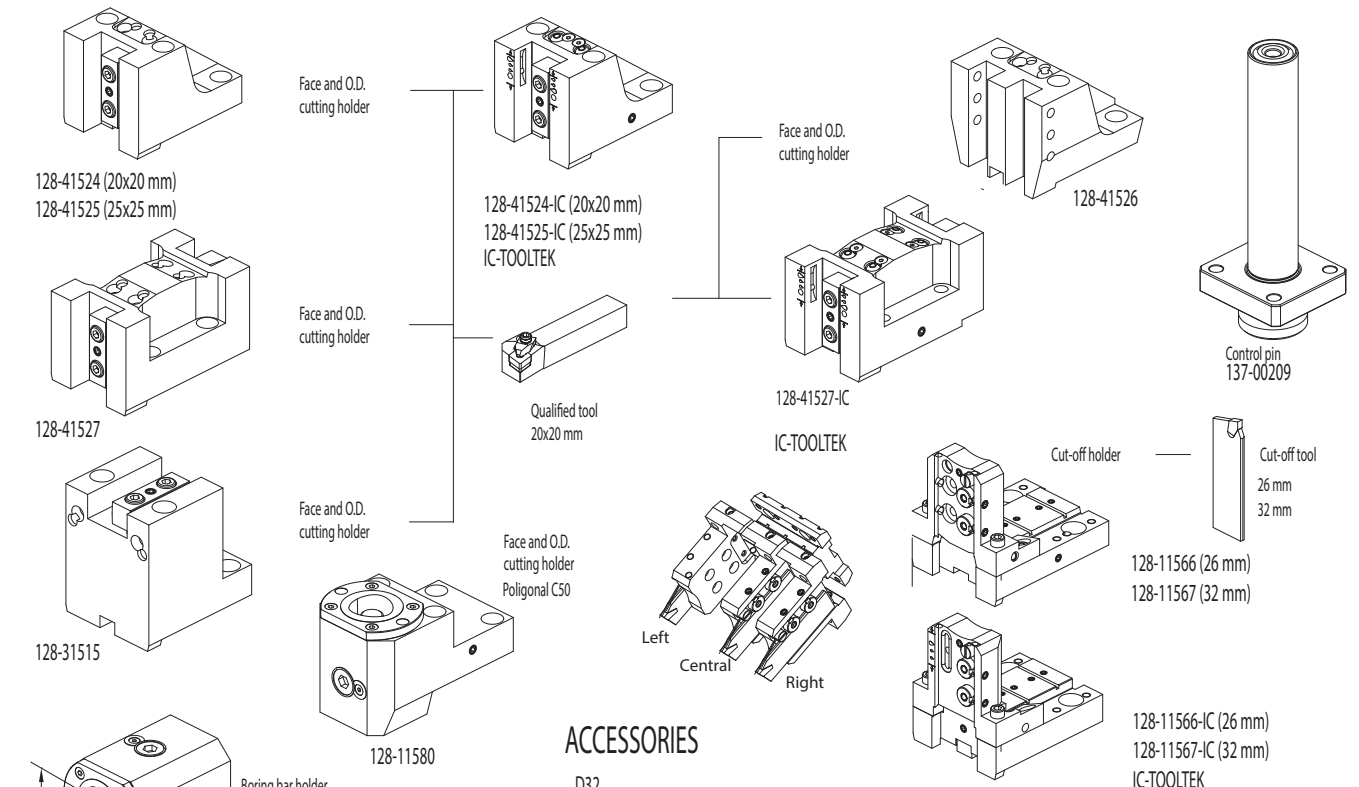

ACCESSORIES

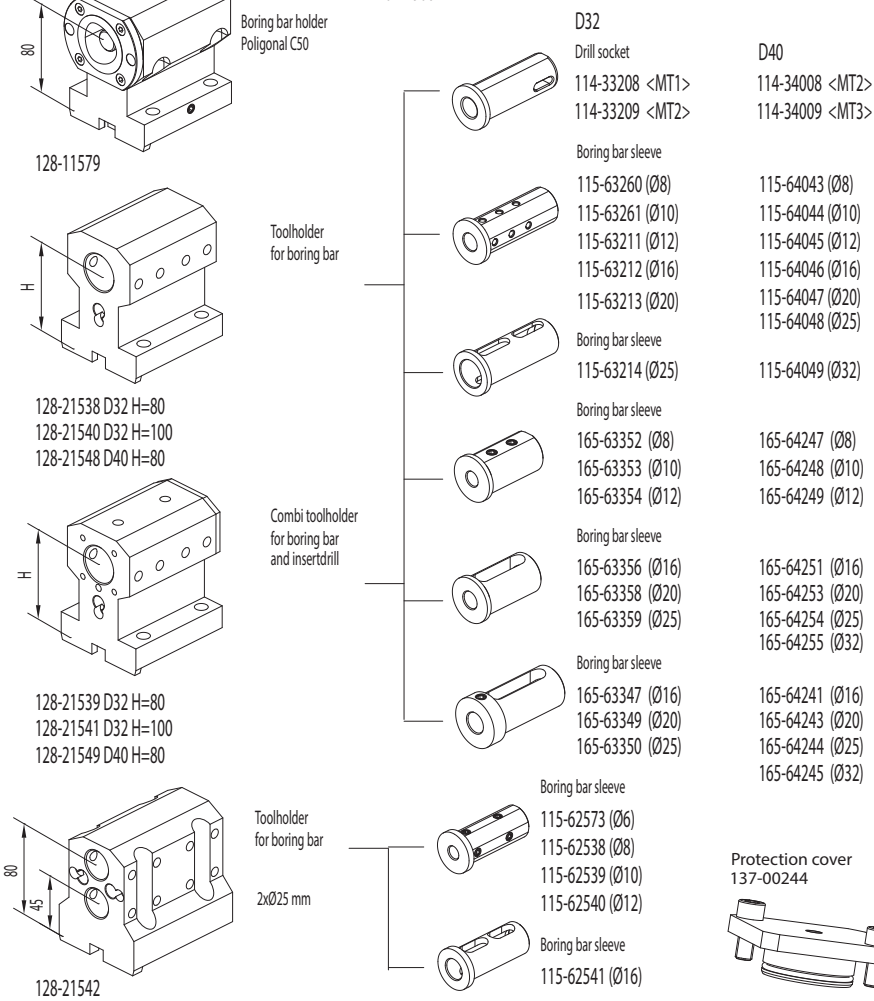

FAST-IN
Driven tools



CONNECTION

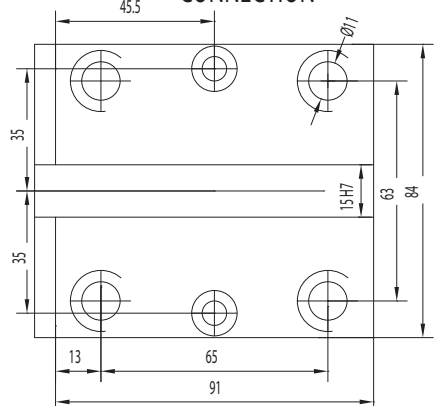



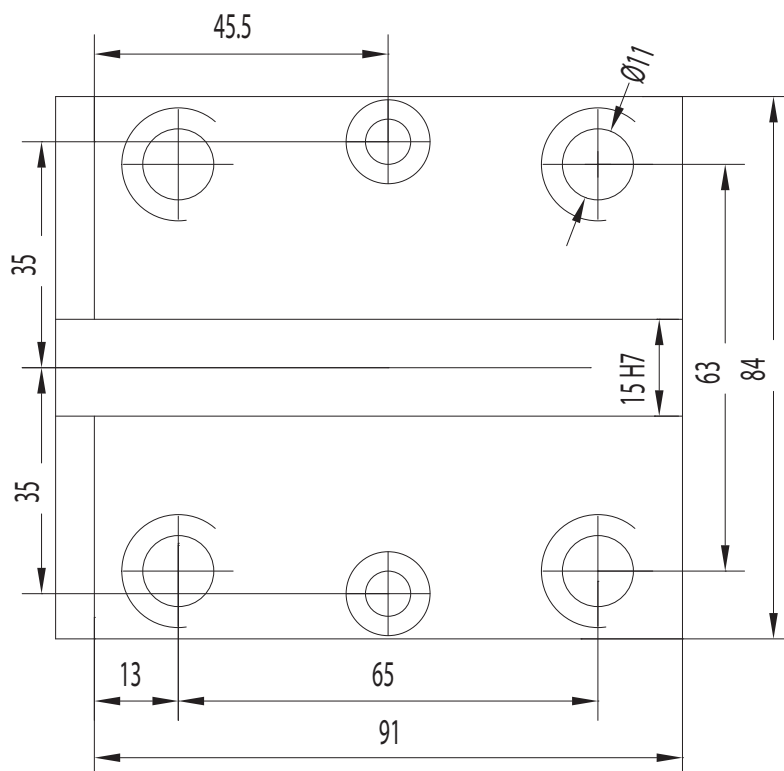

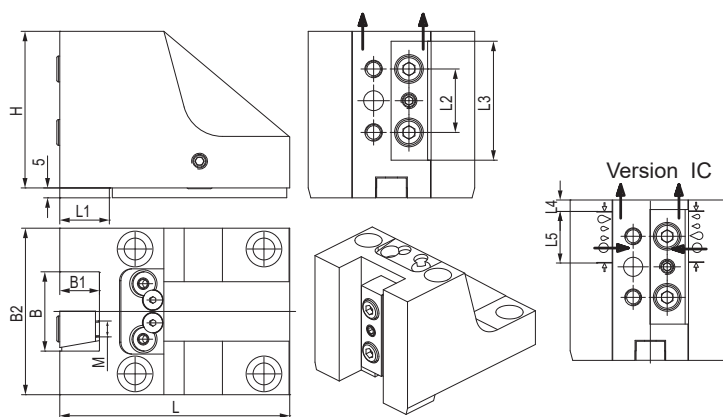

CONNECTION



PORTAUTENSILE RADIALE - RADIAL TOOLHOLDERS

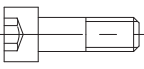

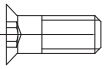
CODE N.	INTERNAL COOLANT	B1	B	B2	L	L1	L2	L3	L4	L5	H	M
128-41524	NO	20	40	84	116	25	32	60	6	27	79	M8
128-41524-IC	YES	20	40	84	116	25	32	60	6	27	79	M8
128-41525	NO	25	50	98	121	30	46	80	8	32	84	M10
128-41525-IC	YES	25	50	98	121	30	46	80	8	32	84	M10

CODE N.	CLAMPING PLATE	KEY	SCREW FOR KEY	COOLANT BALL	SCREW FOR BALL	O RING
128-41524						
128-41524	832-007030	814-203230	811-101016	833-001410	811-108024	823-101015
128-41524-IC	832-007030	814-203230	811-101016	833-001410	811-108024	823-101015
128-41525	832-007540	814-203230	811-101016	833-001410	811-108024	823-101015
128-41525-IC	832-007540	814-203230	811-101016	833-001410	811-108024	823-101015

PORTAUTENSILE RADIALE - RADIAL TOOLHOLDERS

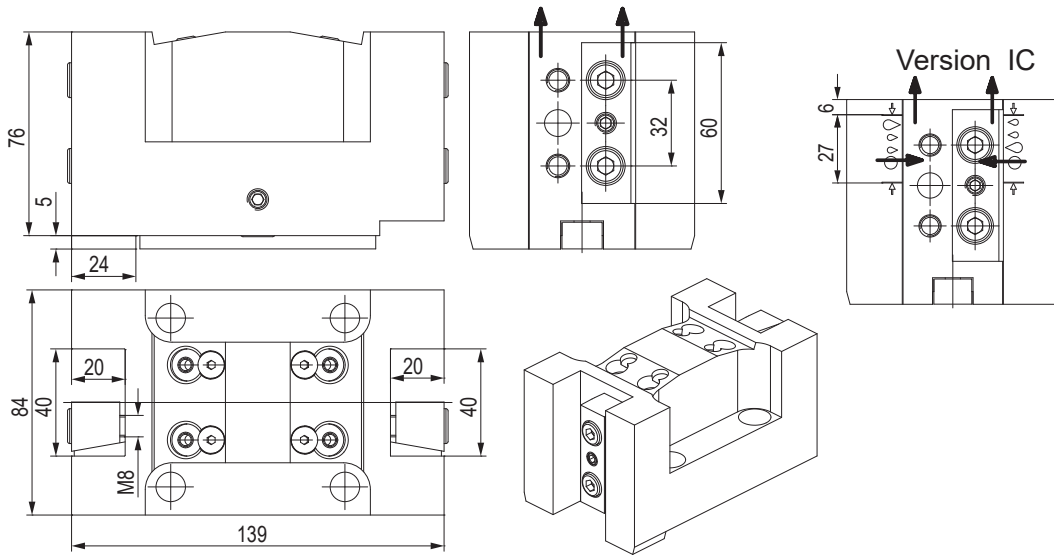

CODE N.	INTERNAL COOLANT	CLAMPING PLATE	KEY	SCREW FOR KEY	COOLANT BALL	SCREW FOR BALL	O RING
128-41527	NO	832-007030	814-203230	811-101016	833-001410	811-108024	823-101015
128-41527-IC	YES	832-007030	814-203230	811-101016	833-001410	811-108024	823-101015



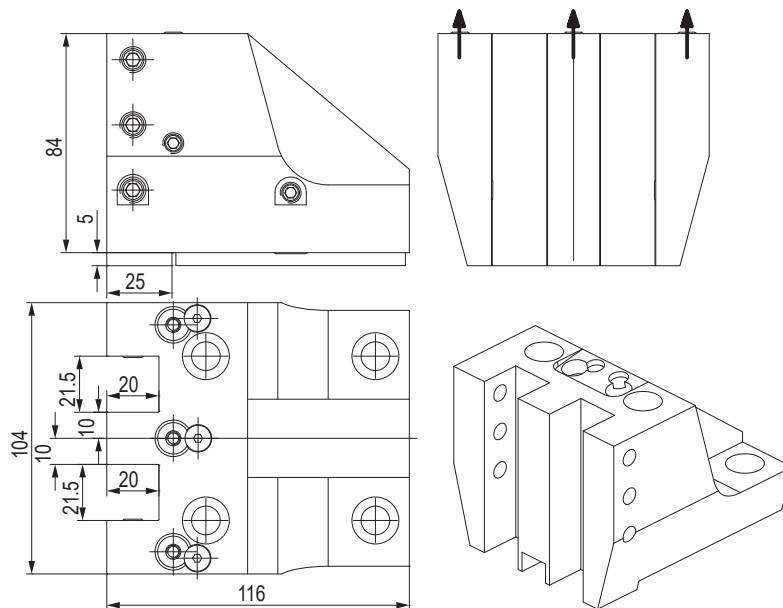



PORTAUTENSILE RADIALE - RADIAL TOOLHOLDERS

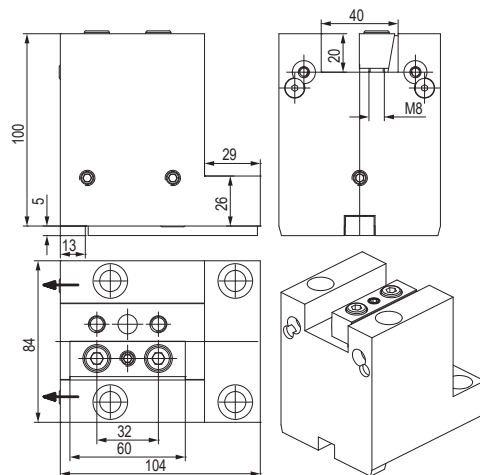

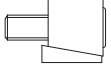
CODE N.	CLAMPING SCREW1 (M10X20)	CLAMPING SCREW2 (M10X16)	KEY	SCREW FOR KEY	COOLANT BALL	SCREW FOR BALL	O RING
128-41526	811-102038	811-102037	814-203230	811-101016	833-001410	811-108024	823-101015

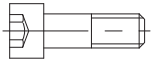
PORTAUTENSILE ASSIALE - AXIAL TOOLHOLDERS

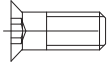





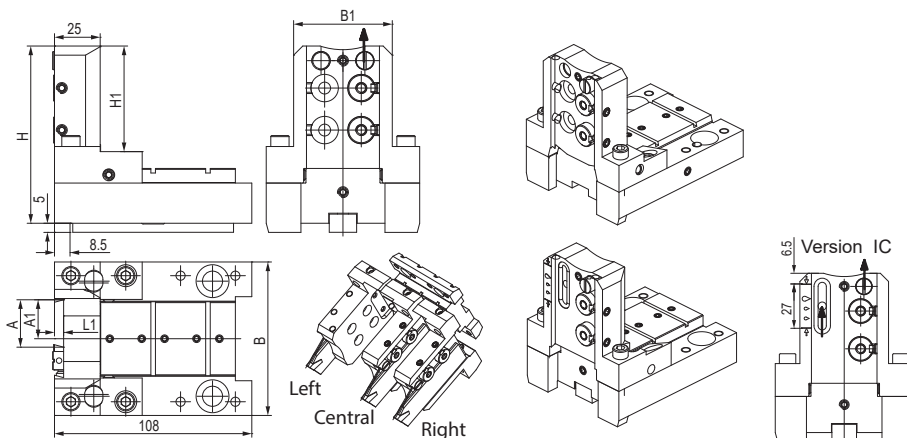

CODE N.	CLAMPING PLATE	KEY	SCREW FOR KEY	COOLANT BALL	SCREW FOR BALL	O RING
128-31515						
128-31515	832-007030	814-203230	811-101016	833-001410	811-108024	823-101015

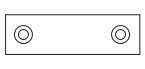
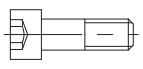
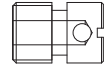
PORTALAMA - CUT-OFF HOLDERS

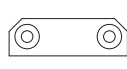
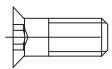

CODE N.	INTERNAL COOLANT	A	A1	L1	B	B1	H	H1
128-11566	NO	26	21.4	5	84	54	97	58
128-11566-IC	YES	26	21.4	5	84	54	97	58
128-11567	NO	32	25	6	94	63	105	66
128-11567-IC	YES	32	25	6	94	63	105	66

CODE N.	KEY	SCREW FOR KEY	COOLANT NOZZLE	O RING FOR COOLANT NOZZLE	O RING FOR INT. COOLANT	O RING FOR BODY	O RING FOR COOLANT INTAKE
							
128-11566	814-203230	811-101015	833-001490	823-101058	-	823-101061	823-101015
128-11566-IC	814-203230	811-101015	833-001490	823-101058	823-201140	823-101061	823-101015
128-11567	814-203230	811-101015	833-001490	823-101058	-	823-101061	823-101015
128-11567-IC	814-203230	811-101015	833-001490	823-101058	823-201140	823-101061	823-101015

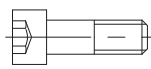
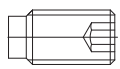
CODE N.	SHIM PLATE	SCREW FOR PLATE	CLAMPING PIN	SPRING	CLAMPING SCREW	SCREW
						
128-11566	832-014448	811-108037	832-014447	824-300012	811-101028	811-104013
128-11566-IC	832-014448	811-108037	832-014447	824-300012	811-101028	811-104013
128-11567	832-014448	811-108037	832-014450	824-300012	811-101029	811-104013
128-11567-IC	832-014448	811-108037	832-014450	824-300012	811-101029	811-104013

PORTAUTENSILE PER BARENI - TOOLHOLDER FOR BORING BAR

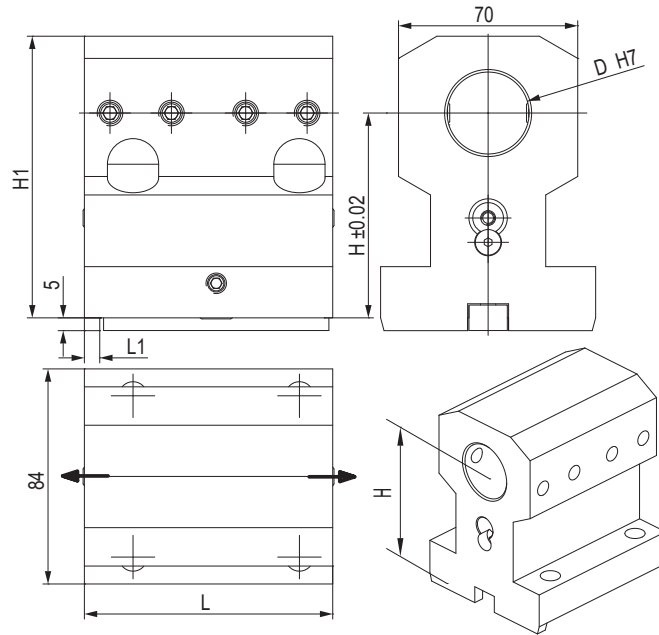

CODE N.	D	H	H1	L	L1	CLAMPING SCREW	KEY	SCREW FOR KEY	COOLANT BALL	SCREW FOR BALL	O RING
128-21538	32	80	110	97	6	811-102038	814-203230	811-101016	833-001410	811-108024	823-101015
128-21540	32	100	130	97	6	811-102038	814-203230	811-101016	833-001410	811-108024	823-101015
128-21548	40	80	110	106	15	811-102037	814-203230	811-101016	833-001410	811-108024	823-101015

PORTAUTENSILE COMBINATO PER BARENI E PUNTE A INSERTI COMBI TOOLHOLDER FOR BORING BAR AND INSERTDRILL

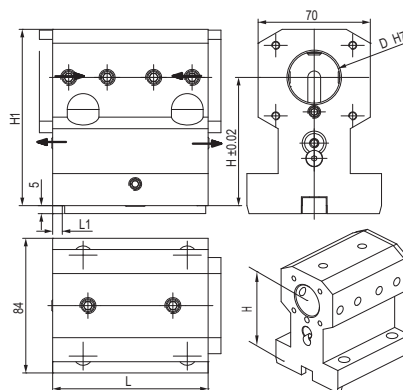

CODE N.	D	H	H1	L	L1	CLAMPING SCREW1 (D32 M10X20) (D40 M10X16)	CLAMPING SCREW2 (D32 M10X16) (D40 M10X12)	KEY	SCREW FOR KEY
128-21539	32	80	110	97	6	811-102038	811-102037	814-203230	811-101016
128-21541	32	100	130	97	6	811-102038	811-102037	814-203230	811-101016
128-21549	40	80	110	106	15	811-102037	811-102036	814-203230	811-101016

CODE N.	COOLANT BALL	SCREW FOR BALL	COVER	SCREW FOR COVER	O RING
128-21539	833-001410	811-108024	832-003363	811-101016	823-101015
128-21541	833-001410	811-108024	832-003363	811-101016	823-101015
128-21549	833-001410	811-108024	832-003363	811-101016	823-101015

PORTAUTENSILE PER BARENI - TOOLHOLDER FOR BORING BAR

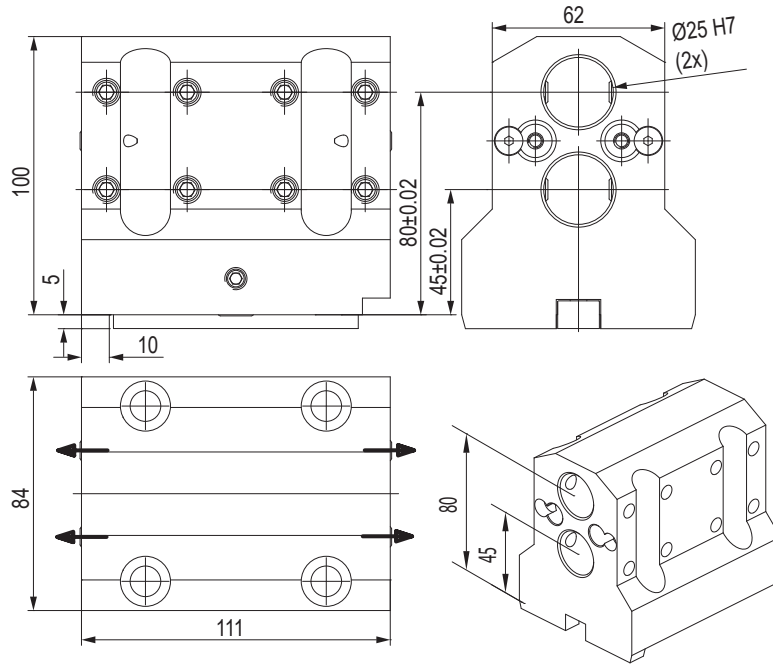

CODE N.	CLAMPING SCREW	KEY	SCREW FOR KEY	COOLANT BALL	SCREW FOR BALL	O RING
128-21542	811-102038	814-203230	811-101016	833-001410	811-108024	823-101015

PORTAUTENSILE CON USCITA POLIGONALE POLIGONAL TOOLHOLDERS

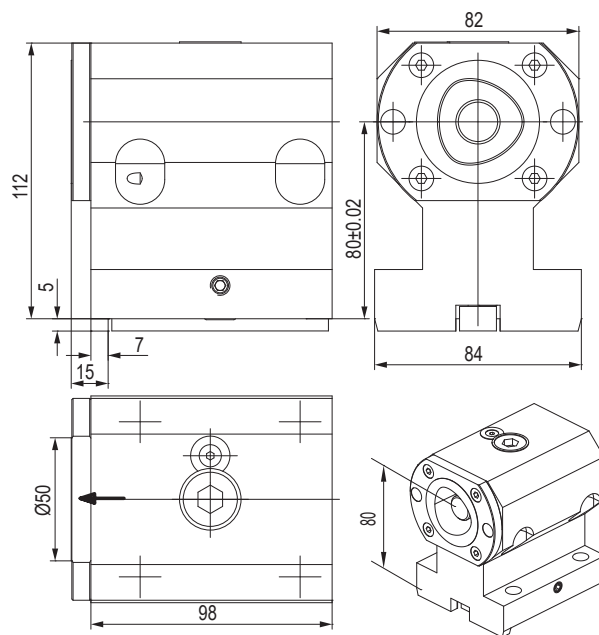

CODE N.	CAPTO	CLAMPING UNIT	KEY	SCREW FOR KEY	O RING
128-11579	C50	CXC50-10	814-203230	811-101016	823-101015

PORTAUTENSILE CON USCITA POLIGONALE POLIGONAL TOOLHOLDERS

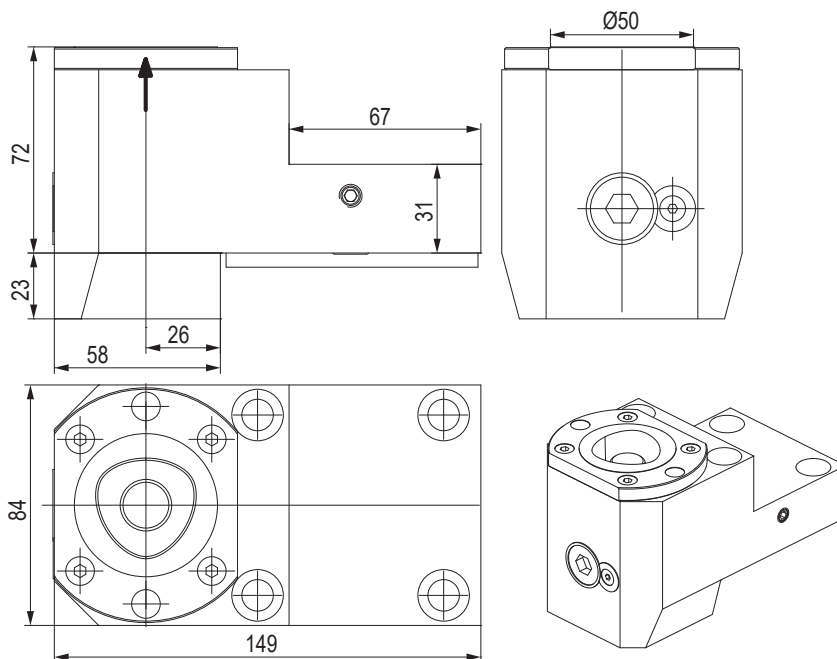

CODE N.	CAPTO	CLAMPING UNIT	KEY	SCREW FOR KEY	O RING
128-11580	C50	CXC50-10	814-203230	811-101016	823-101015

PORTAUTENSILE MOTORIZZATO ASSIALE STRAIGHT DRILLING AND MILLING HEAD

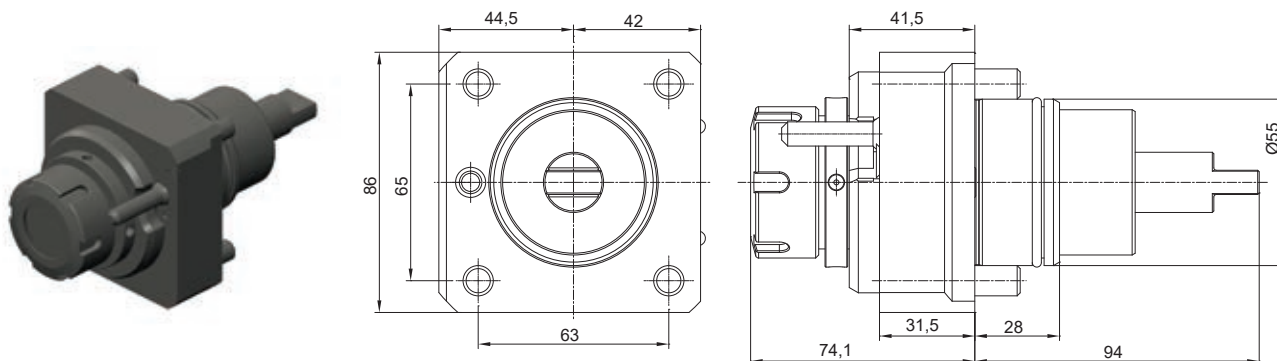

CODE N.	ER	MAX SPEED (Rpm)	I	Max. Torque (Nm)	INTERNAL COOLING	P Bar
124-05521	ER32	6000	1:1	50	no	-
124-05522	ER32	6000	1:1	50	yes	20

PORTAUTENSILE MOTORIZZATO RADIALE ANGULAR DRILLING AND MILLING HEAD

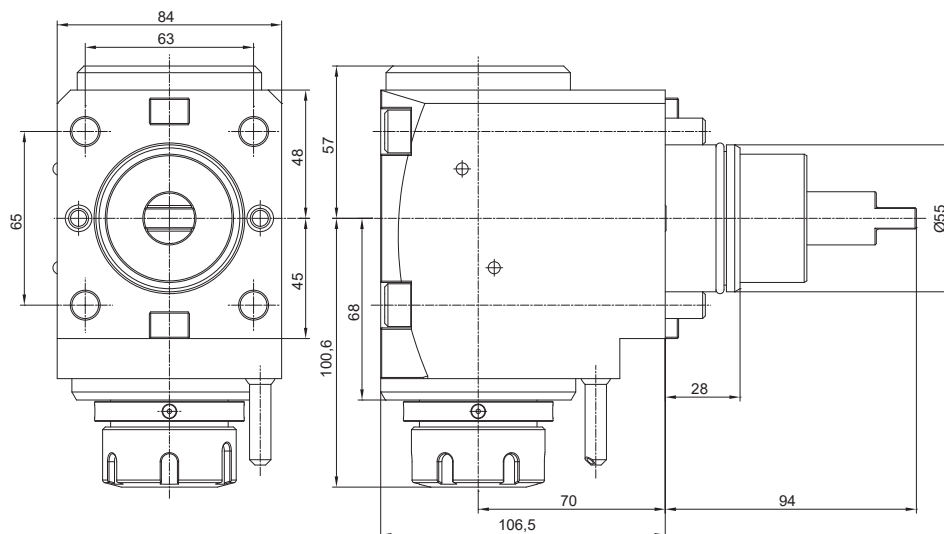

CODE N.	ER	MAX SPEED (Rpm)	l	Max. Torque (Nm)	INTERNAL COOLING	P Bar
124-05523	ER32	6000	1:1	50	no	-
124-05524	ER32	6000	1:1	50	yes	20

BARRA DI CONTROLLO - CONTROL PIN

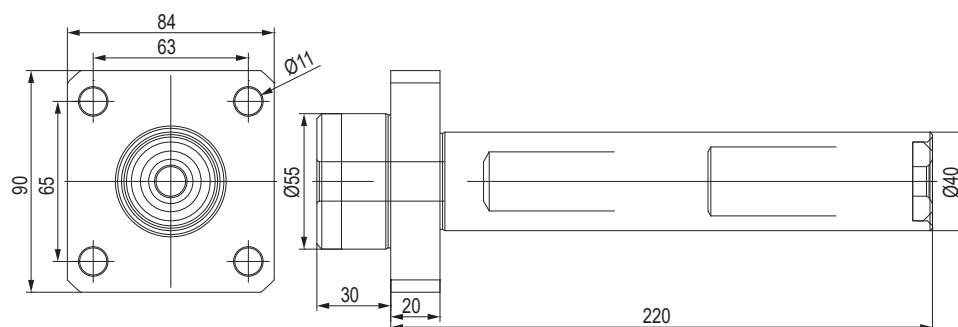
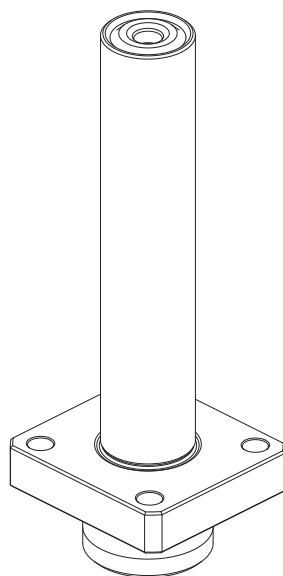

CODE N.

137-00209

TAPPO DI PROTEZIONE - PROTECTION COVER

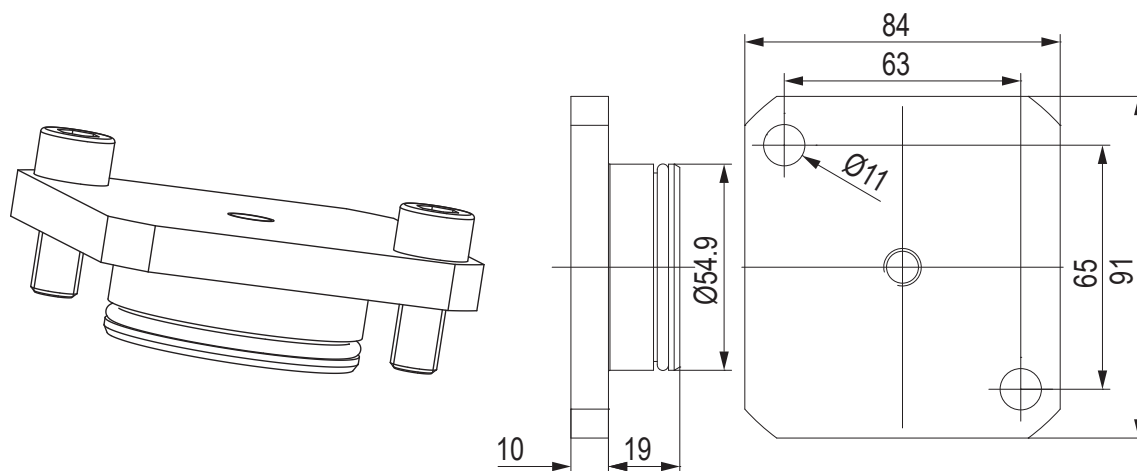

CODE N.

O RING



137-00244

823-101064

BUSSOLA PER PORTABARENI DRILL SOCKET FOR TOOLHOLDER

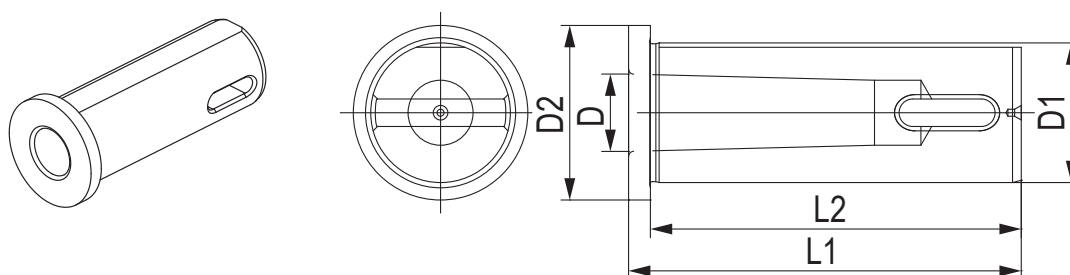

CODE N.	Ø	MORSE	D	D1	D2	L1	L2
114-33208	32	1	12,065	32	40	90	85
114-33209	32	2	17,780	32	40	90	85
114-34008	40	2	17,780	40	50	110	105
114-34009	40	3	23,825	40	50	110	105

BUSSOLA PER PORTABARENI BORING BAR SLEEVE FOR TOOLHOLDER

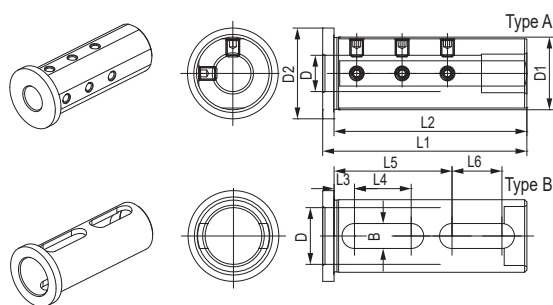

CODE N.	D1	D	D2	L1	L2	L3	L4	L5	L6	B	TYPE	SCREW
115-63260	32	8	40	90	85	-	-	-	-	-	A	811-10219
115-63261	32	10	40	90	85	-	-	-	-	-	A	811-10219
115-63211	32	12	40	90	85	-	-	-	-	-	A	811-10218
115-63212	32	16	40	90	85	-	-	-	-	-	A	811-10218
115-63213	32	20	40	90	85	-	-	-	-	-	A	811-10217
115-63214	32	25	40	90	85	9	25	52	22	11	B	-
115-64043	40	8	50	110	105	-	-	-	-	-	A	811-10221
115-64044	40	10	50	110	105	-	-	-	-	-	A	811-10220
115-64045	40	12	50	110	105	-	-	-	-	-	A	811-10220
115-64046	40	16	50	110	105	-	-	-	-	-	A	811-10228
115-64047	40	20	50	110	105	-	-	-	-	-	A	811-10227
115-64048	40	25	50	110	105	-	-	-	-	-	A	811-10226
115-64049	40	32	50	110	105	10	35	65	28	13	B	-

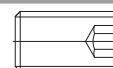

BUSSOLA PER PORTABARENI BORING BAR SLEEVE FOR TOOLHOLDER

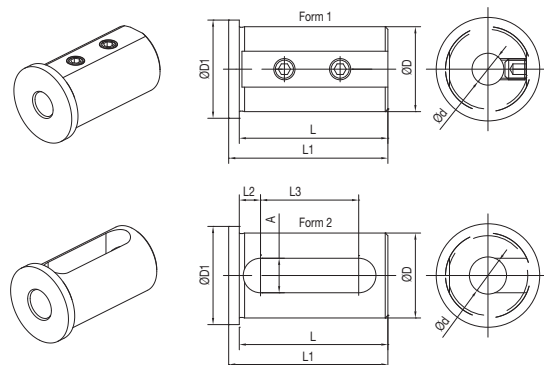

CODE N.	D	d	FORM	L	L1	L2	L3	A	D1
165-63352	32	8	1	56	60	-	-	-	37
165-63353	32	10	1	56	60	-	-	-	37
165-63354	32	12	1	56	60	-	-	-	37
165-63356	32	16	2	56	60	8	37	13	37
165-63358	32	20	2	56	60	8	37	13	37
165-63359	32	25	2	56	60	8	37	13	37
165-64247	40	8	1	71	75	-	-	-	45
165-64248	40	10	1	71	75	-	-	-	45
165-64249	40	12	1	71	75	-	-	-	45
165-64251	40	16	2	71	75	8	52	13	45
165-64253	40	20	2	71	75	8	52	13	45
165-64254	40	25	2	71	75	8	52	13	45
165-64255	40	32	2	71	75	8	52	13	45

BUSSOLA PER PORTABARENI BORING BAR SLEEVE FOR TOOLHOLDER

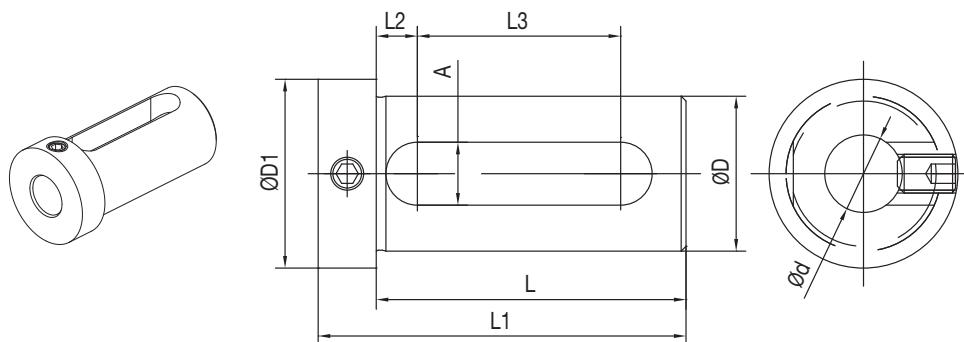

CODE N.	D	d	L	L1	L2	L3	A	D1	SCREW
165-63347	32	16	64	76	8,5	42	13	39	811-102028
165-63349	32	20	64	76	8,5	42	13	39	811-102027
165-63350	32	25	64	76	8,5	42	13	39	811-102027
165-64241	40	16	74	88	9	51	14	48	811-102038
165-64243	40	20	74	88	9	51	14	48	811-102038
165-64244	40	25	74	88	9	51	14	48	811-102037
165-64245	40	32	74	88	9	51	14	48	811-102037



BUSSOLA PER PORTABARENI BORING BAR SLEEVE FOR TOOLHOLDER

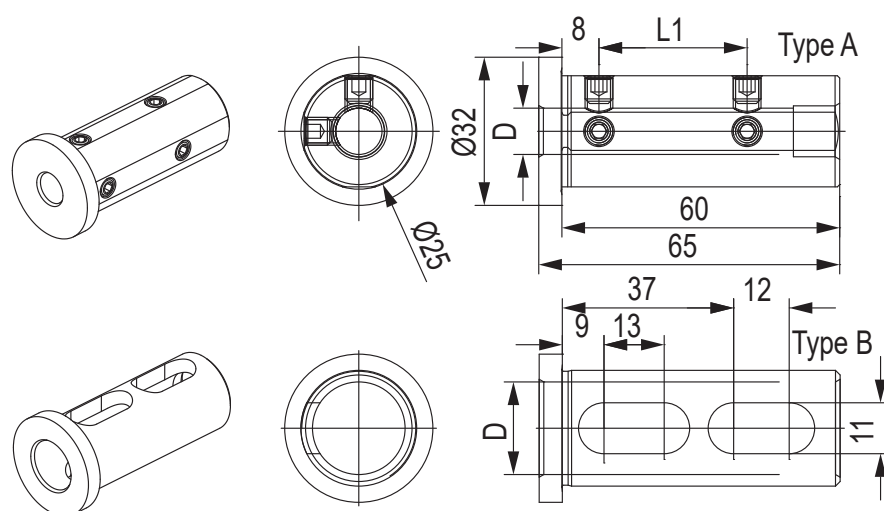

CODE N.	Ø	D	L1	TYPE	SCREW
115-62573	25	6	22	A	811-102011
115-62538	25	8	27	A	811-102018
115-62539	25	10	32	A	811-102017
115-62540	25	12	32	A	811-102017
115-62541	25	16	-	B	-

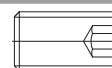

CMZ TL15T/M/TM/S/MS
TB46/67 M/CM

MIYANO ABX 51/64 THY / SY Y

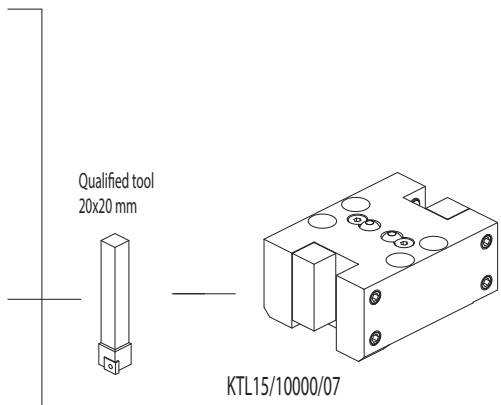
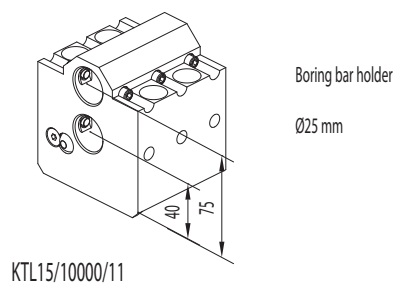
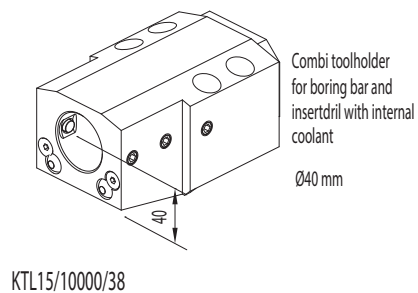
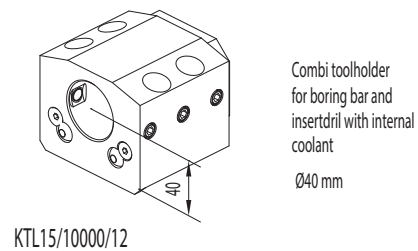
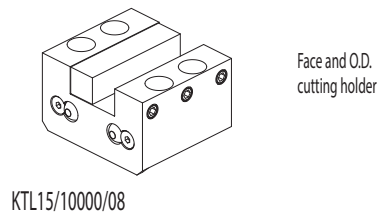
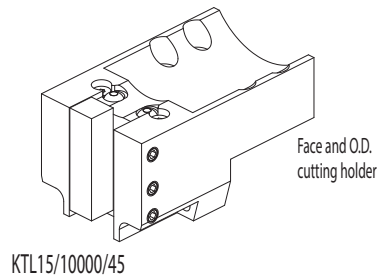
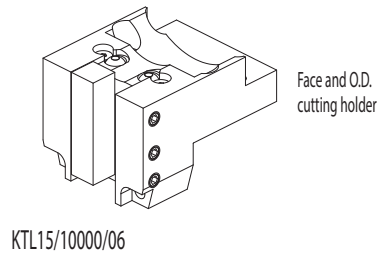

ACCESSORIES

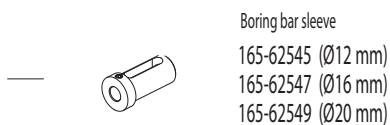
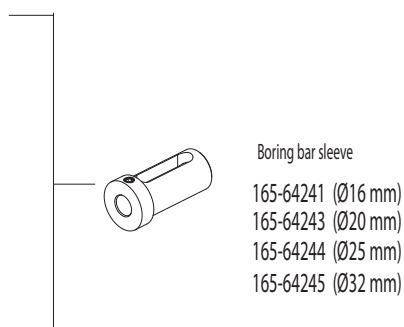

CONNECTION

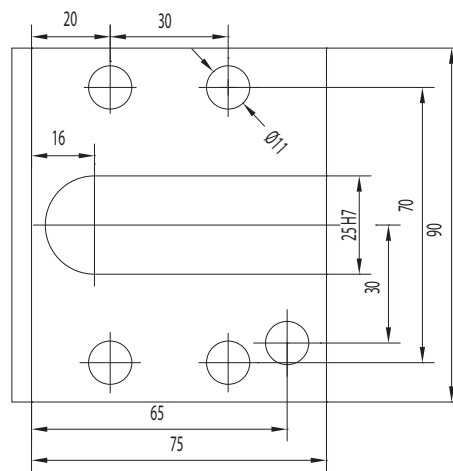

CONNECTION

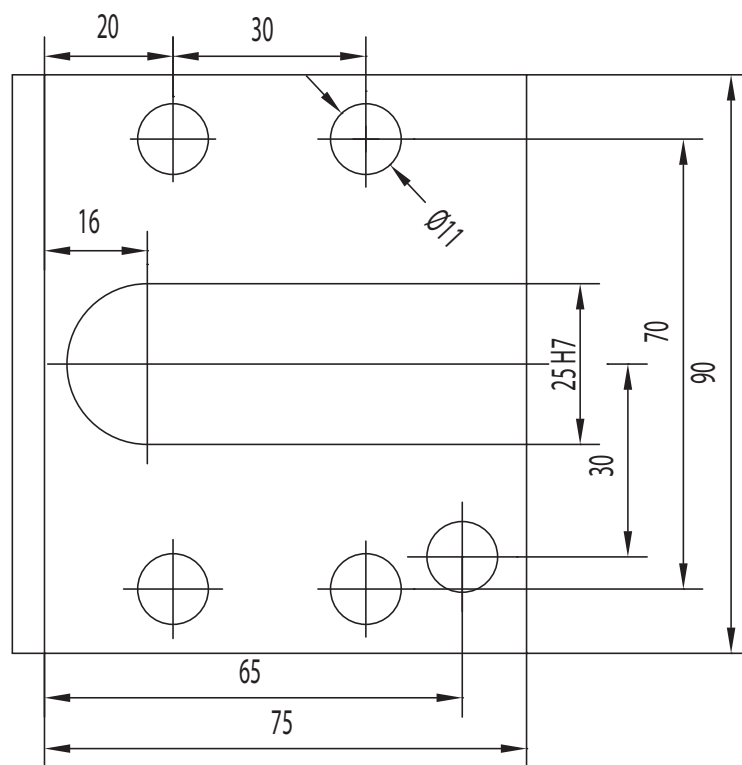

PORTAUTENSILE RADIALE - RADIAL TOOLHOLDERS

12

KINTEK®

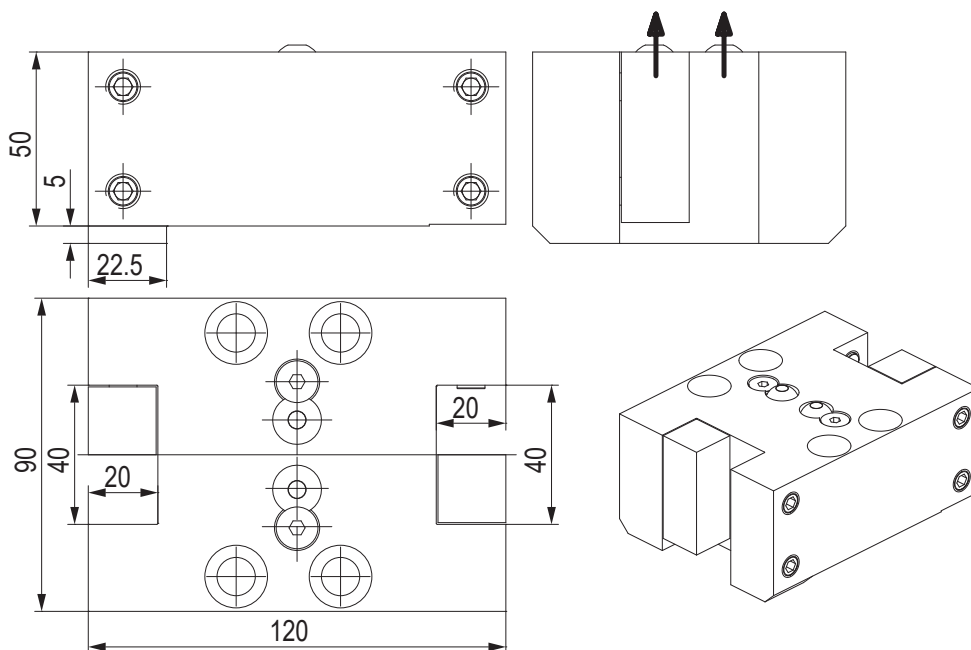

CODE N.	CLAMPING SCREW	CLAMPING PLATE	COOLANT BALL	SCREW FOR COOLANT BALL
KTL15/10000/07				
	811-104030	832-002222	833-001470	811-108018

PORTAUTENSILE RADIALE - RADIAL TOOLHOLDERS

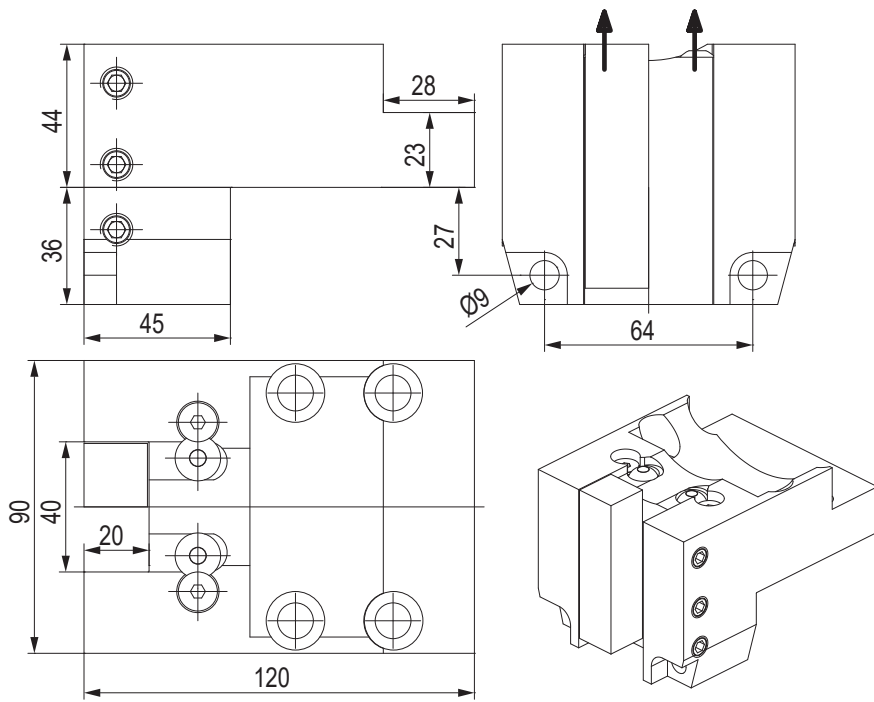

CODE N.	CLAMPING SCREW	CLAMPING PLATE	COOLANT BALL	SCREW FOR COOLANT BALL
KTL15/10000/06	811-104030	832-002223	833-001470	811-108018

PORTAUTENSILE RADIALE - RADIAL TOOLHOLDERS

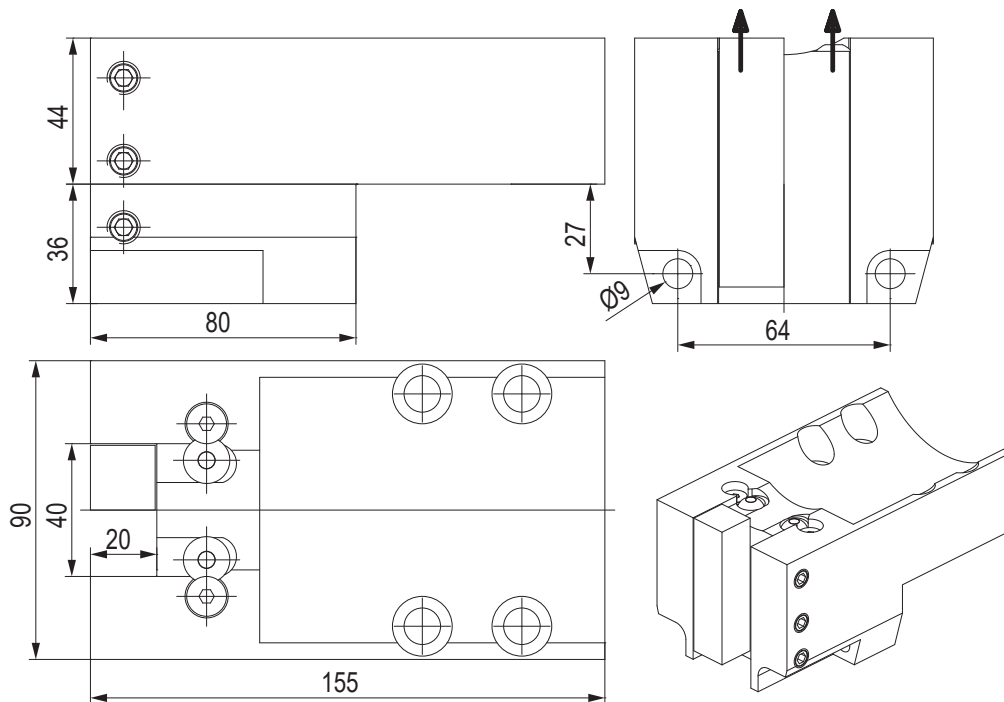

CODE N.	CLAMPING SCREW	CLAMPING PLATE	COOLANT BALL	SCREW FOR COOLANT BALL
KTL15/10000/45	811-104030	832-002223	833-001470	811-108018

PORTAUTENSILE ASSIALE - AXIAL TOOLHOLDERS

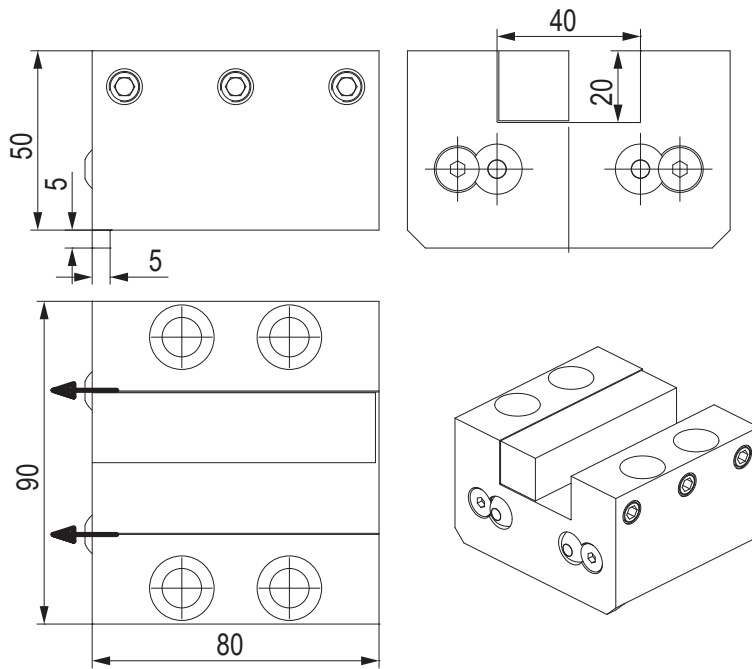

CODE N.	CLAMPING SCREW	CLAMPING PLATE	COOLANT BALL	SCREW FOR COOLANT BALL
KTL15/10000/08	811-104030	832-002223	833-001470	811-108018

PORTAUTENSILE COMBINATO PER BARENI E PUNTE A INSERTI COMBI TOOLHOLDER FOR BORING BAR AND INSERTDRILL

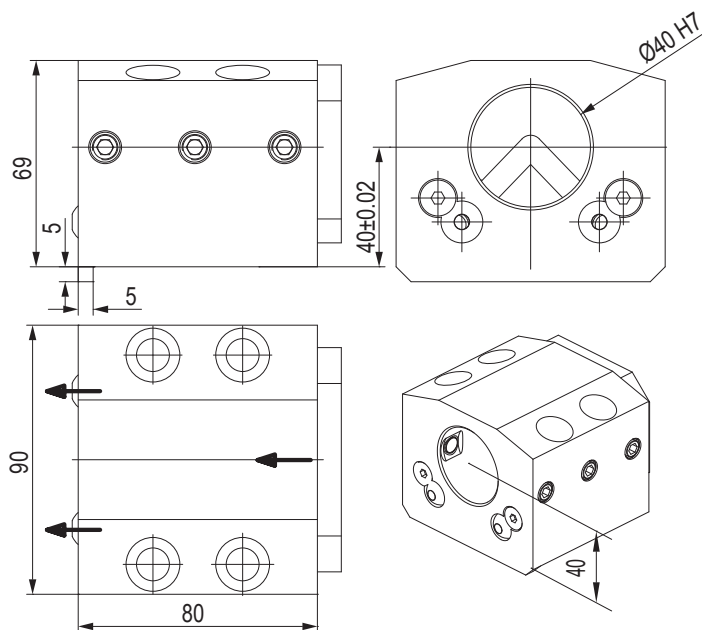

CODE N.	CLAMPING SCREW	COVER	SCREW FOR COVER	COOLANT BALL	SCREW FOR COOLANT BALL
KTL15/10000/12	811-104030	832-003063	811-101016	833-001470	811-108018

PORTAUTENSILE COMBINATO PER BARENI E PUNTE A INSERTI COMBI TOOLHOLDER FOR BORING BAR AND INSERTDRILL

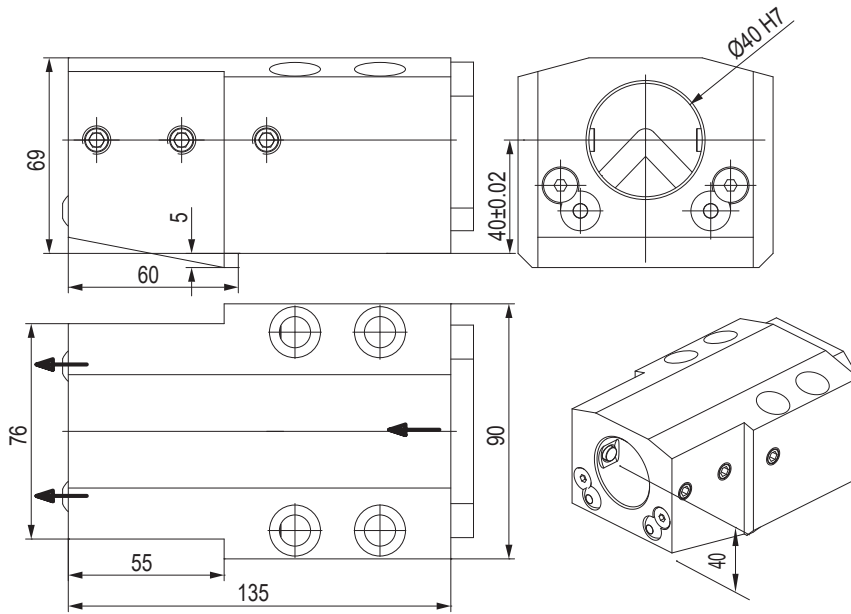

CODE N.	CLAMPING SCREW1 (M10X20)	CLAMPING SCREW2 (M10X25)	COVER	SCREW FOR COVER	COOLANT BALL	SCREW FOR COOLANT BALL
KTL15/10000/38	811-104029	811-104030	832-003063	811-101016	833-001470	811-108018

BUSSOLA PER PORTABARENI BORING BAR SLEEVE FOR TOOLHOLDER

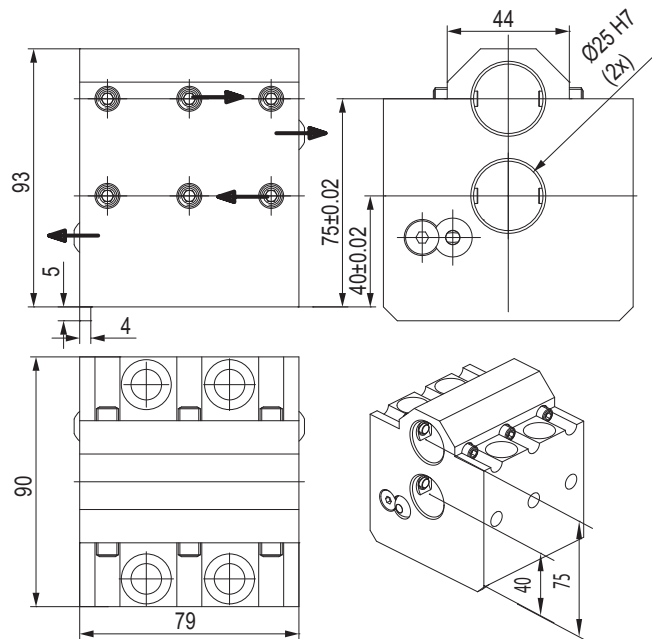

CODE N.	CLAMPING SCREW	COOLANT BALL	SCREW FOR COOLANT BALL
KTL15/10000/11	811-104021	833-001470	811-108018

BUSSOLA PER PORTABARENI BORING BAR SLEEVE FOR TOOLHOLDER

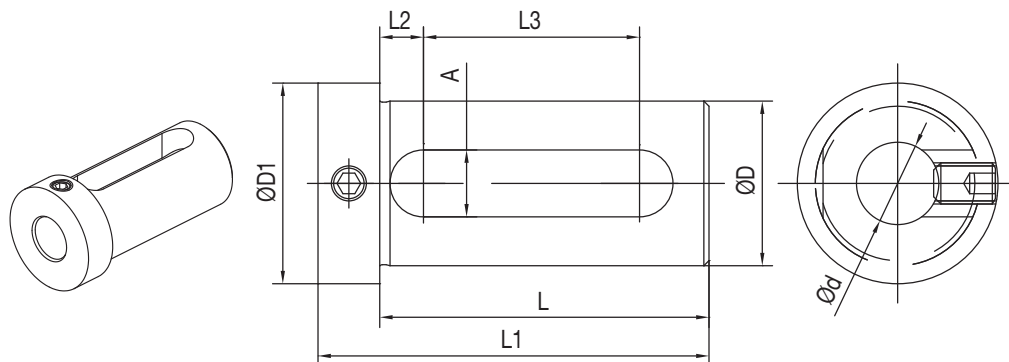

CODE N.	D	d	L	L1	L2	L3	A	D1
165-62545	25	12	54	66	8,5	32	13	32
165-62547	25	16	54	66	8,5	32	13	32
165-62549	25	20	54	66	8,5	32	13	32
165-64241	40	16	74	88	9	51	14	48
165-64243	40	20	74	88	9	51	14	48
165-64244	40	25	74	88	9	51	14	48
165-64245	40	32	74	88	9	51	14	48

KINTEK[®]
sponsor

WORLD SUPERBIKE
2021



DUCATI

PORSCHE MOBIL 1
SUPERCUP
2021

PORSCHE



DMG MORI
(VDI30)

CTX310/410 V4/V6 - CTX 320 V4/V6
 CTX420 V4/V6 (option) - CTX Alpha 300 V4
 CTX Alpha 500 V4/V6
 CTX Beta 500/800/1250 V4/V6 (option)
 TWIN 42/65/102
 SPRINT 65/50

RADIAL TURRET

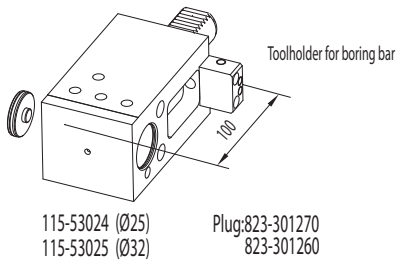
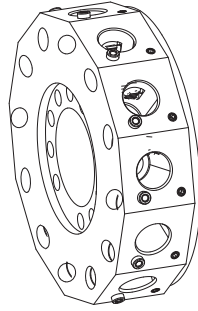

Toolholder for boring bar

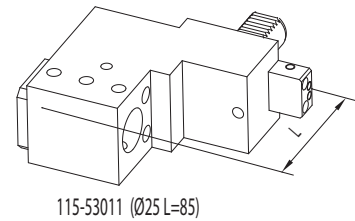

Toolholder for boring bar

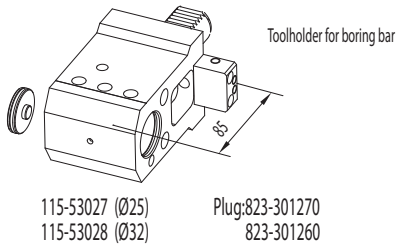

Boring bar sleeve

- 165-62551 (Ø25/Ø8)
- 165-62552 (Ø25/Ø10)
- 165-62553 (Ø25/Ø12)

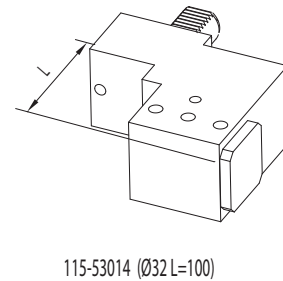

Boring bar sleeve

- 165-62555 (Ø25/Ø16)
- 165-62557 (Ø25/Ø20)

- 165-63352 (Ø32/Ø8)
- 165-63353 (Ø32/Ø10)
- 165-63354 (Ø32/Ø12)

Boring bar sleeve

- 165-62545 (Ø25/Ø12)
- 165-62547 (Ø25/Ø16)
- 165-62549 (Ø25/Ø20)

- 165-63347 (Ø32/Ø16)
- 165-63349 (Ø32/Ø20)
- 165-63350 (Ø32/Ø25)

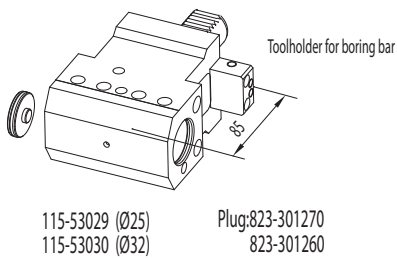

PORTAUTENSILE PER BARENI - TOOLHOLDER FOR BORING BAR

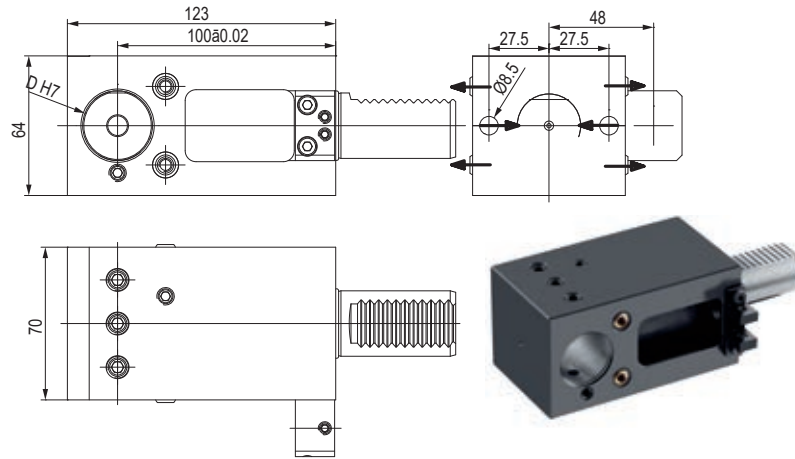

CODE N.	D	CLAMPING SCREW	COOLANT PLUG	SEEGER RING FOR COOLANT PLUG	O RING FOR COOLANT PLUG	COOLANT NOZZLE
115-53024	25	811-102030	823-301270	822-10209	823-101031	833-001110
115-53025	32	811-102037	823-301260	822-10208	823-101017	833-001110

CODE N.	STOP NUT	INSERT FOR STOP NUT	SCREW FOR STOP NUT	SCREW FOR STOP NUT (M6x6)	SCREW FOR STOP NUT (M6x8)	O RING FOR VDI30
115-53024	832-003301	832-003302	811-101021	811-102017	811-102018	823-101017
115-53025	832-003301	832-003302	811-101021	811-102017	811-102018	823-101017

PORTAUTENSILE PER BARENI - TOOLHOLDER FOR BORING BAR

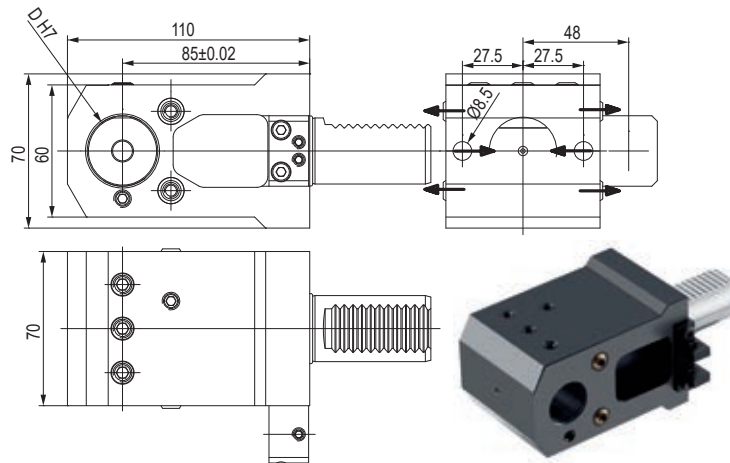

CODE N.	D	CLAMPING SCREW	COOLANT PLUG	SEEGER RING FOR COOLANT PLUG	O RING FOR COOLANT PLUG	COOLANT NOZZLE
115-53027	25	811-102029	823-301270	822-10209	823-101031	833-001110
115-53028	32	811-102037	823-301260	822-10208	823-101017	833-001110

CODE N.	STOP NUT	INSERT FOR STOP NUT	SCREW FOR STOP NUT	SCREW FOR STOP NUT (M6x6)	SCREW FOR STOP NUT (M6x8)	O RING FOR VDI30
115-53027	832-003301	832-003302	811-101021	811-102017	811-102018	823-101017
115-53028	832-003301	832-003302	811-101021	811-102017	811-102018	823-101017

PORTAUTENSILE PER BARENI - TOOLHOLDER FOR BORING BAR

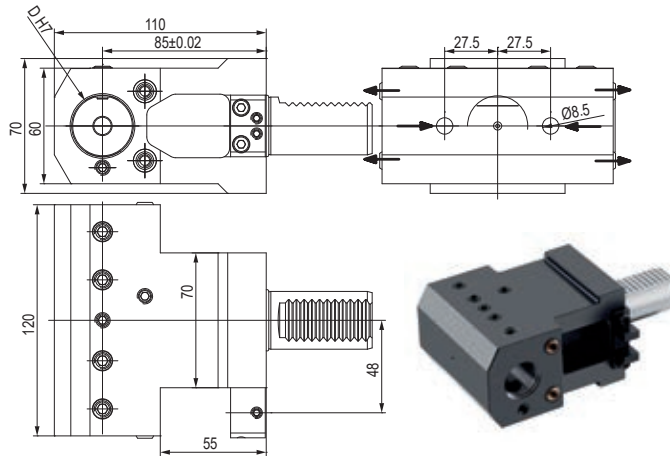

CODE N.	D	CLAMPING SCREW1	CLAMPING SCREW2	COOLANT PLUG	SEGER RING FOR COOLANT PLUG	O RING FOR COOLANT PLUG	COOLANT NOZZLE
115-53029	25	811-102029	811-104021	823-301270	822-10209	823-101031	833-001110
115-53030	32	811-102037	811-104021	823-301260	822-10208	823-101017	833-001110

CODE N.	STOP NUT	INSERT FOR STOP NUT	SCREW FOR STOP NUT	SCREW FOR STOP NUT (M6x6)	SCREW FOR STOP NUT (M6x8)	O RING FOR VDI30
115-53029	832-003301	832-003302	811-101021	811-102017	811-102018	823-101017
115-53030	832-003301	832-003302	811-101021	811-102017	811-102018	823-101017

PORTAUTENSILE PER BARENI - TOOLHOLDER FOR BORING BAR

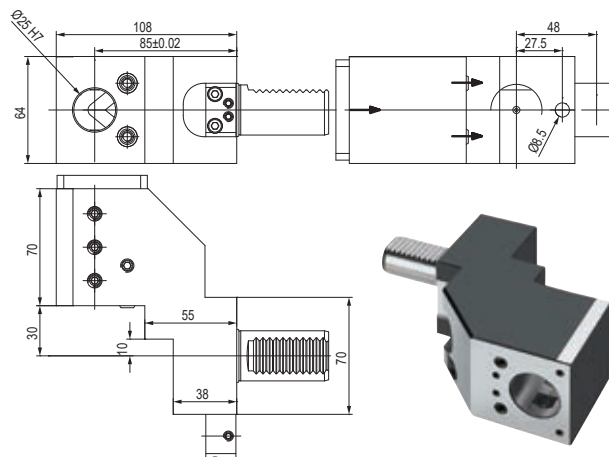

CODE N.	CLAMPING SCREW	COVER FOR INTERNAL COOLANT	SCREW FOR COVER	COOLANT NOZZLE
115-53011	811-102030	832-003304	811-101016	833-001110

CODE N.	STOP NUT	INSERT FOR STOP NUT	SCREW FOR STOP NUT	SCREW FOR STOP NUT (M6x6)	SCREW FOR STOP NUT (M6x8)	O RING FOR VDI30
115-53011	832-003301	832-003302	811-101021	811-102017	811-102018	823-101017

PORTAUTENSILE PER BARENI - TOOLHOLDER FOR BORING BAR

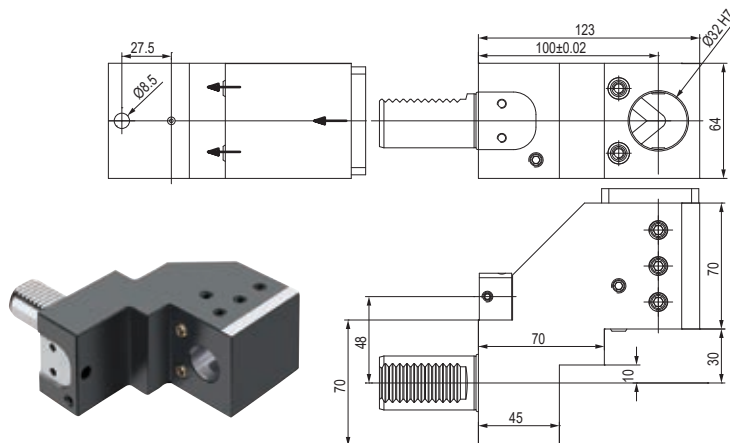

CODE N.	CLAMPING SCREW	COVER FOR INTERNAL COOLANT	SCREW FOR COVER	COOLANT NOZZLE
115-53014	811-102037	832-003304	811-101016	833-001110

CODE N.	STOP NUT	INSERT FOR STOP NUT	SCREW FOR STOP NUT	SCREW FOR STOP NUT (M6x6)	SCREW FOR STOP NUT (M6x8)	O RING FOR VDI30
115-53014	832-003301	832-003302	811-101021	811-102017	811-102018	823-101017

BUSSOLA PER PORTABARENI BORING BAR SLEEVE FOR TOOLHOLDER

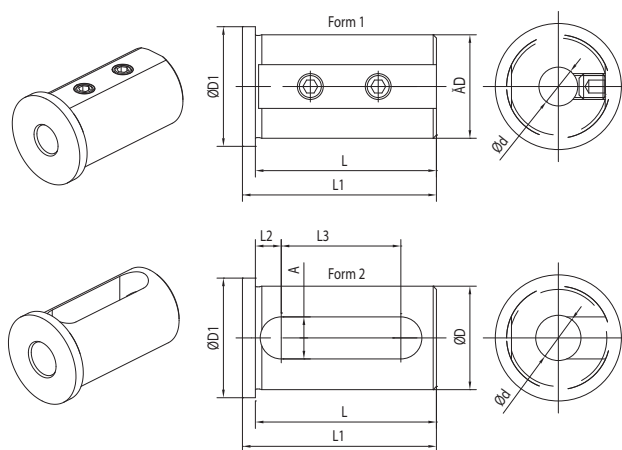

CODE N.	D	d	FORM	L	L1	L2	L3	A	D1
165-62551	25	8	1	46	50	-	-	-	30
165-62552	25	10	1	46	50	-	-	-	30
165-62553	25	12	1	46	50	-	-	-	30
165-62555	25	16	2	46	50	8	27	13	30
165-62557	25	20	2	46	50	8	27	13	30
165-63352	32	8	1	56	60	-	-	-	37
165-63353	32	10	1	56	60	-	-	-	37
165-63354	32	12	1	56	60	-	-	-	37
165-63356	32	16	2	56	60	8	37	13	37
165-63358	32	20	2	56	60	8	37	13	37
165-63359	32	25	2	56	60	8	37	13	37

BUSSOLA PER PORTABARENI BORING BAR SLEEVE FOR TOOLHOLDER

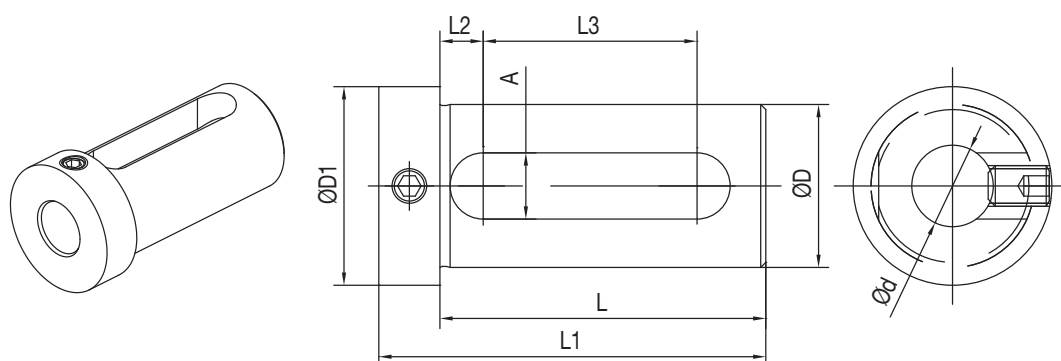

CODE N.	D	d	L	L1	L2	L3	A	D1
165-62545	25	12	54	66	8,5	32	13	32
165-62547	25	16	54	66	8,5	32	13	32
165-62549	25	20	54	66	8,5	32	13	32
165-63347	32	16	64	76	8,5	42	13	39
165-63349	32	20	64	76	8,5	42	13	39
165-63350	32	25	64	76	8,5	42	13	39

12

KINTEK®



DMG MORI
(VDI40)

CTX410 V4/V6 (option)
CTX420 V4/V6
CTXBeta 500/800/1250 V4/V6
TWIN42/65/102 RG2
GMX250/300/400/500
SPRINT65 (option)

RADIAL TURRET

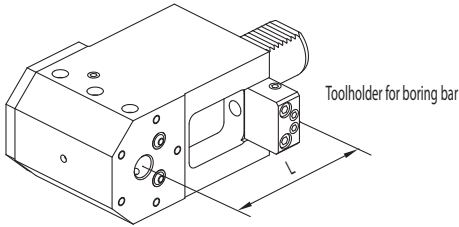

115-54076 (Ø16 L=120)
115-54077 (Ø20 L=120)

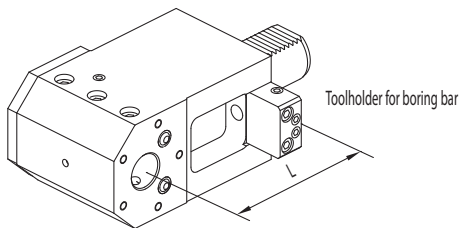

115-54130 (Ø25 L=100)

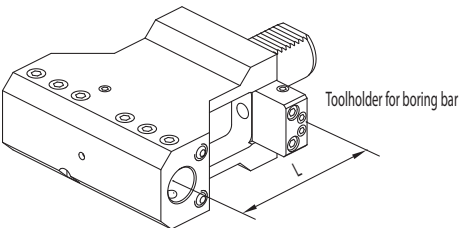

115-54133 (Ø25 L=100)

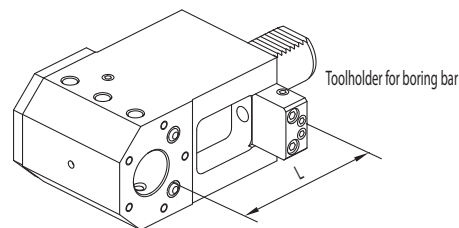

115-54131 (Ø32 L=100)
115-54078 (Ø25 L=120)
115-54079 (Ø32 L=120)

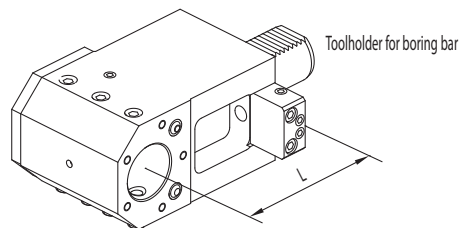

115-54132 (Ø40 L=100)
115-54080 (Ø40 L=120)

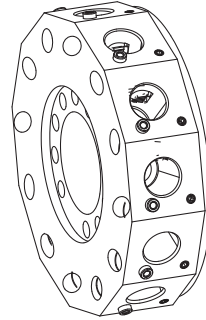

ACCESSORIES

Boring bar sleeve



165-62551 (Ø25/Ø8)
165-62552 (Ø25/Ø10)
165-62553 (Ø25/Ø12)

165-62555 (Ø25/Ø16)
165-62557 (Ø25/Å20)

165-63352 (Ø32/Ø8)
165-63353 (Ø32/Ø10)
165-63354 (Ø32/Ø12)

165-63356 (Ø32/Ø16)
165-63358 (Ø32/Ø20)
165-63359 (Ø32/Ø25)

165-64247 (Ø40/Ø8)
165-64248 (Ø40/Ø10)
165-64249 (Ø40/Ø12)

165-64251 (Ø40/Ø16)
165-64253 (Ø40/Ø20)
165-64254 (Ø40/Ø25)
165-64255 (Ø40/Ø32)

Boring bar sleeve

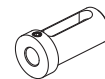

115-62044 (Ø20/Ø8)
115-62045 (Ø20/Ø10)
115-62046 (Ø20/Ø12)

165-62545 (Ø25/Ø12)
165-62547 (Ø25/Ø16)
165-62549 (Ø25/Ø20)

165-63347 (Ø32/Ø16)
165-63349 (Ø32/Ø20)
165-63350 (Ø32/Ø25)

165-64241 (Ø40/Ø16)
165-64243 (Ø40/Ø20)
165-64244 (Ø40/Ø25)
165-64245 (Ø40/Ø32)

Double toolholder for boring bar

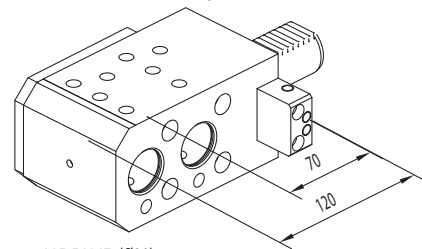

115-54147 (Ø32)

PORTAUTENSILE PER BARENI - TOOLHOLDER FOR BORING BAR

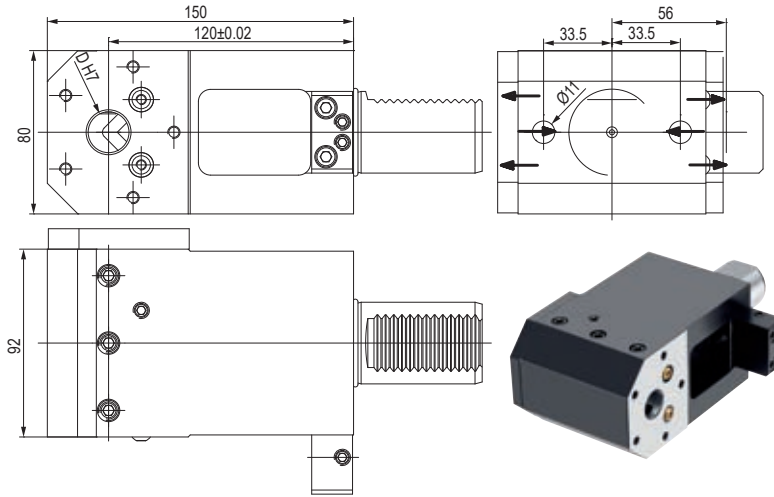

CODE N.	D	CLAMPING SCREW1 (M10X25)	CLAMPING SCREW2 (M8X20)	COVER FOR INTERNAL COOLANT	SCREW FOR COVER	COOLANT NOZZLE
115-54076	16					
115-54077	20	811-102039	811-102030	832-003236	811-101027	833-001080

CODE N.	STOP NUT	INSERT FOR STOP NUT	SCREW FOR STOP NUT	SCREW FOR STOP NUT	O RING FOR VDI40
115-54076					
115-54077	832-003237	832-003238	811-101032	811-102027	823-101036

PORTAUTENSILE PER BARENI - TOOLHOLDER FOR BORING BAR

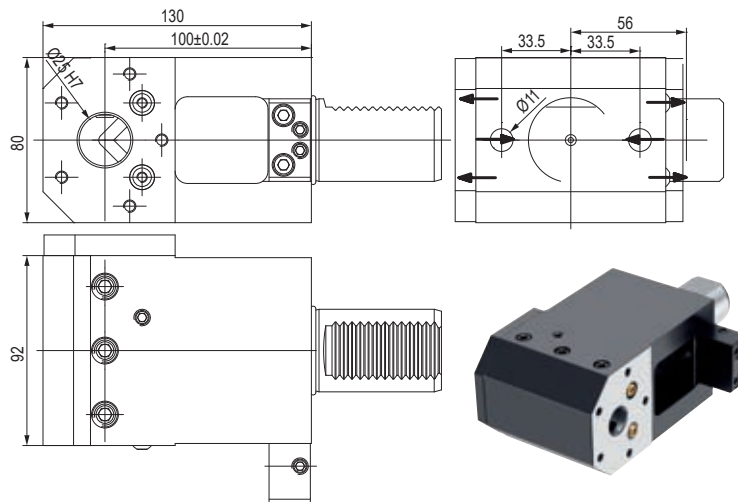

CODE N.	CLAMPING SCREW1 (M12X25)	CLAMPING SCREW2 (M10X25)	COVER FOR INTERNAL COOLANT	SCREW FOR COVER	COOLANT NOZZLE
115-54130					
115-54130	811-102045	811-102039	832-003303	811-101027	833-001080

CODE N.	STOP NUT	INSERT FOR STOP NUT	SCREW FOR STOP NUT	SCREW FOR STOP NUT	O RING FOR VDI40
115-54130					
115-54130	832-003237	832-003238	811-101032	811-102027	823-101036

PORTAUTENSILE PER BARENI - TOOLHOLDER FOR BORING BAR

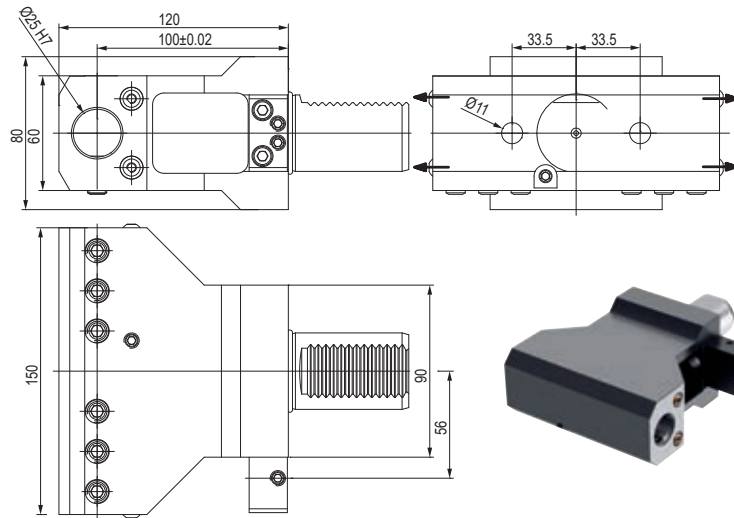

CODE N.	CLAMPING SCREW1 (M12X16)	CLAMPING SCREW2 (M10X20)	COOLANT NOZZLE
115-54133	811-102043	811-102038	833-001080

CODE N.	STOP NUT	INSERT FOR STOP NUT	SCREW FOR STOP NUT	SCREW FOR STOP NUT	O RING FOR VDI40
115-54133	832-003237	832-003238	811-101032	811-102027	823-101036

PORTAUTENSILE PER BARENI - TOOLHOLDER FOR BORING BAR

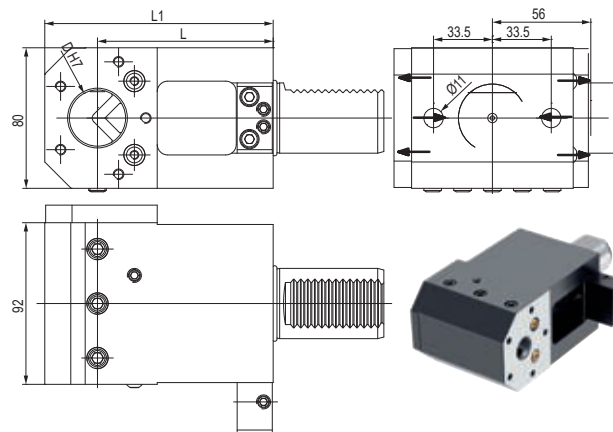

CODE N.	D	L	L1	CLAMPING SCREW1 (M12)	CLAMPING SCREW2 (M10X25)	COVER FOR INTERNAL COOLANT	SCREW FOR COVER
115-54131	32	100	130	811-102044	811-102039	832-003303	811-101027
115-54078	25	120	150	811-102045	811-102039	832-003236	811-101027
115-54079	32	120	150	811-102044	811-102039	832-003236	811-101027

CODE N.	STOP NUT	INSERT FOR STOP NUT	SCREW FOR STOP NUT	SCREW FOR STOP NUT	O RING FOR VDI40	COOLANT NOZZLE
115-54131	832-003237	832-003238	811-101032	811-102027	823-101036	833-001080
115-54078	832-003237	832-003238	811-101032	811-102027	823-101036	833-001080
115-54079	832-003237	832-003238	811-101032	811-102027	823-101036	833-001080

PORTAUTENSILE PER BARENI - TOOLHOLDER FOR BORING BAR

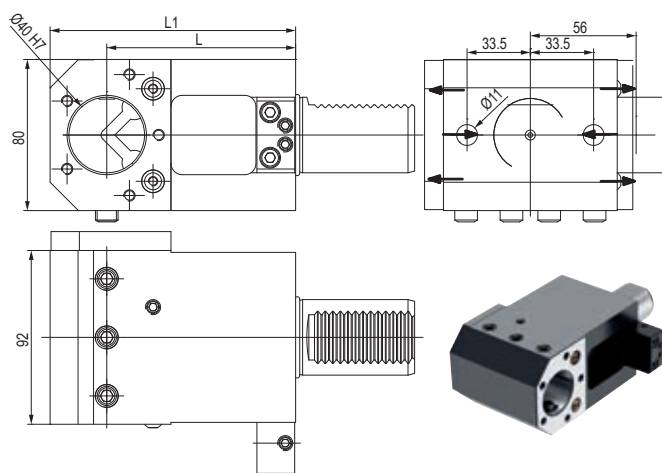

CODE N.	L	L1	CLAMPING SCREW1 (M12X20)	CLAMPING SCREW2 (M12X25)	COVER FOR INTERNAL COOLANT	SCREW FOR COVER
115-54132	100	130	811-102044	811-102045	832-003303	811-101027
115-54080	120	150	811-102044	811-102045	832-003236	811-101027

CODE N.	STOP NUT	INSERT FOR STOP NUT	SCREW FOR STOP NUT	SCREW FOR STOP NUT	O RING FOR VDI40	COOLANT NOZZLE
115-54132	832-003237	832-003238	811-101032	811-102027	823-101036	833-001080
115-54080	832-003237	832-003238	811-101032	811-102027	823-101036	833-001080

PORTAUTENSILE PER BARENI - TOOLHOLDER FOR BORING BAR

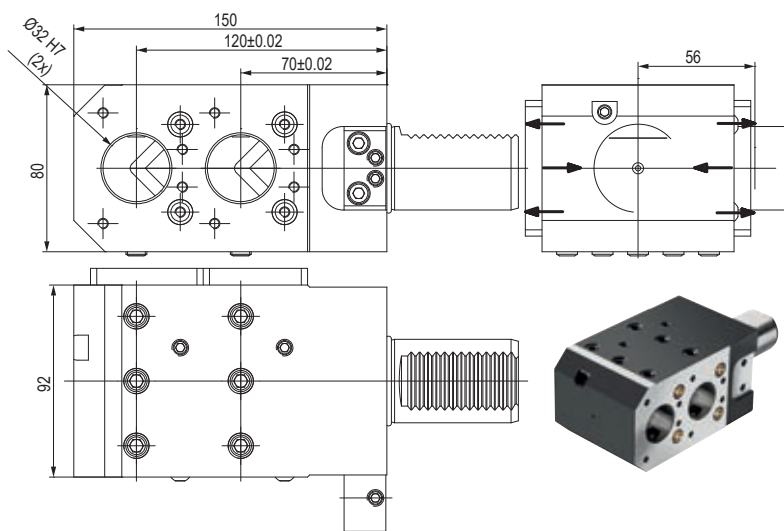

CODE N.	CLAMPING SCREW1 (M12X20)	CLAMPING SCREW2 (M10X25)	COVER1 FOR INTERNAL COOLANT	COVER2 FOR INTERNAL COOLANT	SCREW FOR COVER
115-54147	811-102044	811-102039	832-003318	832-003319	811-101017

CODE N.	STOP NUT	INSERT FOR STOP NUT	SCREW FOR STOP NUT	SCREW FOR STOP NUT	O RING FOR VDI40	COOLANT NOZZLE
115-54147	832-003237	832-003238	811-101032	811-102027	823-101036	833-001080

BUSSOLA PER PORTABARENI BORING BAR SLEEVE FOR TOOLHOLDER

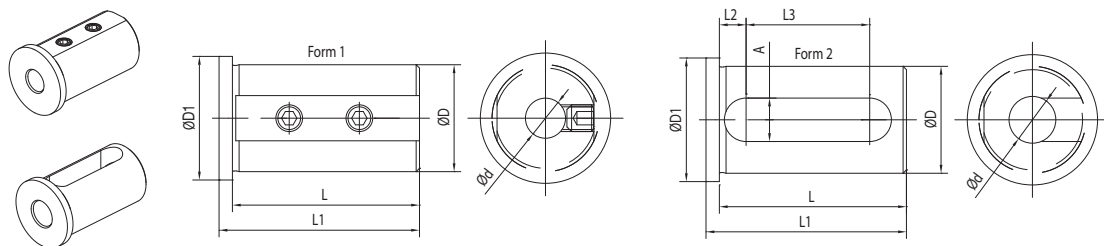

CODE N.	D	D	FORM	L	L1	L2	L3	A	D1
165-62551	25	8	1	46	50	-	-	-	30
165-62552	25	10	1	46	50	-	-	-	30
165-62553	25	12	1	46	50	-	-	-	30
165-62555	25	16	2	46	50	8	27	13	30
165-62557	25	20	2	46	50	8	27	13	30
165-63352	32	8	1	56	60	-	-	-	37
165-63353	32	10	1	56	60	-	-	-	37
165-63354	32	12	1	56	60	-	-	-	37
165-63356	32	16	2	56	60	8	37	13	37
165-63358	32	20	2	56	60	8	37	13	37
165-63359	32	25	2	56	60	8	37	13	37
165-64247	40	8	1	71	75	-	-	-	45
165-64248	40	10	1	71	75	-	-	-	45
165-64249	40	12	1	71	75	-	-	-	45
165-64251	40	16	2	71	75	8	52	13	45
165-64253	40	20	2	71	75	8	52	13	45
165-64254	40	25	2	71	75	8	52	13	45
165-64255	40	32	2	71	75	8	52	13	45

BUSSOLA PER PORTABARENI BORING BAR SLEEVE FOR TOOLHOLDER

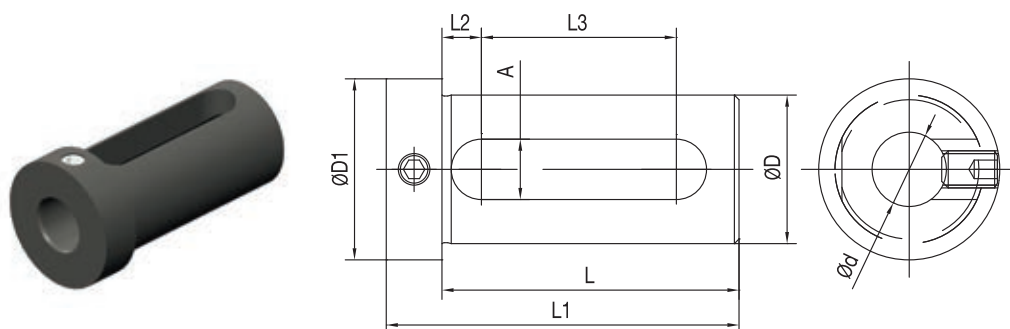

CODE N.	D	d	L	L1	L2	L3	A	D1
115-62044	20	8	50	60	7	29	11	28
115-62045	20	10	50	60	7	29	11	28
115-62046	20	12	50	60	7	29	11	28
165-62545	25	12	55	67	8	32	13	33
165-62547	25	16	55	67	8	32	13	33
165-62549	25	20	55	67	8	32	13	33
165-63347	32	16	65	77	8	42	13	39
165-63349	32	20	65	77	8	42	13	39
165-63350	32	25	65	77	8	42	13	39
165-64241	40	16	75	89	9	51	14	48
165-64243	40	20	75	89	9	51	14	48
165-64244	40	25	75	89	9	51	14	48
165-64245	40	32	75	89	9	51	14	48

DMG MORI (BMT40)

NZ 1500/2000/3100
 NZ / NTZ 1000/2000/3000/3100/3150/3200
 NZ / NZX 2000/2500 (16 station turret)
 NL / NLX 1500/2000/2500 (20 station turret)
 DURATURN 2050/2550 MC
 LTX310ECO-BMT

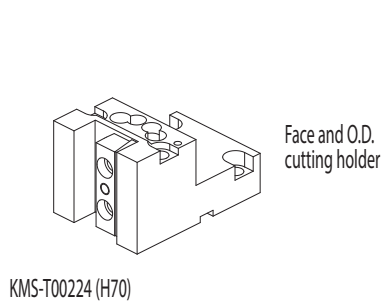

Qualified tool
 20x20 mm

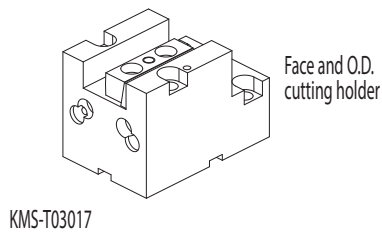
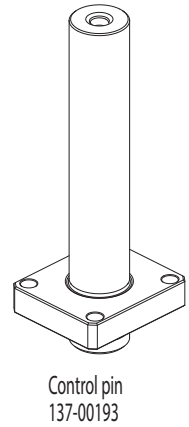
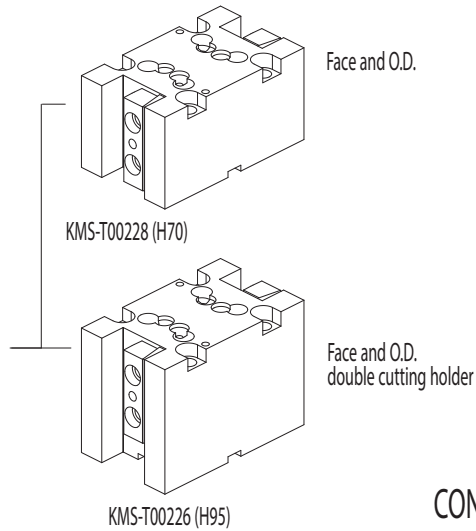

CONNECTION

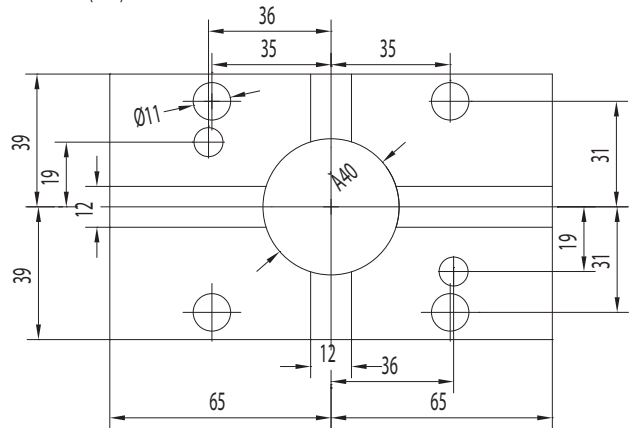

ACCESSORIES

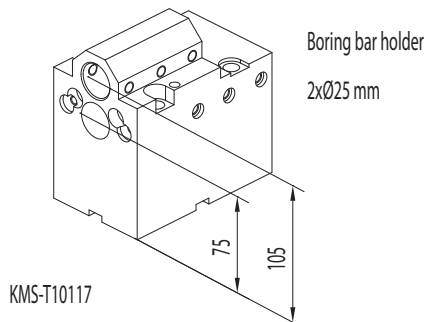
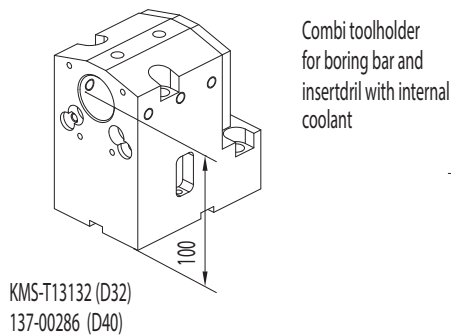
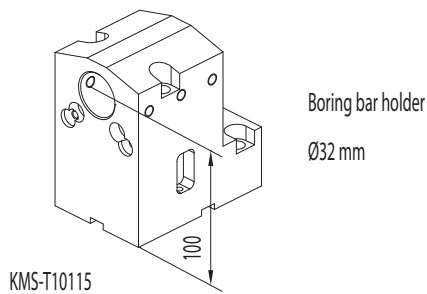

Boring bar sleeve D32

- KMS-T20122 (Ø25 mm)
- KMS-T20120 (Ø20 mm)
- KMS-T20118 (Ø16 mm)
- KMS-T20116 (Ø12 mm)
- KMS-T20114 (Ø10 mm)
- KMS-T20112 (Ø8 mm)

Boring bar sleeve D40

- KMS-T20098 (Ø32 mm)
- KMS-T20096 (Ø25 mm)
- KMS-T20094 (Ø20 mm)
- KMS-T20092 (Ø16 mm)
- KMS-T20090 (Ø12 mm)
- KMS-T20088 (Ø10 mm)
- KMS-T20086 (Ø8 mm)

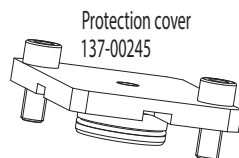

Driven tools

FAST-IN



124-04005
 124-04006 i.coolant

124-04007
 124-04008 i.coolant

CONNECTION

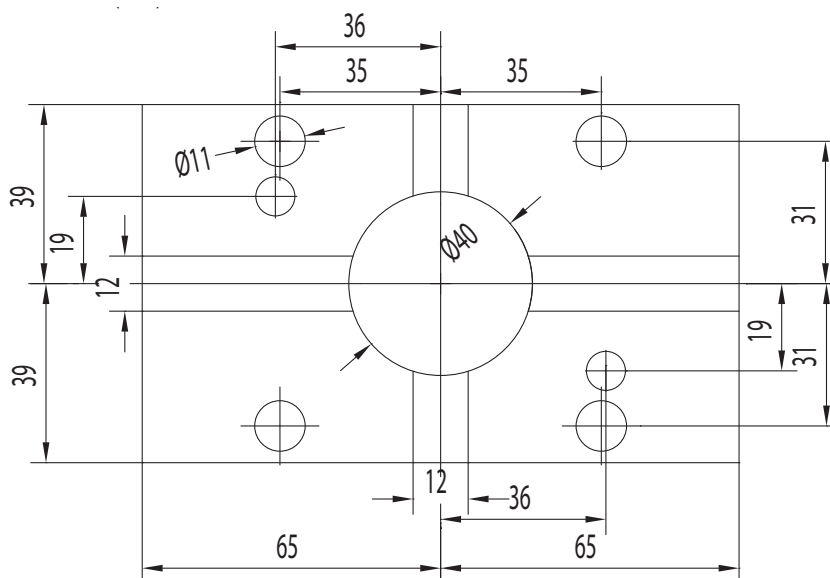

PORTAUTENSILE RADIALE - RADIAL TOOLHOLDERS

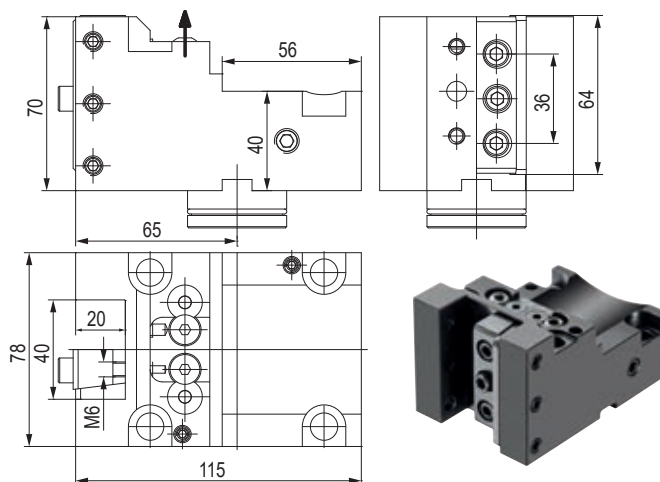

12

KINTEK®



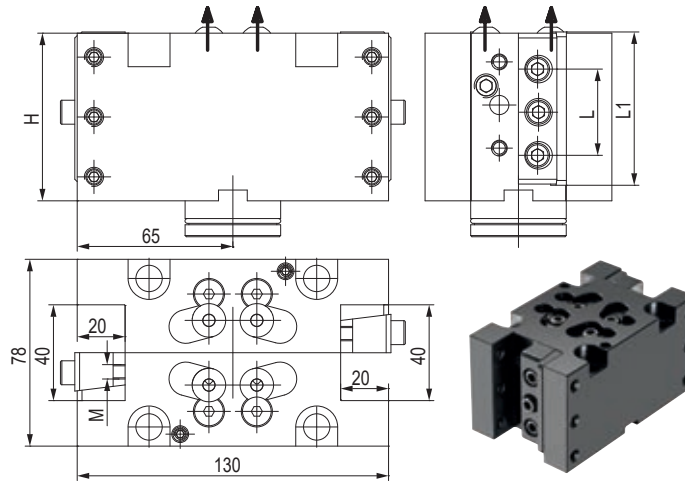

CODE N.	CLAMPING PLATE	CLAMPING SCREW	SCREW FOR DISASSEMBLE	COOLANT BALL	SCREW FOR BALL
KMS-T00224	832-020460	811-102029	811-104016	833-001470	811-108018

CODE N.	CENTRAL PIN	SCREW FOR PIN	O RING FOR PIN (36x2)	O RING FOR PIN (28X2)
KMS-T00224	832-020451	811-101029	823-101016	823-101018

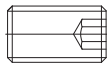
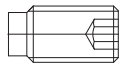
PORTAUTENSILE RADIALE - RADIAL TOOLHOLDERS

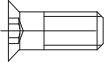

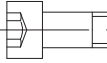

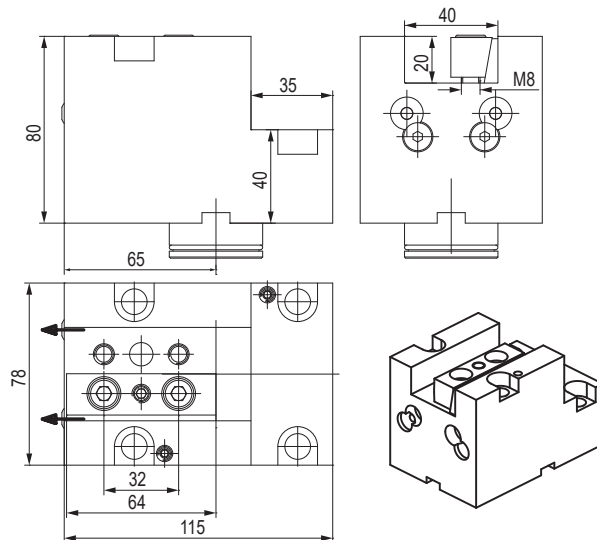

CODE N.	H	L	L1	M	CLAMPING PLATE	CLAMPING SCREW	SCREW FOR DISASSEMBLE
KMS-T00226	95	32	64	M8			
KMS-T00228	70	36	64	M6	832-020400	811-102029	811-104016

CODE N.	COOLANT BALL	SCREW FOR BALL	CENTRAL PIN	SCREW FOR PIN	O RING FOR PIN (36X2)	O RING FOR PIN (28X2)
						
KMS-T00226	833-001470	811-108018	832-020121	811-101029	823-101016	823-101018
KMS-T00228	833-001470	811-108018	832-020451	811-101029	823-101016	823-101018

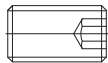
PORTAUTENSILE ASSIALE - AXIAL TOOLHOLDERS

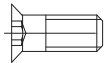

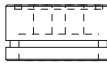
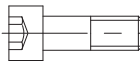
CODE N.	CLAMPING PLATE	SCREW FOR DISASSEMBLE	COOLANT BALL	SCREW FOR BALL
				
KMS-T03017	832-020400	811-102023	833-001470	811-108018

CODE N.	CENTRAL PIN	SCREW FOR PIN	O RING FOR PIN (36X2)	O RING FOR PIN (28X2)
				
KMS-T03017	832-020121	811-101029	823-101016	823-101018

PORTAUTENSILE PER BARENI - TOOLHOLDER FOR BORING BAR

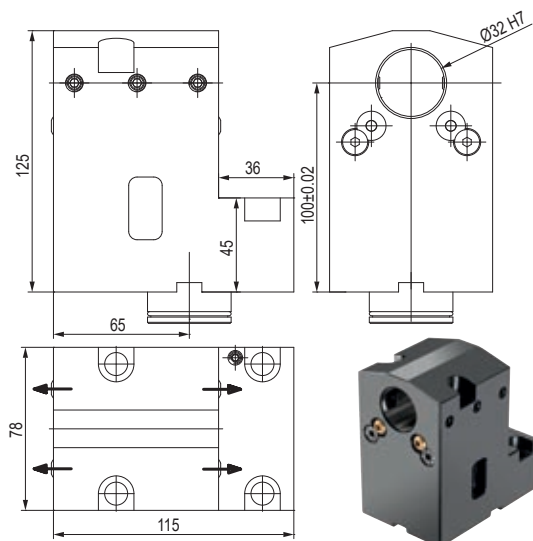

CODE N.	CLAMPING SCREW	SCREW FOR DISASSEMBLE	COOLANT BALL	SCREW FOR BALL
KMS-T10115	811-102030	811-102023	833-001470	811-108018

CODE N.	CENTRAL PIN	SCREW FOR PIN	O RING FOR PIN (36X2)	O RING FOR PIN (28X2)
KMS-T10115	832-020121	811-101029	823-101016	823-101018

PORTAUTENSILE COMBINATO PER BARENI E PUNTE A INSERTI COMBI TOOLHOLDER FOR BORING BAR AND INSERTDRILL

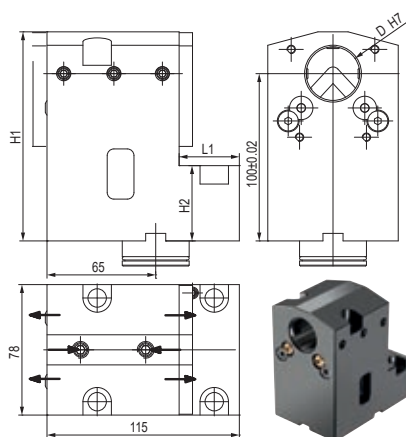

CODE N.	D	H1	H2	L1	CLAMPING SCREW1 (D32 M8X20) - (D40 M10X20)	CLAMPING SCREW2 (M10X10)	SCREW FOR DISASSEMBLE	COOLANT BALL	SCREW FOR BALL
KMS-T13132	32	125	45	36	811-102030	811-102035	811-102023	833-001470	811-108018
137-00286	40	129	33	26	811-102038	811-102035	811-102023	833-001470	811-108018

CODE N.	CENTRAL PIN	SCREW FOR PIN	O RING FOR PIN (36X2)	COD O RING FOR PIN (28X2)	COVER	SCREW FOR COVER
KMS-T13132	832-020121	811-101029	823-101016	823-101018	832-003378	811-101016
137-00286	832-020121	811-101029	823-101016	823-101018	832-003404	811-101016

PORTAUTENSILE PER BARENI - TOOLHOLDER FOR BORING BAR

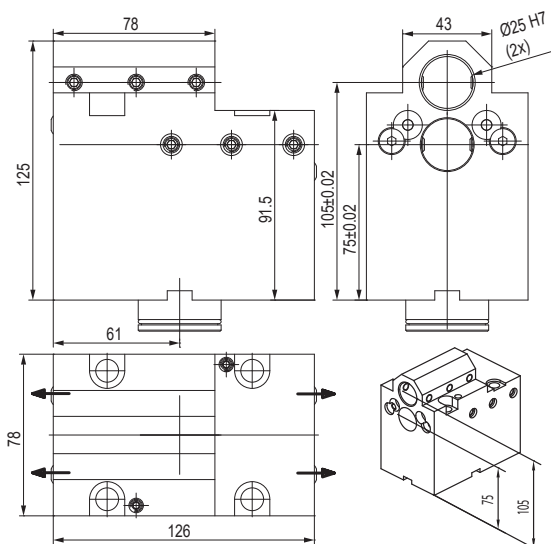

CODE N.	CLAMPING SCREW1 (M8X25)	CLAMPING SCREW2 (M8X20)	CLAMPING SCREW3 (M8X10)	SCREW FOR DISASSEMBLE	COOLANT BALL	SCREW FOR BALL
KMS-T10117	811-102031	811-102030	811-102027	811-102023	833-001470	811-108018

CODE N.	CENTRAL PIN	SCREW FOR PIN	O RING FOR PIN (36X2)	O RING FOR PIN (28X2)
KMS-T10117	832-020121	811-101029	823-101016	823-101018

PORTAUTENSILE MOTORIZZATO ASSIALE STRAIGHT DRILLING AND MILLING HEAD

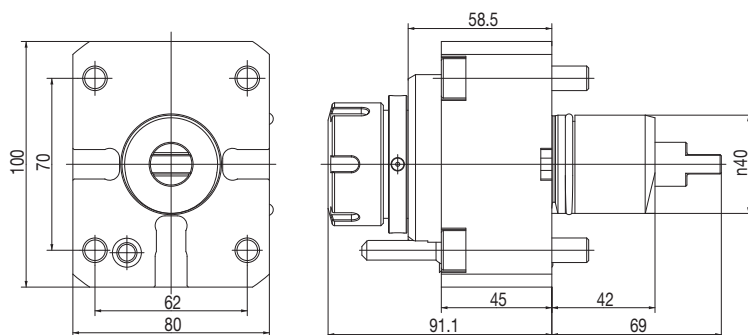

CODE N.	ER	MAX SPEED (Rpm)	I	MAX. TORQUE (Nm)	INTERNAL COOLING	P bar
124-04005	ER32	12000	1:1	50	no	-
124-04006	ER32	12000	1:1	50	yes	20

PORTAUTENSILE MOTORIZZATO RADIALE RADIAL DRILLING AND MILLING HEAD

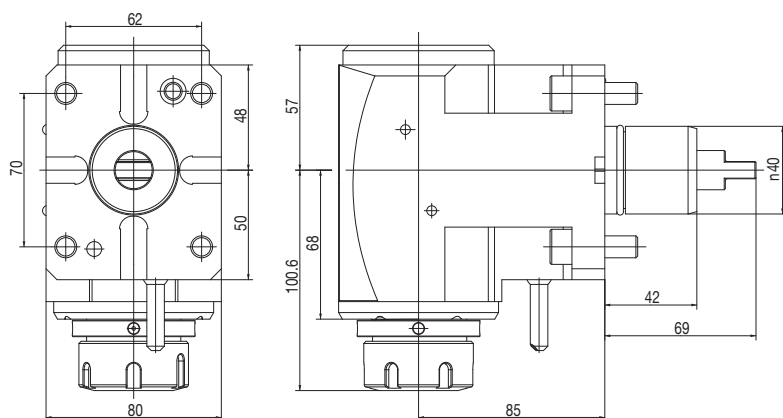

CODE N.	ER	MAX SPEED (Rpm)	I	MAX. TORQUE (Nm)	INTERNAL COOLING	P bar
124-04007	ER32	6000	1:1	50	no	-
124-04008	ER32	6000	1:1	50	yes	20

BARRA DI CONTROLLO - CONTROL PIN

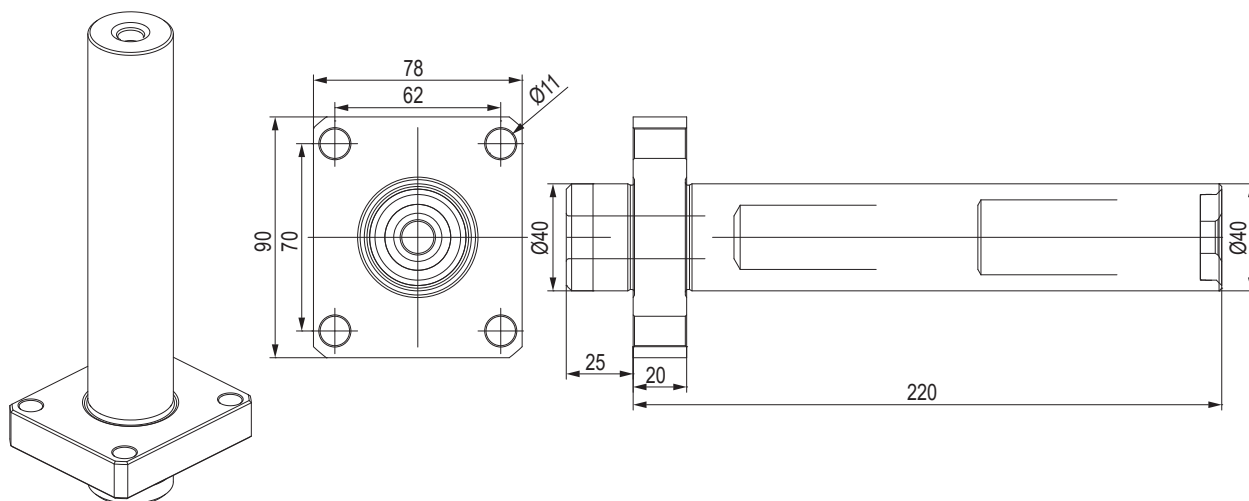

CODE N.



137-00193

TAPPO DI PROTEZIONE - PROTECTION COVER

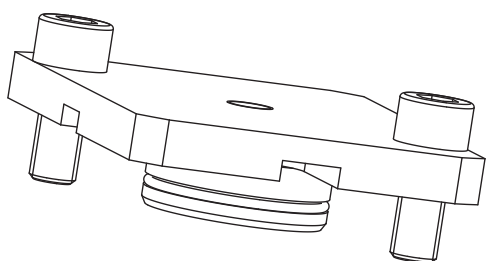
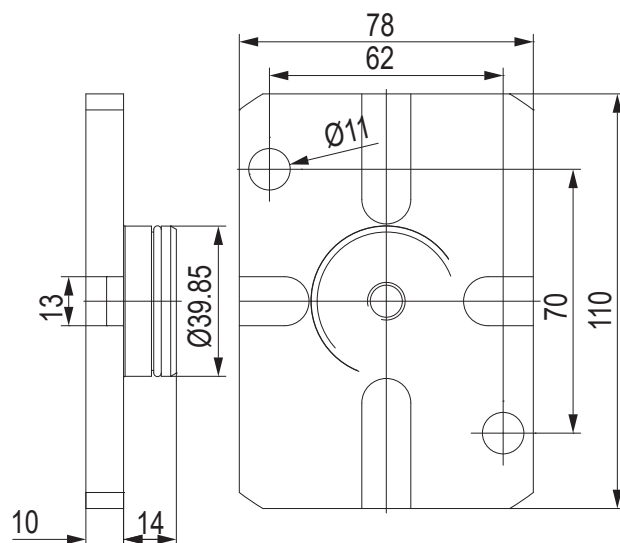

CODE N.	O RING COMP_2021-11
137-00245	823-101016

BUSSOLA PER PORTABARENI BORING BAR SLEEVE FOR TOOLHOLDER

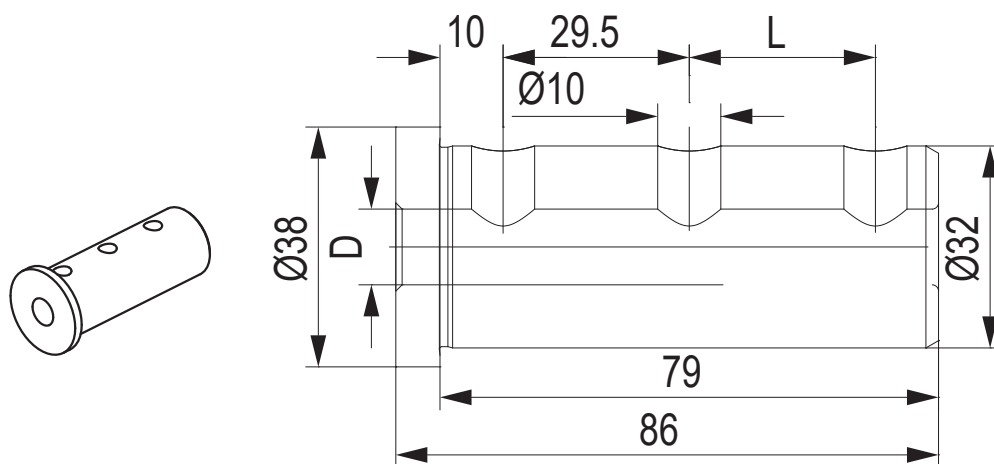

CODE N.	D	L
KMS-T20122	25	29.5
KMS-T20120	20	29.5
KMS-T20118	16	29.5
KMS-T20116	12	29.5
KMS-T20114	10	-
KMS-T20112	8	-

BUSSOLA PER PORTABARENI BORING BAR SLEEVE FOR TOOLHOLDER

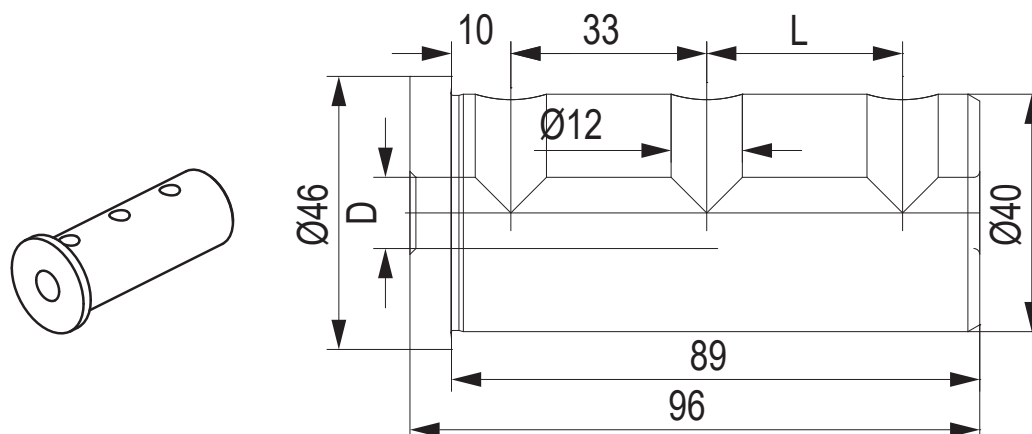

CODE N.	D	L
KMS-T20098	32	33
KMS-T20096	25	33
KMS-T20094	20	33
KMS-T20092	16	33
KMS-T20090	12	-
KMS-T20086	8	-
KMS-T20088	10	-



DMG MORI (BMT60)

NLX1500 (12 stazioni) - NLX2000
 NLX2500 - NLX3000 - NLX4000
 NL2000 (S)MC - 2500 (S)MC
 NL3000MC (12 STATIONS)
 NT3250 - NT4200 - NT4250
 NT4300 - NT5400 - NZL2500
 NT4000 - NT5000
 NZL 2000/2500
 NZX 2500 (station turret)
 NTX 2000/2500/3000
 2ND GEN. 10ST. - (TX2500 BMT60)

GOODWAY

G4/G5 200
 2600/280
 3000/3300
 3600
 GS2000 SERIES
 GS3000 SERIES
 GS4000 SERIES

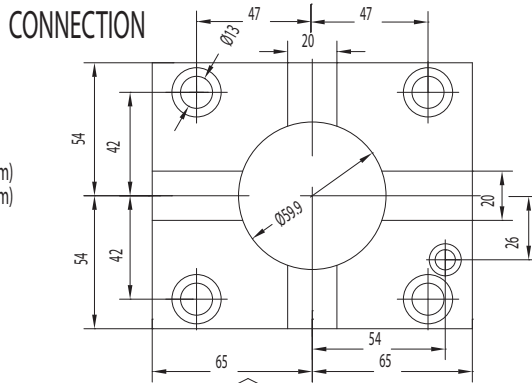
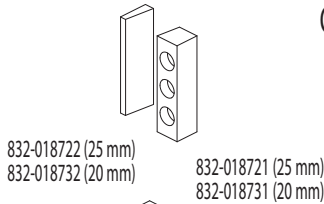

124-06001
124-06003 I.Coolant

124-06002
124-06004 I.Coolant

FAST-IN

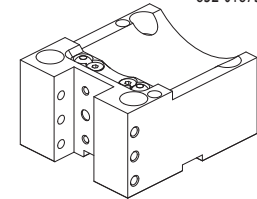

KMS-T00186 (25x25 mm)
KMS-T00187 (20x20 mm)

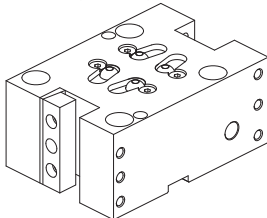

KMS-T00184 (25x25 mm)
KMS-T00185 (20x20 mm)

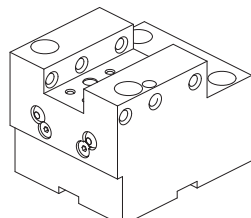

KMS-T03005 (25x25 mm)
KMS-T03006 (20x20 mm)

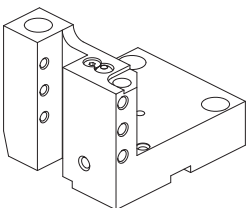

KMS-T00197 (25x25 mm)

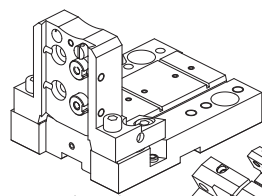

137-00092 (32 mm)

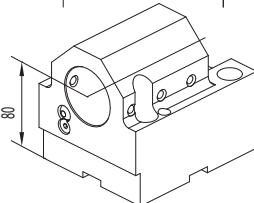
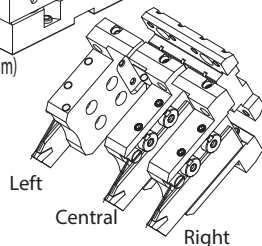

KMS-T10097 (Ø40 mm)
KMS-T10098 (Ø50 mm)

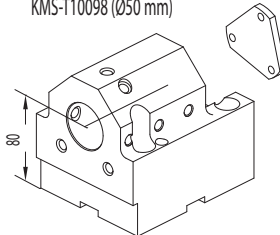

KMS-T13128 (Ø40 mm)
with internal coolant

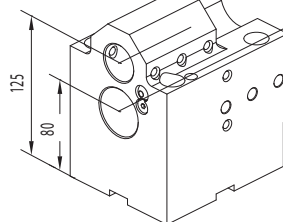

KMS-T10096 (Ø32 mm)

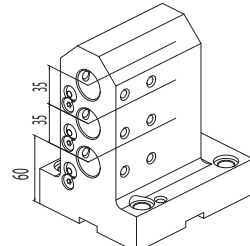

KMS-T10104 (Ø25 mm)

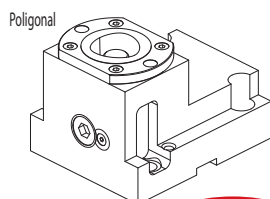

137-00241 (C40)
137-00187 (C50)

NEWS

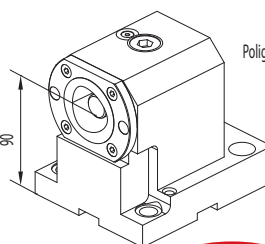

137-00242 (C40)
137-00183 (C50)

NEWS

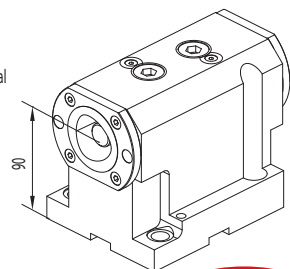

137-00243 (C40)
137-00185 (C50)

NEWS

ACCESSORIES

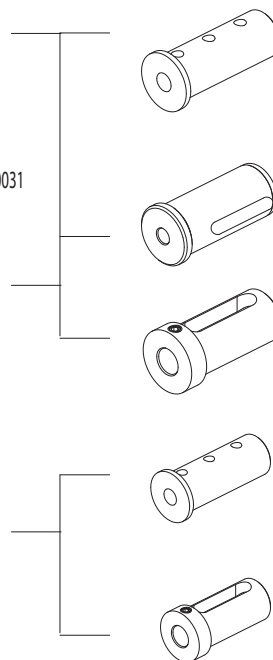

KMS-T20098 (Ø32 mm)
KMS-T20096 (Ø25 mm)
KMS-T20094 (Ø20 mm)
KMS-T20092 (Ø16 mm)
KMS-T20090 (Ø12 mm)
KMS-T20088 (Ø10 mm)
KMS-T20086 (Ø8 mm)

KMS-T22042 (MT3)
KMS-T22046 (MT2)

165-64241 (Ø16 mm)
165-64243 (Ø20 mm)
165-64244 (Ø25 mm)
165-64245 (Ø32 mm)

KMS-T20122 (Ø25 mm)
KMS-T20120 (Ø20 mm)
KMS-T20118 (Ø16 mm)
KMS-T20116 (Ø12 mm)
KMS-T20114 (Ø10 mm)
KMS-T20112 (Ø8 mm)

165-63347 (Ø16 mm)
165-63349 (Ø20 mm)
165-63350 (Ø25 mm)

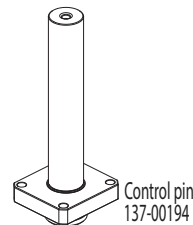

Control pin
137-00194



Protection cover
137-00246

CONNECTION

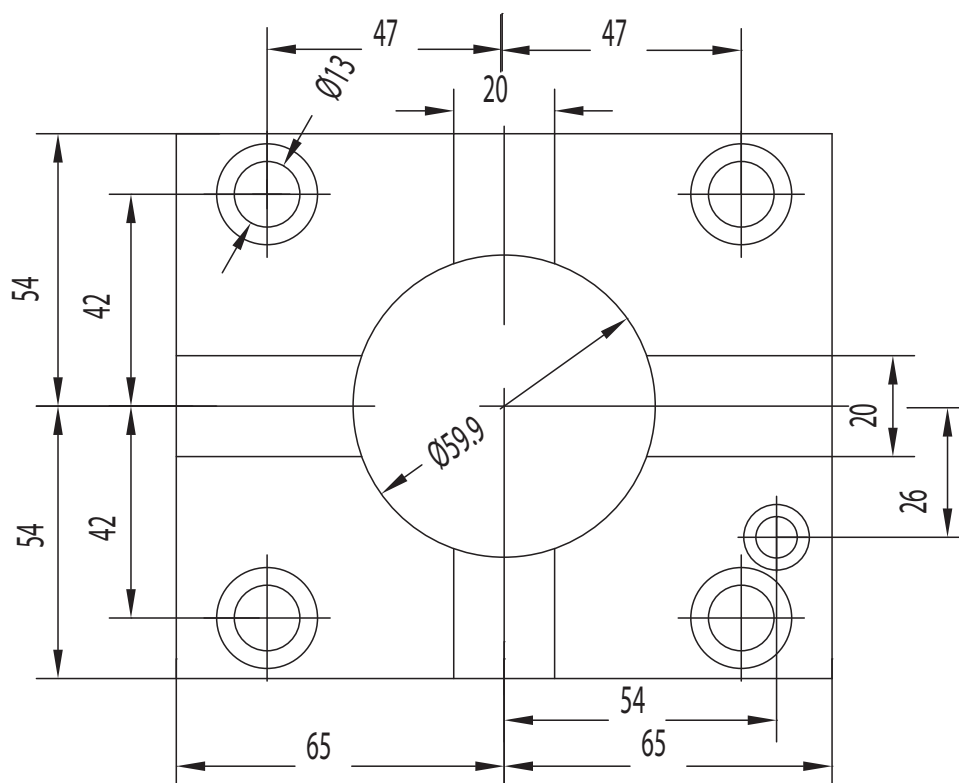

PORTAUTENSILE RADIALE - RADIAL TOOLHOLDERS

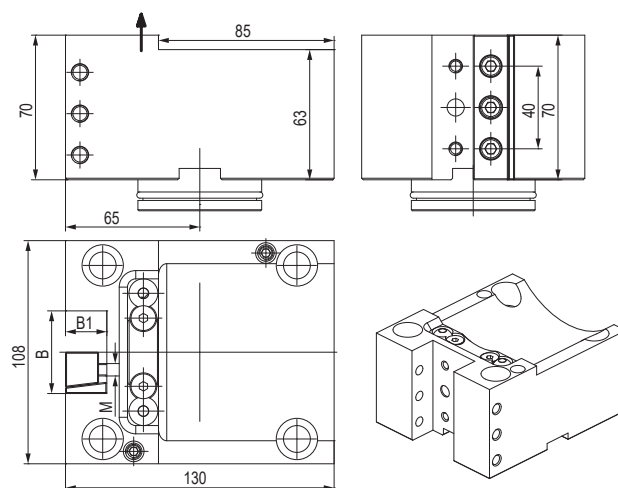

CODE N.	B	B1	M	CLAMPING PLATE	CLAMPING SCREW	SCREW FOR DISASSEMBLE	COOLANT BALL	SCREW FOR BALL
KMS-T00186	50	25	M8					
KMS-T00187	40	20	M6	832-018730	811-104021	811-102102	833-001470	811-108018

CODE N.	CENTRAL PIN	SCREW FOR PIN	O RING FOR PIN (54X3)	O RING FOR PIN (44.5X3)	O RING FOR COOLANT (9.25X1.78)
KMS-T00186					
KMS-T00187	832-018741	811-101041	823-101077	823-101069	823-101076

PORTAUTENSILE RADIALE - RADIAL TOOLHOLDERS

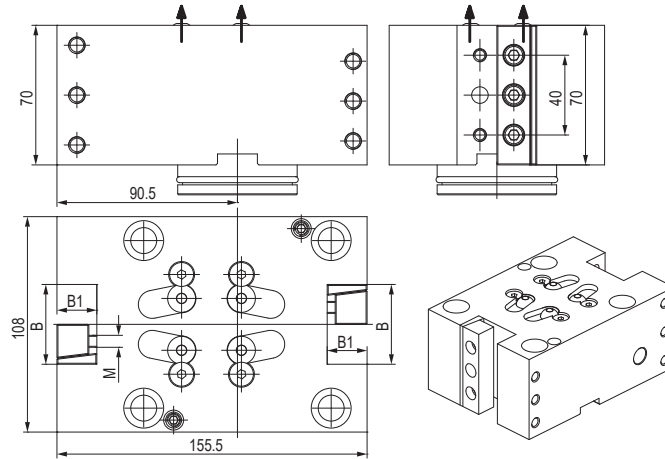

CODE N.	B	B1	M	CLAMPING PLATE	CLAMPING SCREW	SCREW FOR DISASSEMBLE	COOLANT BALL	SCREW FOR BALL
KMS-T00184	50	25	M8	832-018720	811-104021	811-102102	833-001470	811-108018
KMS-T00185	40	20	M6	832-018730	811-104021	811-102102	833-001470	811-108018

CODE N.	CENTRAL PIN	SCREW FOR PIN	O RING FOR PIN (54X3)	O RING FOR PIN (44.5X3)	O RING FOR COOLANT (9.25X1.78)
KMS-T00184	832-018741	811-101041	823-101077	823-101069	823-101076
KMS-T00185	832-018741	811-101041	823-101077	823-101069	823-101076

PORTAUTENSILE ASSIALE - AXIAL TOOLHOLDERS

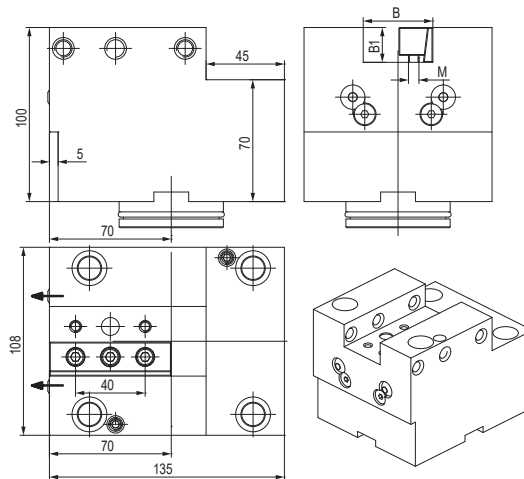

CODE N.	B	B1	M	CLAMPING PLATE	CLAMPING SCREW	SCREW FOR DISASSEMBLE	COOLANT BALL	SCREW FOR BALL
KMS-T03005	50	25	M8	832-018720	811-104030	811-102102	833-001470	811-108018
KMS-T03006	40	20	M6	832-018730	811-104030	811-102102	833-001470	811-108018

CODE N.	CENTRAL PIN	SCREW FOR PIN	O RING FOR PIN (54X3)	O RING FOR PIN (44.5X3)	O RING FOR COOLANT (9.25X1.78)
KMS-T03005	832-018741	811-101041	823-101077	823-101069	823-101076
KMS-T03006	832-018741	811-101041	823-101077	823-101069	823-101076

PORTALAMA - CUT-OFF TOOLHOLDERS

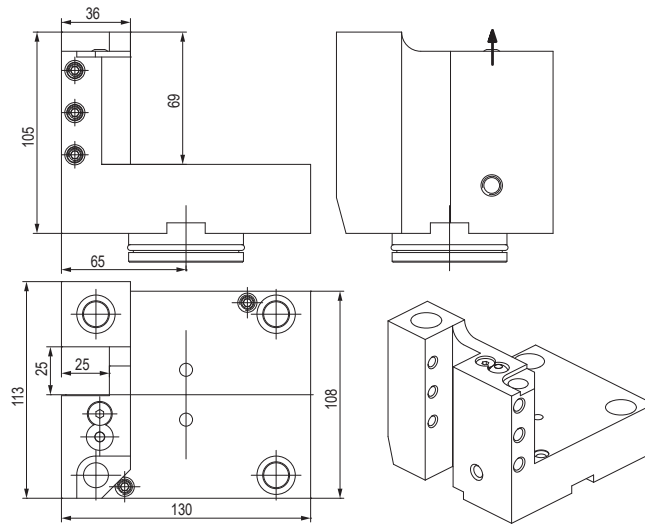

CODE N.	CLAMPING SCREW	SCREW FOR DISASSEMBLE	COOLANT BALL	SCREW FOR BALL
KMS-T00197	811-104021	811-102032	833-001470	811-108018

CODE N.	CENTRAL PIN	SCREW FOR PIN	O RING FOR PIN (54X3)	O RING FOR PIN (44.5X3)	O RING FOR COOLANT (9.25X1.78)
KMS-T00197	832-018741	811-101041	823-101077	823-101069	823-101076

PORTALAMA - CUT-OFF TOOLHOLDERS

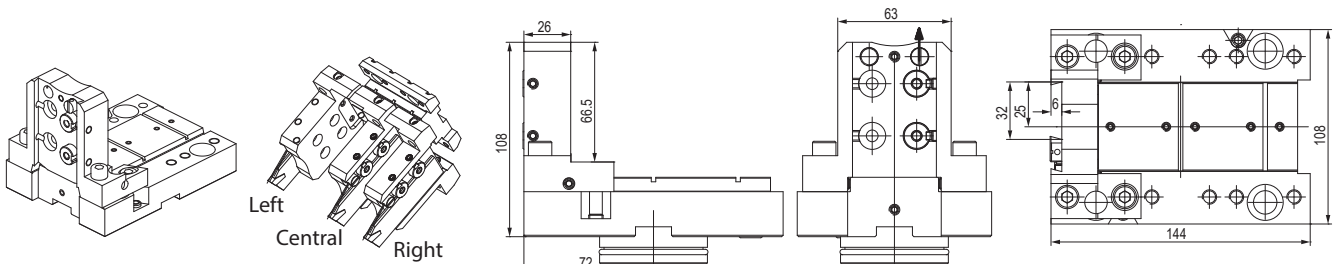

CODE N.	SCREW FOR DISASSEMBLE	COOLANT NOZZLE	O RING FOR COOLANT NOZZLE	O RING FOR BODY
137-00092	811-102028	833-001490	823-101058	823-101061

CODE N.	SHIM PLATE	SCREW FOR PLATE	CLAMPING PIN	SPRING	CLAMPING SCREW	SCREW
137-00092	832-014449	811-108037	832-014450	824-300012	811-101028	811-104013

CODE N.	CENTRAL PIN	SCREW FOR PIN	O RING FOR PIN (54.5X3)	O RING FOR PIN (44.5X3)	O RING FOR COOLANT (9X2)
137-00092	832-018741	811-101041	823-101070	823-101069	823-101015

PORTAUTENSILE PER BARENI - TOOLHOLDER FOR BORING BAR

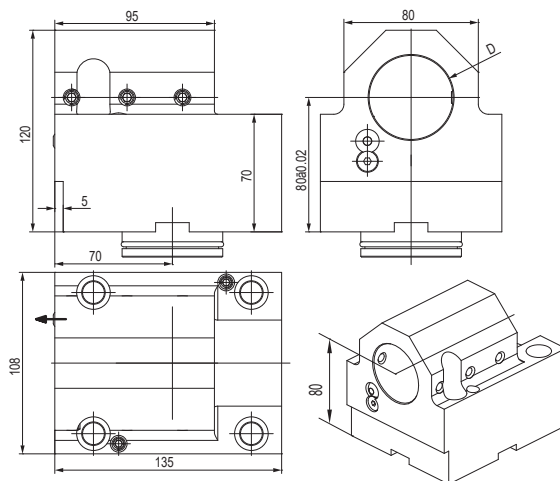

CODE N.	D	CLAMPING SCREW	SCREW FOR DISASSEMBLE	COOLANT BALL	SCREW FOR BALL
KMS-T10097	40	811-104028	811-102102	833-001470	811-108018
KMS-T10098	50	811-104028	811-102102	833-001470	811-108018

CODE N.	CENTRAL PIN	SCREW FOR PIN	O RING FOR PIN (54X3)	O RING FOR PIN (44.5X3)	O RING FOR COOLANT (9.25X1.78)
KMS-T10097	832-018741	811-101041	823-101077	823-101069	823-101076
KMS-T10098	832-018741	811-101041	823-101077	823-101069	823-101076

PORTAUTENSILE COMBINATO PER BARENI E PUNTE A INSERTI COMBI TOOLHOLDER FOR BORING BAR AND INSERT DRILL

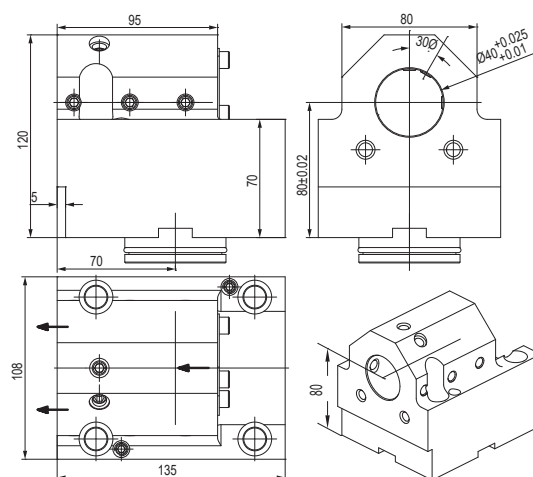



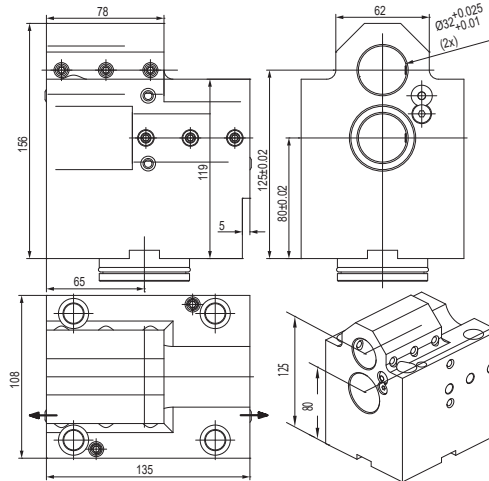

CODE N.	CLAMPING SCREW	SCREW FOR DISASSEMBLE	COVER F70031	SCREW FOR COVER
KMS-T13128	811-104028	811-102032	832-003229	811-101028

CODE N.	CENTRAL PIN	SCREW FOR PIN	O RING FOR PIN (54X3)	O RING FOR PIN (44.5X3)	O RING FOR COOLANT (9.25X1.78)
KMS-T13128	832-018741	811-101041	823-101077	823-101069	823-101076

PORTAUTENSILE DOPPIO PER BARENI DOUBLE TOOLHOLDER FOR BORING BAR

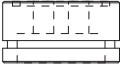
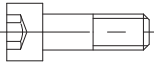







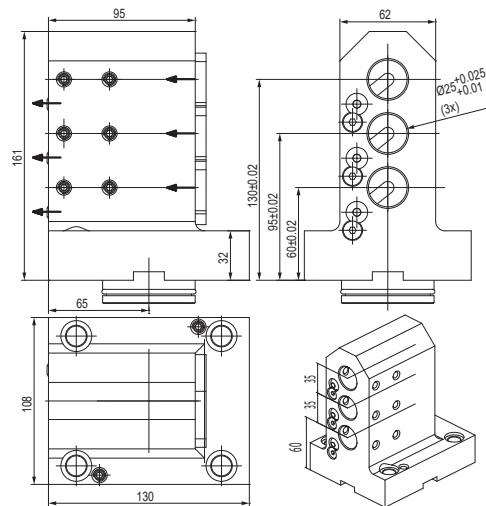

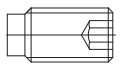
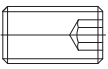
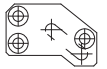
CODE N.	CLAMPING SCREW	SCREW FOR DISASSEMBLE	COOLANT BALL	SCREW FOR BALL
KMS-T10096				
	811-104021	811-102102	833-001470	811-108018

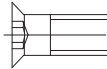
CODE N.	CENTRAL PIN	SCREW FOR PIN	O RING FOR PIN (54X3)	O RING FOR PIN (44.5X3)	O RING FOR COOLANT (9.25X1.78)
KMS-T10096					
	832-018741	811-101041	823-101077	823-101069	823-101076

PORTAUTENSILE TRIPLO PER BARENI TOOLHOLDER FOR BORING BAR

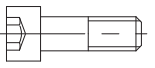

CODE N.	CLAMPING SCREW	SCREW FOR DISASSEMBLE	COVER T10104-2	COOLANT BALL	SCREW FOR BALL AND COVER
KMS-T10104					
	811-104021	811-102032	832-003241	833-001470	811-108018

CODE N.	CENTRAL PIN	SCREW FOR PIN	O RING FOR PIN (54X3)	O RING FOR PIN (44.5X3)	O RING FOR COOLANT (9.25X1.78)
KMS-T10104					
	832-018741	811-101041	823-101077	823-101069	823-101076

PORTAUTENSILE CON USCITA POLIGONALE POLIGONAL TOOLHOLDERS

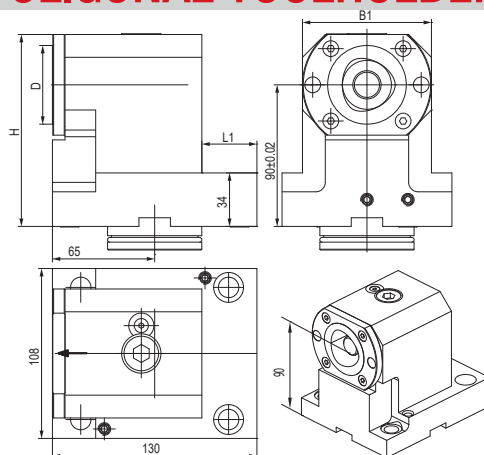

CODE N.	CAPTO	D	H	L1	B1	CLAMPING UNIT	SCREW FOR DISASSEMBLE
---------	-------	---	---	----	----	---------------	-----------------------



137-00242	C40	40	114	45	67	CXC40-10	811-102032
137-00183	C50	50	122	35	82	CXC50-10	811-102032

CODE N.	CENTRAL PIN	SCREW FOR PIN	O RING FOR PIN (54X3)	O RING FOR PIN (44.5X3)	O RING FOR COOLANT (9.25X1.78)
---------	-------------	---------------	-----------------------	-------------------------	--------------------------------

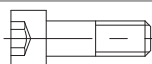
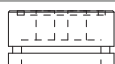

137-00242	832-018741	811-101041	823-101077	823-101069	823-101076
137-00183	832-018741	811-101041	823-101077	823-101069	823-101076

PORTAUTENSILE CON USCITA POLIGONALE POLIGONAL TOOLHOLDERS

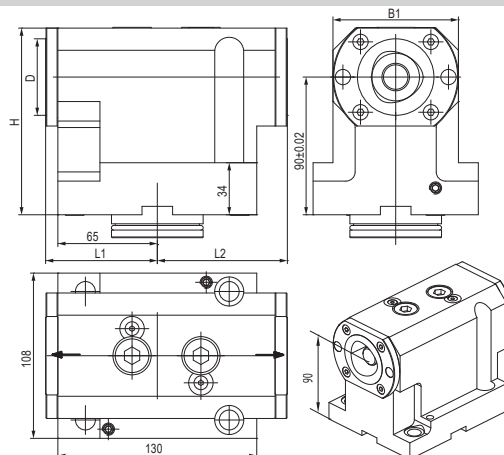

CODE N.	CAPTO	D	D	H	L1	B1	CLAMPING UNIT	SCREW FOR DISASSEMBLE
---------	-------	---	---	---	----	----	---------------	-----------------------

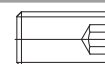

137-00243	C40	40	114	71	71	67	CXC40-10	811-102032
137-00185	C50	50	122	73	85	82	CXC50-10	811-102032

CODE N.	CENTRAL PIN	SCREW FOR PIN	O RING FOR PIN (54X3)	O RING FOR PIN (44.5X3)	O RING FOR COOLANT (9.25X1.78)
---------	-------------	---------------	-----------------------	-------------------------	--------------------------------

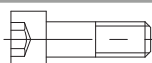
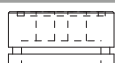

137-00243	832-018741	811-101041	823-101077	823-101069	823-101076
137-00185	832-018741	811-101041	823-101077	823-101069	823-101076

PORTAUTENSILE CON USCITA POLIGONALE POLIGONAL TOOLHOLDERS

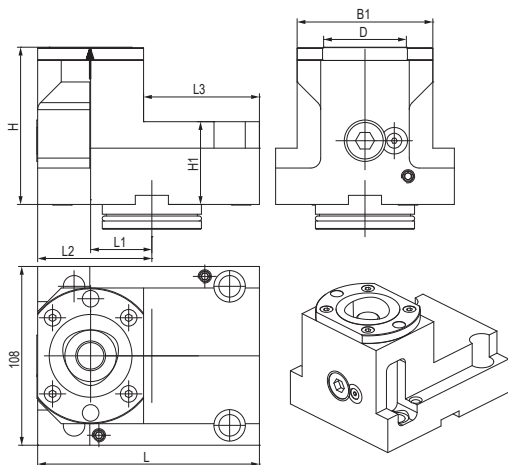

CODE N.	CAPTO	D	H	H1	L	L1	L2	L3	B1	CLAMPING UNIT	SCREW FOR DISASSEMBLE
---------	-------	---	---	----	---	----	----	----	----	---------------	-----------------------



137-00241	C40	40	80	42	130	41	65	82	67	CXC40-10	811-102032
137-00187	C50	50	95	50	134	37	69	70	82	CXC50-10	811-102032

CODE N.	CENTRAL PIN	SCREW FOR PIN	O RING FOR PIN (54X3)	O RING FOR PIN (44.5X3)	O RING FOR COOLANT (9.25X1.78)
137-00241	832-018741	811-101041	823-101077	823-101069	823-101076
137-00187	832-018741	811-101041	823-101077	823-101069	823-101076

PORTAUTENSILE MOTORIZZATO ASSIALE STRAIGHT DRILLING AND MILLING HEAD

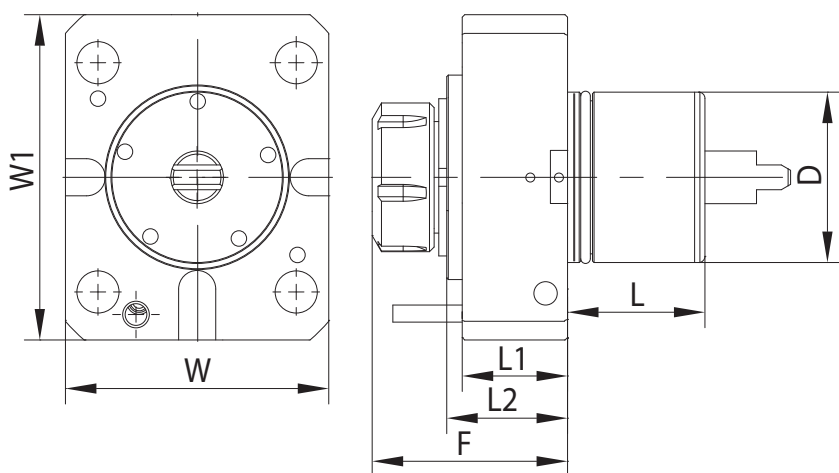

CODE N.	ER	D	F	L	L1	L2	W	W1	MAX. TORQUE (Nm)	NMAX (Rpm)	I	INTERNAL COOLING	P Bar
124-06001	ER32	60	89	53	48.5	58	108	130	70	6000	1:1	no	-
124-06003	ER32	60	89	53	48.5	58	108	130	70	6000	1:1	yes	20

PORTAUTENSILE MOTORIZZATO RADIALE ANGULAR DRILLING AND MILLING HEAD

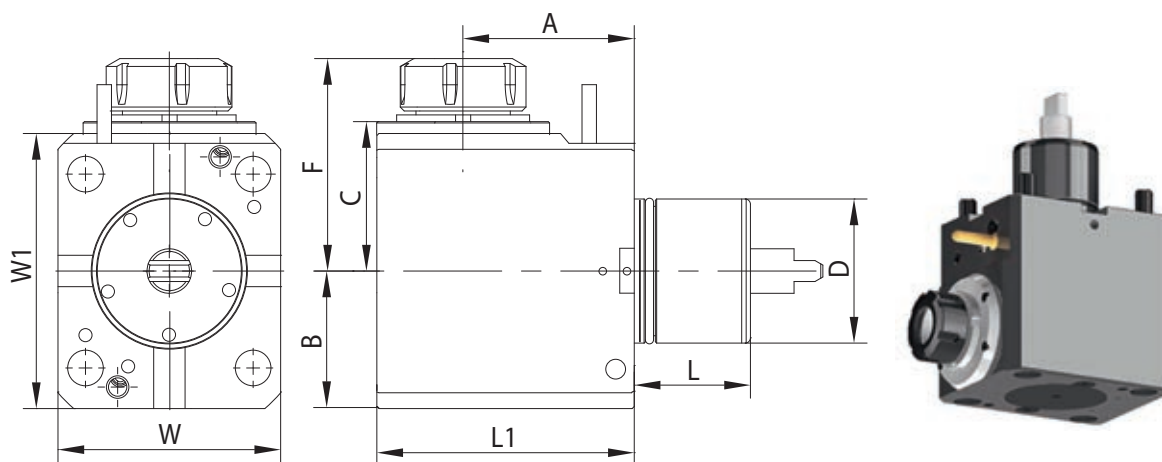

CODE N.	ER	D	F	L	L1	A	B	C	W	W1	MAX. TORQUE (Nm)	NMAX (Rpm)	I	INTERNAL COOLING	P Bar
124-06002	ER32	60	107	53	128	90	65	78	108	130	70	6000	1:1	no	-
124-06004	ER32	60	107	53	128	90	65	78	108	130	70	6000	1:1	yes	20

BARRA DI CONTROLLO - CONTROL PIN

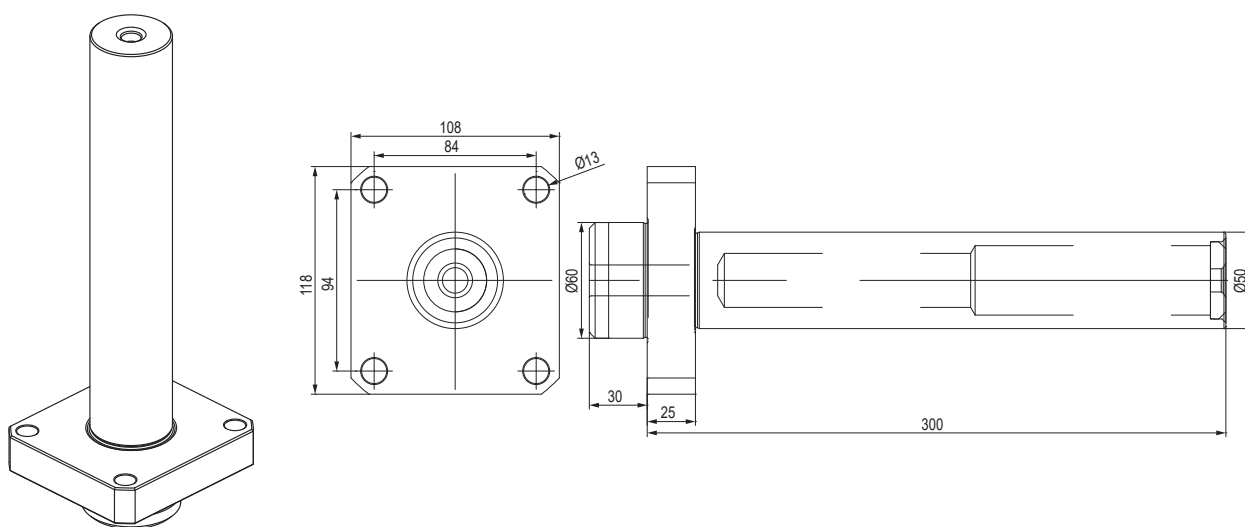

CODE N.

137-00194

TAPPO DI PROTEZIONE - PROTECTION COVER

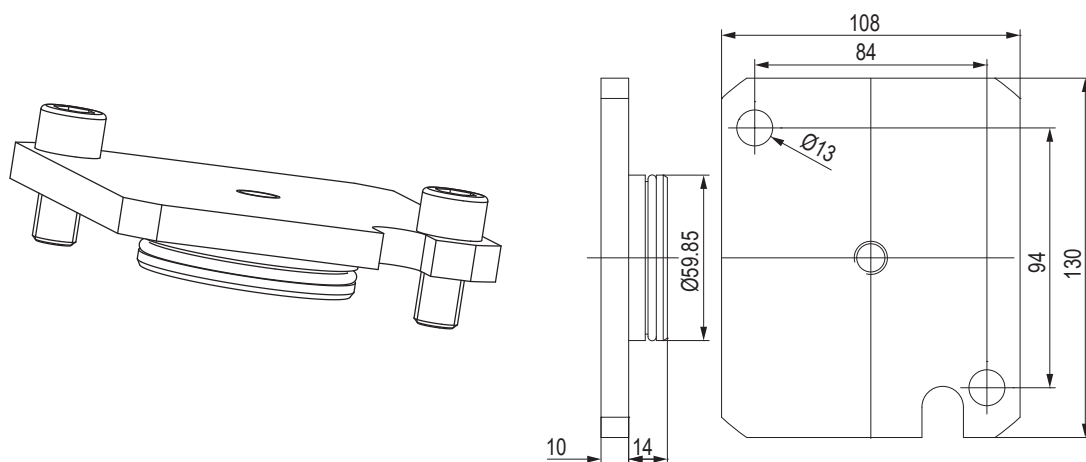

CODE N.

O RING



137-00246

823-101077

BUSSOLA PER PORTABARENI BORING BAR SLEEVE FOR TOOLHOLDER

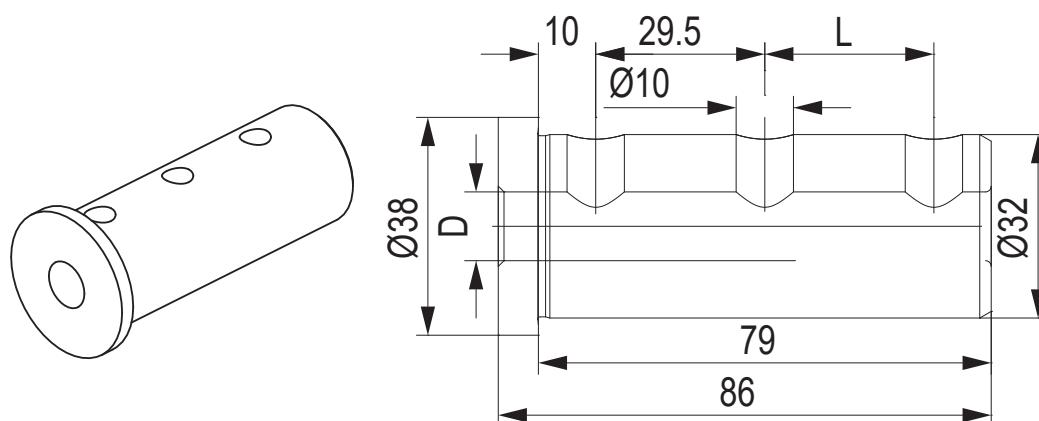

CODE N.	D	L	TYPE	SCREW
---------	---	---	------	-------



KMS-T20098	32	33	B	-
KMS-T20096	25	33	B	811-102017
KMS-T20094	20	33	A	811-102017
KMS-T20092	16	33	A	811-102017
KMS-T20090	12	-	A	811-102017
KMS-T20088	10	-	A	811-102017
KMS-T20086	8	-	A	811-102017

BUSSOLA PER PORTABARENI DRILL SOCKET FOR TOOLHOLDER

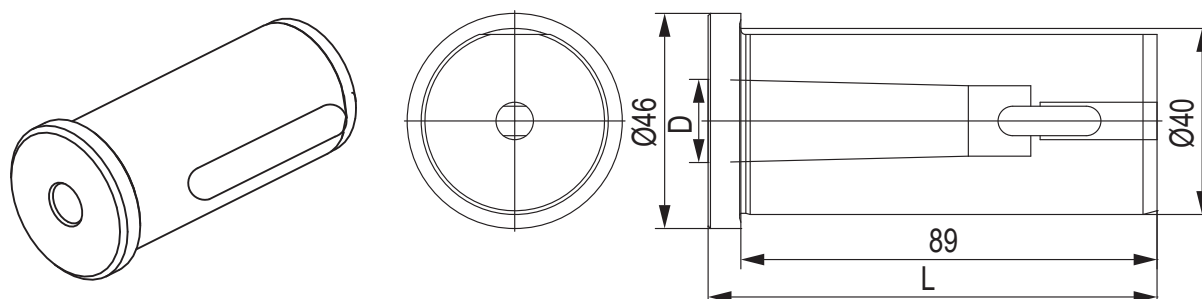

CODE N.	MORSE	D	H
KMS-T22042	3	23.825	108
KMS-T22046	2	17.78	96

BUSSOLA PER PORTABARENI BORING BAR SLEEVE FOR TOOLHOLDER

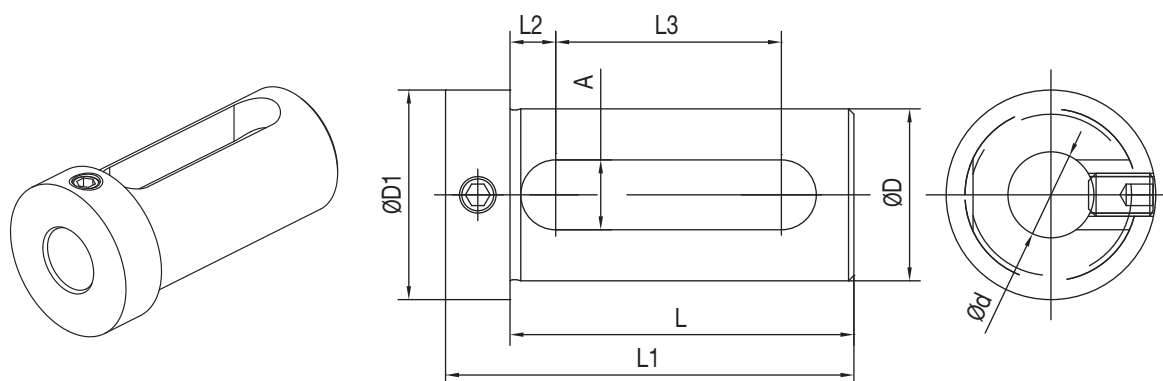

CODEN.	D	d	L	L1	L2	L3	A	D1
165-64241	40	16	74	88	9	51	14	48
165-64243	40	20	74	88	9	51	14	48
165-64244	40	25	74	88	9	51	14	48
165-64245	40	32	74	88	9	51	14	48

BUSSOLA PER PORTABARENI BORING BAR SLEEVE FOR TOOLHOLDER

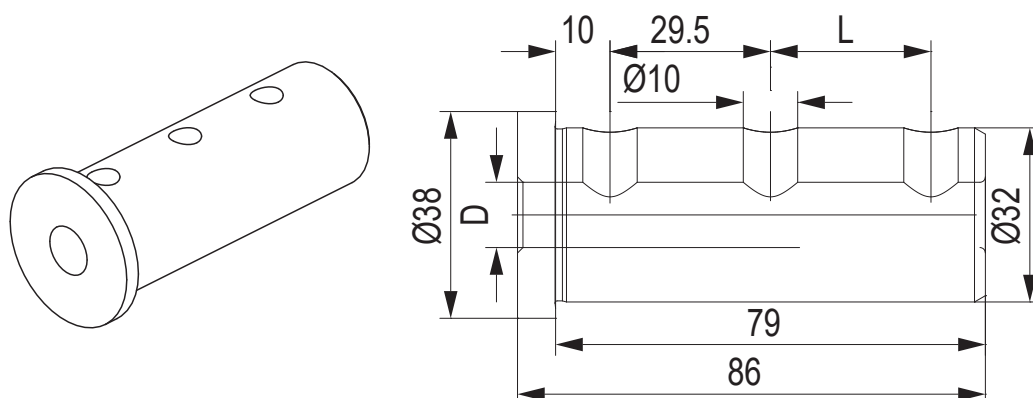

CODE N.	D	L	TYPE
KMS-T20122	25	29.5	B
KMS-T20120	20	29.5	B
KMS-T20118	16	29.5	A
KMS-T20116	12	29.5	A
KMS-T20114	10	-	A
KMS-T20112	8	-	A

BUSSOLA PER PORTABARENI BORING BAR SLEEVE FOR TOOLHOLDER

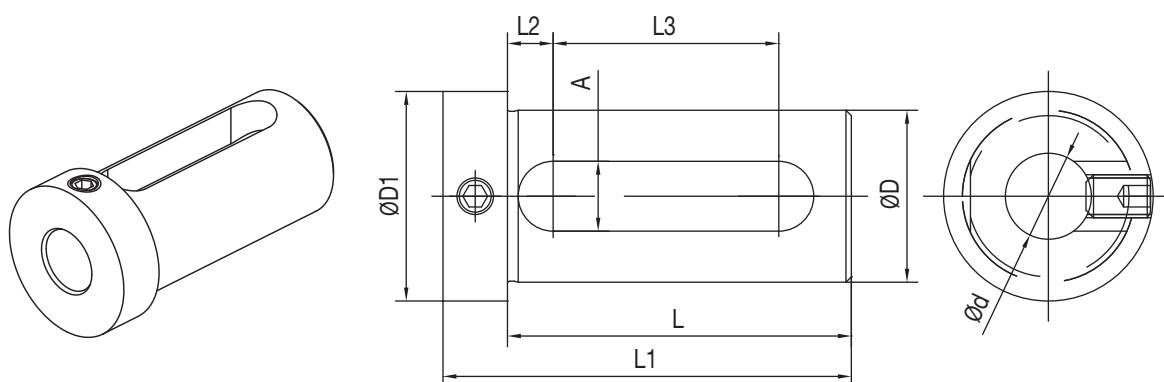

CODE N.	D	d	L	L1	L2	L3	A	D1
165-63347	32	16	64	76	8,5	42	13	39
165-63349	32	20	64	76	8,5	42	13	39
165-63350	32	25	64	76	8,5	42	13	39

DMG MORI

CL 200/203
 SL 20/25
 SL 203/204/250/253
 SL 254 (MC, SMC)/2500Y
 SL 203MC
 SL 253MC
 ZL 200MC
 ZL 250SMC
 SL 204SMC
 SL 300MC

CMZ

TBI 520
 TL 20/25
 TC 15/20/25/30/35
 TA 15M/Y/MS/MY/YS
 TA 20M/Y/MS/MY/YS
 TA 25M/Y/MS/MY/YS
 TA 30M/Y/MS/MY/YS
 TD 15/20/25/30/35/45
 TD 55M/Y/MS/MY/YS

GOODWAY

GS 200/260/280
 GA 2000/2600/2800
 GA 3000/3300/3600

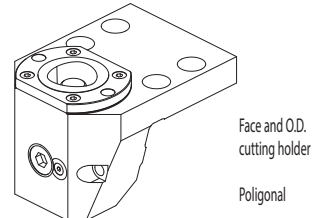
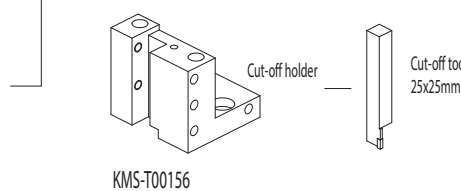
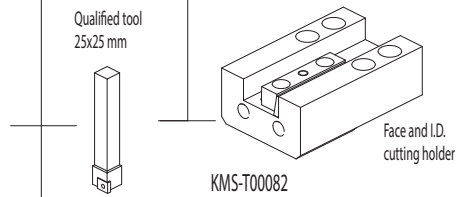
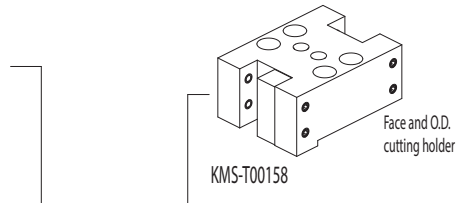
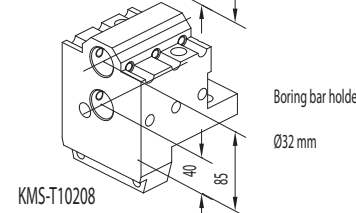
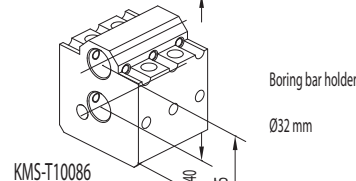
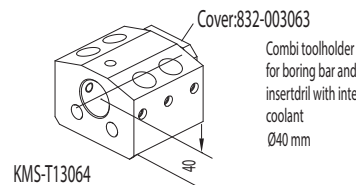
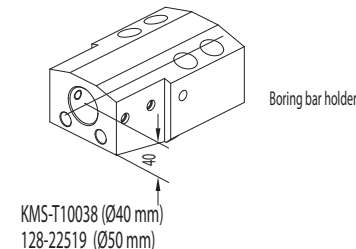
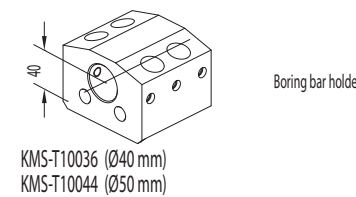
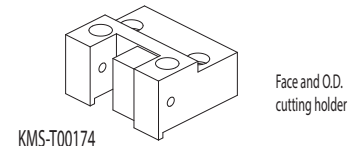
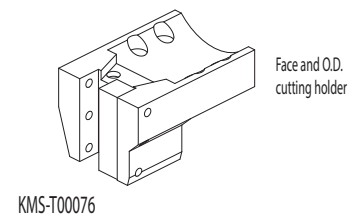
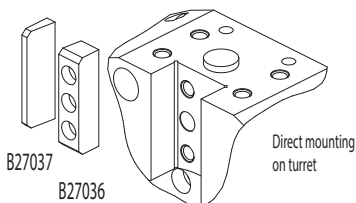

NEWS

Driven tools



124-00002 i.coolant
 124-00004 i.coolant

ACCESSORIES

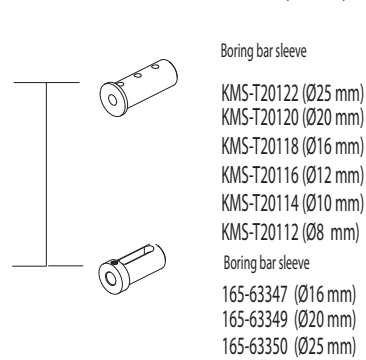
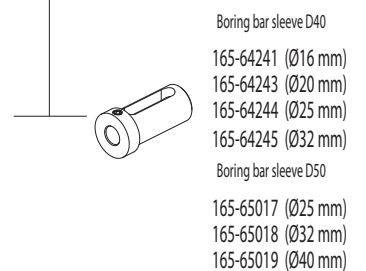
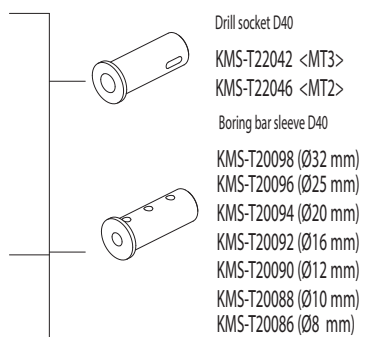

CONNECTION

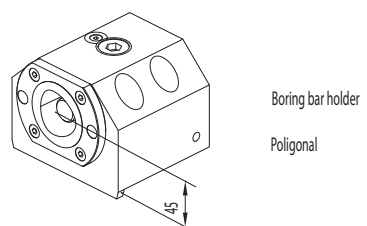
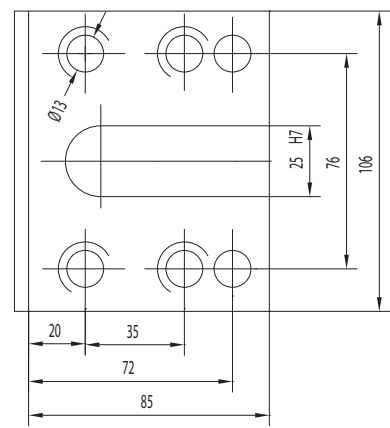



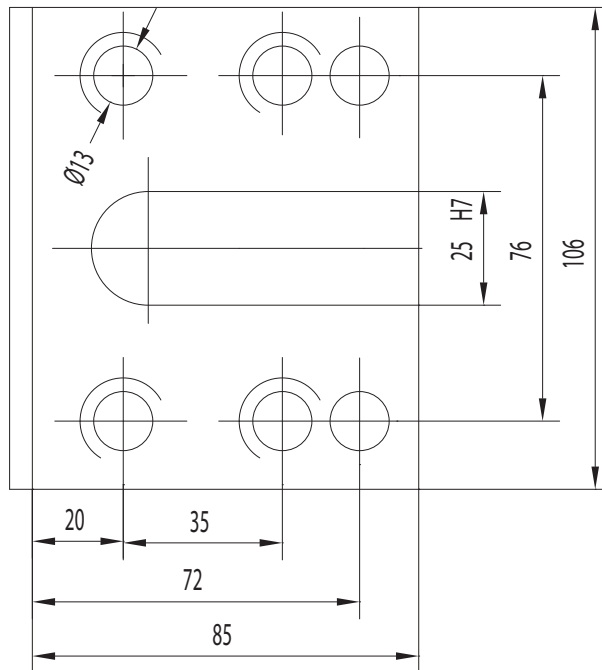

NEWS

CONNECTION

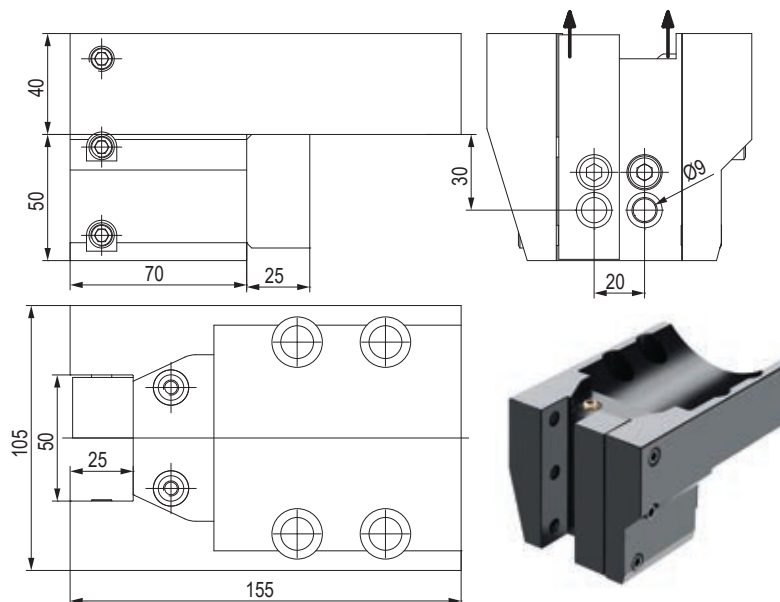

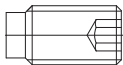
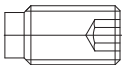
PORTAUTENSILE RADIALE - RADIAL TOOLHOLDERS

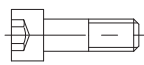

CODE N.	CLAMPING SCREW1 (M10X25)	CLAMPING SCREW2 (M10X16)	CLAMPING PLATE	COOLANT NOZZLE	SPACER	SCREW FOR SPACER
KMS-T00076						
	811-104030	811-104028	832-002117	833-001090	832-002116	811-101046

PORTAUTENSILE RADIALE - RADIAL TOOLHOLDERS

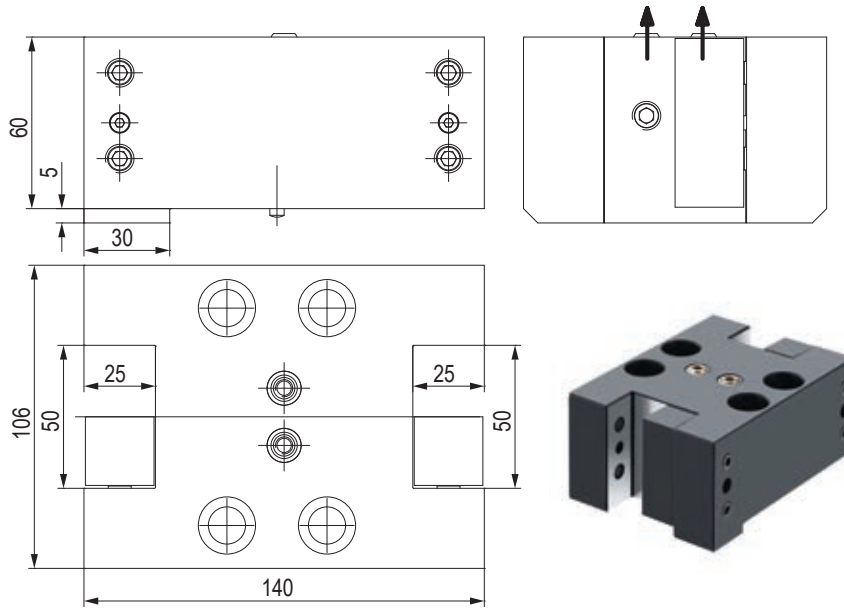

CODE N.	CLAMPING SCREW	CLAMPING PLATE	SCREW FOR CLAMPING PLATE	SPRING FOR CLAMPING PLATE	COOLANT NOZZLE	PIN
KMS-T00158	811-104030	832-002095	811-302004	824-101010	833-001110	815-220008

PORTAUTENSILE RADIALE - RADIAL TOOLHOLDERS

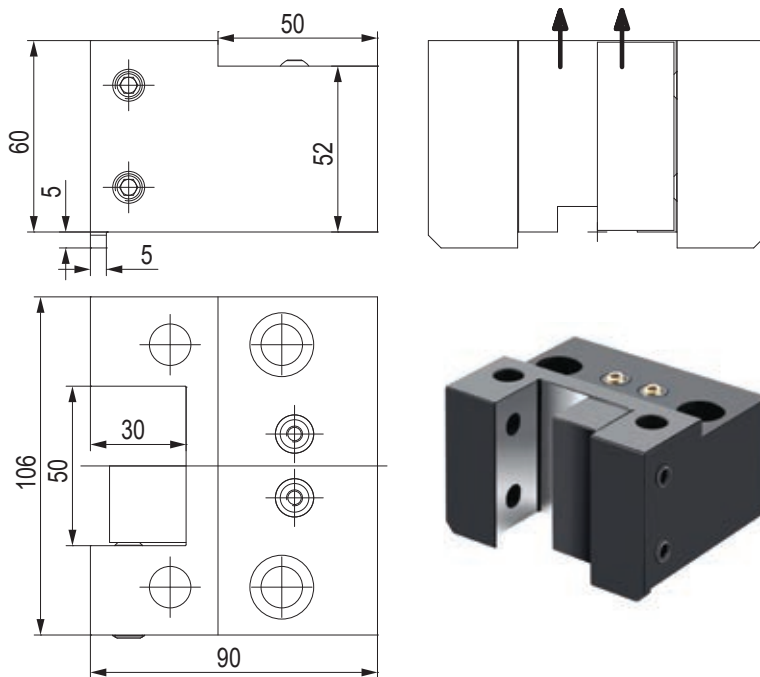

CODE N.	CLAMPING SCREW	CLAMPING PLATE	COOLANT NOZZLE
KMS-T00174	811-102040	832-002095	833-001080

PORTAUTENSILE ASSIALE - AXIAL TOOLHOLDERS

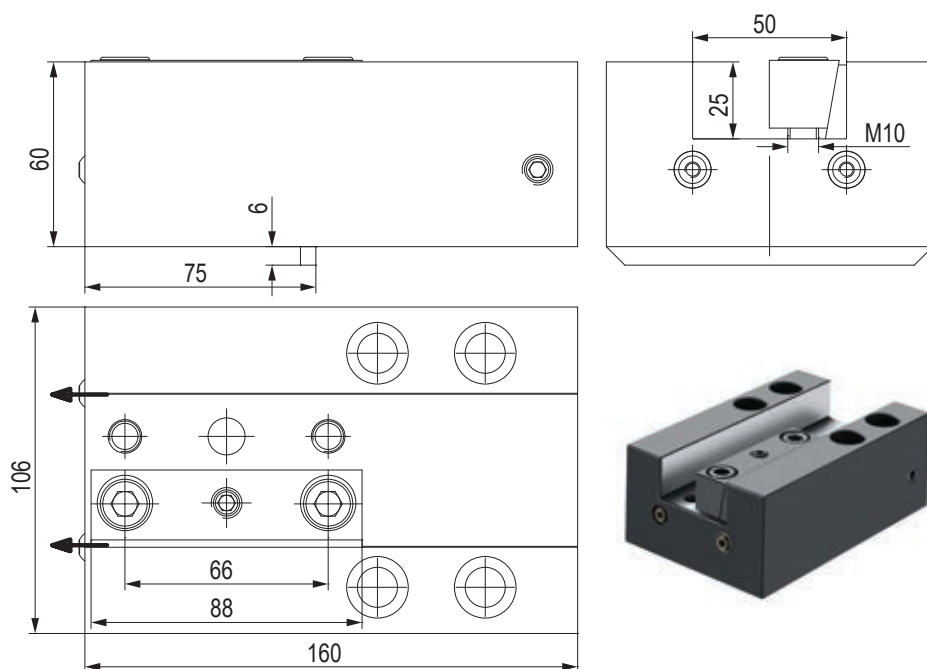

CODE N.	CLAMPING PLATE	COOLANT NOZZLE
KMS-T00082	832-007500	833-001080

PORTALAMA - CUT-OFF HOLDERS

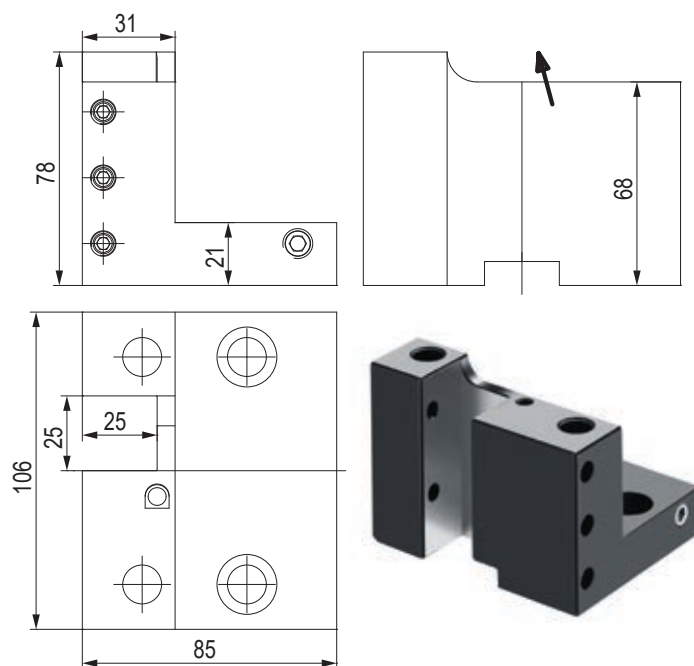

CODE N.	CLAMPING SCREW
KMS-T00156	811-104023

PORTAUTENSILE PER BARENI TOOLHOLDER FOR BORING BAR

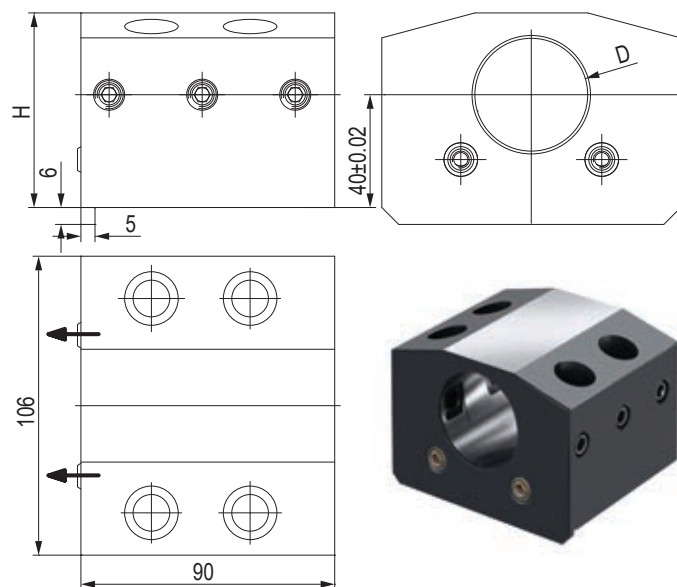

CODE N.	D	H	CLAMPING SCREW	COOLANT NOZZLE
KMS-T10036	40	69	811-102039	833-001110
KMS-T10044	50	74	811-102038	833-001110

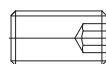

PORTAUTENSILE PER BARENI TOOLHOLDER FOR BORING BAR

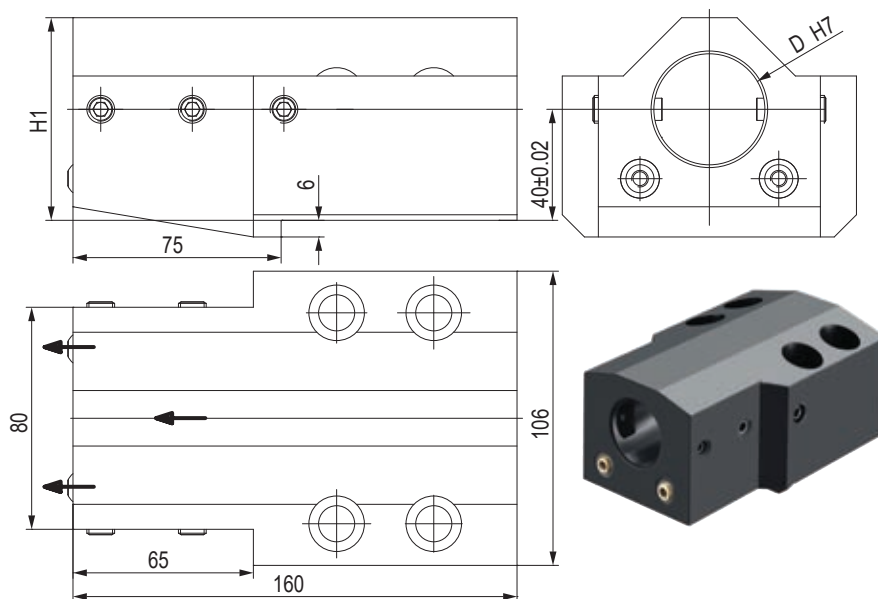

CODE N.	D	H1	CLAMPING SCREW	CLAMPING SCREW	COOLANT NOZZLE
KMS-T10038	40	73	811-104030	-	833-001090
128-22519	50	76	-	811-102043	833-001090

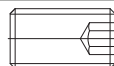

PORTAUTENSILE COMBINATO PER BARENI E PUNTE A INSERTI COMBI TOOLHOLDER FOR BORING BAR AND INSERTDRILL

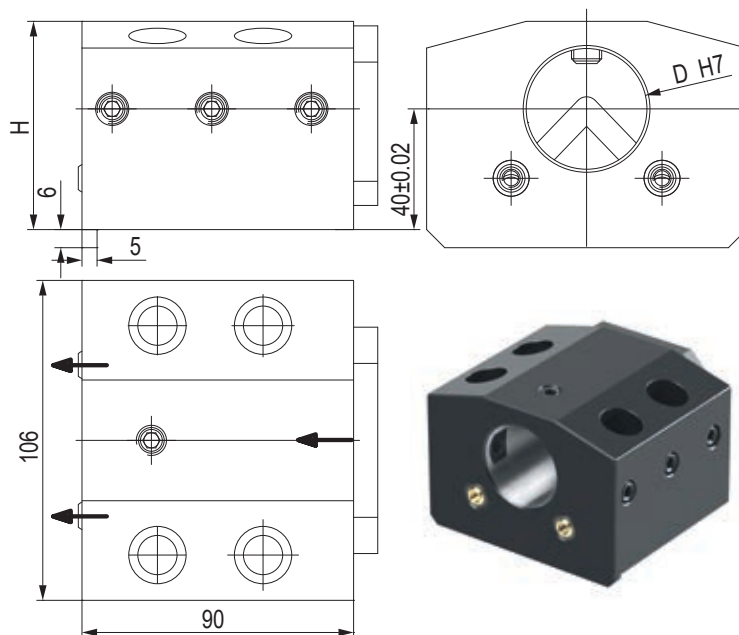

CODE N.	CLAMPING SCREW1 (M10X25)	CLAMPING SCREW2 (M10X14)	COOLANT NOZZLE	COVER	SCREW FOR COVER
KMS-T13064	811-102039	811-102060	833-001110	832-003063	811-101016

PORTAUTENSILE PER BARENI - TOOLHOLDER FOR BORING BAR

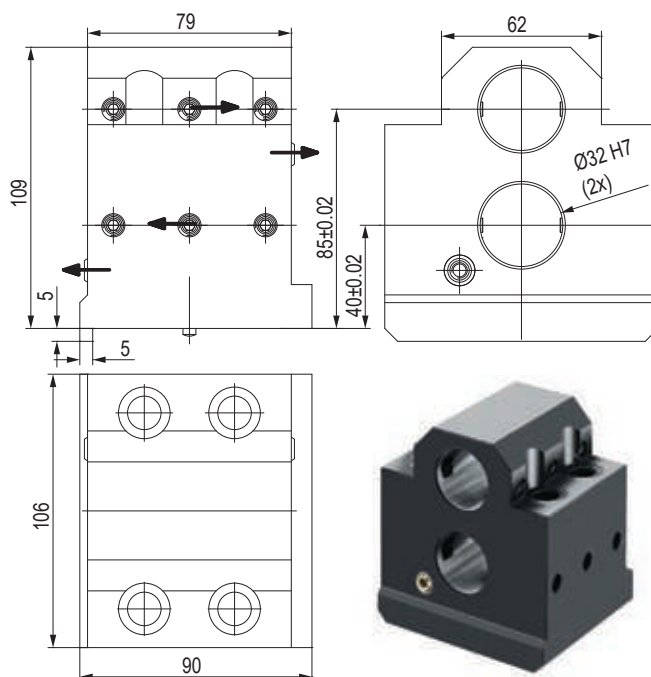

CODE N.	CLAMPING SCREW	COOLANT NOZZLE	PIN
KMS-T10086	811-104021	833-001110	815-210170

PORTAUTENSILE PER BARENI - TOOLHOLDER FOR BORING BAR

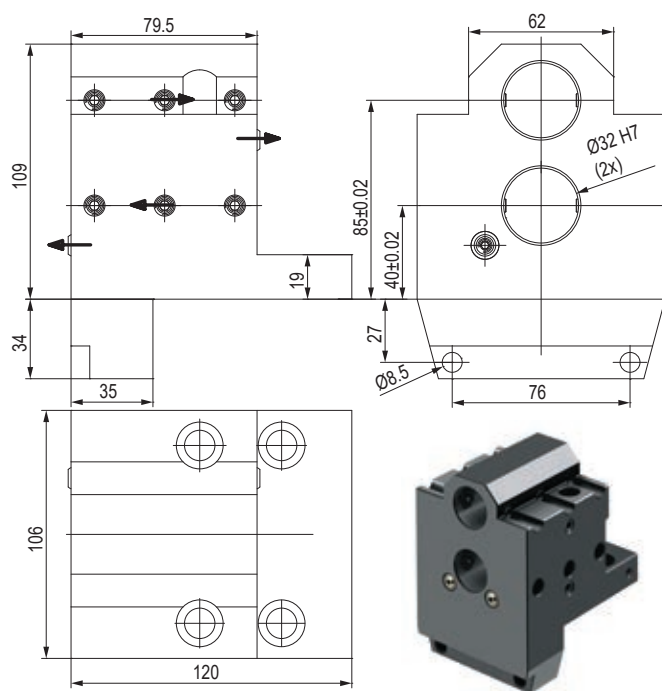

CODE N.	CLAMPING SCREW	COOLANT NOZZLE
KMS-T10208	811-104021	833-001110

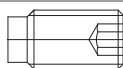

PORTAUTENSILE CON USCITA POLIGONALE POLIGONAL TOOLHOLDERS

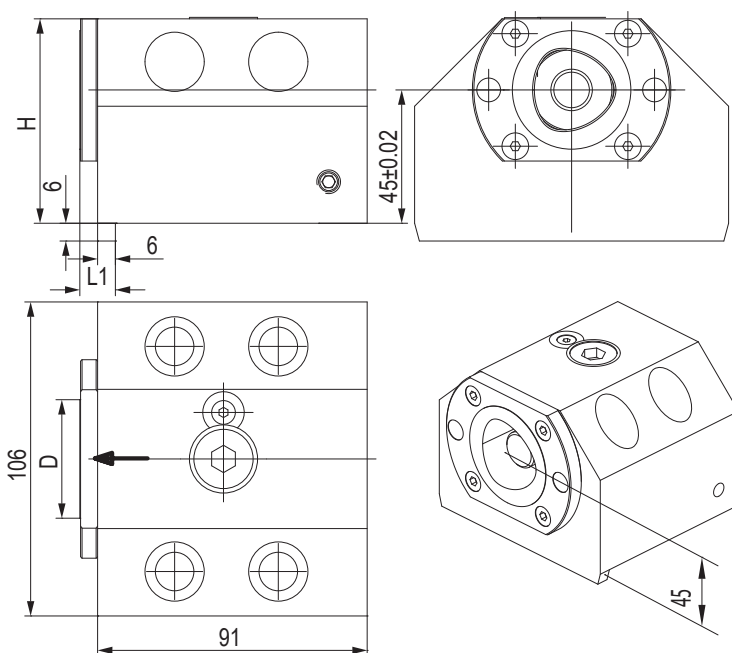

CODE N.	CAPTO	D	H	L1	CLAMPING UNIT
128-12526	C40	40	69	12	CXC40-10
128-12509	C50	50	77	14	CXC50-10

PORTAUTENSILE CON USCITA POLIGONALE POLIGONAL TOOLHOLDERS

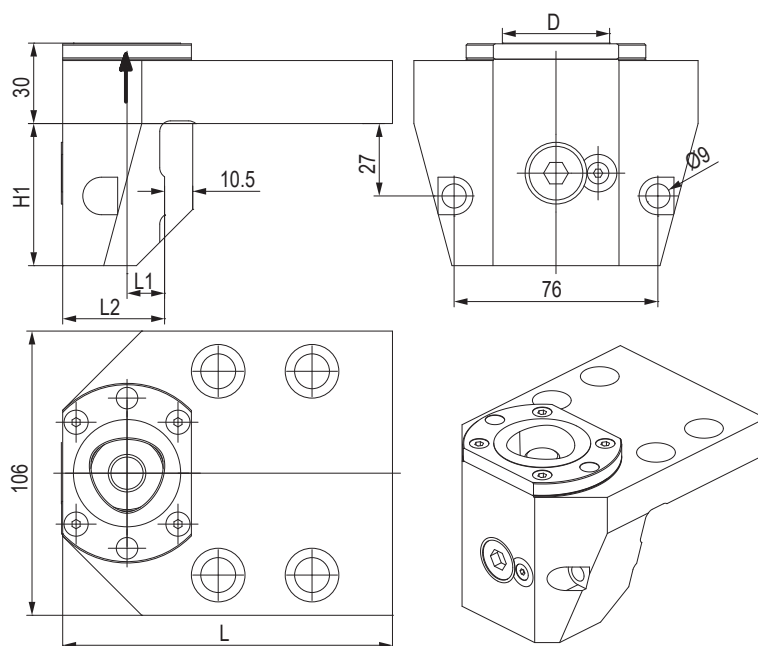

CODE N.	CAPTO	D	H1	L	L1	L2	CLAMPING UNIT
128-12527	C40	40	53	123	14	38	CXC40-10
128-12513	C50	50	65	139	22	54	CXC50-10

PORTAUTENSILE MOTORIZZATO ASSIALE STRAIGHT DRILLING AND MILLING HEAD

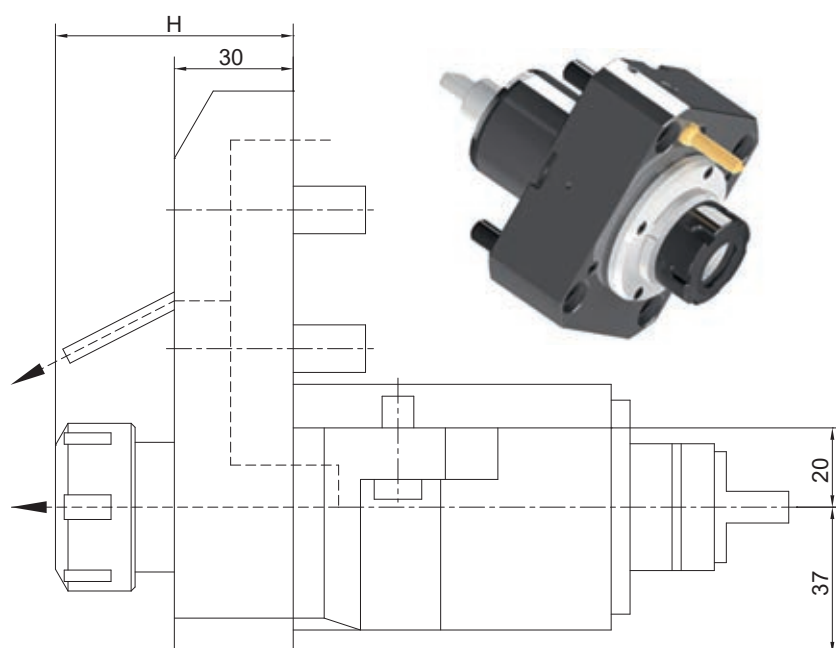

CODE N.	ER	H	MAX SPEED (Rpm)	I	MAX. TORQUE (Nm)	INTERNAL COOLING	P Bar
124-00001	ER32	55.5-60	6000	1:1	70	no	-
124-00002	ER32	55.5-60	6000	1:1	70	yes	80

PORTAUTENSILE MOTORIZZATO RADIALE ANGULAR DRILLING AND MILLING HEAD

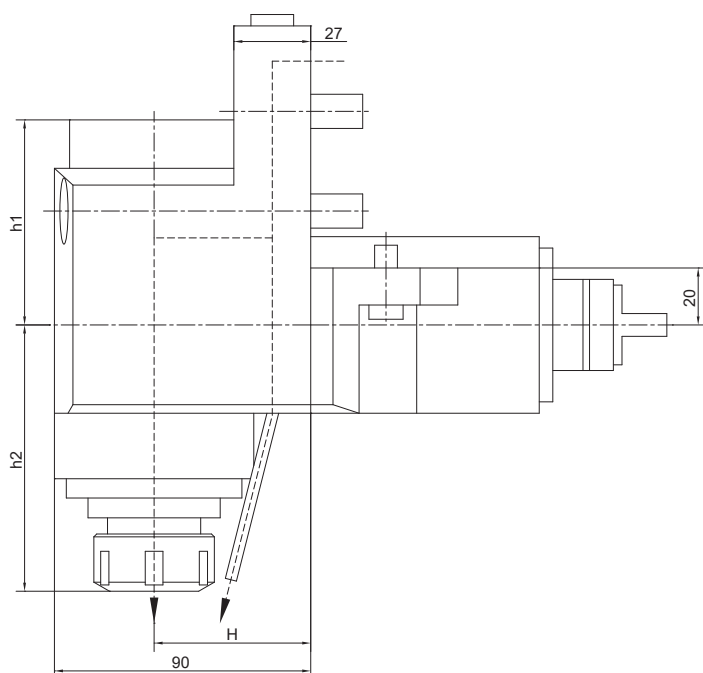

CODE N.	ER	H	h1	h2	MAX SPEED (Rpm)	I	MAX. TORQUE (Nm)	INTERNAL COOLING	P Bar
124-00003	ER32	55	57	89-93.5	6000	1:1	70	no	-
124-00004	ER32	55	72	89-93.5	6000	1:1	70	yes	80

BUSSOLA PER PORTABARENI DRILL SOCKET FOR TOOLHOLDER

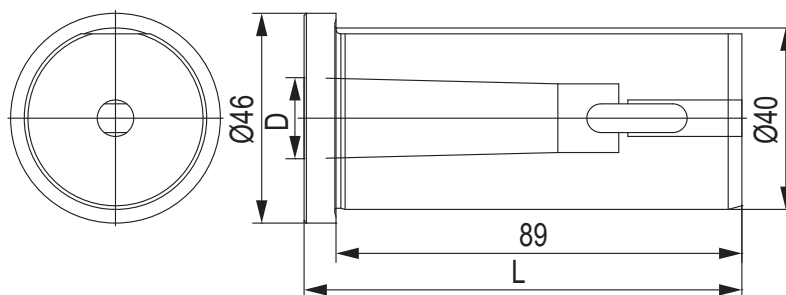

CODE N.	MORSE	D	H
KMS-T22042	3	23.825	108
KMS-T22046	2	17.78	96

BUSSOLA PER PORTABARENI BORING BAR SLEEVE FOR TOOLHOLDER

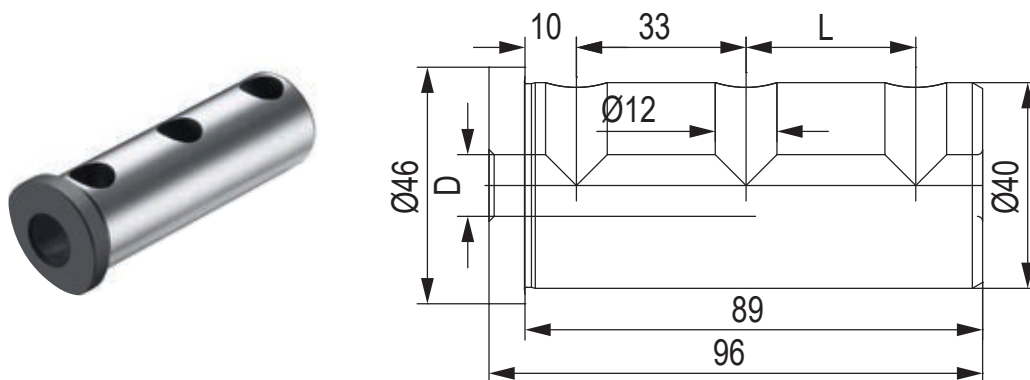

CODE N.	D	L
KMS-T20098	32	33
KMS-T20096	25	33
KMS-T20094	20	33
KMS-T20092	16	33
KMS-T20090	12	-
KMS-T20088	10	-
KMS-T20086	8	-

BUSSOLA PER PORTABARENI BORING BAR SLEEVE FOR TOOLHOLDER

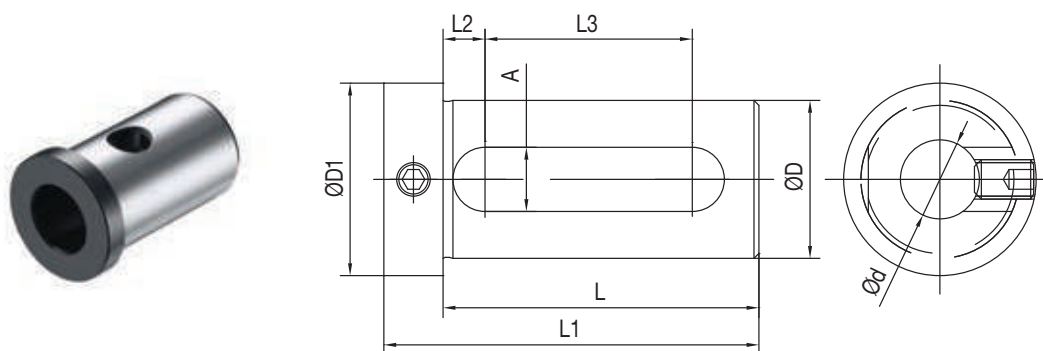

CODE N.	D	d	L	L1	L2	L3	A	D1
165-64241	40	16	74	88	9	51	14	48
165-64243	40	20	74	88	9	51	14	48
165-64244	40	25	74	88	9	51	14	48
165-64245	40	32	74	88	9	51	14	48
165-65017	50	25	84	98	9	61	14	59
165-65018	50	32	84	98	9	61	14	59
165-65019	50	40	84	98	9	61	14	59

BUSSOLA PER PORTABARENI BORING BAR SLEEVE FOR TOOLHOLDER

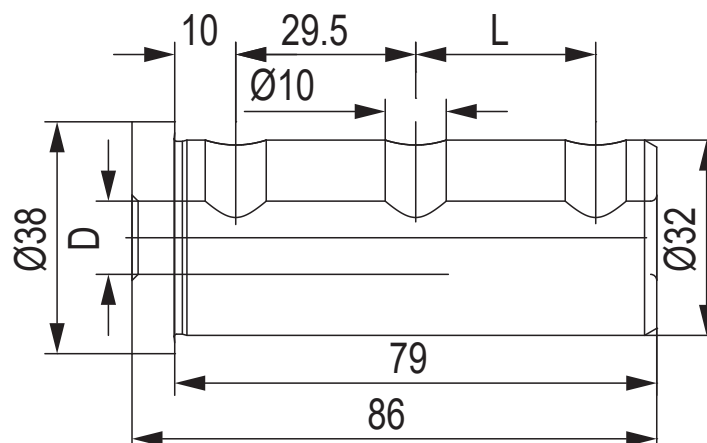

CODE N.	D	L
KMS-T20122	25	29.5
KMS-T20120	20	29.5
KMS-T20118	16	29.5
KMS-T20116	12	29.5
KMS-T20114	10	-
KMS-T20112	8	-

BUSSOLA PER PORTABARENI BORING BAR SLEEVE FOR TOOLHOLDER

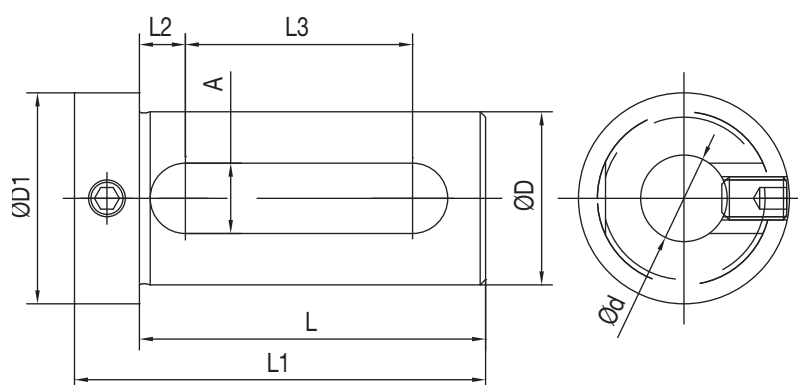

CODE N.	D	d	L	L1	L2	L3	A	D1
165-63347	32	16	64	76	8,5	42	13	39
165-63349	32	20	64	76	8,5	42	13	39
165-63350	32	25	64	76	8,5	42	13	39

DMG MORI

SL150
SL153
ZL150
CL150
SL154
SL153MC
ZL150MC
SL154MC

CMZ TL15

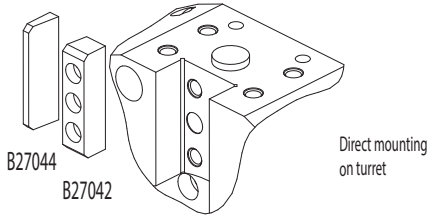

Direct mounting on turret

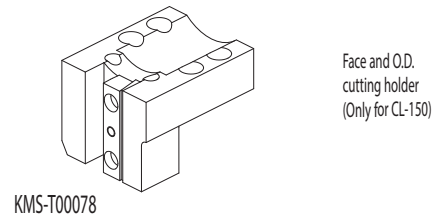

KMS-T00078

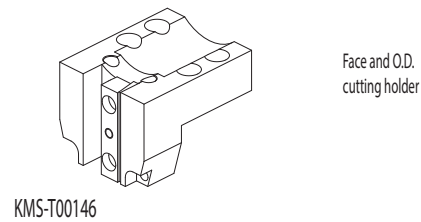

KMS-T00146

Qualified tool
20x20 mm

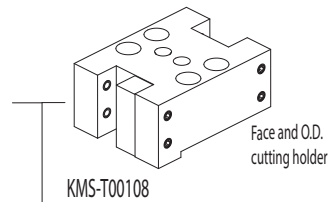

Face and O.D. cutting holder

KMS-T00108

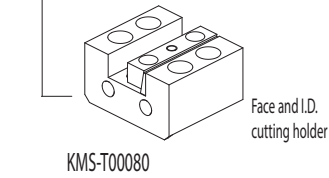

Face and I.D. cutting holder

KMS-T00080

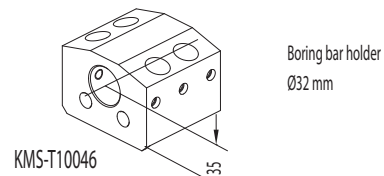

Boring bar holder
Ø32 mm

KMS-T10046

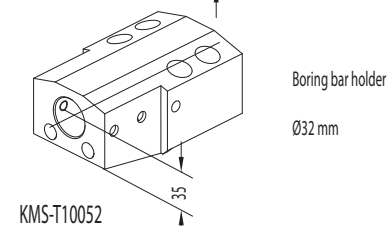

Boring bar holder
Ø32 mm

KMS-T10052

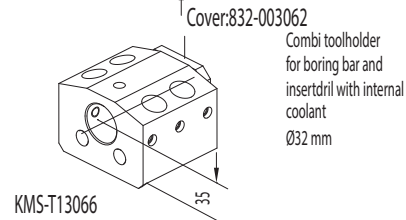

Combi toolholder for boring bar and insert drill with internal coolant
Ø32 mm

KMS-T13066

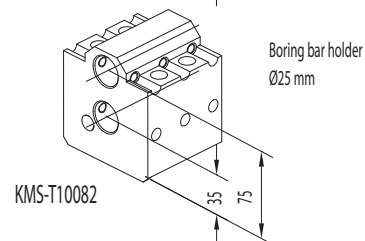

Boring bar holder
Ø25 mm

KMS-T10082

ACCESSORIES

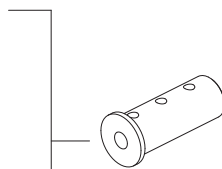

Boring bar sleeve

- KMS-T20122 (Ø25 mm)
- KMS-T20120 (Ø20 mm)
- KMS-T20118 (Ø16 mm)
- KMS-T20116 (Ø12 mm)
- KMS-T20114 (Ø10 mm)
- KMS-T20112 (Ø8 mm)

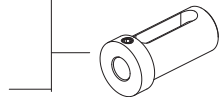

Boring bar sleeve

- 165-63347 (Ø16 mm)
- 165-63349 (Ø20 mm)
- 165-63350 (Ø25 mm)



Boring bar sleeve

- 165-62545 (Ø12 mm)
- 165-62547 (Ø16 mm)
- 165-62549 (Ø20 mm)

CONNECTION

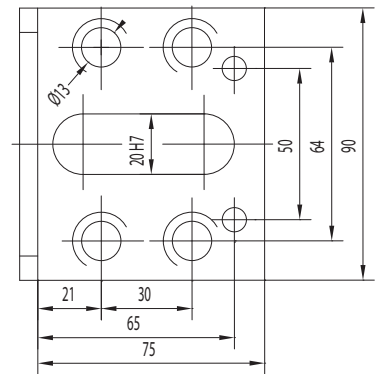

CONNECTION

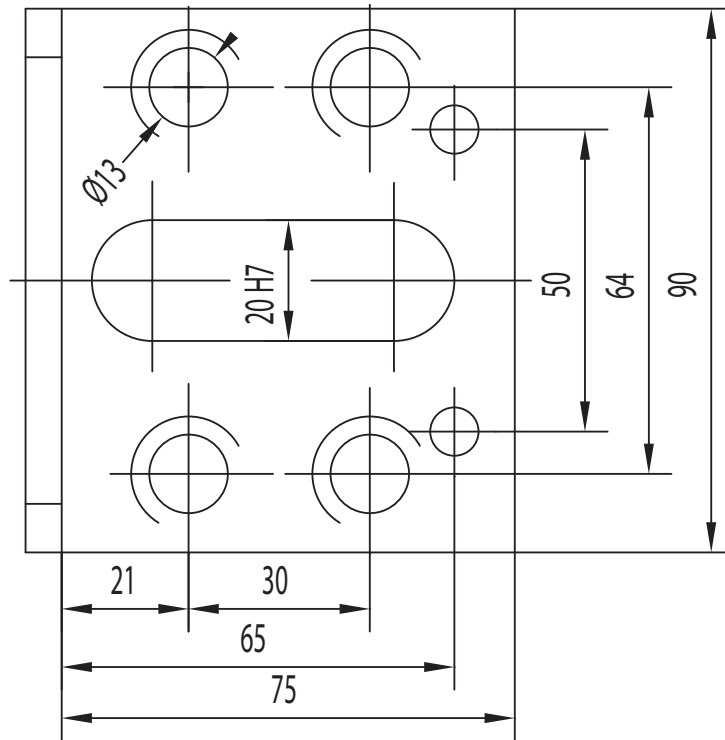

PORTAUTENSILE RADIALE - RADIAL TOOLHOLDERS

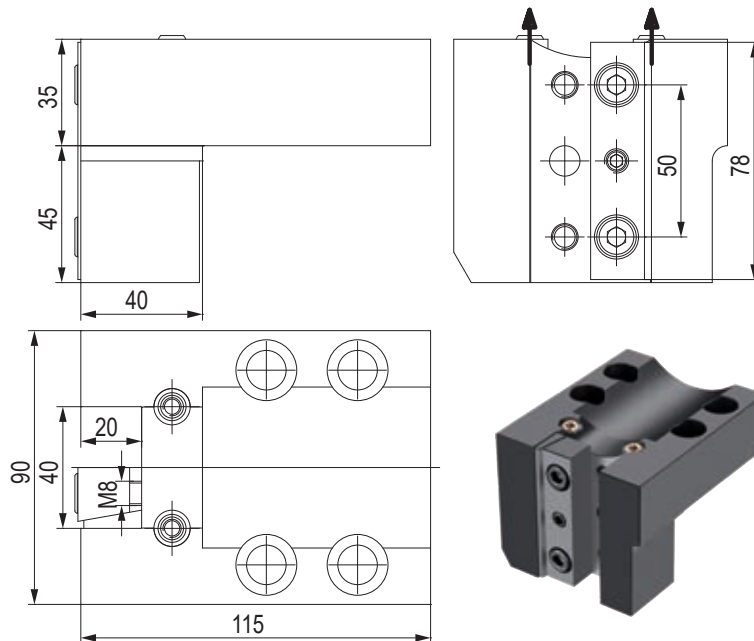

CODE N.	CLAMPING PLATE	COOLANT NOZZLE
KMS-T00078	832-007200	833-001110

PORTAUTENSILE RADIALE - RADIAL TOOLHOLDERS

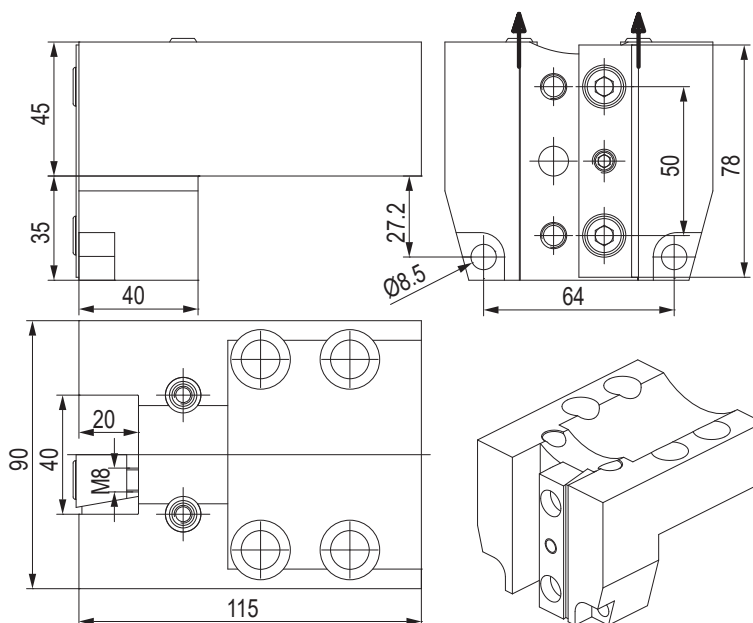

CODE N.	CLAMPING PLATE	COOLANT NOZZLE
KMS-T00146	832-007200	833-001110

PORTAUTENSILE RADIALE - RADIAL TOOLHOLDERS

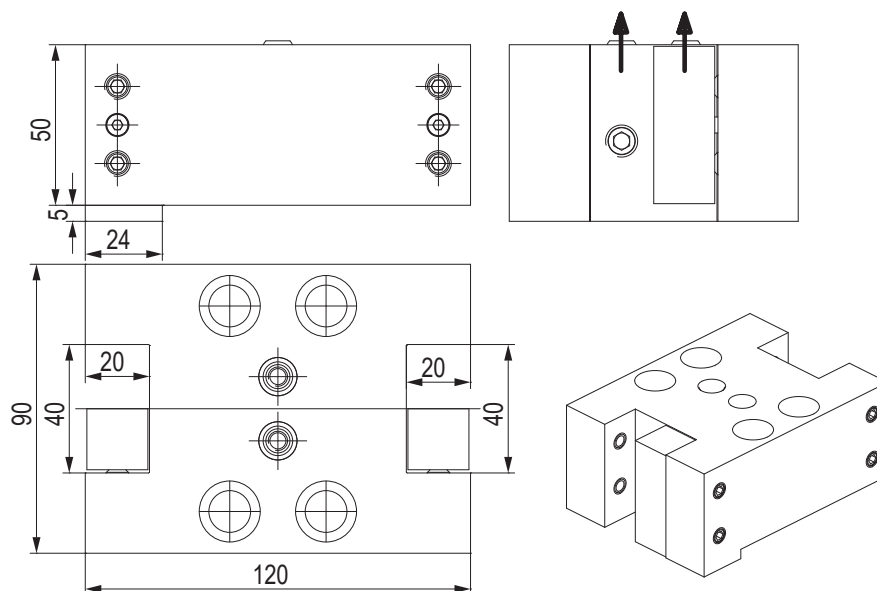

CODE N.	CLAMPING SCREW	CLAMPING PLATE	SPRING FOR CLAMPING PLATE	SCREW FOR CLAMPING PLATE	COOLANT NOZZLE
KMS-T00108	811-102031	832-002096	824-101010	811-302004	833-001110

PORTAUTENSILE ASSIALE - AXIAL TOOLHOLDERS

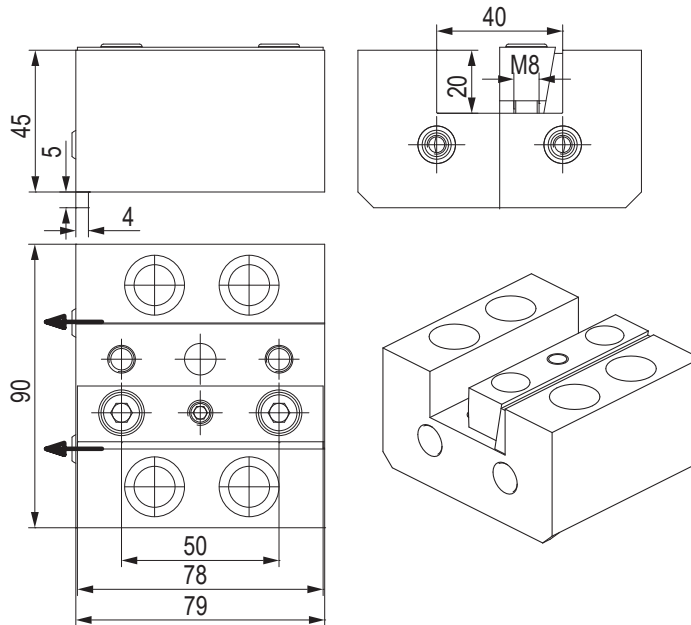

CODE N.	CLAMPING PLATE	COOLANT NOZZLE
KMS-T00080	832-007200	833-001110

12

PORTAUTENSILE PER BARENI TOOLHOLDER FOR BORING BAR

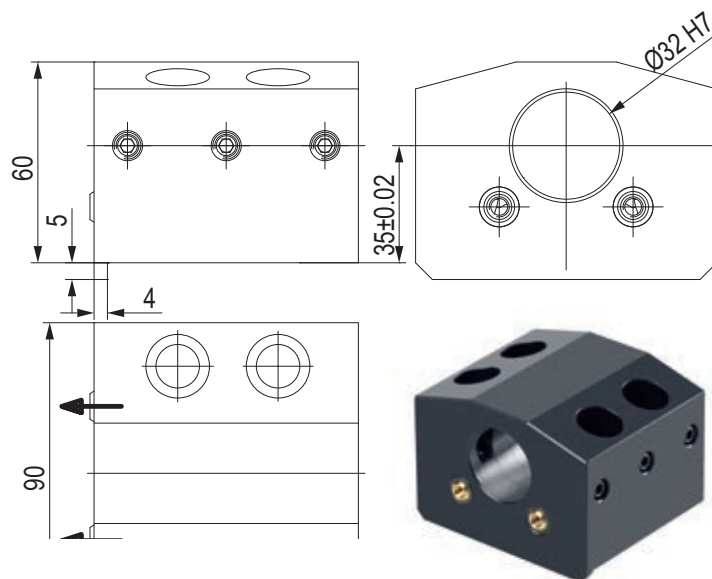

CODE N.	CLAMPING PLATE	COOLANT NOZZLE
KMS-T10046	811-102031	833-001110

PORTAUTENSILE PER BARENI TOOLHOLDER FOR BORING BAR

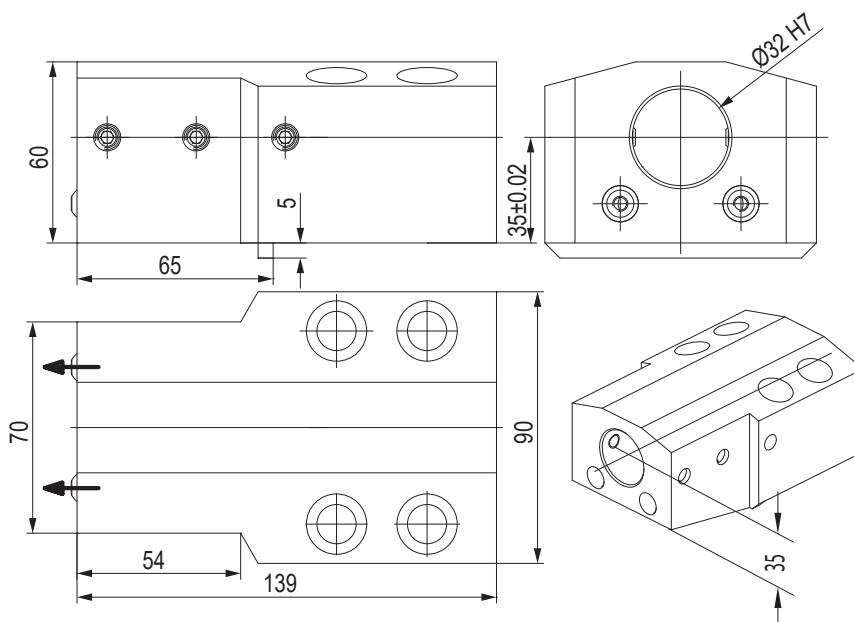

CODE N.	CLAMPING PLATE	COOLANT NOZZLE
KMS-T10052	811-102030	833-001080

PORTAUTENSILE COMBINATO PER BARENI E PUNTE A INSERTI COMBI TOOLHOLDER FOR BORING BAR AND INSERTDRILL

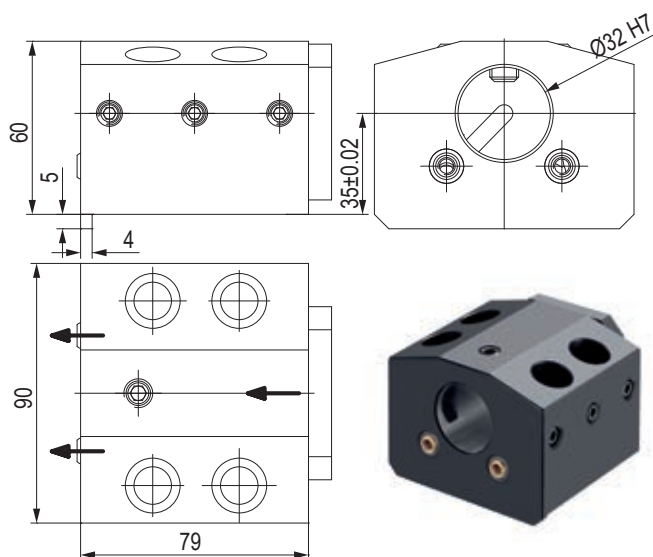

CODE N.	CLAMPING SCREW 1 (M8X25)	CLAMPING SCREW 2 (M10X14)	COOLANT NOZZLE	COVER	SCREW FOR COVER
KMS-T13066	811-102031	811-102060	833-001110	832-003062	811-101016

PORTAUTENSILE PER BARENI TOOLHOLDER FOR BORING BAR

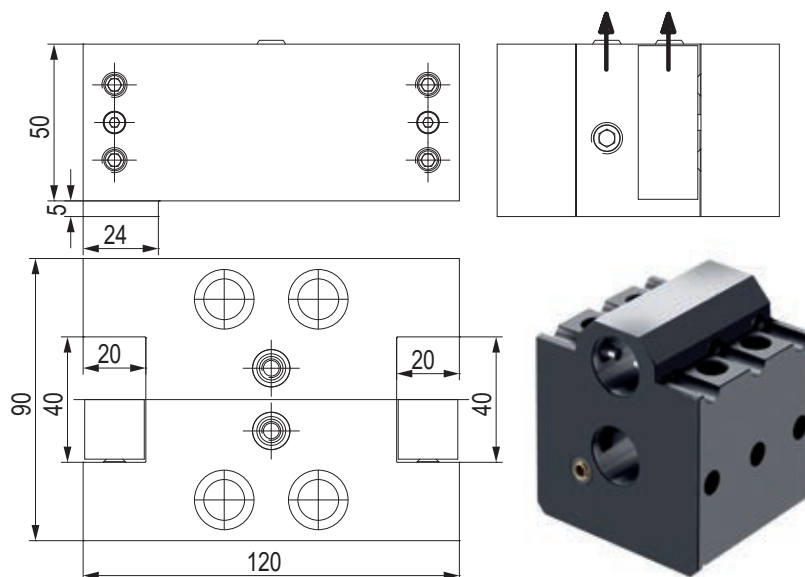

CODE N.	CLAMPING SCREW	COOLANT NOZZLE
KMS-T10082	811-104021	833-001110

BUSSOLA PER PORTABARENI BORING BAR SLEEVE FOR TOOLHOLDER

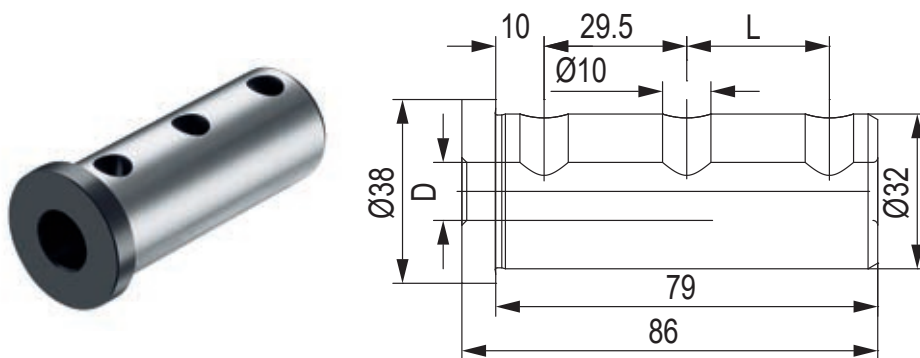

CODE N.	D	L
KMS-T20122	25	29.5
KMS-T20120	20	29.5
KMS-T20118	16	29.5
KMS-T20116	12	29.5
KMS-T20114	10	-
KMS-T20112	8	-

BUSSOLA PER PORTABARENI BORING BAR SLEEVE FOR TOOLHOLDER

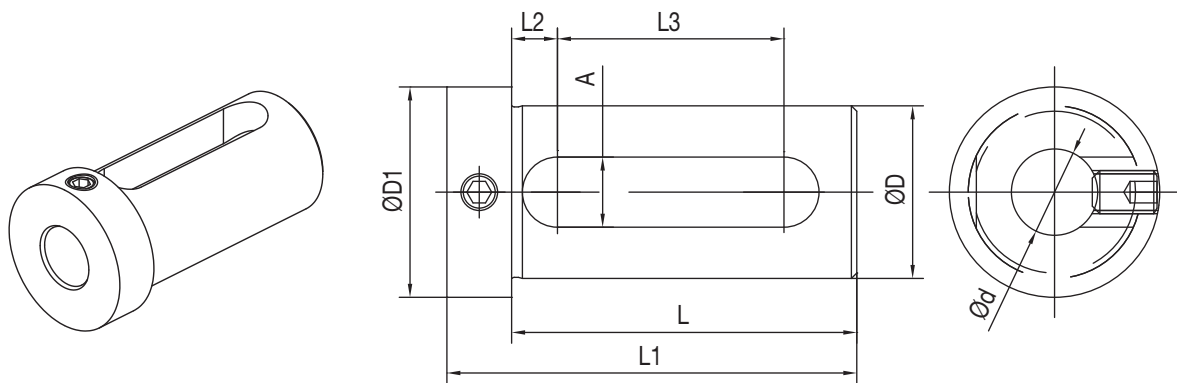

CODE N.	D	d	L	L1	L2	L3	A	D1	SCREW
165-62545	25	12	54	66	8,5	32	13	32	811-102028
165-62547	25	16	54	66	8,5	32	13	32	811-102027
165-62549	25	20	54	66	8,5	32	13	32	811-102027
165-63347	32	16	64	76	8,5	42	13	39	-
165-63349	32	20	64	76	8,5	42	13	39	-
165-63350	32	25	64	76	8,5	42	13	39	-

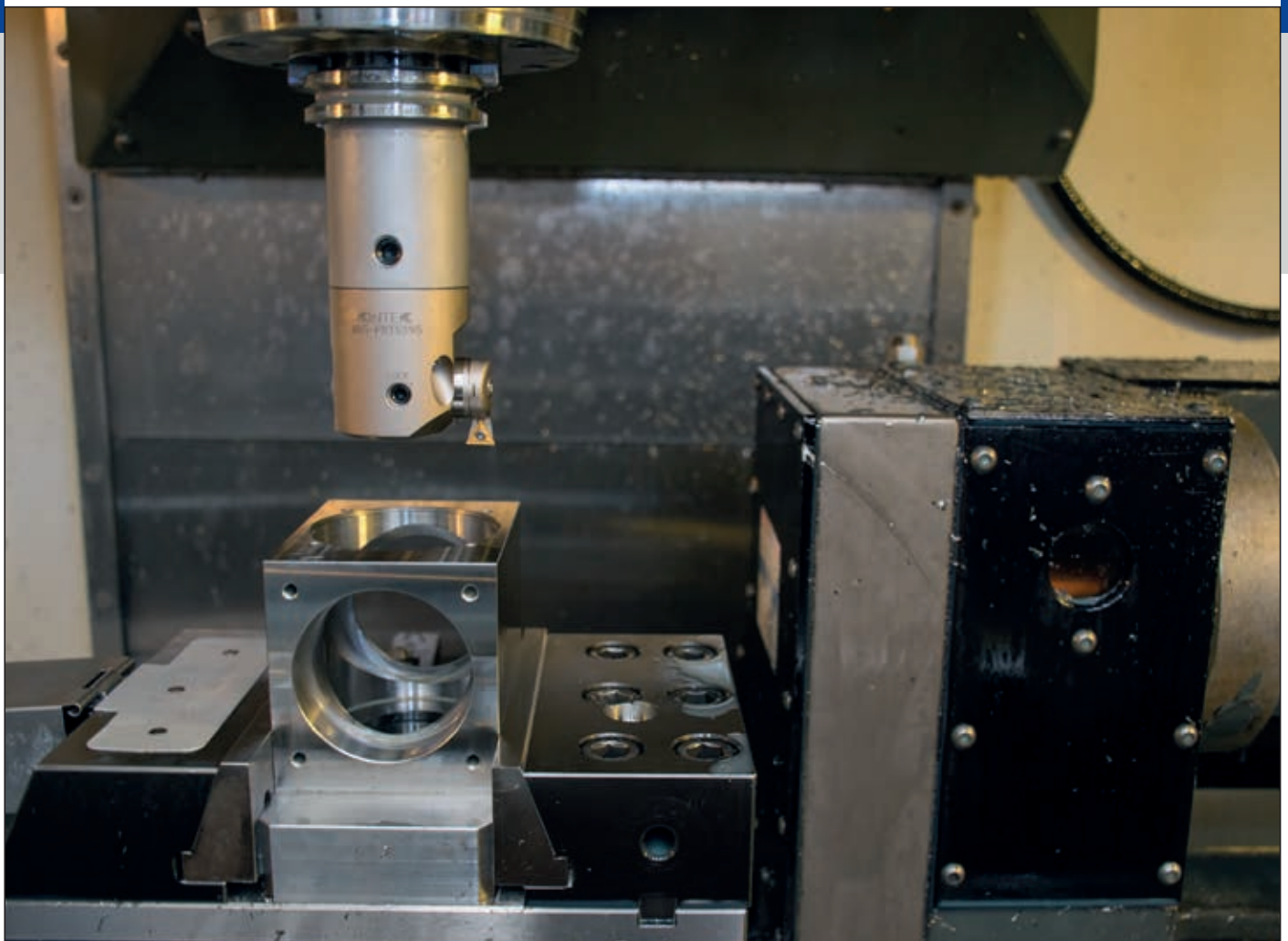
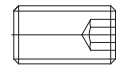

DMG MORI

CL 200/203
SL 20/25
SL 200/203/204/250
253/254 (MC, SMD) - 2500Y
ZL/DL 200/250 (MC)
DURATURN 2030
DURATURN 2050
DURATURN 2550

GOODWAY

GS 200/260/280
GA 2000/2600
GA 2800/3000
GA 3300/3600

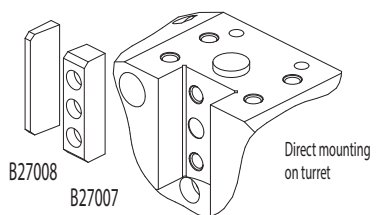

B27008
B27007

Direct mounting
on turret

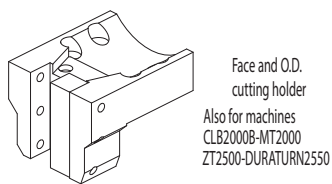

KMS-T00074

Face and O.D.
cutting holder
Also for machines
CLB2000B-MT2000
ZT2500-DURATURN2550

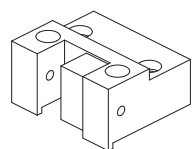

KMS-T00174

Face and O.D.
cutting holder

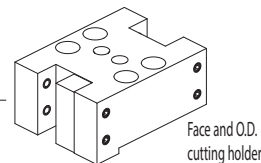

KMS-T00158

Face and O.D.
cutting holder

Qualified tool
25x25 mm

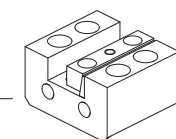

KMS-T00068

Face and I.D.
cutting holder
Suitable also for machines
CLB2000B-MT2000
ZT2500-DURATURN2550

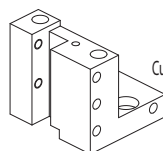

KMS-T00156

Cut-off holder

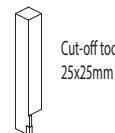

Cut-off tool
25x25mm

Suitable also for machines
CLB2000B-MT2000
ZT2500-DURATURN2550

CONNECTION

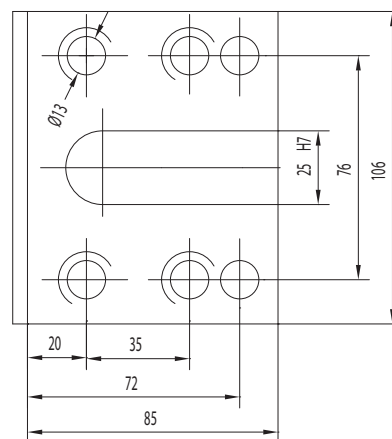

ACCESSORIES

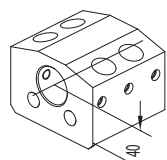

Boring bar holder

KMS-T10036 (Ø40 mm)
KMS-T10044 (Ø50 mm)

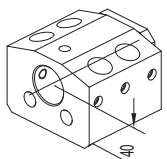

Combi toolholder
for boring bar and
insert drill with internal
coolant

KMS-T13064 (Ø40 mm)
128-22540 (Ø50 mm)

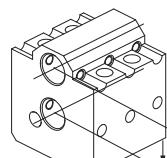

KMS-T10086

Boring bar holder

Ø32 mm

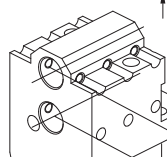

KMS-T10208

Boring bar holder

Ø32 mm

D40

Drill socket

KMS-T22042 <MT3>
KMS-T22046 <MT2>

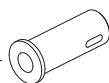

Boring bar sleeve

KMS-T20098 (Ø32 mm)
KMS-T20096 (Ø25 mm)
KMS-T20094 (Ø20 mm)
KMS-T20092 (Ø16 mm)
KMS-T20090 (Ø12 mm)
KMS-T20088 (Ø10 mm)
KMS-T20086 (Ø8 mm)

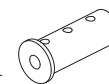

Boring bar sleeve

165-64241 (Ø16 mm)
165-64243 (Ø20 mm)
165-64244 (Ø25 mm)
165-64245 (Ø32 mm)

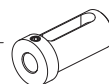

Boring bar sleeve

KMS-T20122 (Ø25 mm)
KMS-T20120 (Ø20 mm)
KMS-T20118 (Ø16 mm)
KMS-T20116 (Ø12 mm)
KMS-T20114 (Ø10 mm)
KMS-T20112 (Ø8 mm)

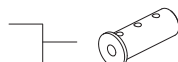

Boring bar sleeve

165-63347 (Ø16 mm)
165-63349 (Ø20 mm)
165-63350 (Ø25 mm)



D50

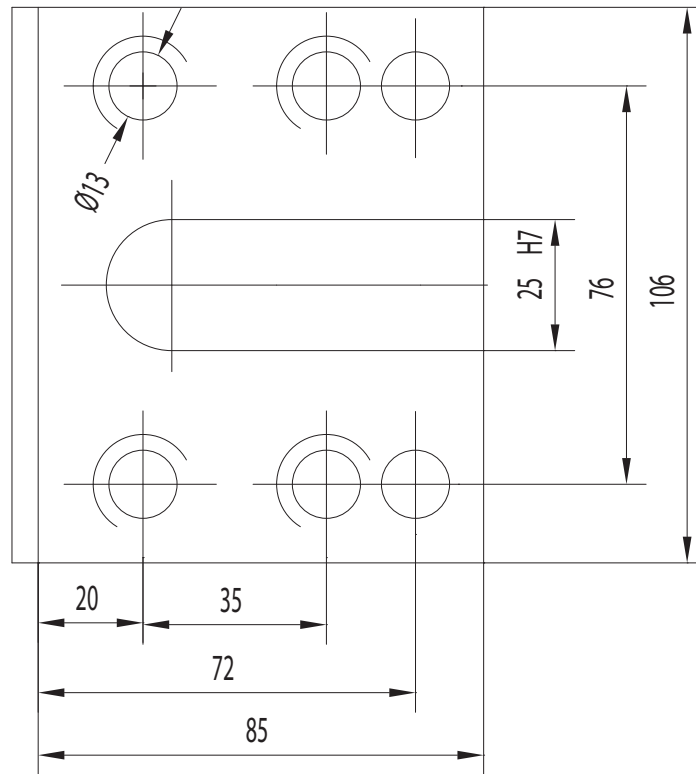

165-65017 (Ø25 mm)
165-65018 (Ø32 mm)
165-65019 (Ø40 mm)

CONNECTION

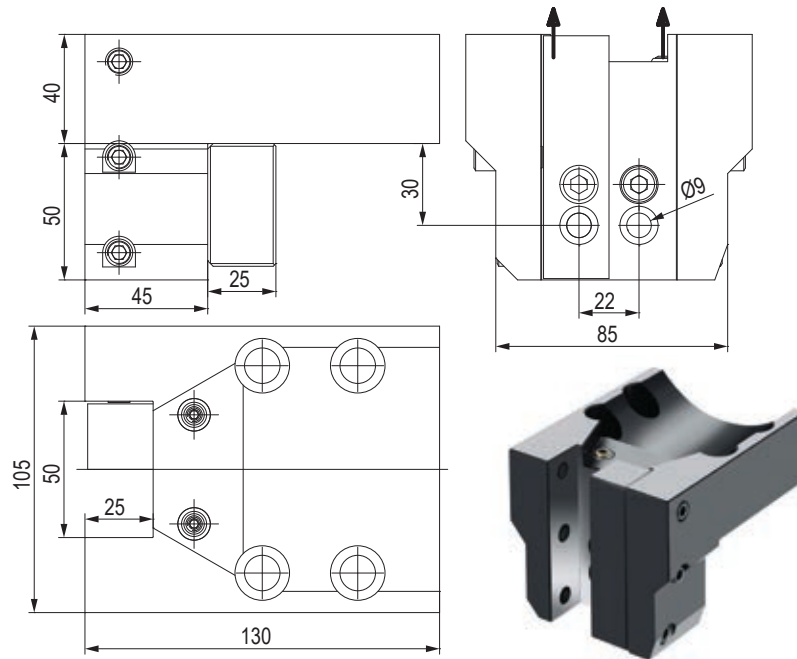

PORTAUTENSILE RADIALE - RADIAL TOOLHOLDERS

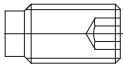
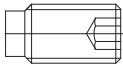

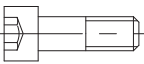
CODE N.	CLAMPINGSCREW 1 (M10X25)	CLAMPING SCREW 2 (M10X16)	CLAMPING PLATE	COOLANT NOZZLE	SPACER	SCREW FOR SPACER
KMS-T00074						
	811-104030	811-104028	832-002117	833-001110	832-002132	811-101041

PORTAUTENSILE RADIALE - RADIAL TOOLHOLDERS

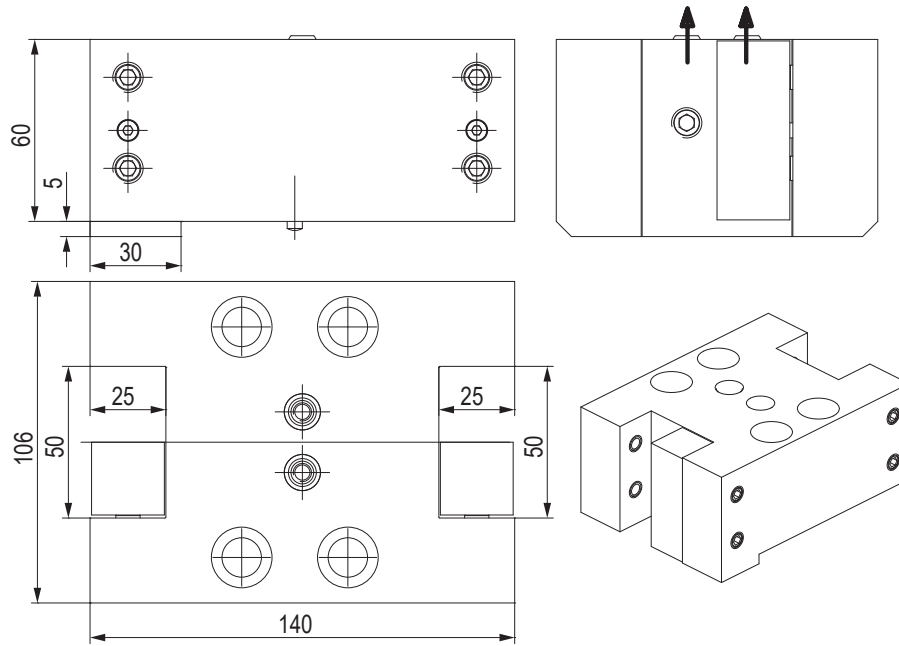

CODE N.	CLAMPING SCREW	CLAMPING PLATE	SCREW FOR CLAMPING PLATE	SPRING FOR CLAMPING PLATE	COOLANT NOZZLE	PIN
KMS-T00158	811-104030	832-002095	811-302004	824-101010	833-001110	815-220008

PORTAUTENSILE RADIALE - RADIAL TOOLHOLDERS

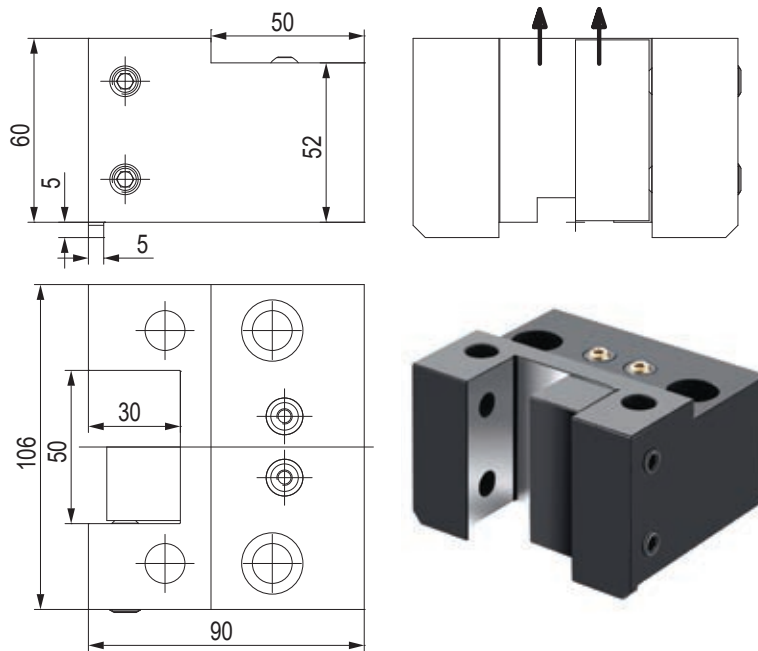

CODE N.	CLAMPING SCREW	CLAMPING PLATE	COOLANT NOZZLE
KMS-T00174	811-102040	832-002095	833-001080

PORTAUTENSILE ASSIALE - AXIAL TOOLHOLDERS

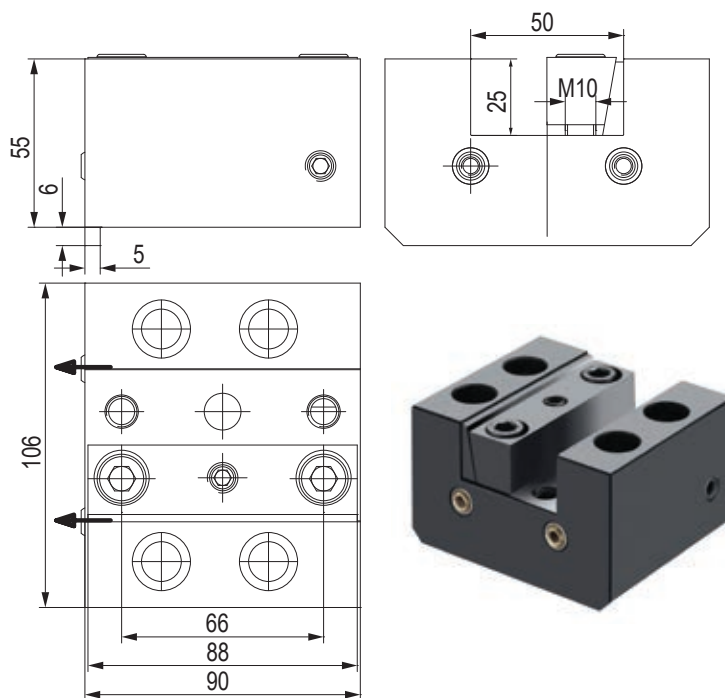

CODE N.	CLAMPING PLATE	COOLANT NOZZLE
KMS-T00068	832-007500	833-001110

PORTALAMA - CUT-OFF TOOLHOLDERS

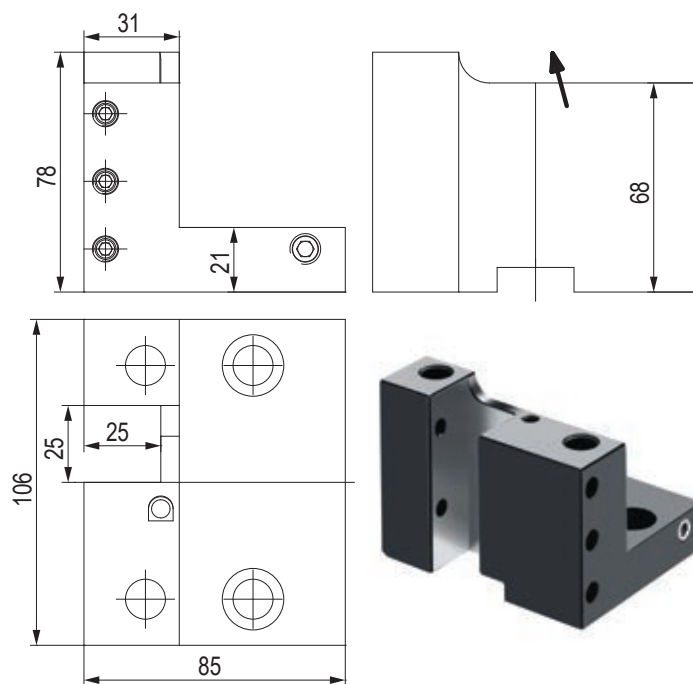

CODE N.	CLAMPING SCREW
KMS-T00156	811-104023

PORTAUTENSILE PER BARENI - TOOLHOLDER FOR BORING BAR

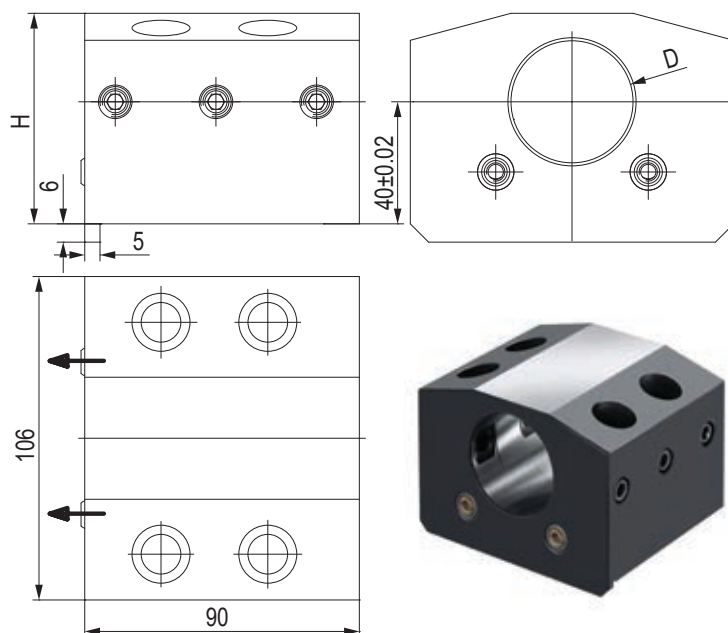

CODE N.	D	H	CLAMPING SCREW	COOLANT NOZZLE
KMS-T10036	40	69	811-102039	833-001110
KMS-T10044	50	74	811-102038	833-001110

PORTAUTENSILE COMBINATO PER BARENI E PUNTE A INSERTI COMBI TOOLHOLDER FOR BORING BAR AND INSERT DRILL

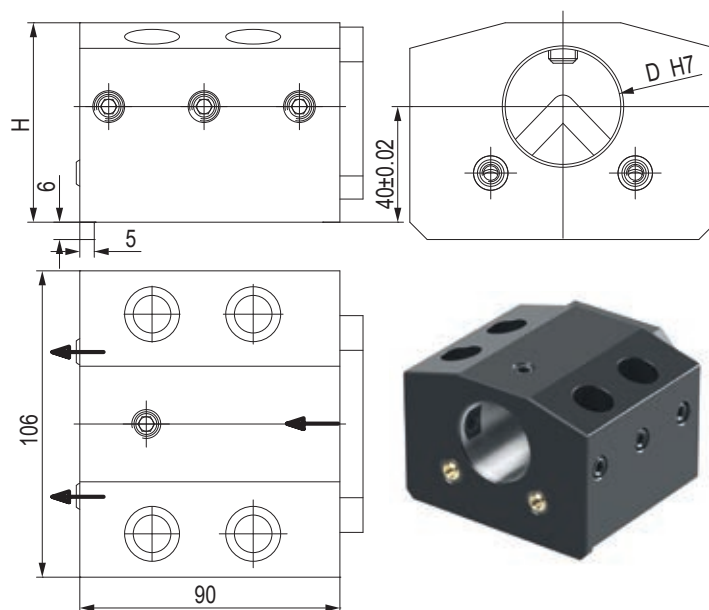

CODE N.	D	H	CLAMPING SCREW 1 (D40 M10X25) (D50 M10X20)	CLAMPING SCREW 2 (M10X14)	COOLANT NOZZLE	COVER	SCREW FOR COVER
KMS-T13064	40	69	811-102039	811-102060	833-001110	832-003063	811-101016
128-22540	50	74	811-102038	811-102060	833-001110	832-003321	811-101016

PORTAUTENSILE PER BARENI - TOOLHOLDER FOR BORING

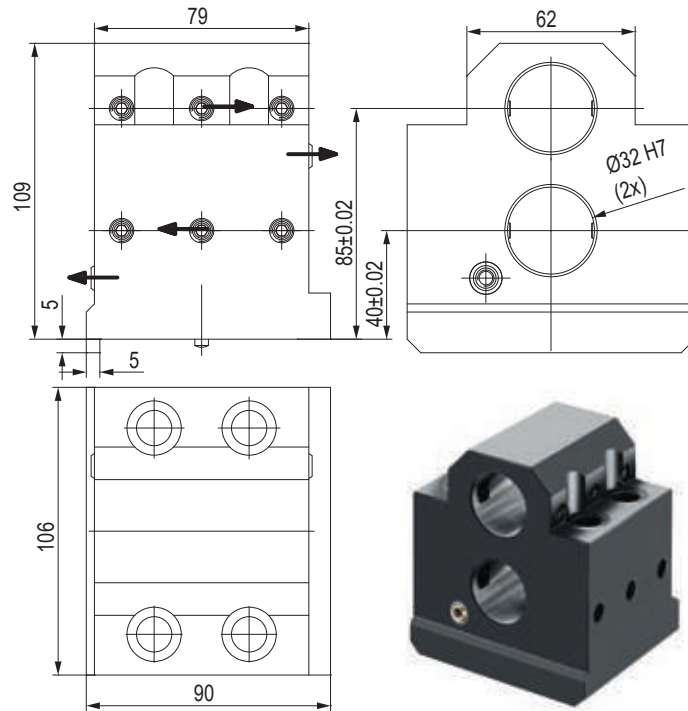

CODE N.	CLAMPING SCREW	COOLANT NOZZLE	PIN
KMS-T10086	811-104021	833-001110	815-210170

PORTAUTENSILE PER BARENI - TOOLHOLDER FOR BORING

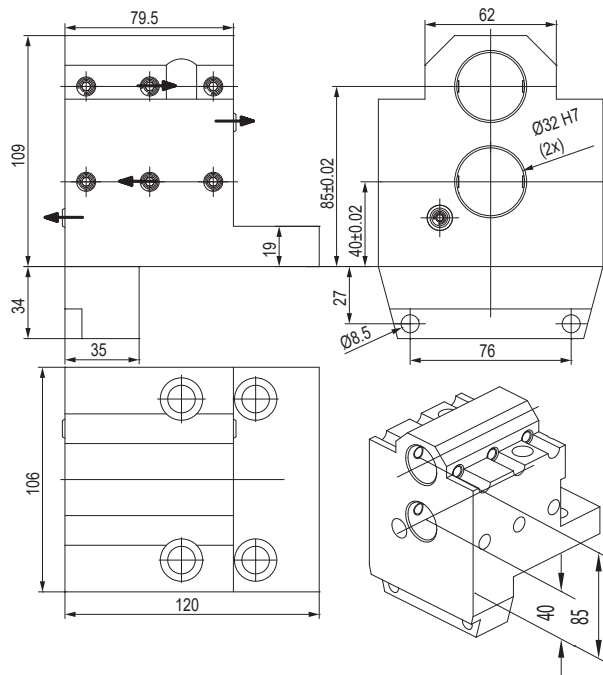

CODE N.	CLAMPING SCREW	COOLANT NOZZLE
KMS-T10208	811-104021	833-001110

BUSSOLA PER PORTABARENI DRILL SOCKET FOR TOOLHOLDER

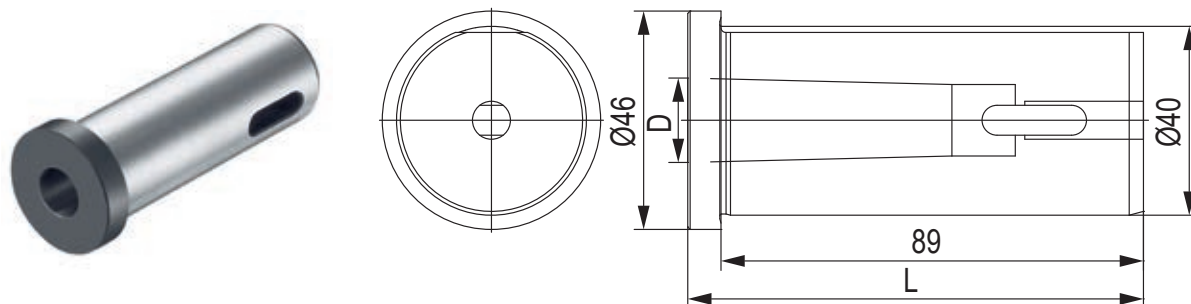

CODE N.	MORSE	D	H
KMS-T22042	3	23.825	108
KMS-T22046	2	17.78	96

PORTAUTENSILE PER BARENI - TOOLHOLDER FOR BORING

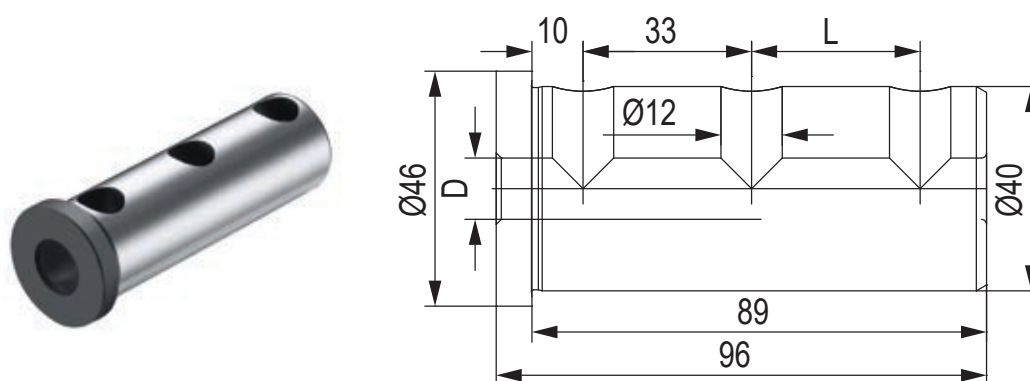

CODE N.	D	L
KMS-T20098	32	33
KMS-T20096	25	33
KMS-T20094	20	33
KMS-T20092	16	33
KMS-T20090	12	-
KMS-T20088	10	-
KMS-T20086	8	-

BUSSOLA PER PORTABARENI BORING BAR SLEEVE FOR TOOLHOLDER

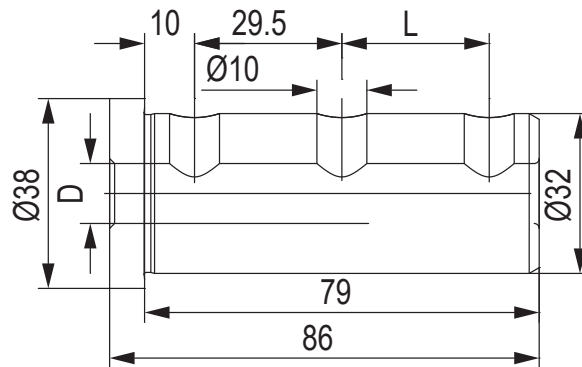

CODE N.	D	L
KMS-T20122	25	29.5
KMS-T20120	20	29.5
KMS-T20118	16	29.5
KMS-T20116	12	29.5
KMS-T20114	10	-
KMS-T20112	8	-



BUSSOLA PER PORTABARENI BORING BAR SLEEVE FOR TOOLHOLDER

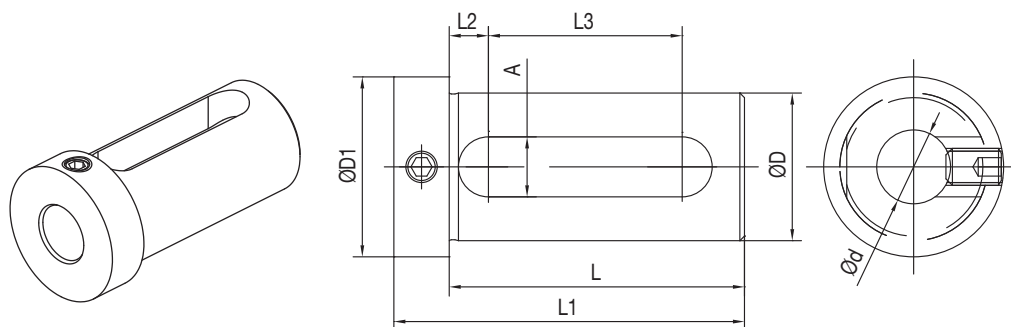

CODE N.	D	d	L	L1	L2	L3	A	D1
165-63347	32	16	65	77	8	42	13	39
165-63349	32	20	65	77	8	42	13	39
165-63350	32	25	65	77	8	42	13	39
165-64241	40	16	75	89	9	51	14	48
165-64243	40	20	75	89	9	51	14	48
165-64244	40	25	75	89	9	51	14	48
165-64245	40	32	75	89	9	51	14	48
165-65017	50	25	85	99	9	61	14	60
165-65018	50	32	85	99	9	61	14	60
165-65019	50	40	85	99	9	61	14	60

12

KINTEK®

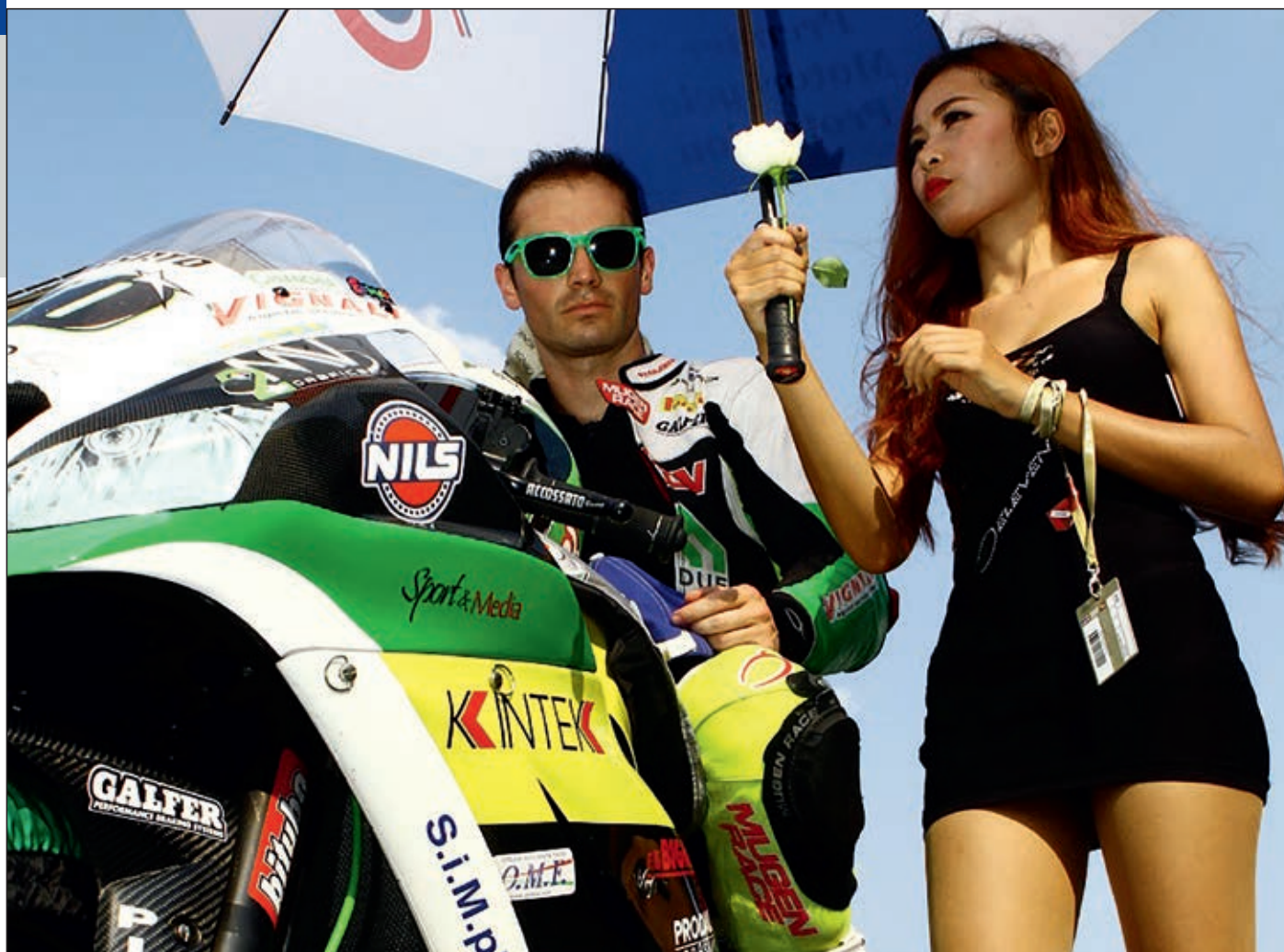

OKUMA
(VDI30)

LT10M
LT200M
LB10

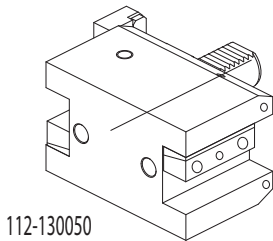

112-130050

Face and I.D.
cutting holder

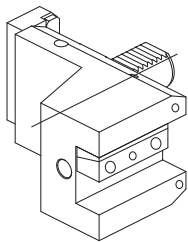

112-330080

Face and I.D.
cutting holder

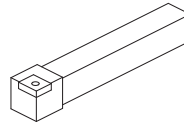

Qualified tool
20x20 mm

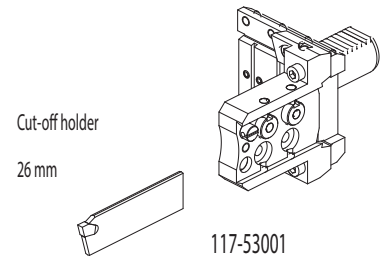

Cut-off holder

26 mm

117-53001

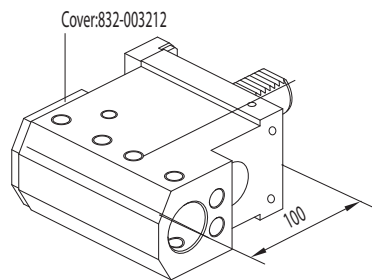

115-230450

Cover:832-003212

Combi toolholder
for boring bar and
insertdrill with internal
coolant

Ø32 mm

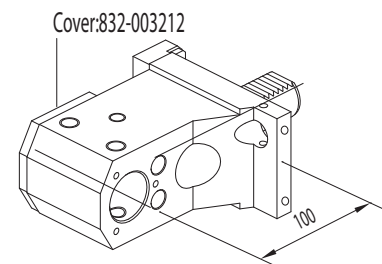

115-230460

Cover:832-003212

Combi toolholder
for boring bar and
insertdrill with internal
coolant

Ø32 mm

ACCESSORIES

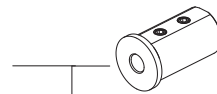

Boring bar sleeve

165-63352 (Ø8)

165-63353 (Ø10)

165-63354 (Ø12)

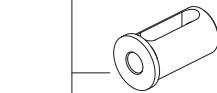

Boring bar sleeve

165-63356 (Ø16)

165-63358 (Ø20)

165-63359 (Ø25)

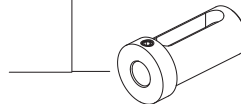

Boring bar sleeve

165-63347 (Ø16)

165-63349 (Ø20)

165-63350 (Ø25)

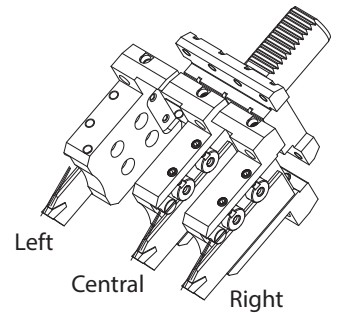

Left

Central

Right

PORTAUTENSILE ASSIALE - AXIAL TOOLHOLDERS

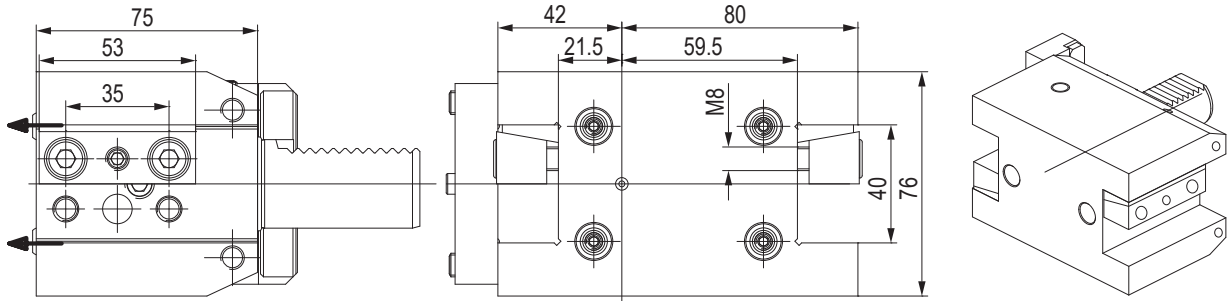

CODE N.	CLAMPING PLATE	COOLANT NOZZLE	STOP PLATE	SCREW FOR STOP PLATE	STOP SCREW	O RING FOR VDI30
112-130050	832-007190	833-001110	832-018380	811-101038	811-102020	823-101017

PORTAUTENSILE ASSIALE - AXIAL TOOLHOLDERS

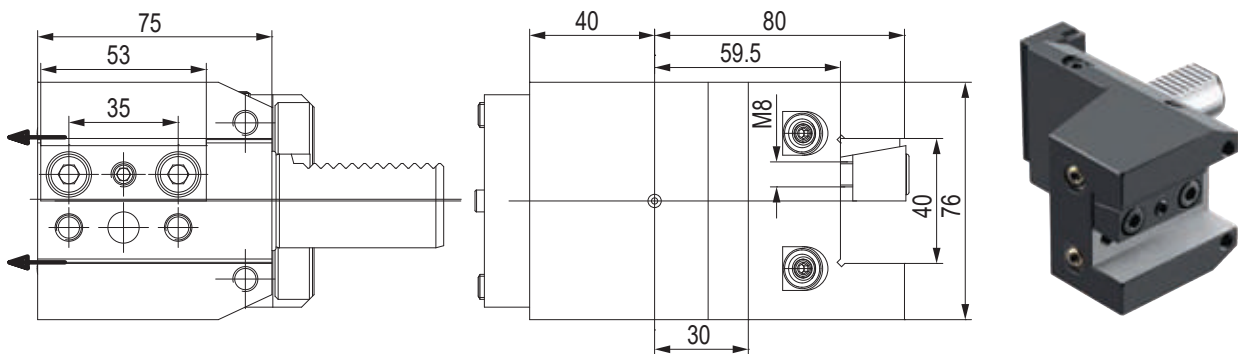

CODE N.	CLAMPING PLATE	COOLANT NOZZLE	STOP PLATE	SCREW FOR STOP PLATE	STOP SCREW	O RING FOR VDI30
112-330080	832-007190	833-001110	832-018380	811-101038	811-102020	823-101017

PORTALAMA - CUT-OFF HOLDERS

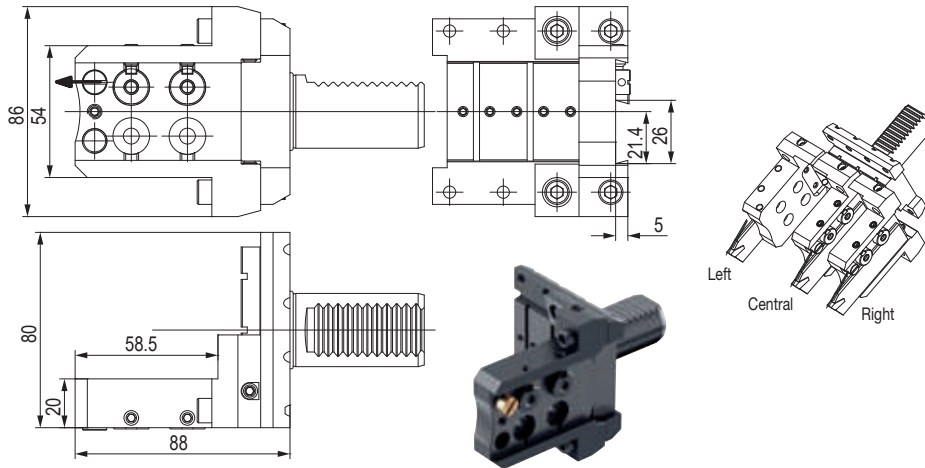

CODE N.	COOLANT NOZZLE	O RING FOR COOLANT NOZZLE	O RING FOR BODY	O RING FOR VDI30
117-53001	833-001490	823-101058	823-101061	823-101017

CODE N.	SHIM PLATE	SCREW FOR PLATE	CLAMPING PIN	SPRING	CLAMPING SCREW	SCREW
117-53001	832-014448	811-108037	832-014447	824-300012	811-101027	811-104013

PORTAUTENSILE COMBINATO PER BARENI E PUNTE A INSERTI COMBI TOOLHOLDER FOR BORING BAR AND INSERTDRILL

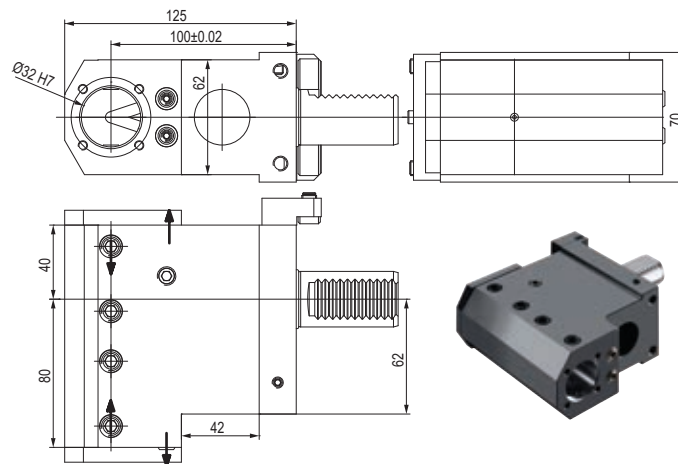

CODE N.	CLAMPING SCREW	COOLANT NOZZLE	STOP PLATE	SCREW FOR STOP PLATE	STOP SCREW
115-230450	811-102043	833-001110	832-018380	811-101038	811-102020

CODE N.	COVER	SCREW FOR COVER	O RING FOR VDI30
115-230450	832-003212	811-101016	823-101017

PORTAUTENSILE COMBINATO PER BARENI E PUNTE A INSERTI COMBI TOOLHOLDER FOR BORING BAR AND INSERTDRILL

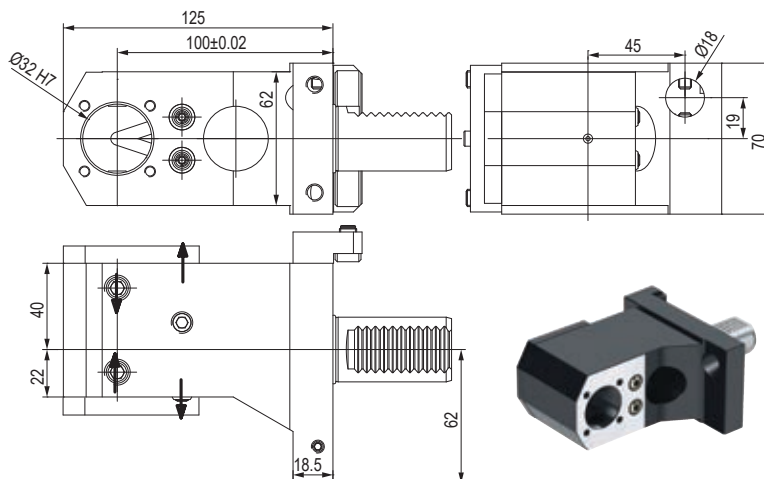

CODE N.	CLAMPING SCREW	COOLANT NOZZLE	STOP PLATE	SCREW FOR STOP PLATE	STOP SCREW
115-230460	811-102043	833-001110	832-018380	811-101038	811-102020

CODE N.	COVER	SCREW FOR COVER	O RING FOR VDI30
115-230460	832-003212	811-101016	823-101017

BUSSOLA PER PORTABARENI BORING BAR SLEEVE FOR TOOLHOLDER

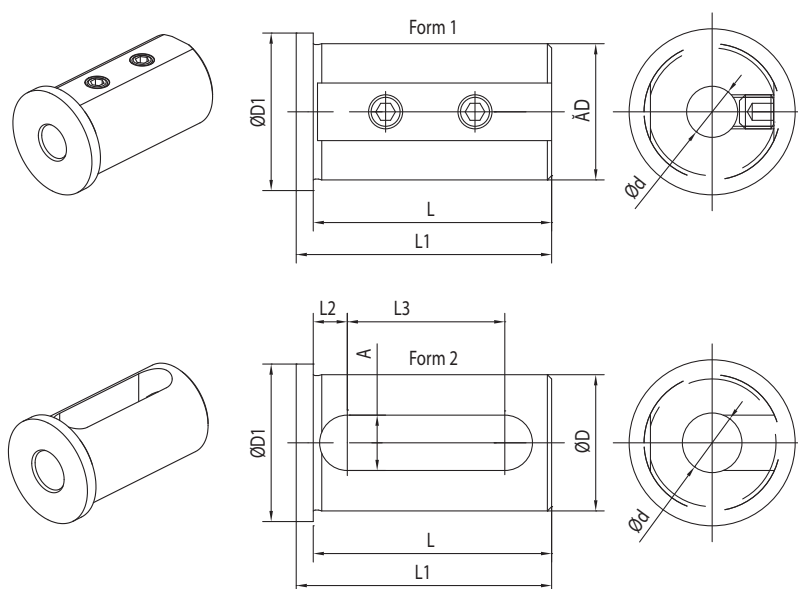

CODE N.	D	d	FORM	L	L1	L2	L3	A	D1
165-63352	32	8	1	56	60	-	-	-	37
165-63353	32	10	1	56	60	-	-	-	37
165-63354	32	12	1	56	60	-	-	-	37
165-63356	32	16	2	56	60	8	37	13	37
165-63358	32	20	2	56	60	8	37	13	37
165-63359	32	25	2	56	60	8	37	13	37

BUSSOLA PER PORTABARENI BORING BAR SLEEVE FOR TOOLHOLDER

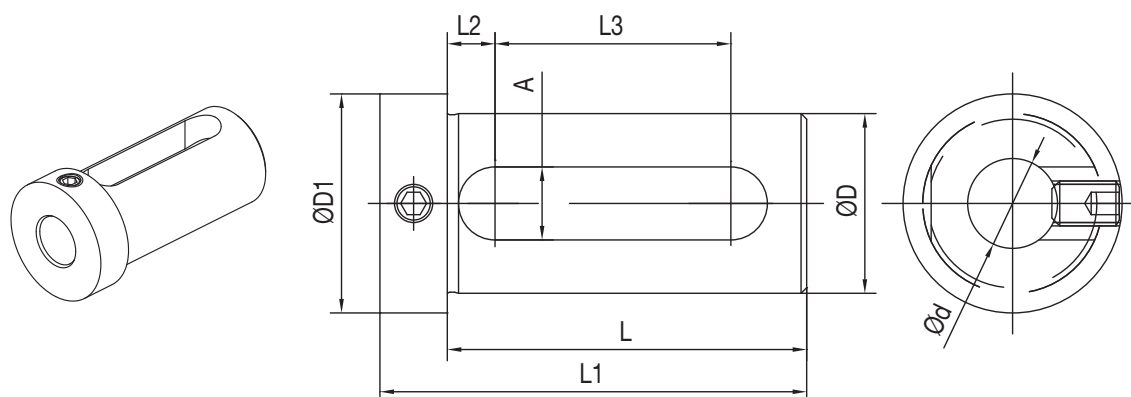

CODE N.	D	d	L	L1	L2	L3	A	D1
165-63347	32	16	64	76	8,5	42	13	39
165-63349	32	20	64	76	8,5	42	13	39
165-63350	32	25	64	76	8,5	42	13	39



OKUMA
(VDI40)

LT15M
LT300M
MT250
LB300
LB300M
LV300

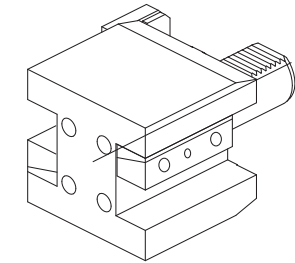

112-14009

Face and O.D.
cutting holder

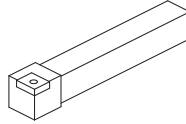

Qualified tool
25x25 mm

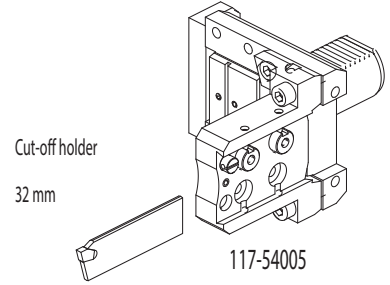

Cut-off holder
32 mm

117-54005

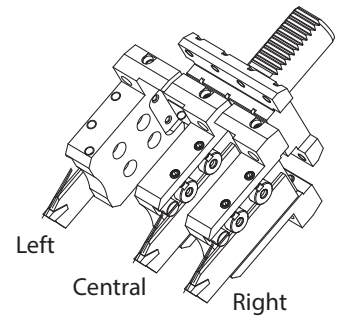

Left

Central

Right

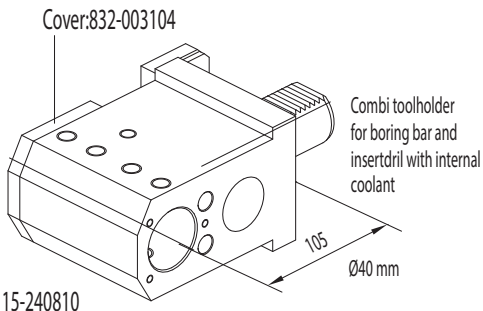

115-240810

Combi toolholder
for boring bar and
insertdrill with internal
coolant

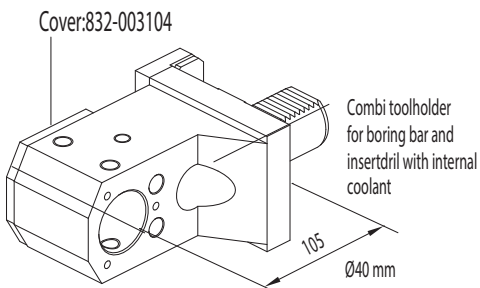

115-240700

Combi toolholder
for boring bar and
insertdrill with internal
coolant

ACCESSORIES

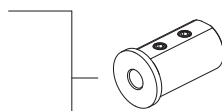

- Boring bar sleeve
165-64247 (Ø8)
165-64248 (Ø10)
165-64249 (Ø12)

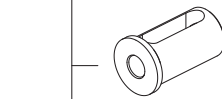

- Boring bar sleeve
165-64251 (Ø16)
165-64253 (Ø20)
165-64254 (Ø25)
165-64255 (Ø32)

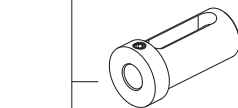

- Boring bar sleeve
165-64241 (Ø16)
165-64243 (Ø20)
165-64244 (Ø25)
165-64245 (Ø32)

PORTAUTENSILE ASSIALE - AXIAL TOOLHOLDERS

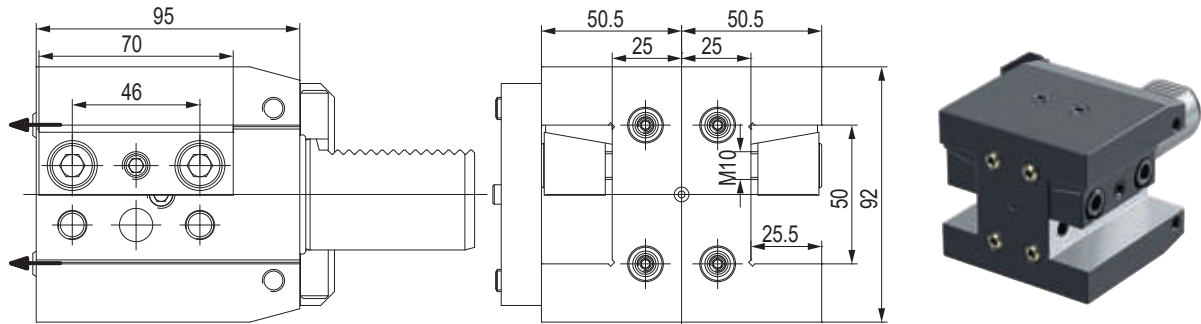

CODE N.	CLAMPING PLATE	COOLANT NOZZLE	STOP PLATE	SCREW FOR STOP PLATE	O RING FOR VDI40
112-14009	832-007010	833-001110	832-020730	811-101039	823-101036

PORTALAMA - CUT-OFF HOLDERS

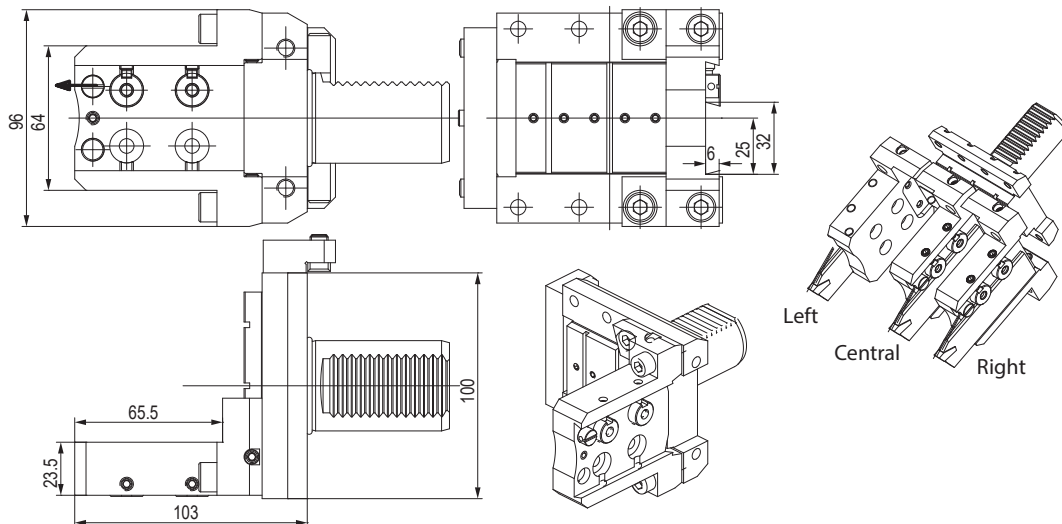

CODE N.	COOLANT NOZZLE	O RING FOR COOLANT NOZZLE	O RING FOR BODY	O RING FOR VDI40	STOP PLATE	SCREW FOR STOP PLATE
117-54005	833-001490	823-101058	823-101061	823-101036	832-020730	811-101039

CODE N.	SHIM PLATE	SCREW FOR PLATE	CLAMPING PIN	SPRING	CLAMPING SCREW	SCREW
117-54005	832-014449	811-108037	832-014450	824-300012	811-101028	811-104013

**PORTAUTENSILE COMBINATO PER BARENI E PUNTE A INSERTI
COMBI TOOLHOLDER FOR BORING BAR AND INSERTDRILL**

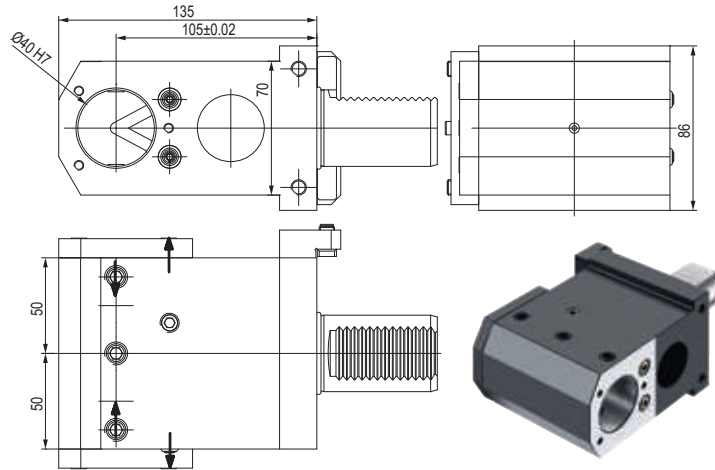

CODE N.	CLAMPING SCREW	COOLANT NOZZLE	STOP PLATE	SCREW FOR STOP PLATE
115-240810	811-102043	833-001110	832-020730	811-101039

CODE N.	COVER	SCREW FOR COVER	O RING FOR VDI40
115-240810	832-003104	811-101017	823-101036

**PORTAUTENSILE COMBINATO PER BARENI E PUNTE A INSERTI
COMBI TOOLHOLDER FOR BORING BAR AND INSERTDRILL**

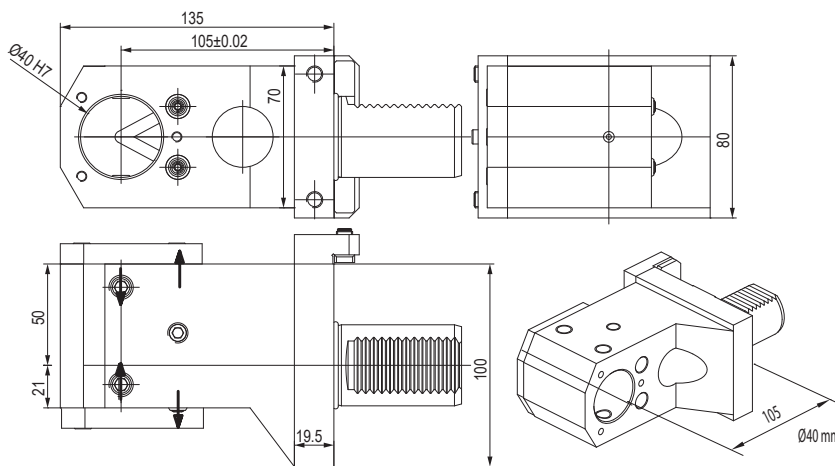

CODE N.	CLAMPING SCREW	COOLANT NOZZLE	STOP PLATE	SCREW FOR STOP PLATE
115-240700	811-102043	833-001110	832-020730	811-101039

CODE N.	COVER	SCREW FOR COVER	O RING FOR VDI40
115-240700	832-003104	811-101017	823-101036

BUSSOLA PER PORTABARENI BORING BAR SLEEVE FOR TOOLHOLDER

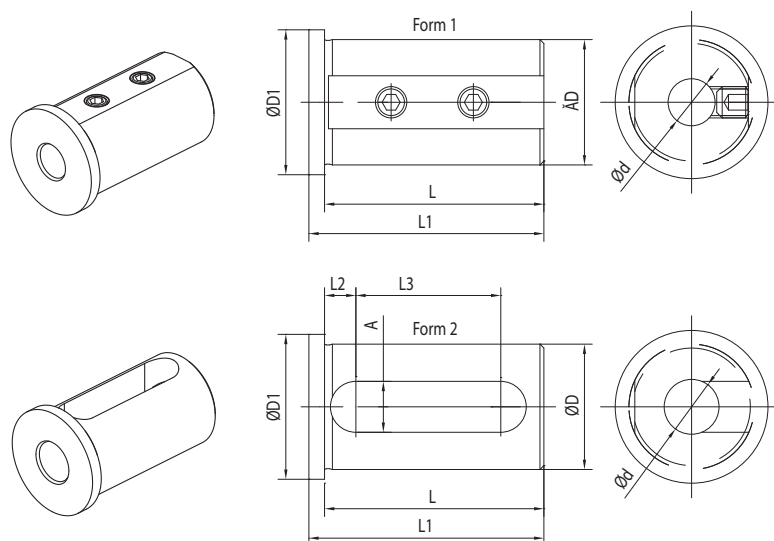

CODE N.	D	d	FORM	L	L1	L2	L3	A	D1
165-64247	40	8	1	71	75	-	-	-	45
165-64248	40	10	1	71	75	-	-	-	45
165-64249	40	12	1	71	75	-	-	-	45
165-64251	40	16	2	71	75	8	52	13	45
165-64253	40	20	2	71	75	8	52	13	45
165-64254	40	25	2	71	75	8	52	13	45
165-64255	40	32	2	71	75	8	52	13	45

BUSSOLA PER PORTABARENI BORING BAR SLEEVE FOR TOOLHOLDER

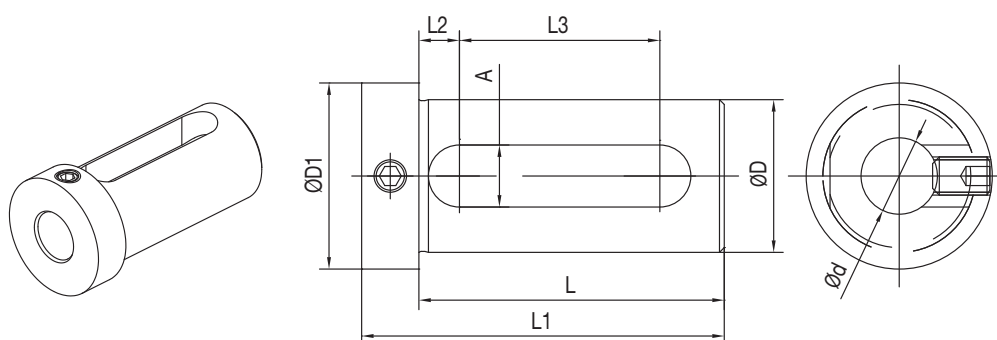

CODE N.	D	d	L	L1	L2	L3	A	D1
165-64241	40	16	74	88	9	51	14	48
165-64243	40	20	74	88	9	51	14	48
165-64244	40	25	74	88	9	51	14	48
165-64245	40	32	74	88	9	51	14	48

OKUMA

LB15
LB25
LB15II
LB300

HAAS

SL20 - SL30
ST-20 - ST-25
ST-30 - ST-35
DS-30

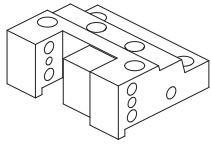

128-420110

Face and O.D.
cutting holder

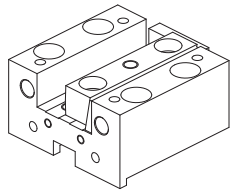

128-32001

Face and I.D.
cutting holder

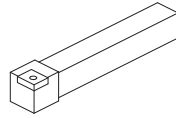

Qualified tool
25x25 mm

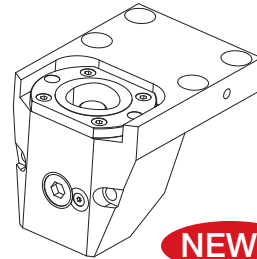

128-12072 (C40)
128-12059 (C50)

Face and O.D.
cutting holder
Polygonal

NEWS

CONNECTION

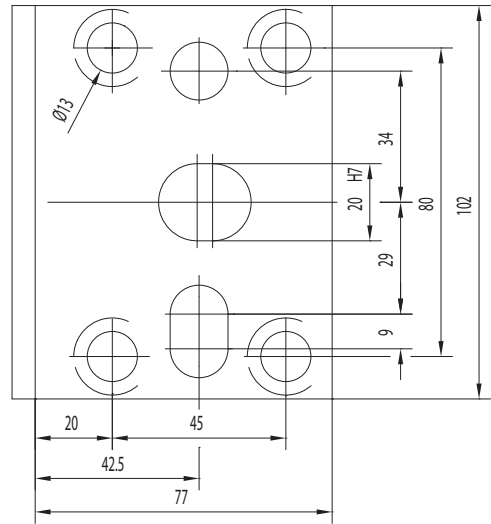

ACCESSORIES

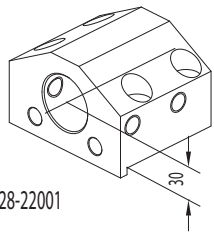

128-22001

Toolholder
for boring bar
Ø40 mm

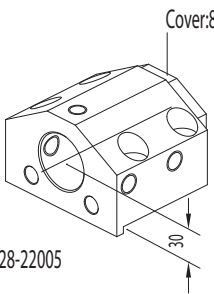

128-22005

Cover:832-003056

Combi toolholder
for boring bar and
insert drill with internal
coolant
Ø40 mm

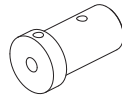

Boring bar sleeve and
throw-away drill socket

165-64013 (Ø10)
165-64014 (Ø12)
165-64015 (Ø16)
165-64016 (Ø20)

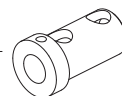

Boring bar sleeve and
throw-away drill socket

165-64017 (Ø25)
165-64018 (Ø32)

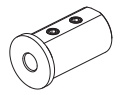

Boring bar sleeve
165-64247 (Ø8)
165-64248 (Ø10)
165-64249 (Ø12)

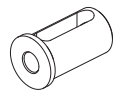

Boring bar sleeve
165-64251 (Ø16)
165-64253 (Ø20)
165-64254 (Ø25)
165-64255 (Ø32)

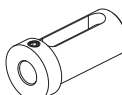

Boring bar sleeve
165-64241 (Ø16)
165-64243 (Ø20)
165-64244 (Ø25)
165-64245 (Ø32)

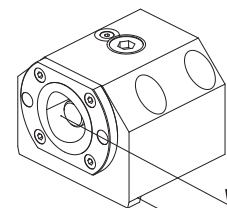

128-12071 (C40)
128-12057 (C50)

Boring bar holder
Polygonal



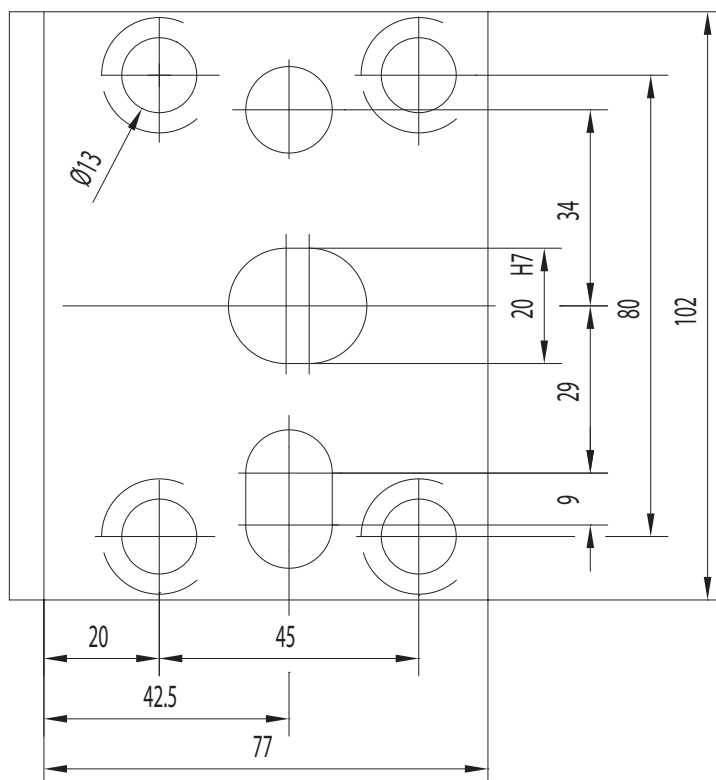

NEWS

CONNECTION

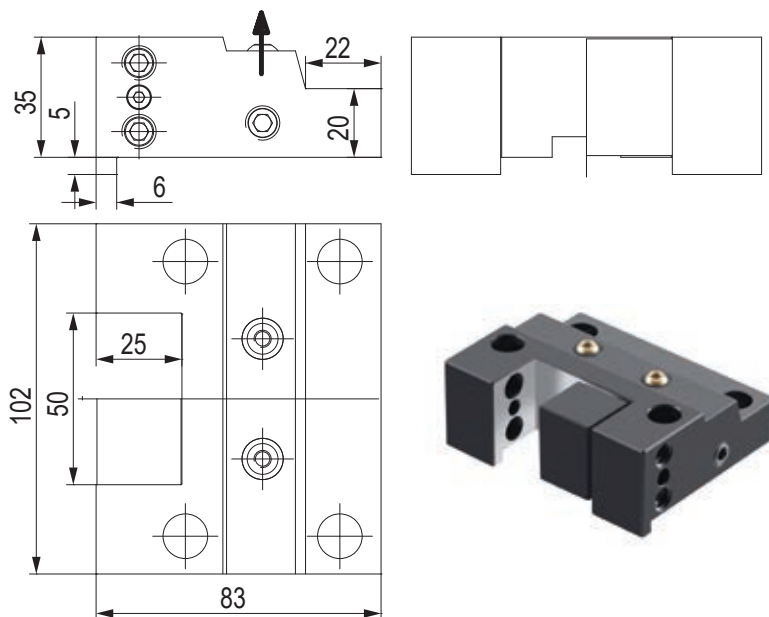

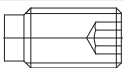
PORTAUTENSILE RADIALE - RADIAL TOOLHOLDERS

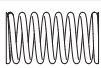

CODE N.	CLAMPING SCREW	CLAMPING PLATE	SCREW FOR CLAMPING PLATE	SPRING FOR CLAMPING PLATE	COOLANT NOZZLE
128-420110					
	811-104030	832-002069	811-302004	824-101010	833-001080

PORTAUTENSILE ASSIALE - AXIAL TOOLHOLDERS

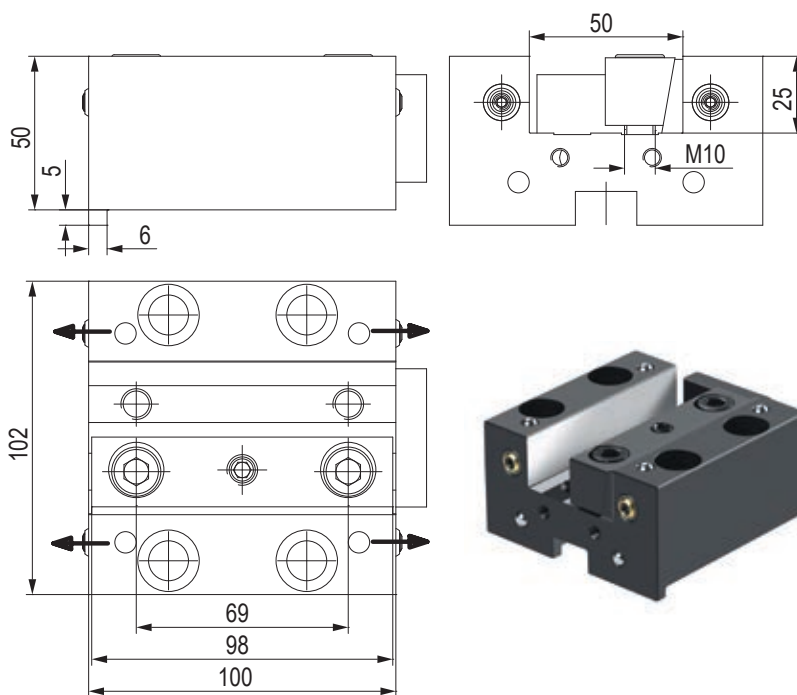

CODE N.	CLAMPING PLATE	COOLANT NOZZLE	STOP PLATE	SCREW FOR PLATE
128-32001	832-007220	833-001110	832-003045	811-101026

PORTAUTENSILE PER BARENI - TOOLHOLDER FOR BORING BAR

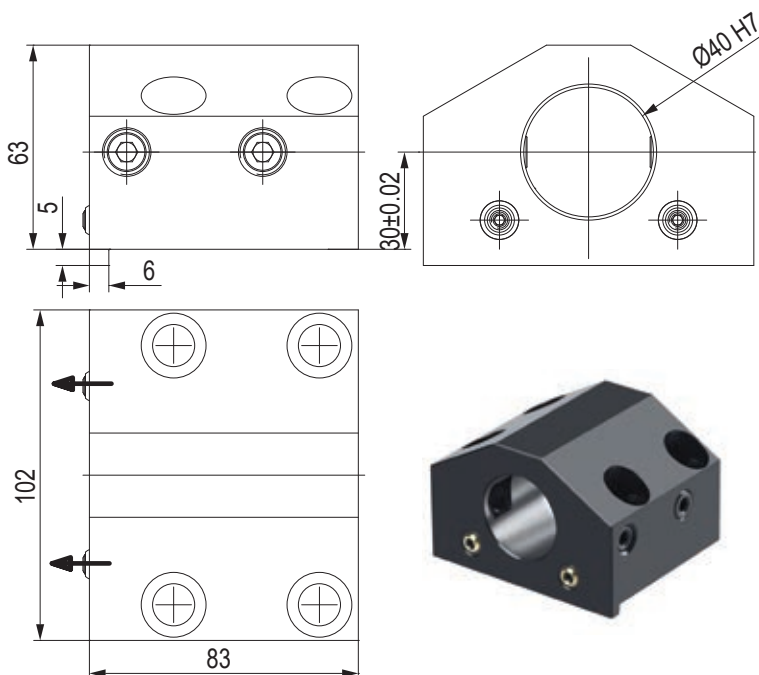

CODE N.	CLAMPING SCREW	COOLANT NOZZLE
128-22001	811-104069	833-001110

PORTAUTENSILE COMBINATO PER BARENI E PUNTE A INSERTI COMBI TOOLHOLDER FOR BORING BAR AND INSERTDRILL

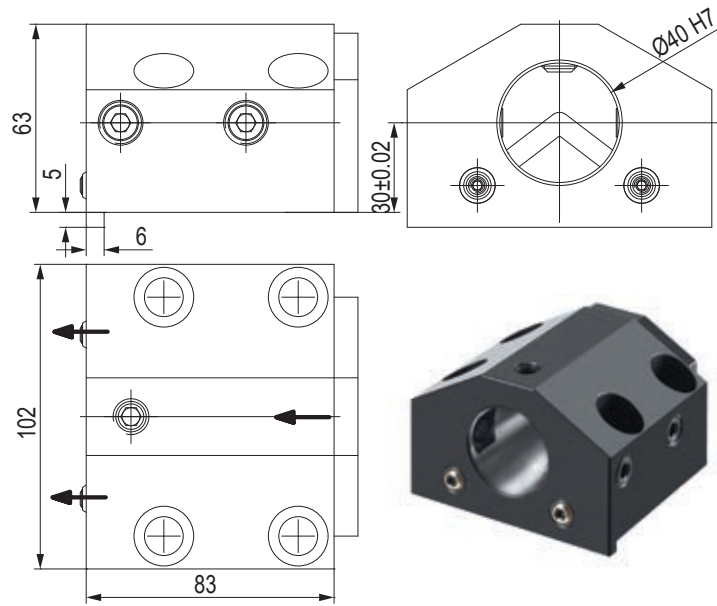

CODE N.	CLAMPING SCREW1	CLAMPING SCREW2	COOLANT NOZZLE	COVER	SCREW FOR COVER
128-22005	811-104069	811-102043	833-001110	832-003056	811-101016

PORTAUTENSILE CON USCITA POLIGONALE POLIGONAL TOOLHOLDERS

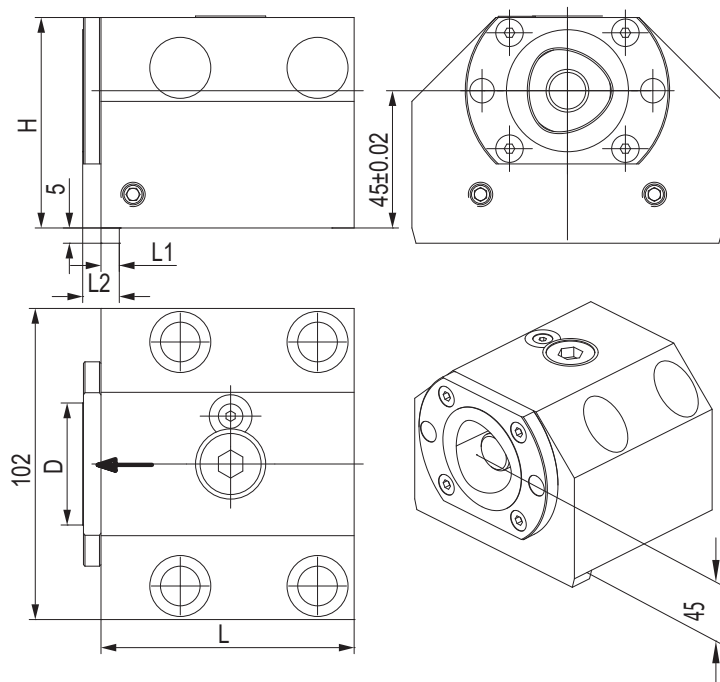

CODE N.	CAPTO	D	H	L	L1	L2	CLAMPING UNIT
128-12071	C40	40	69	83	6	12	CXC40-10
128-12057	C50	50	77	88	11	19	CXC50-10

PORTAUTENSILE CON USCITA POLIGONALE POLIGONAL TOOLHOLDERS

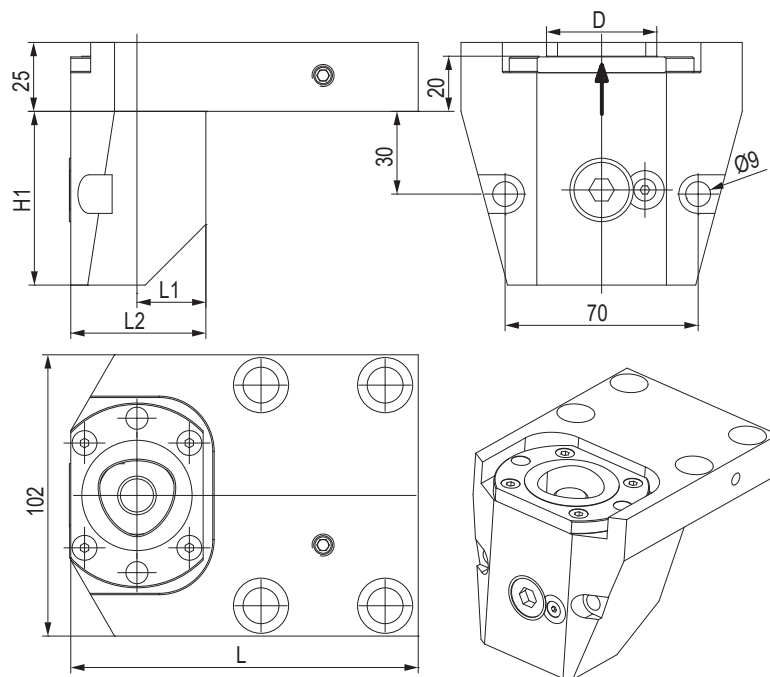

CODE N.	CAPTO	D	H	L	L1	L2	CLAMPING UNIT
128-12072	C40	40	63	126	25	49	CXC40-10
128-12059	C50	50	75	142	33	65	CXC50-10

BUSSOLA PER PORTABARENI BORING BAR SLEEVE FOR TOOLHOLDER

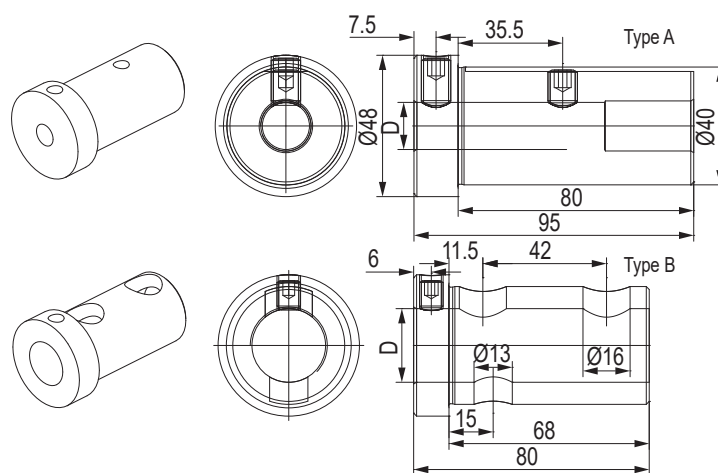

CODE N.	Ø	D	TYPE	SCREW1 (Long)	SCREW2 (Short)
165-64013	40	10	A	811-10230	811-10229
165-64014	40	12	A	811-10237	811-10236
165-64015	40	16	A	811-10237	811-10236
165-64016	40	20	A	811-10236	811-10235
165-64017	40	25	B	811-10227	-
165-64018	40	32	B	811-10226	-

BUSSOLA PER PORTABARENI DRILL SOCKET FOR TOOLHOLDER

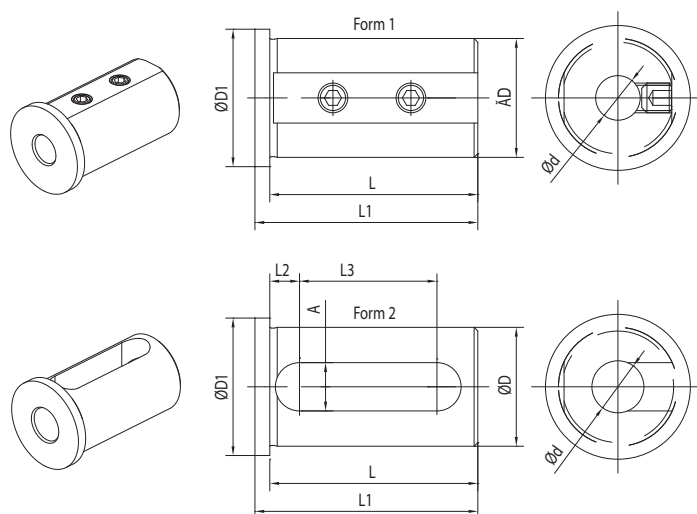

CODE N.	D	d	FORM	L	L1	L2	L3	A	D1
165-64247	40	8	1	71	75	-	-	-	45
165-64248	40	10	1	71	75	-	-	-	45
165-64249	40	12	1	71	75	-	-	-	45
165-64251	40	16	2	71	75	8	52	13	45
165-64253	40	20	2	71	75	8	52	13	45
165-64254	40	25	2	71	75	8	52	13	45
165-64255	40	32	2	71	75	8	52	13	45

BUSSOLA PER PORTABARENI DRILL SOCKET FOR TOOLHOLDER

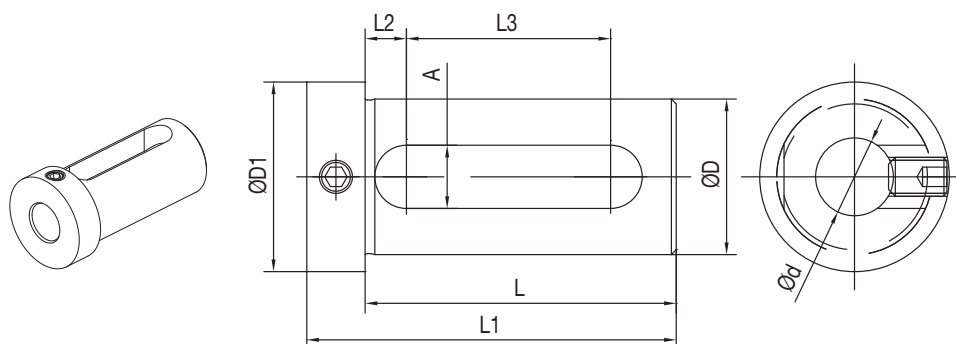

CODE N.	D	d	L	L1	L2	L3	A	D1
165-64241	40	16	74	88	9	51	14	48
165-64243	40	20	74	88	9	51	14	48
165-64244	40	25	74	88	9	51	14	48
165-64245	40	32	74	88	9	51	14	48

OKUMA (BMT60)

LB2000 EX (M)
 LB2500 EX (M)
 LB3000 EX (M, MY)
 LT2000 EX
 LT3000 EX
 LB3000 EX (MW, MYW)

LU2000 EX
 LU2500 EX
 LU3000 EX (M, MW, MY)
 GENOS L300 (MY, MW, MYW)

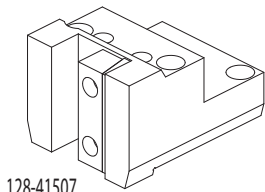

128-41507

Face and O.D.
cutting holder

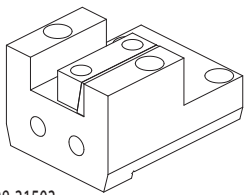

128-31503

Face and I.D.
cutting holder

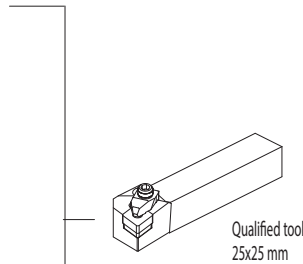

Qualified tool
25x25 mm



124-06005
124-06006 I.Coolant



124-06007
124-06008 I.Coolant

FAST-IN

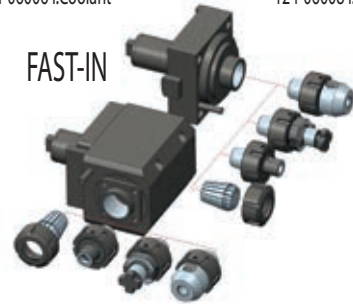

ACCESSORIES

CONNECTION

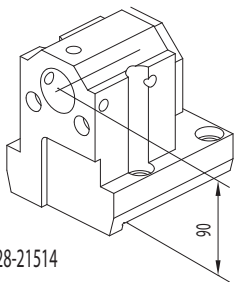

128-21514

Combi toolholder
for boring bar and
insertdrill
Ø32 mm

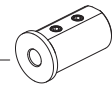

Boring bar sleeve
165-63352 (Ø8)
165-63353 (Ø10)
165-63354 (Ø12)

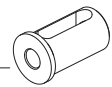

Boring bar sleeve
165-63356 (Ø16)
165-63358 (Ø20)
165-63359 (Ø25)

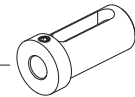

Boring bar sleeve
165-63347 (Ø16)
165-63349 (Ø20)
165-63350 (Ø25)

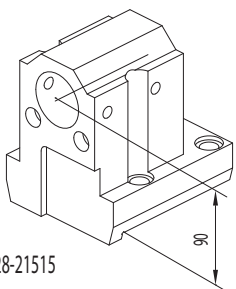

128-21515

Toolholder
for boring bar
Ø40 mm

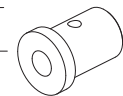

Throw-away drill socket
165-64205 (Ø25)
165-64206 (Ø32)

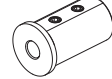

Boring bar sleeve
165-64247 (Ø8)
165-64248 (Ø10)
165-64249 (Ø12)

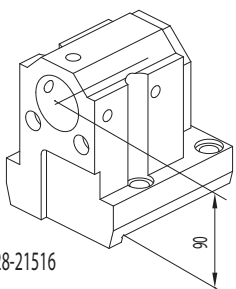

128-21516

Combi toolholder
for boring bar and
insertdrill
Ø40 mm

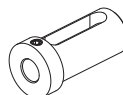

Boring bar sleeve
165-64241 (Ø16)
165-64243 (Ø20)
165-64244 (Ø25)
165-64245 (Ø32)

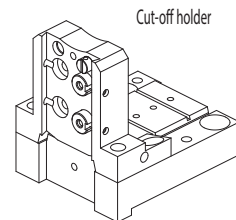
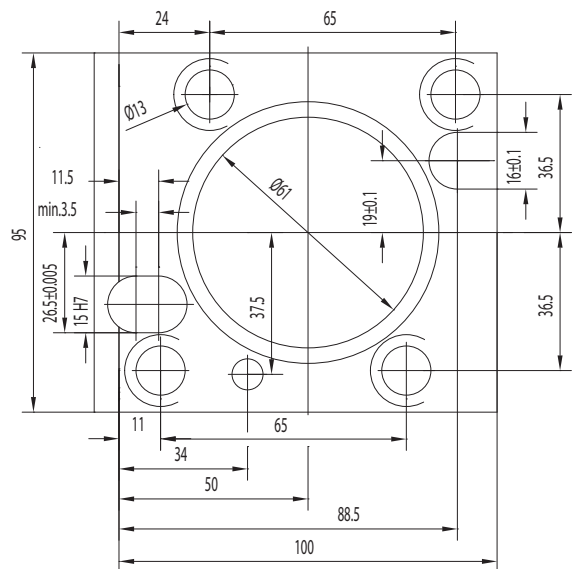

128-11535 (h=32 mm)
128-11534 (h=26 mm)



Cut-off tool
32 mm
26 mm

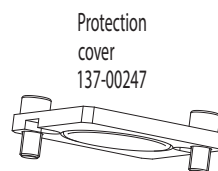

Protection
cover
137-00247

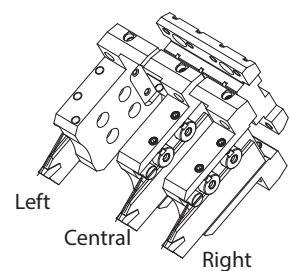

Left
Central
Right

CONNECTION

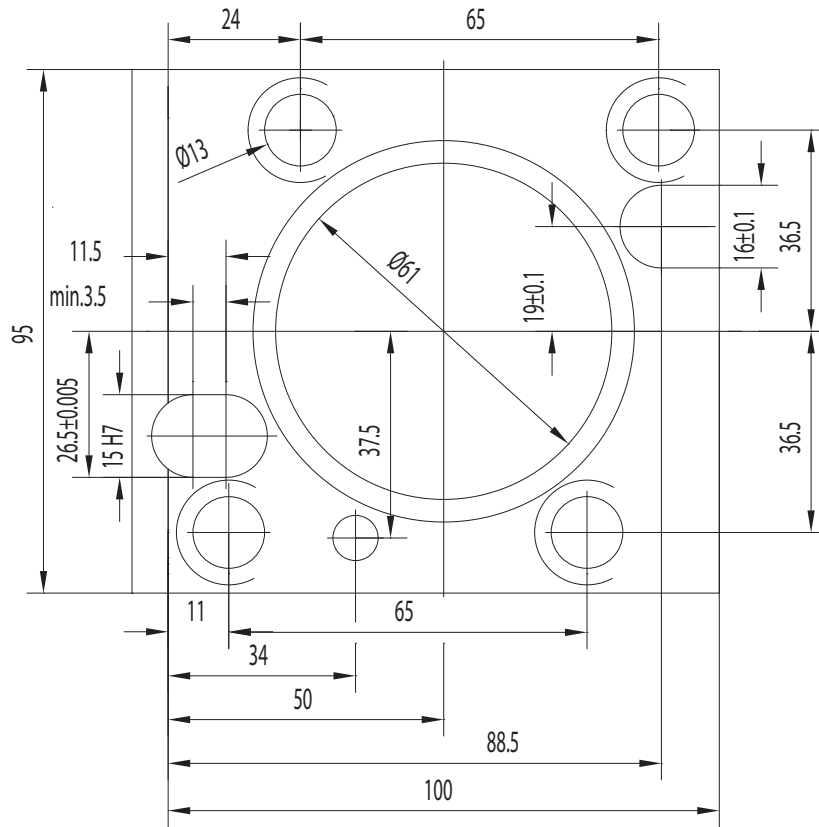



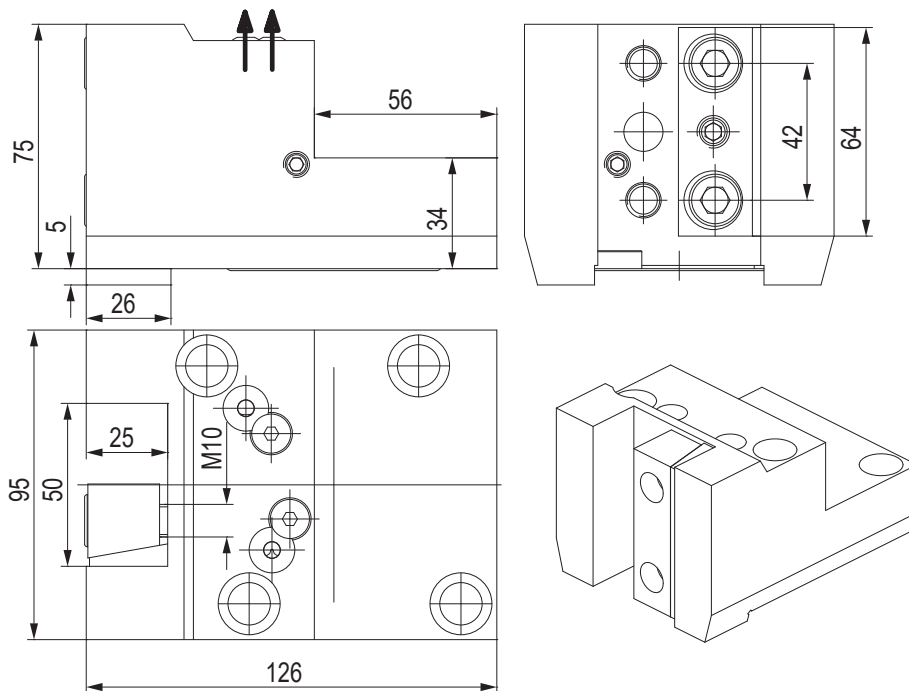

PORTAUTENSILE RADIALE - RADIAL TOOLHOLDERS

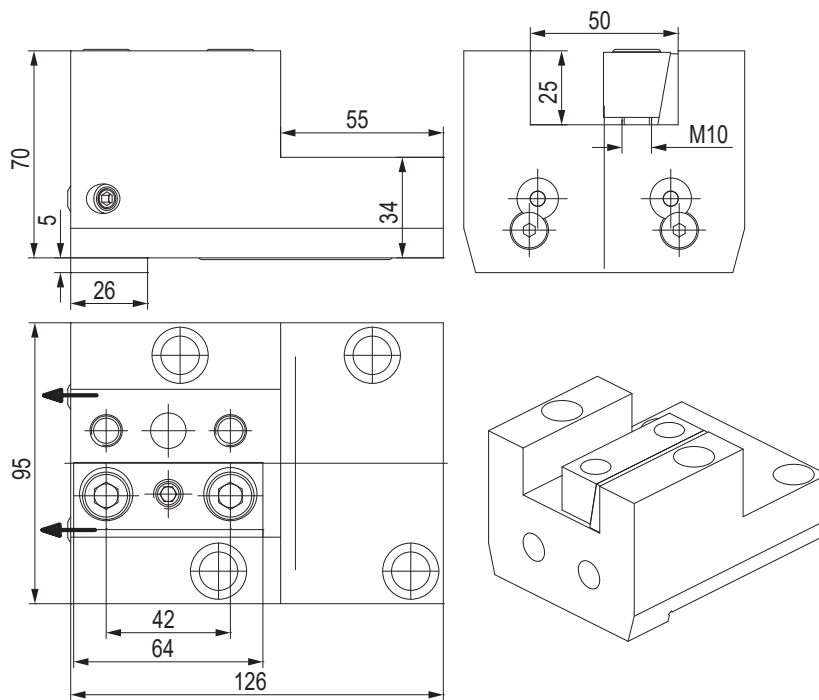

CODE N.	CLAMPING PLATE	COOLANT BALL	SCREW FOR BALL	O RING
128-41507	832-007360	833-001470	811-108018	823-101084

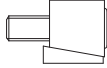

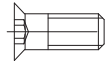
PORTAUTENSILE ASSIALE - AXIAL TOOLHOLDERS

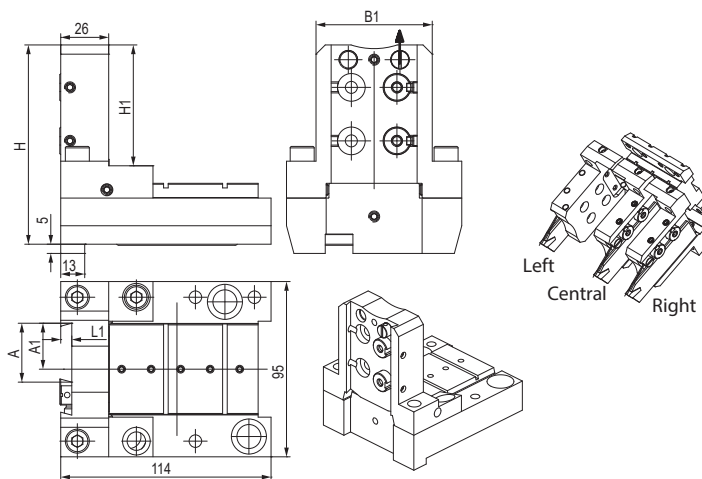

CODE N.	CLAMPING PLATE	COOLANT BALL	SCREW FOR BALL	O RING
128-31503				
128-31503	832-007360	833-001470	811-108018	823-101084

PORTALAMA - CUT-OFF HOLDERS

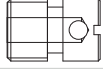

CODE N.	A	A1	L1	B1	H	H1	COOLANT NOZZLE	O RING FOR COOLANT NOZZLE	O RING FOR BODY	CODE N.
128-11534	26	21.4	5	54	101	58.5				823-101084
128-11535	32	25	6	63	108	65.5	833-001490	823-101058	823-101061	823-101084

CODE N.	SHIM PLATE	SCREW FOR PLATE	CLAMPING PIN	SPRING	CLAMPING SCREW	SCREW
128-11534						
128-11534	832-014449	811-108037	832-014447	824-300012	811-101028	811-104013
128-11535	832-014449	811-108037	832-014450	824-300012	811-101028	811-104013

PORTAUTENSILE COMBINATO PER BARENI E PUNTE A INSERTI COMBI TOOLHOLDER FOR BORING BAR AND INSERTDRILL

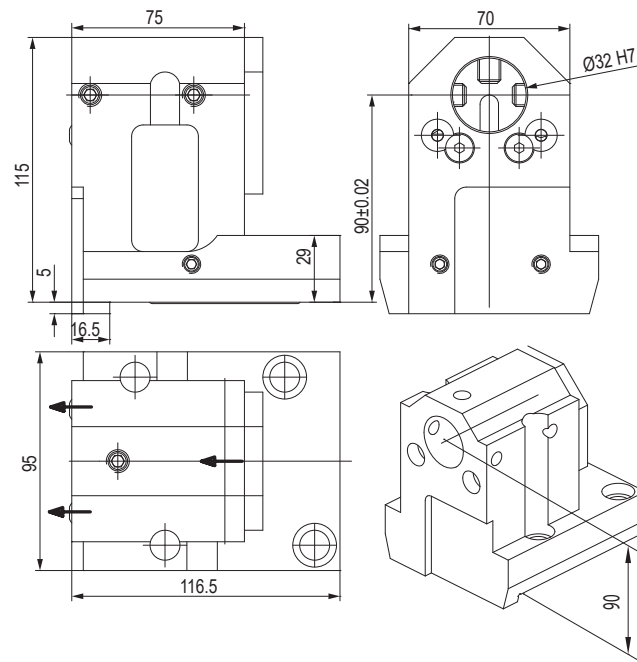

CODE N.	CLAMPING SCREW1 (M10X25)	CLAMPING SCREW2 (M10X20)	COOLANT BALL	SCREW FOR BALL	O RING	COVER	SCREW FOR COVER
128-21514	811-102039	811-102038	833-001470	811-108018	823-101084	832-003297	811-101016

PORTAUTENSILE PER BARENI TOOLHOLDER FOR BORING BAR

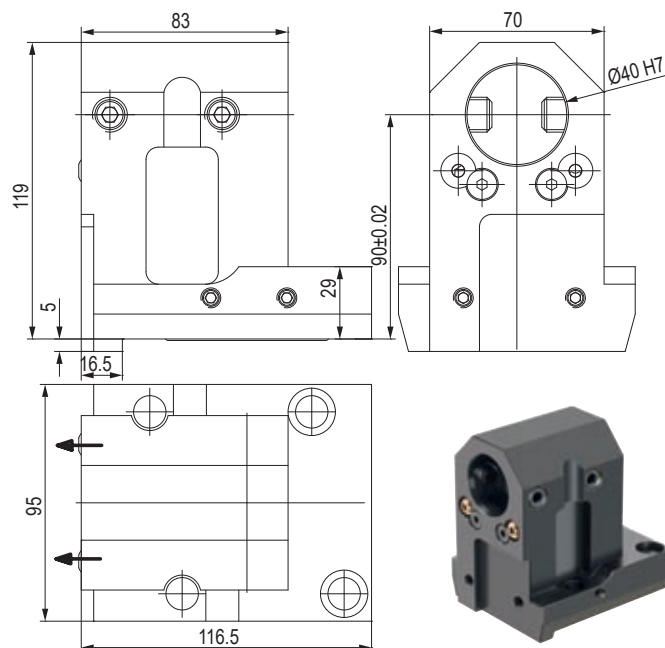

CODE N.	CLAMPING SCREW	COOLANT BALL	SCREW FOR BALL	O RING
128-21515	811-102088	833-001470	811-108018	823-101084

PORTAUTENSILE COMBINATO PER BARENI E PUNTE A INSERTI COMBI TOOLHOLDER FOR BORING BAR AND INSERTDRILL

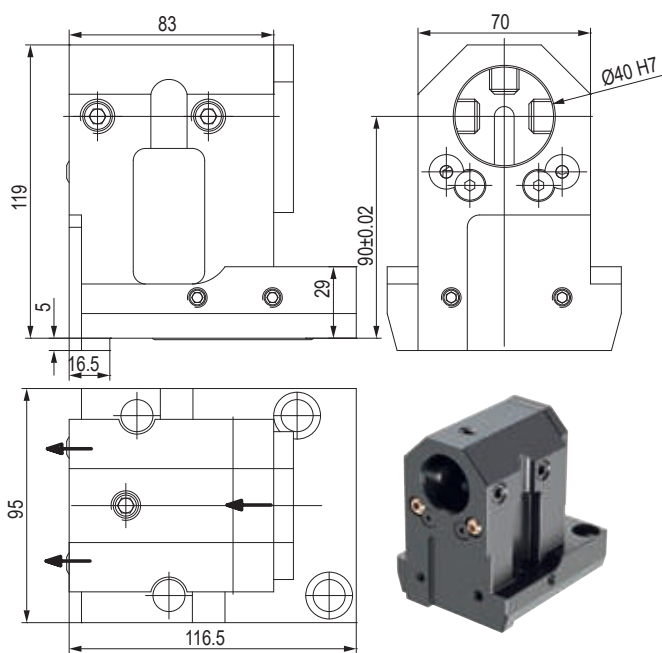

CODE N.	CLAMPING SCREW1 (M14X25)	CLAMPING SCREW2 (M12X20)	COOLANT BALL	SCREW FOR BALL	O RING	COVER	SCREW FOR COVER
128-21516	811-102088	811-102044	833-001470	811-108018	823-101084	832-003297	811-101016

PORTAUTENSILE MOTORIZZATO ASSIALE STRAIGHT DRILLING AND MILLING HEAD

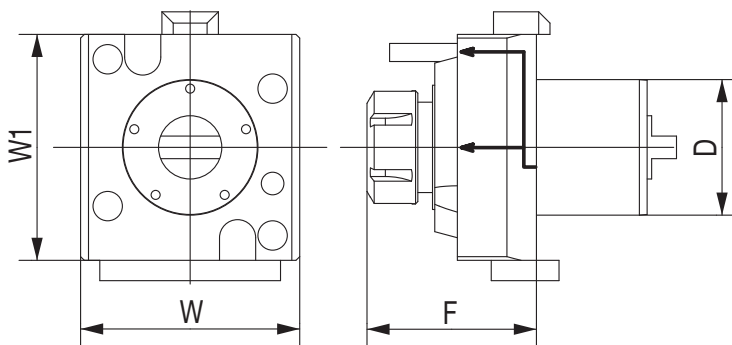

CODE N.	D	ER	INTERNAL COOLING	F	W	W1	TORQUE (Nm)	NMAX (Rpm)	RATIO	P (Bar)
124-06005	60	ER32	no	87	97	100	70	6000	1:1	-
124-06006	60	ER32	yes	87	97	100	70	6000	1:1	20

PORTAUTENSILE MOTORIZZATO RADIALE ANGULAR DRILLING AND MILLING HEAD

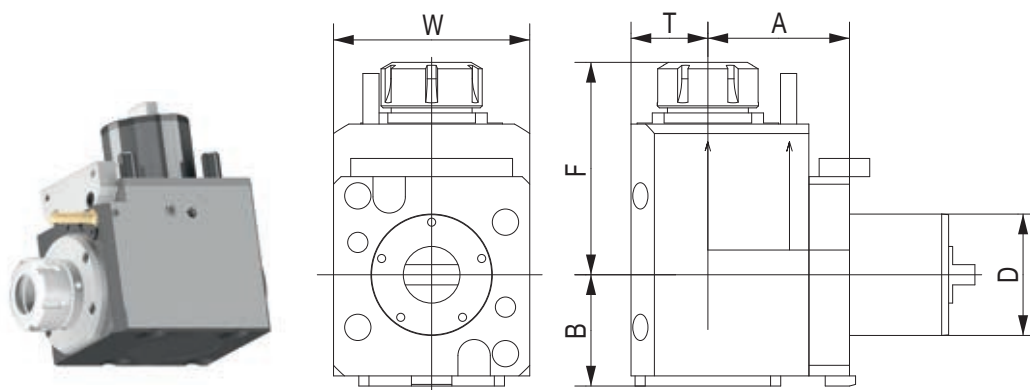

CODE N.	D	ER	INTERNAL COOLING	DIRECTION	A	B	F	T	W	TORQUE (Nm)	NMAX (Rpm)	RATIO	P (Bar)
124-06007	60	ER32	no	right/left	70	59	111	38	94	70	6000	1:1	-
124-06008	60	ER32	yes	right/left	70	59	111	38	94	70	6000	1:1	20

BARRA DI CONTROLLO - CONTROL PIN

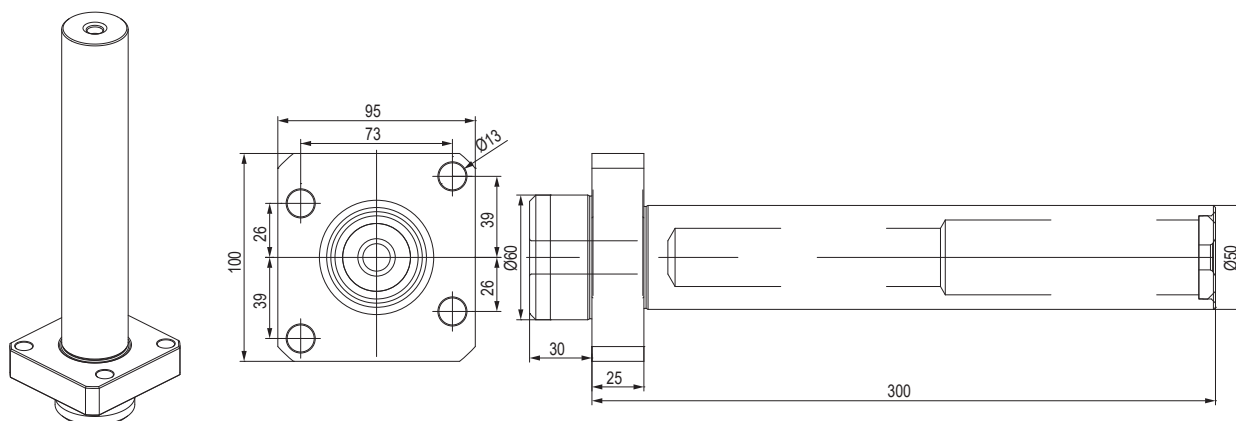

CODE N.

137-00195

TAPPO DI PROTEZIONE - PROTECTION COVER

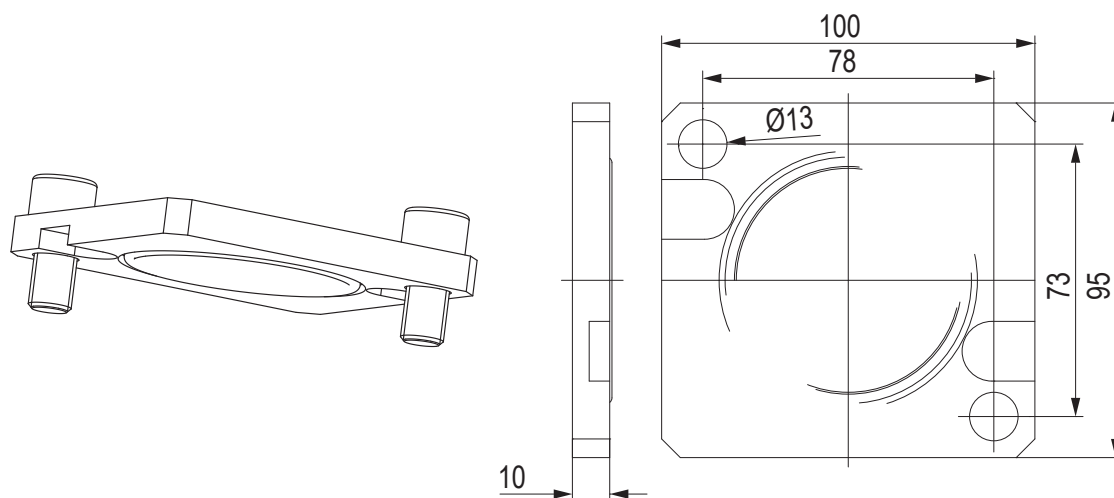

CODE N.

O RING



137-00247

823-101084

12

KINTEK®



BUSSOLA PER PORTABARENI THROW-AWAY DRILL SOCKET FOR TOOLHOLDER

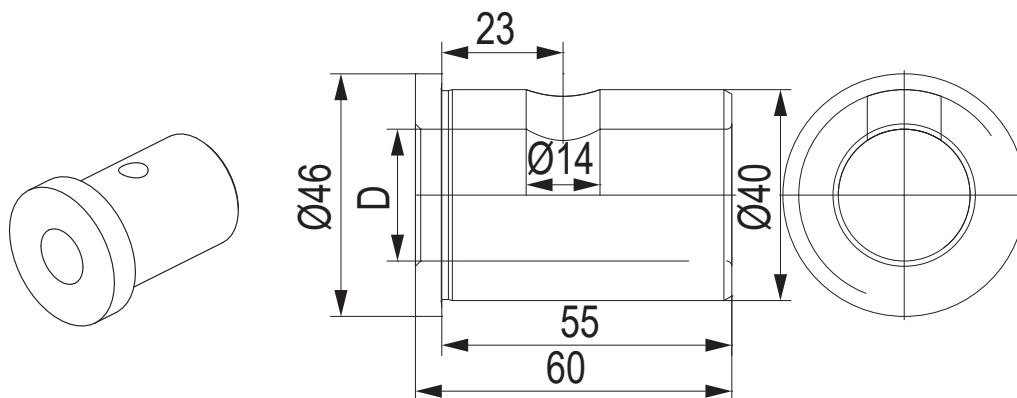

CODE N.	Ø	D
165-64205	40	25
165-64206	40	32

BUSSOLA PER PORTABARENI DRILL SOCKET FOR TOOLHOLDER

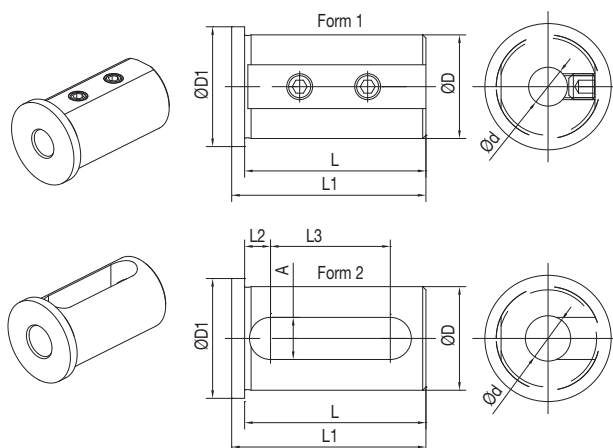

CODE N.	D	d	FORM	L	L1	L2	L3	A	D1
165-63352	32	8	1	56	60	-	-	-	37
165-63353	32	10	1	56	60	-	-	-	37
165-63354	32	12	1	56	60	-	-	-	37
165-63356	32	16	2	56	60	8	37	13	37
165-63358	32	20	2	56	60	8	37	13	37
165-63359	32	25	2	56	60	8	37	13	37
165-64247	40	8	1	71	75	-	-	-	45
165-64248	40	10	1	71	75	-	-	-	45
165-64249	40	12	1	71	75	-	-	-	45
165-64251	40	16	2	71	75	8	52	13	45
165-64253	40	20	2	71	75	8	52	13	45
165-64254	40	25	2	71	75	8	52	13	45
165-64255	40	32	2	71	75	8	52	13	45

BUSSOLA PER PORTABARENI DRILL SOCKET FOR TOOLHOLDER

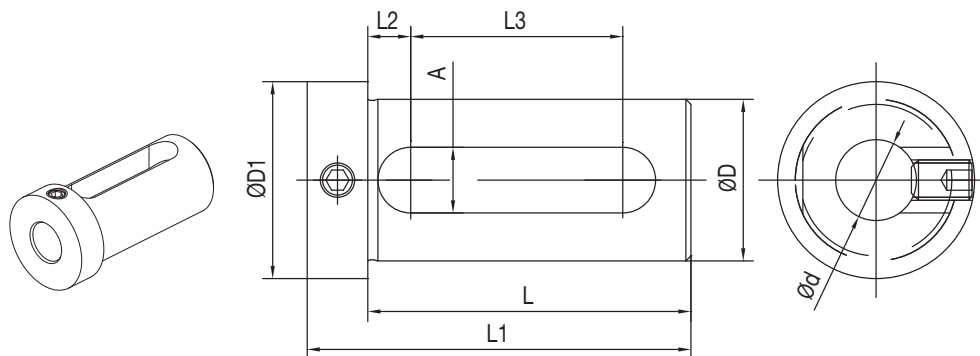

CODE N.	D	d	L	L1	L2	L3	A	D1
165-63347	32	16	65	77	8	42	13	39
165-63349	32	20	65	77	8	42	13	39
165-63350	32	25	65	77	8	42	13	39
165-64241	40	16	75	89	9	51	14	48
165-64243	40	20	75	89	9	51	14	48
165-64244	40	25	75	89	9	51	14	48
165-64245	40	32	75	89	9	51	14	48



OKUMA LB3000 EX (MW, MYW)
(BMT60)

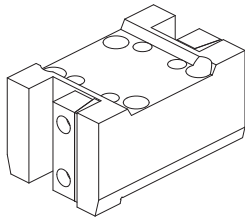

128-41509

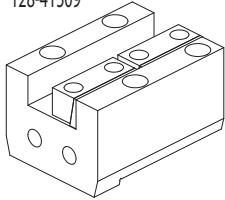

128-31505

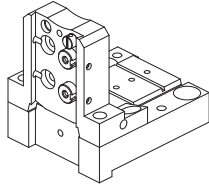

128-11535 (h=32 mm)

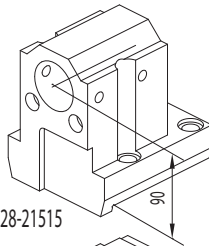

128-21515

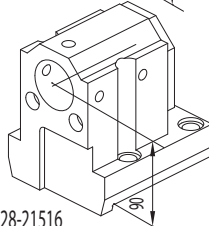

128-21516

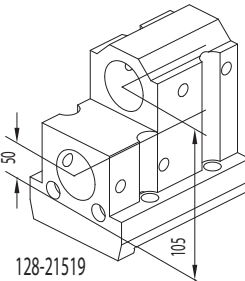

128-21519

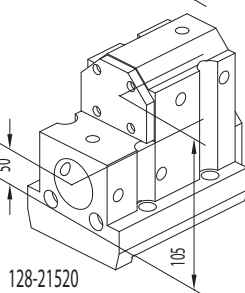

128-21520

Face and O.D. cutting holder

Face and I.D. cutting holder

Cut-off holder

Toolholder for boring bar

Ø40 mm

Combi toolholder for boring bar and insertdrill

Ø40 mm

Double toolholder for boring bar

Ø40 mm

Double combi toolholder for boring bar and insertdrill

Ø40 mm

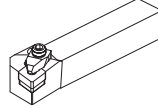

Qualified tool
25x25 mm



Cut-off tool
32 mm
26 mm

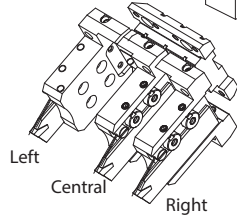

Left

Central

Right



124-06005
124-06006 I.Coolant



124-06007
124-06008 I.Coolant

FAST-IN

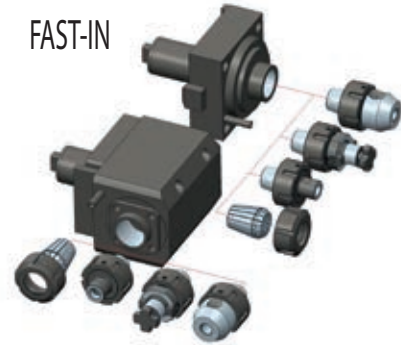

CONNECTION

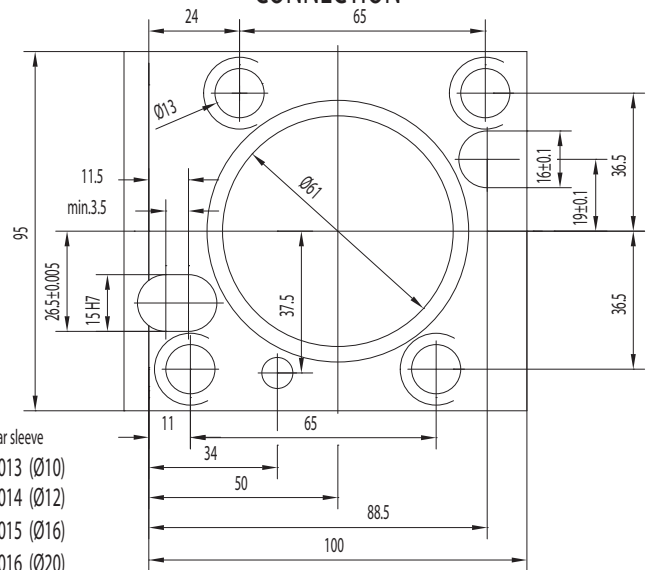

ACCESSORIES

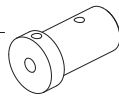

Boring bar sleeve
165-64013 (Ø10)
165-64014 (Ø12)
165-64015 (Ø16)
165-64016 (Ø20)

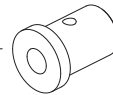

Throw-away drill socket
165-64205 (Ø25)
165-64206 (Ø32)

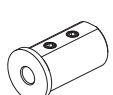

Boring bar sleeve
165-64247 (Ø8)
165-64248 (Ø10)
165-64249 (Ø12)

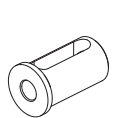

Boring bar sleeve
165-64251 (Ø16)
165-64253 (Ø20)
165-64254 (Ø25)
165-64255 (Ø32)

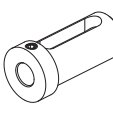

Boring bar sleeve
165-64241 (Ø16)
165-64243 (Ø20)
165-64244 (Ø25)
165-64245 (Ø32)

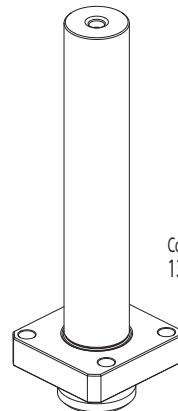

Control pin
137-00195

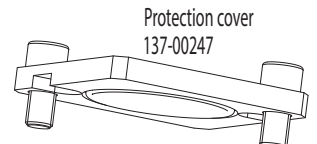

Protection cover
137-00247

CONNECTION

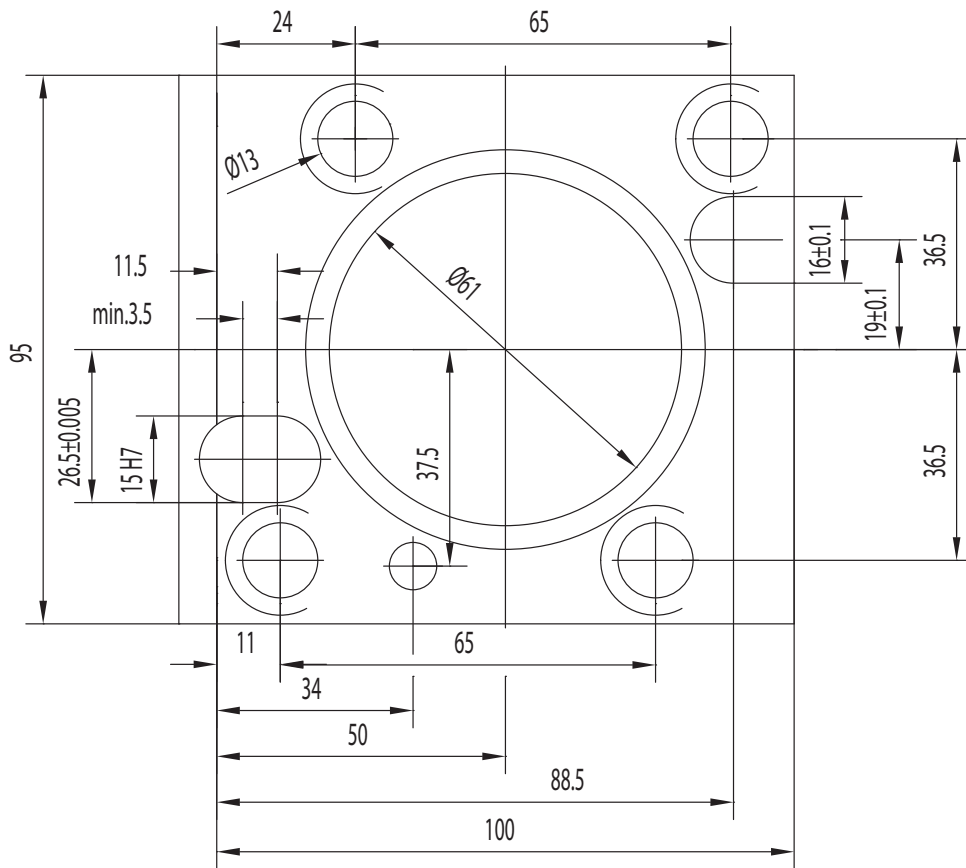



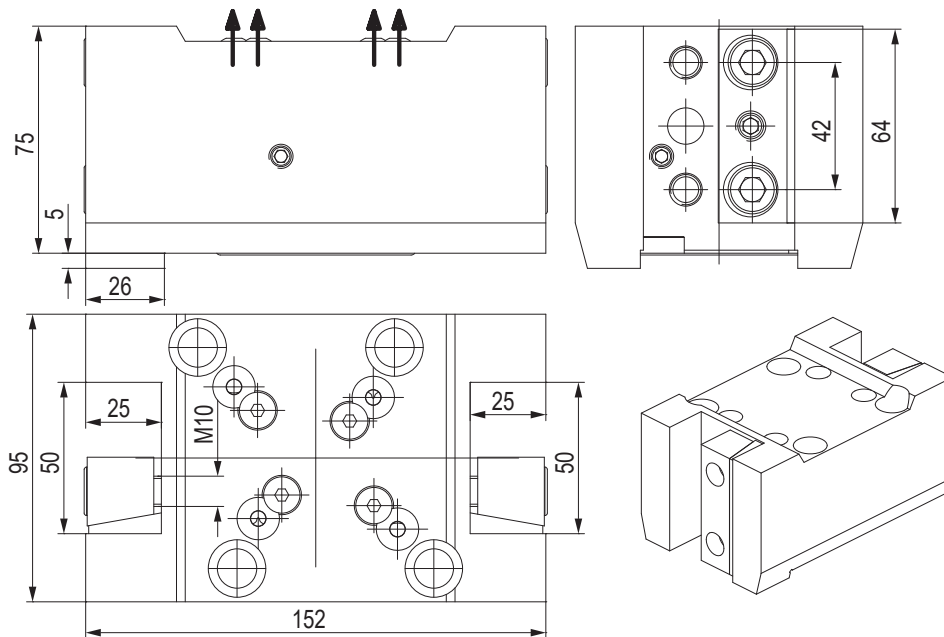

PORTAUTENSILE RADIALE - RADIAL TOOLHOLDERS

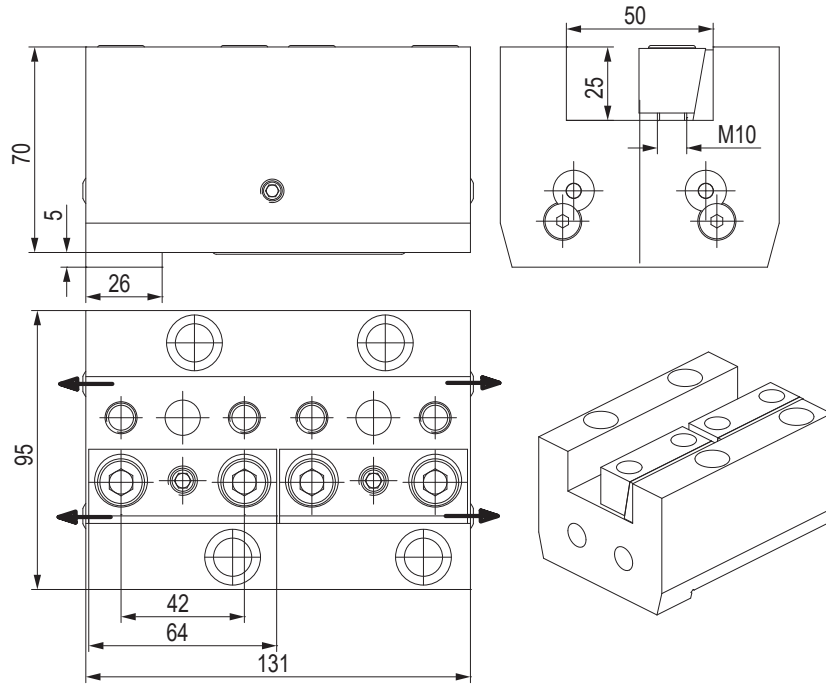

CODE N.	CLAMPING PLATE	COOLANT BALL	SCREW FOR BALL	O RING
128-41509	832-007360	833-001470	811-108018	823-101084

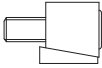

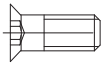

PORTAUTENSILE ASSIALE - AXIAL TOOLHOLDERS

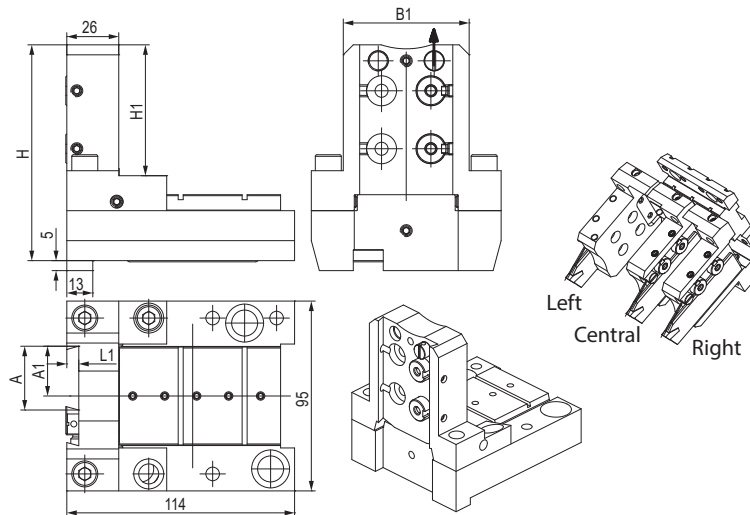

CODE N.	CLAMPING PLATE	COOLANT BALL	SCREW FOR BALL	O RING
128-31505				
128-31505	832-007360	833-001470	811-108018	823-101084

PORTALAMA - CUT-OFF HOLDERS



CODE N.	A	A1	L1	B1	H	H1	COOLANT NOZZLE	O RING FOR COOLANT NOZZLE	O RING FOR BODY	O RING FOR BASE
128-11535	32	25	6	63	108	65.5				
128-11535	32	25	6	63	108	65.5	833-001490	823-101058	823-101061	823-101084

CODE N.	SHIM PLATE	SCREW FOR PLATE	CLAMPING PIN	SPRING	CLAMPING SCREW	SCREW
128-11535						
128-11535	832-014449	811-108037	832-014450	824-300012	811-101028	811-104013

PORTAUTENSILE PER BARENI TOOLHOLDER FOR BORING BAR

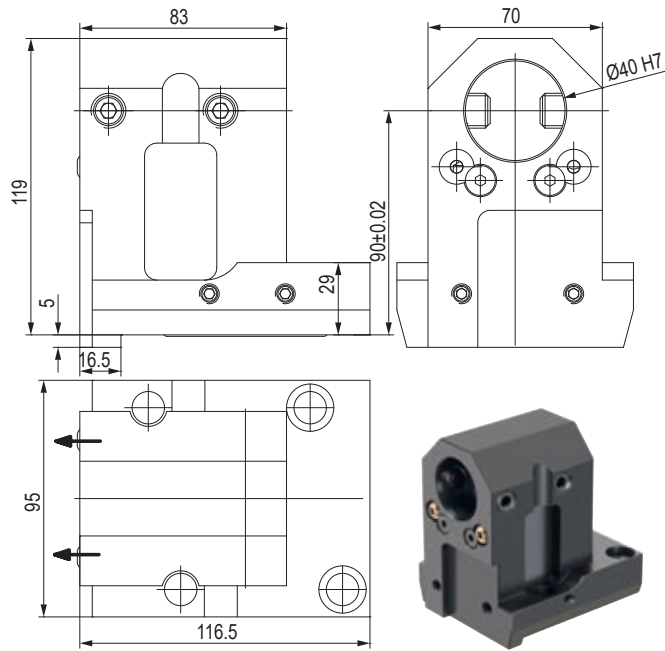

CODE N.	CLAMPING SCREW	COOLANT BALL	SCREW FOR BALL	O RING
128-21515	811-102088	833-001470	811-108018	823-101084

PORTAUTENSILE COMBINATO PER BARENI E PUNTE A INSERTI COMBI TOOLHOLDER FOR BORING BAR AND INSERTDRILL

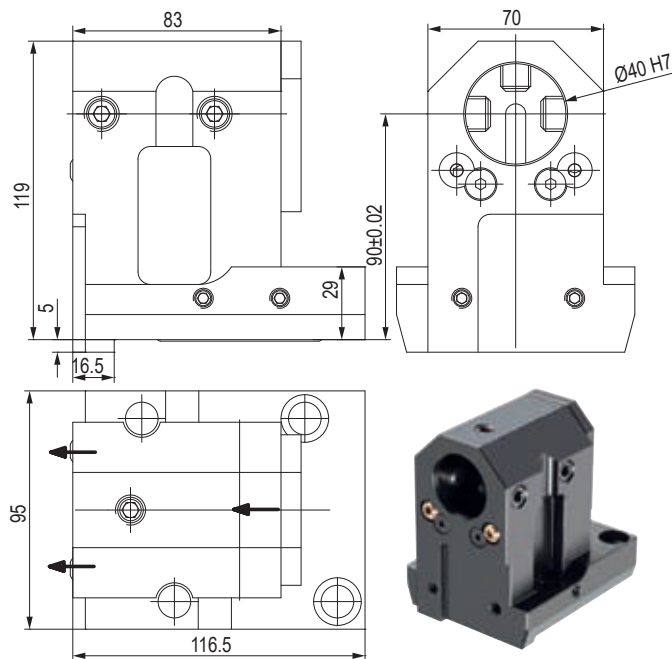

CODE N.	CLAMPING SCREW1 (M14X25)	CLAMPING SCREW2 (M12X20)	COOLANT BALL	SCREW FOR BALL	O RING	COVER	SCREW FOR COVER
128-21516	811-102088	811-102044	833-001470	811-108018	823-101084	832-003297	811-101016

PORTAUTENSILE DOPPIO PER BARENI DOUBLE TOOLHOLDER FOR BORING BAR

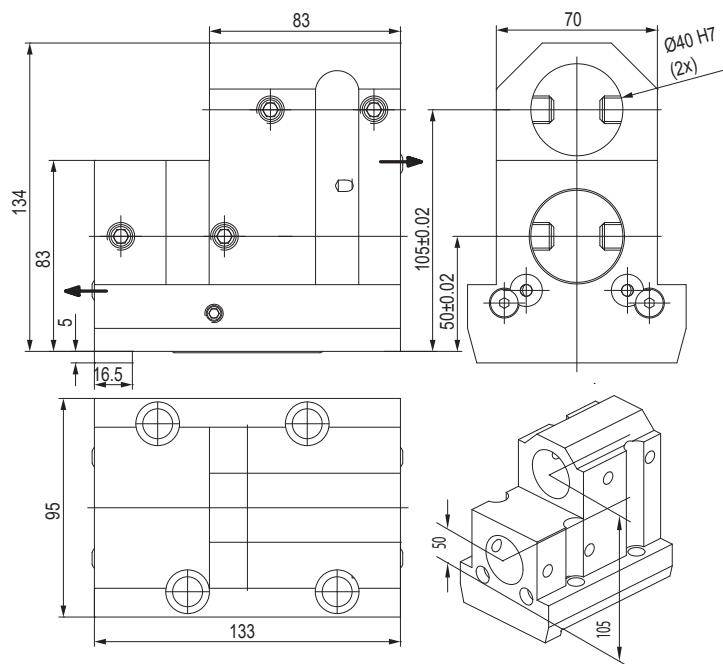

CODE N.	CLAMPING SCREW	COOLANT BALL	SCREW FOR BALL	O RING
128-21519	811-102045	833-001470	811-108018	823-101084

PORTAUTENSILE COMBI PER BARENI E PUNTE A INSERTI COMBI TOOLHOLDER FOR BORING BAR AND INSERTDRILL

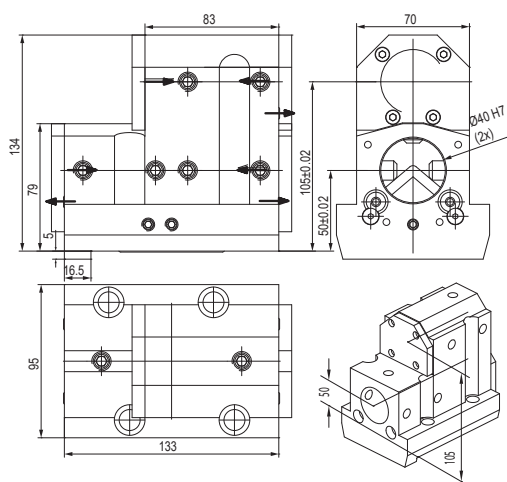

CODE N.	CLAMPING SCREW1 (M12X25)	CLAMPING SCREW2 (M12X12)	COOLANT BALL	SCREW FOR BALL	O RING
128-21520	811-102045	811-102064	833-001410	811-108024	823-101084

CODE N.	COVER1	COVER2	SCREW FOR COVER
128-21520	832-003306	832-003307	811-101016

PORTAUTENSILE MOTORIZZATO ASSIALE STRAIGHT DRILLING AND MILLING HEAD

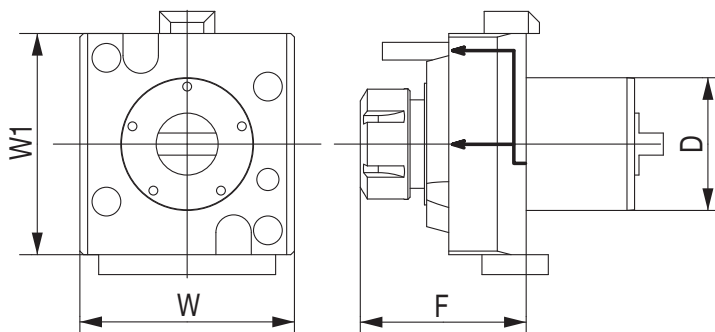

CODE N.	D	ER	INTERNAL COOLING	F	W	W1	TORQUE (Nm)	NMAX (Rpm)	RATIO	P (Bar)
124-06005	60	ER32	no	87	97	100	70	6000	1:1	-
124-06006	60	ER32	yes	87	97	100	70	6000	1:1	20

PORTAUTENSILE MOTORIZZATO RADIALE ANGULAR DRILLING AND MILLING HEAD

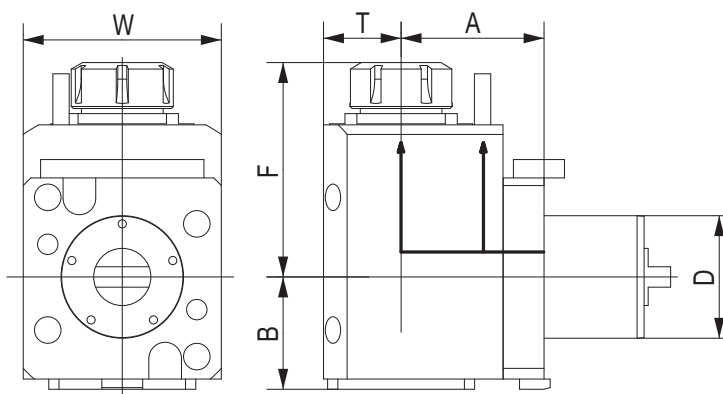
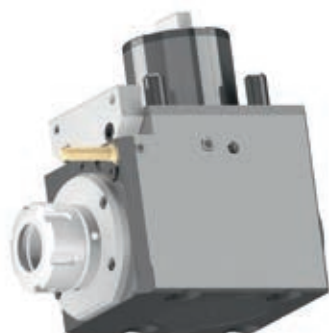

CODE N.	D	ER	INTERNAL COOLING	DIRECTION	A	B	F	T	W	TORQUE (Nm)	NMAX (Rpm)	RATIO	P (Bar)
124-06007	60	ER32	no	right/left	70	59	111	38	94	70	6000	1:1	-
124-06008	60	ER32	yes	right/left	70	59	111	38	94	70	6000	1:1	20

BARRA DI CONTROLLO - CONTROL PIN

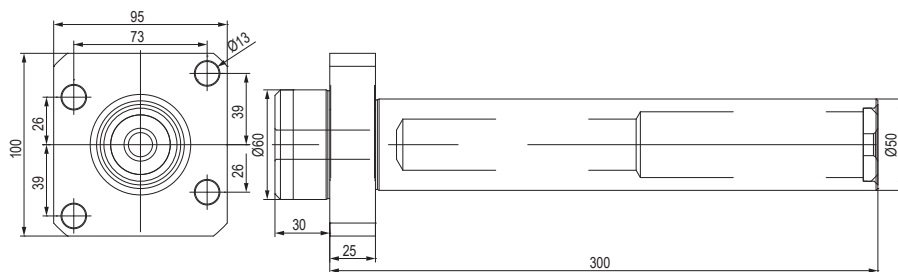
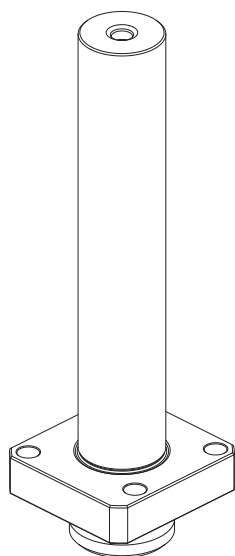

CODE N.

137-00195

TAPPO DI PROTEZIONE - PROTECTION COVER

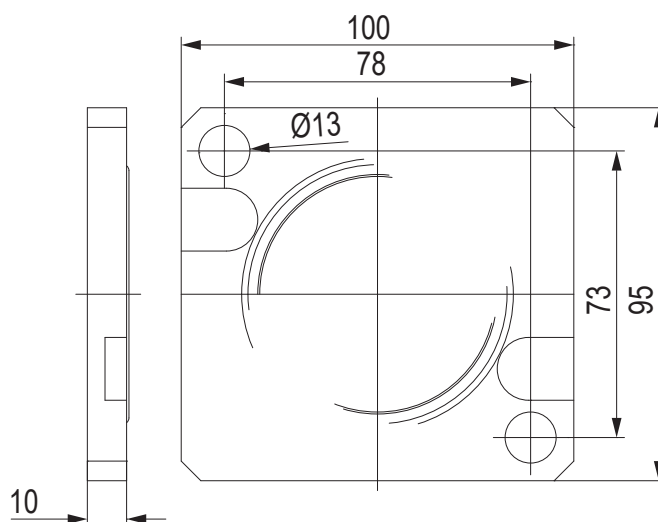
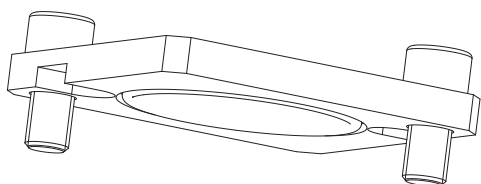

CODE N.

O RING



137-00247

823-101084

BUSSOLA PER PORTABARENI BORING BAR SLEEVE FOR TOOLHOLDER

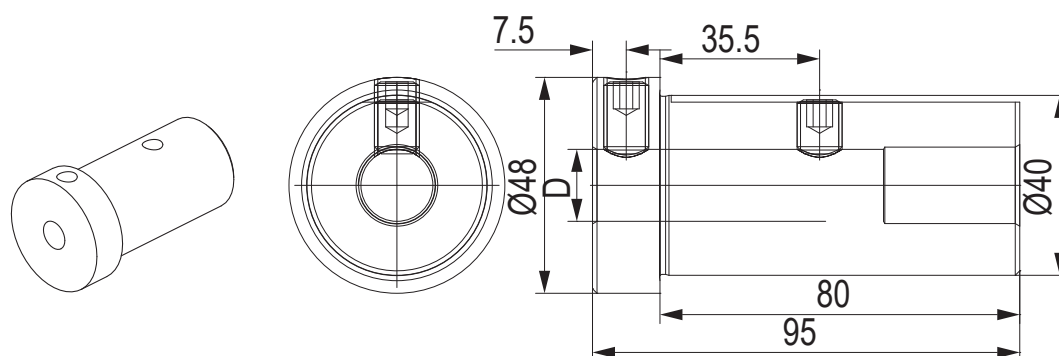

CODE N.	Ø	D	SCREW1 (LONG)	SCREW2 (SHORT)
165-64013	40	10	811-10230	811-10229
165-64014	40	12	811-10237	811-10236
165-64015	40	16	811-10237	811-10236
165-64016	40	20	811-10236	811-10235

BUSSOLA PER PUNTA INSERTI THROW-AWAY DRILL SOCKET FOR TOOLHOLDER

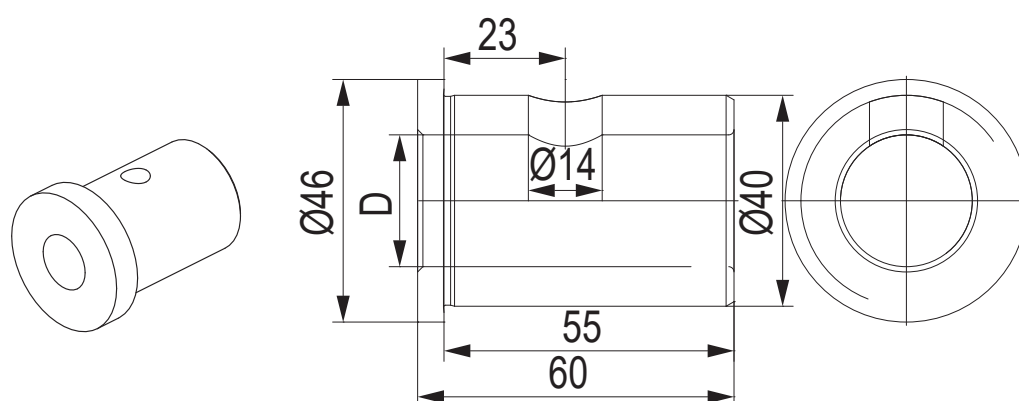

CODE N.	Ø	D
165-64205	40	25
165-64206	40	32

BUSSOLA PER PORTABARENI BORING BAR SLEEVE FOR TOOLHOLDER

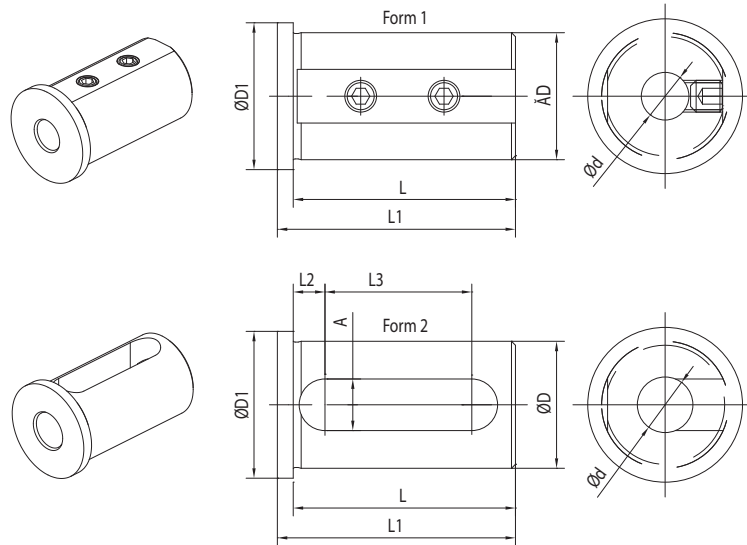

CODE N.	D	d	FORM	L	L1	L2	L3	A	D1
165-64247	40	8	1	71	75	-	-	-	45
165-64248	40	10	1	71	75	-	-	-	45
165-64249	40	12	1	71	75	-	-	-	45
165-64251	40	16	2	71	75	8	52	13	45
165-64253	40	20	2	71	75	8	52	13	45
165-64254	40	25	2	71	75	8	52	13	45
165-64255	40	32	2	71	75	8	52	13	45

BUSSOLA PER PORTABARENI BORING BAR SLEEVE FOR TOOLHOLDER

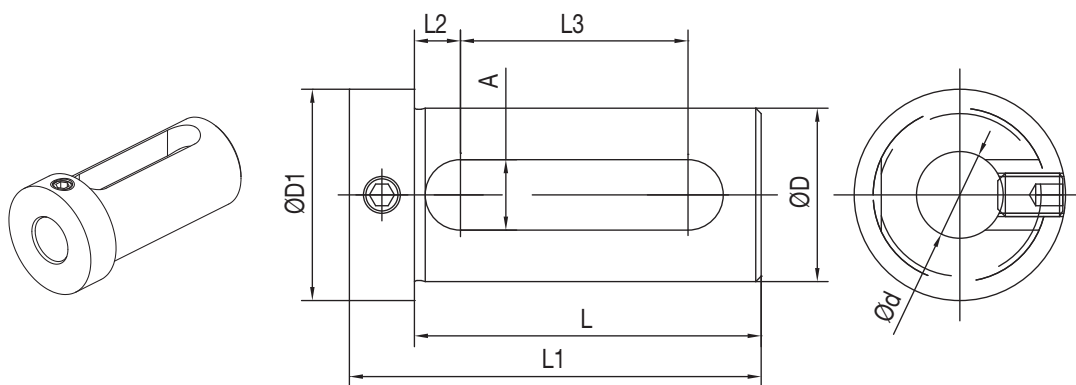

CODE N.	D	d	L	L1	L2	L3	A	D1
165-64241	40	16	74	88	9	51	14	48
165-64243	40	20	74	88	9	51	14	48
165-64244	40	25	74	88	9	51	14	48
165-64245	40	32	74	88	9	51	14	48

OKUMA
(BMT60)

LB4000 EX (M, MY)

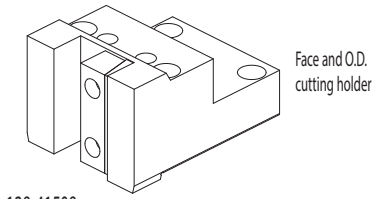

Face and O.D.
cutting holder

128-41508

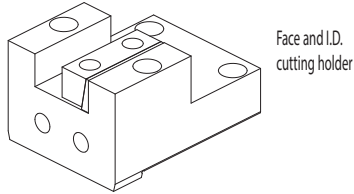

Face and I.D.
cutting holder

128-31504

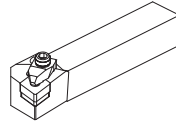

Qualified tool
25x25 mm

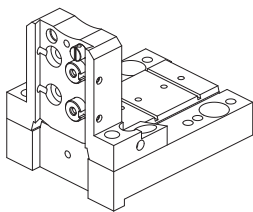

Cut-off holder



Cut-off tool
32 mm

128-11536

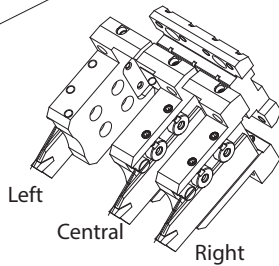

Left

Central

Right

ACCESSORIES

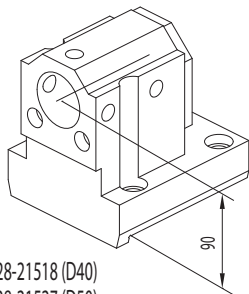

Combi toolholder
for boring bar and
insert drill

128-21518 (D40)
128-21527 (D50)

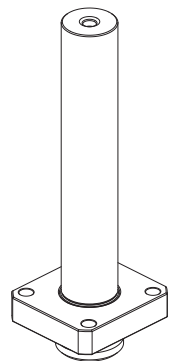

Control pin
137-00196

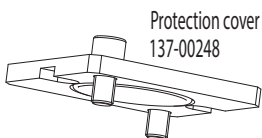

Protection cover
137-00248

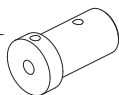

Boring bar sleeve D40
165-64013 (Ø10)
165-64014 (Ø12)
165-64015 (Ø16)
165-64016 (Ø20)

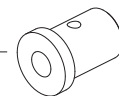

Throw-away drill socket D40
165-64205 (Ø25)
165-64206 (Ø32)

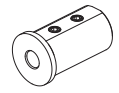

Boring bar sleeve D40
165-64247 (Ø8)
165-64248 (Ø10)
165-64249 (Ø12)

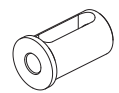

Boring bar sleeve D40
165-64251 (Ø16)
165-64253 (Ø20)
165-64254 (Ø25)
165-64255 (Ø32)

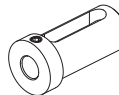

Boring bar sleeve
165-64241 (D40/Ø16)
165-64243 (D40/Ø20)
165-64244 (D40/Ø25)
165-64245 (D40/Ø32)
165-65017 (D50/Ø25)
165-65018 (D50/Ø32)
165-65019 (D50/Ø40)



124-06009 I.Coolant
124-06010 I.Coolant

124-06011 I.Coolant
124-06012 I.Coolant

FAST-IN

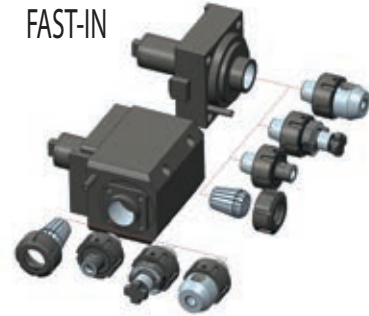

CONNECTION

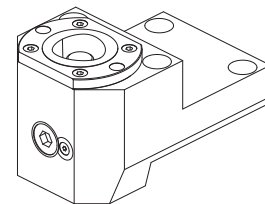
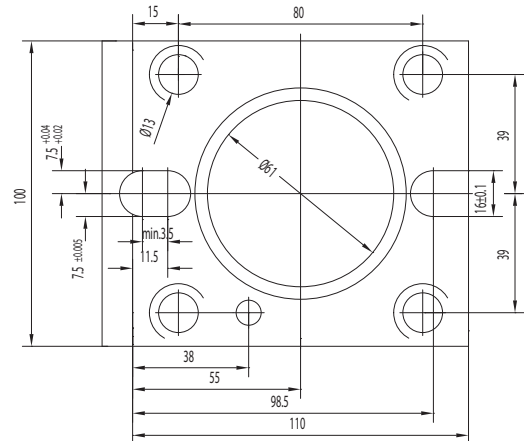

Face and O.D.
cutting holder

Poligonal

128-11570 (C40)
128-11562 (C50)

NEWS

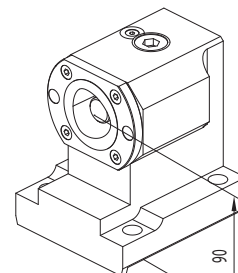

Boring bar holder

Poligonal

128-11569 (C40)
128-11560 (C50)

NEWS

CONNECTION

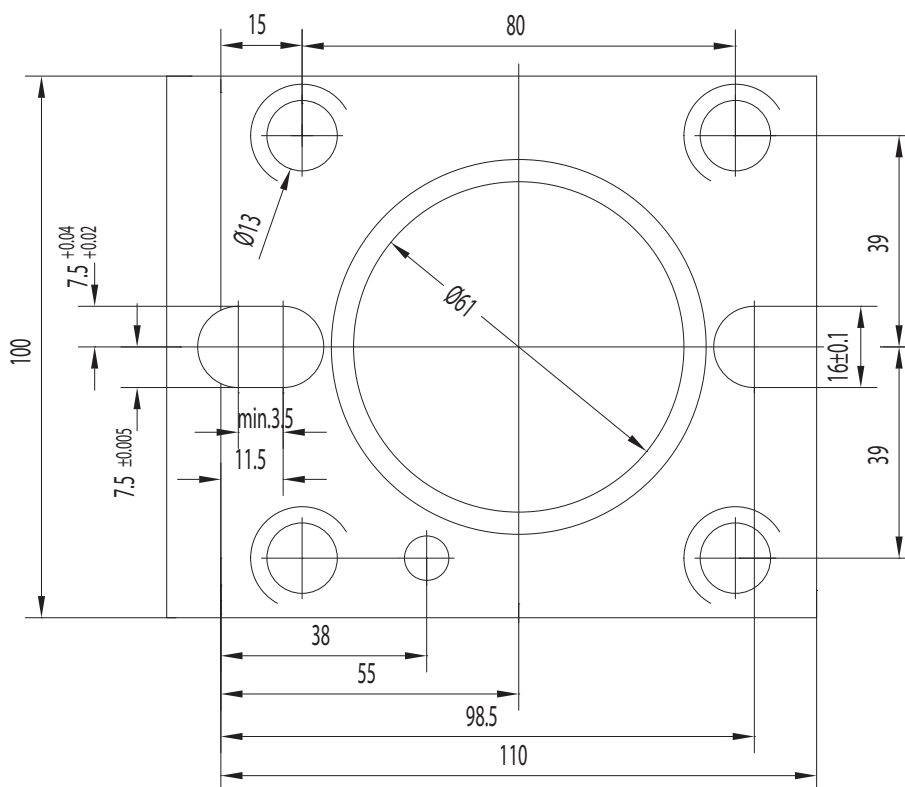



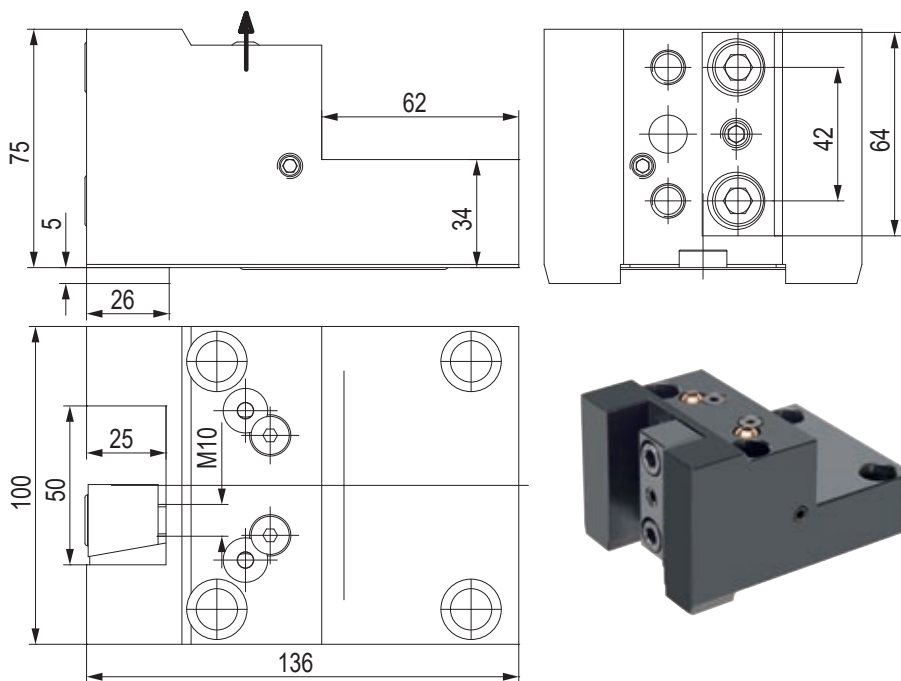

PORTAUTENSILE RADIALE - RADIAL TOOLHOLDERS

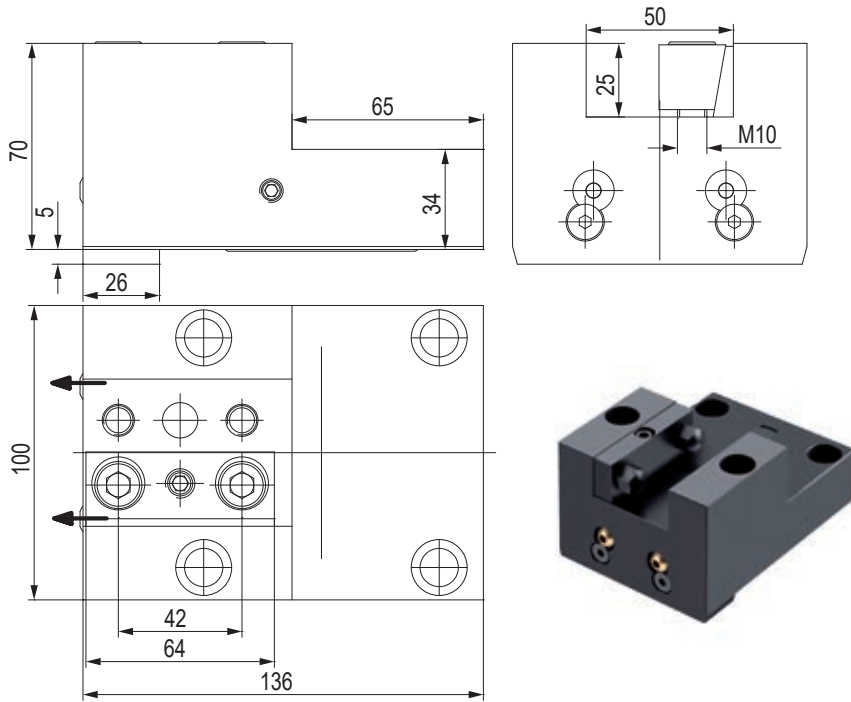

CODE N.	CLAMPING PLATE	COOLANT BALL	SCREW FOR BALL	O RING
128-41508	832-007360	833-001470	811-108018	823-101084

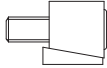
PORTAUTENSILE ASSIALE - AXIAL TOOLHOLDERS

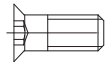

CODE N.	CLAMPING PLATE	COOLANT BALL	SCREW FOR BALL	O RING
128-31504				
128-31504	832-007360	833-001470	811-108018	823-101084

PORTALAMA - CUT-OFF HOLDERS

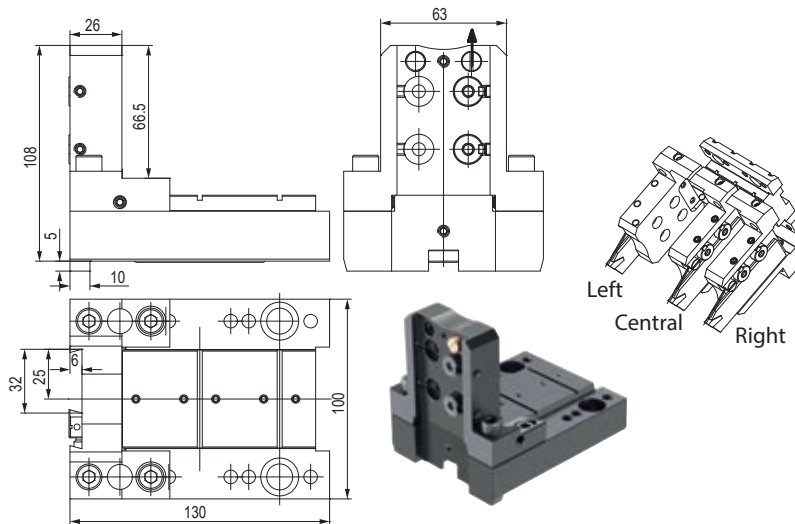

CODE N.	COOLANT NOZZLE	O RING FOR COOLANT NOZZLE	O RING FOR BODY	O RING FOR BASE
128-11536				
128-11536	833-001490	823-101058	823-101061	823-101084

CODE N.	SHIM PLATE	SCREW FOR PLATE	CLAMPING PIN	SPRING	CLAMPING SCREW	SCREW
128-11536						
128-11536	832-014449	811-108037	832-014450	824-300012	811-101028	811-104013

PORTAUTENSILE COMBINATO PER BARENI E PUNTE A INSERTI COMBI TOOLHOLDER FOR BORING BAR AND INSERTDRILL

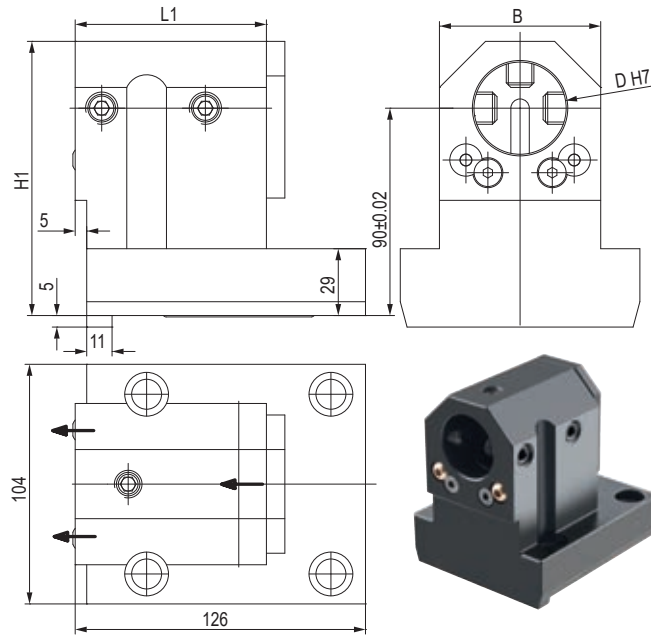

CODE N.	D	B	H1	L1	CLAMPING SCREW1 (M14x25)	CLAMPING SCREW2 (M12X20)	COOLANT BALL	SCREW FOR BALL	O RING	COVER	SCREW FOR COVER
128-21518	40	70	119	83	811-102088	811-102044	833-001470	811-108018	823-101084	832-003297	811-101016
128-21527	50	80	124	93	811-102088	811-102044	833-001470	811-108018	823-101084	832-003314	811-101016

PORTAUTENSILE CON USCITA POLIGONALE POLIGONAL TOOLHOLDERS

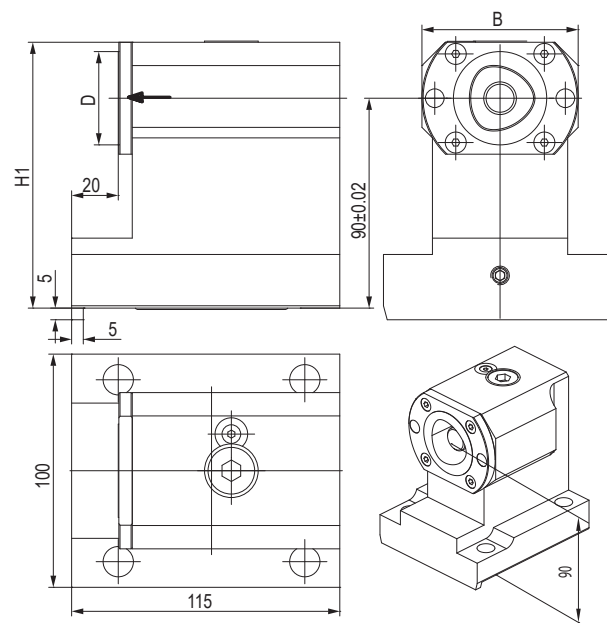

CODE N.	CAPTO	D	H1	B	CLAMPING UNIT	O RING
128-11569	C40	40	114	67	CXC40-10	823-101084
128-11560	C50	50	122	82	CXC50-10	823-101084

PORTAUTENSILE CON USCITA POLIGONALE POLIGONAL TOOLHOLDERS

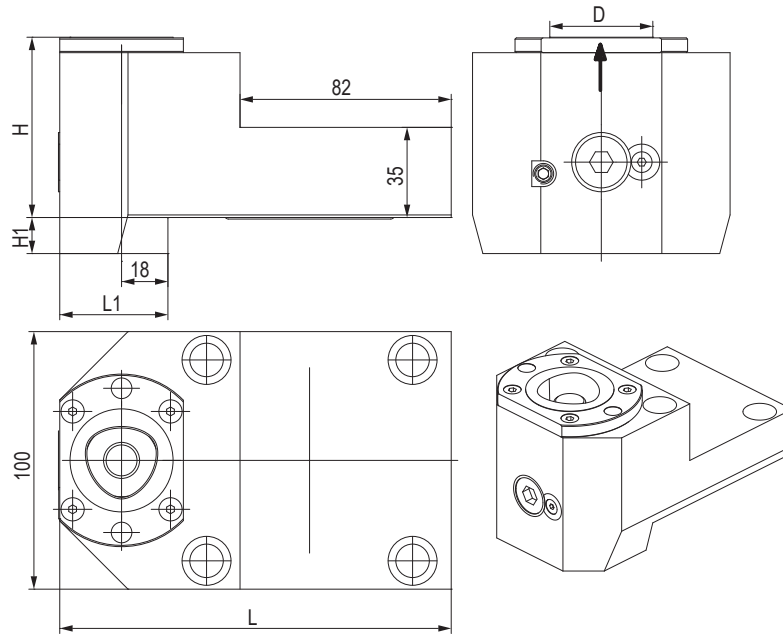

CODE N.	CAPTO	D	H	H1	L	L1	CLAMPING UNIT	O RING
128-11570	C40	40	70	14	152	42	CXC40-10	823-101084
128-11562	C50	50	75	20	160	50	CXC50-10	823-101084



12

PORTAUTENSILE MOTORIZZATO ASSIALE STRAIGHT DRILLING AND MILLING HEAD

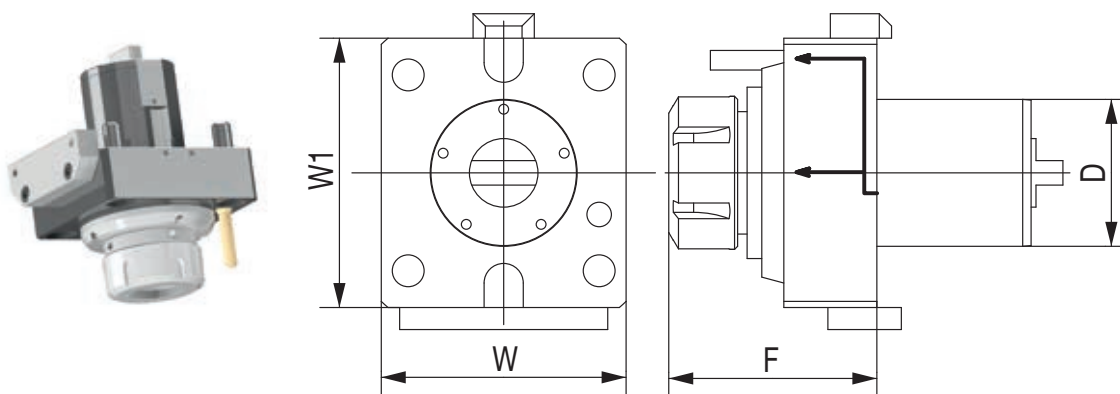

CODE N.	D	ER	INTERNAL COOLING	F	W	W1	TORQUE (Nm)	NMAX (Rpm)	RATIO	P (Bar)
124-06009	60	ER40	no	82	100	110	80	6000	1:1	-
124-06010	60	ER40	yes	82	100	110	80	6000	1:1	20

PORTAUTENSILE MOTORIZZATO RADIALE ANGULAR DRILLING AND MILLING HEAD

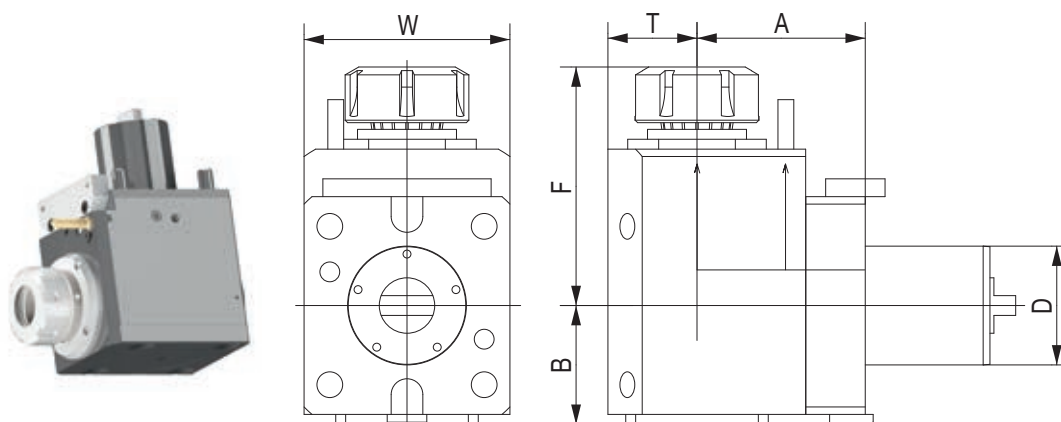

CODE N.	D	ER	INTERNAL COOLING	DIRECTION	A	B	F	T	W	TORQUE (Nm)	NMAX (Rpm)	RATIO	P (Bar)
124-06011	60	ER40	no	right/left	85	64	121	44	100	80	6000	1:1	-
124-06012	60	ER40	yes	right/left	85	64	121	44	100	80	6000	1:1	20

BUSSOLA PER PORTABARENI BORING BAR SLEEVE FOR TOOLHOLDER

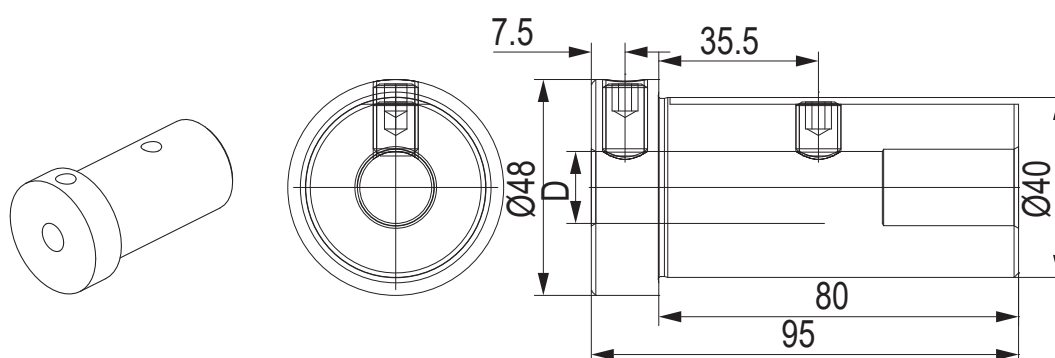

CODE N.	Ø	D	SCREW1 (LONG)	SCREW2 (SHORT)
165-64013	40	10	811-10230	811-10229
165-64014	40	12	811-10237	811-10236
165-64015	40	16	811-10237	811-10236
165-64016	40	20	811-10236	811-10235

BUSSOLA PER PUNTA INSERTI THROW-AWAY DRILL SOCKET FOR TOOLHOLDER

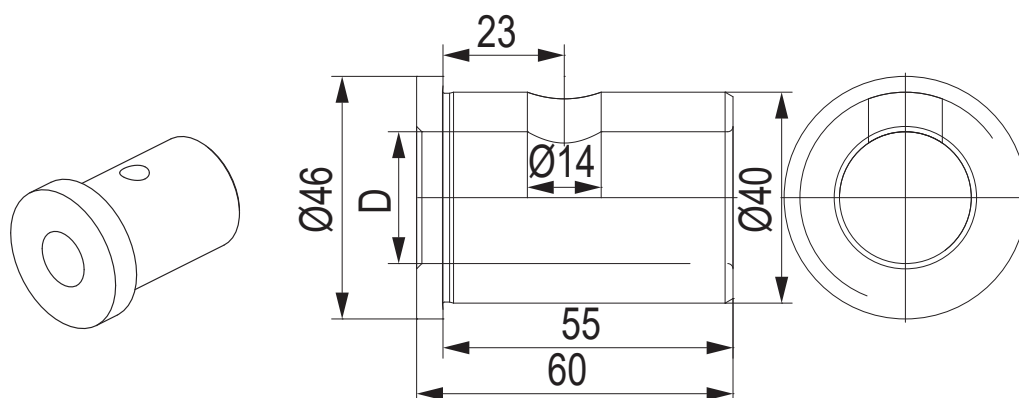

CODE N.	Ø	D
165-64205	40	25
165-64206	40	32

BUSSOLA PER PORTABARENI BORING BAR SLEEVE FOR TOOLHOLDER

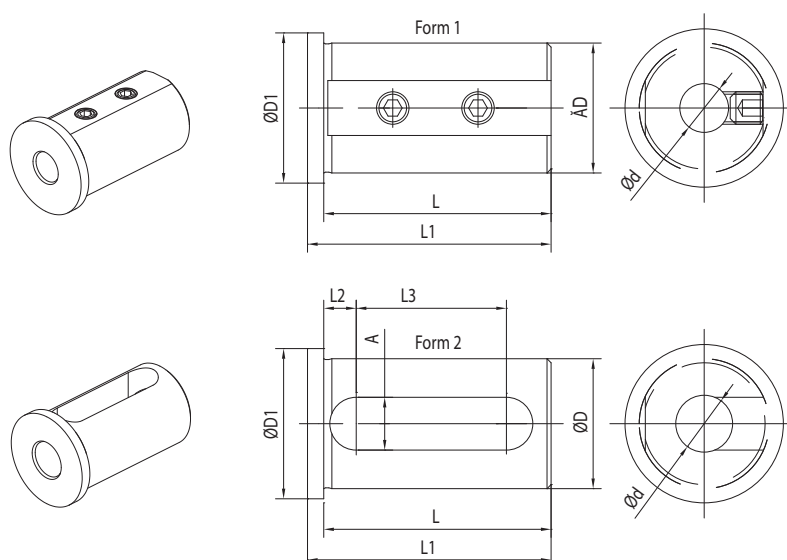

CODE N.	D	d	FORM	L	L1	L2	L3	A	D1
165-64247	40	8	1	71	75	-	-	-	45
165-64248	40	10	1	71	75	-	-	-	45
165-64249	40	12	1	71	75	-	-	-	45
165-64251	40	16	2	71	75	8	52	13	45
165-64253	40	20	2	71	75	8	52	13	45
165-64254	40	25	2	71	75	8	52	13	45
165-64255	40	32	2	71	75	8	52	13	45

BUSSOLA PER PORTABARENI BORING BAR SLEEVE FOR TOOLHOLDER

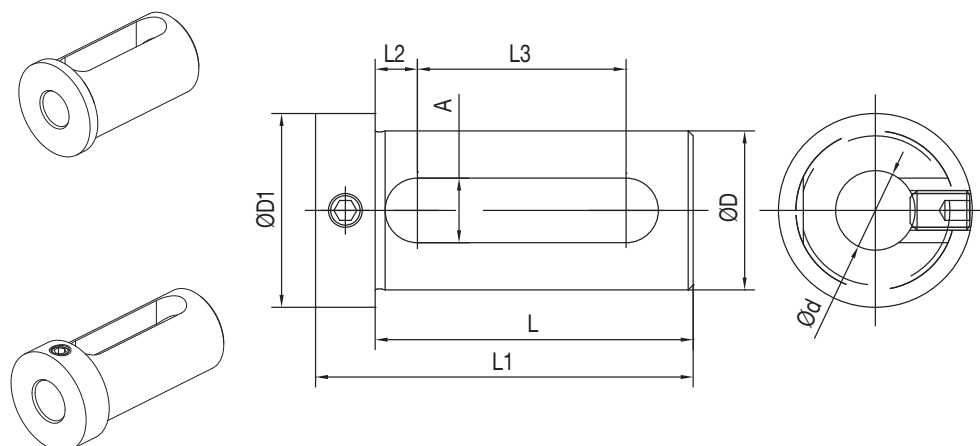

CODE N.	D	d	L	L1	L2	L3	A	D1
165-64241	40	16	75	89	9	51	14	48
165-64243	40	20	75	89	9	51	14	48
165-64244	40	25	75	89	9	51	14	48
165-64245	40	32	75	89	9	51	14	48
165-65017	50	25	85	99	9	61	14	60
165-65018	50	32	85	99	9	61	14	60
165-65019	50	40	85	99	9	61	14	60



NAKAMURA TOME (BMT44)

NTY3/ SUPER NTMX/NTMXL / WT100
MURATA MURATEC MT100
WY-100II / NTJ100

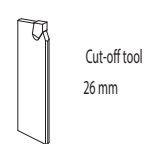
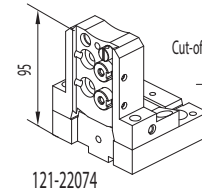
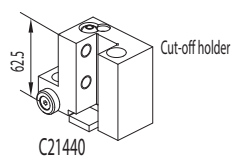
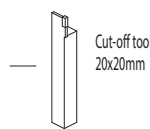
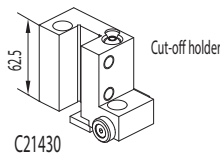
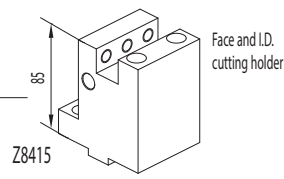
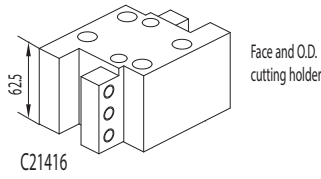
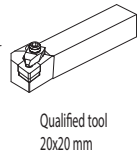
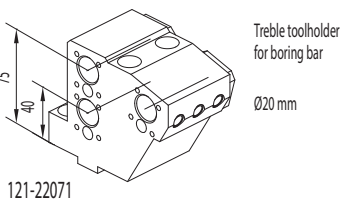
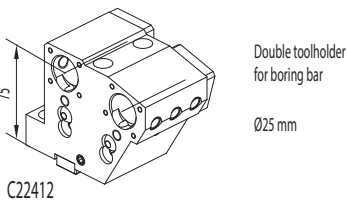
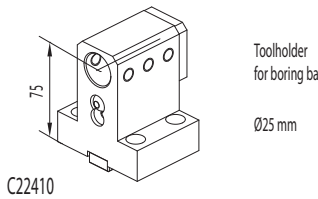
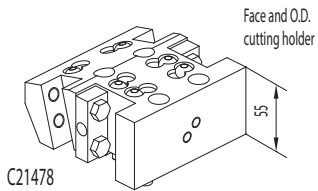
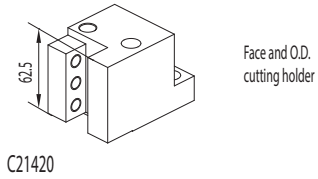
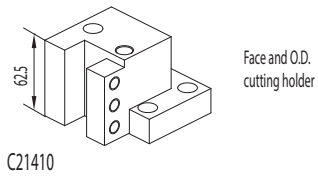

ACCESSORIES

Boring bar sleeve
165-62551 (Ø8)
165-62552 (Ø10)
165-62553 (Ø12)

Boring bar sleeve
165-62555 (Ø16)

Boring bar sleeve
165-62545 (Ø12)
165-62547 (Ø16)
165-62549 (Ø20)

Boring bar sleeve
E2-1 20x6
E2-1 20x8
E2-1 20x10
E2-1 20x12

FAST-IN



124-04401
124-04402 I.Coolant

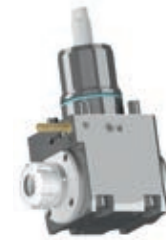

124-04403
124-04404 I.Coolant

CONNECTION

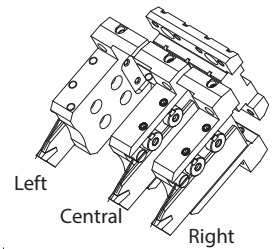
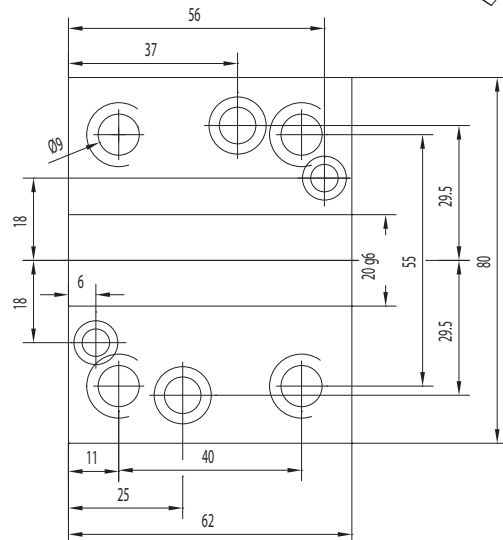

CONNECTION

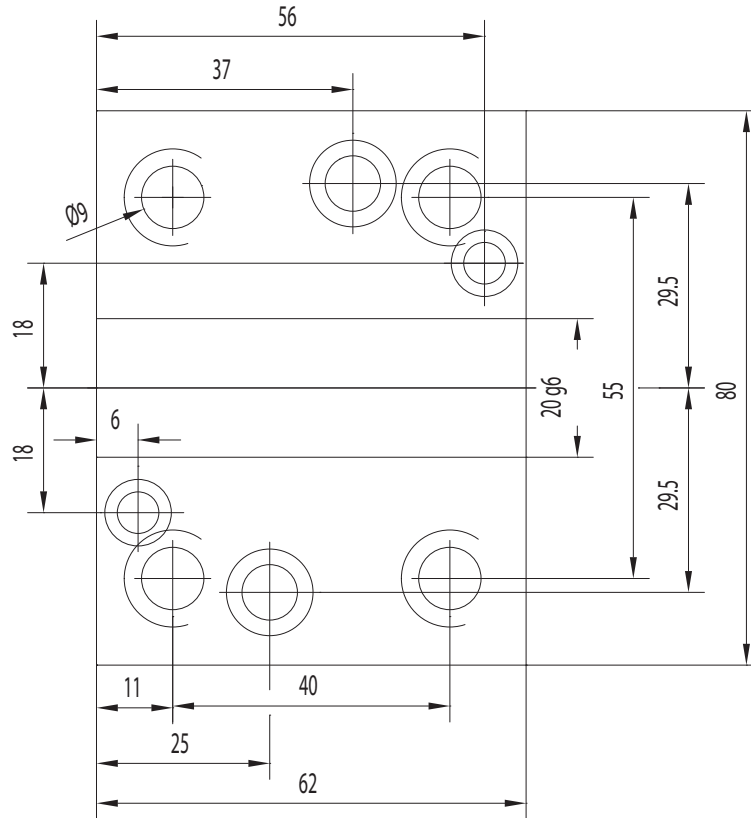

PORTAUTENSILE RADIALE - RADIAL TOOLHOLDERS

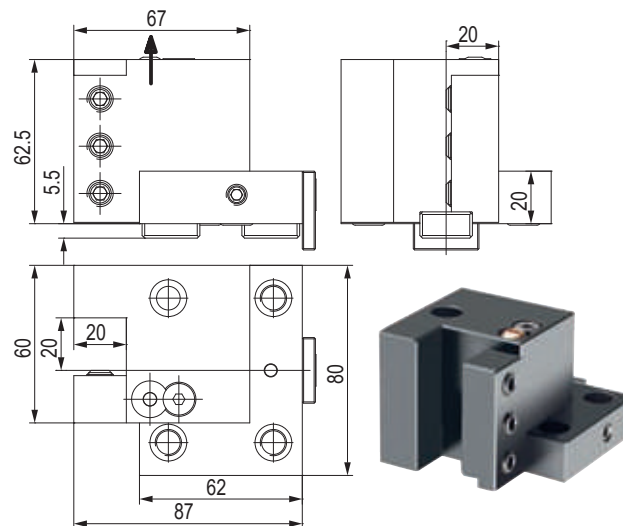

CODE N.	CLAMPING SCREW	KEY	SCREW FOR KEY	COOLANT BALL	SCREW FOR BALL
C21410	811-102038	814-203270	811-101027	833-001470	811-108018

CODE N.	STOP PLATE	SCREW FOR PLATE	O RING FOR COOLANT INTAKE
C21410	832-003232	811-108029	823-101083

PORTAUTENSILE RADIALE - RADIAL TOOLHOLDERS

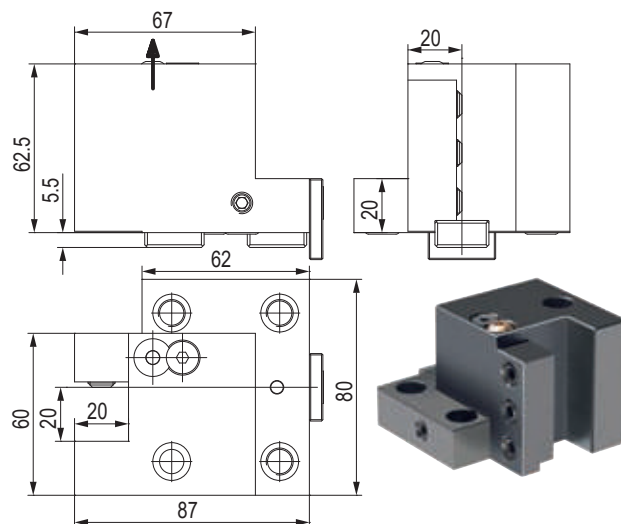

CODE N.	CLAMPING SCREW	KEY	SCREW FOR KEY	COOLANT BALL	SCREW FOR BALL
C21420	811-102038	814-203270	811-101027	833-001470	811-108018

CODE N.	STOP PLATE	SCREW FOR PLATE	O RING FOR COOLANT INTAKE
C21420	832-003232	811-108029	823-101083

PORTAUTENSILE RADIALE - RADIAL TOOLHOLDERS

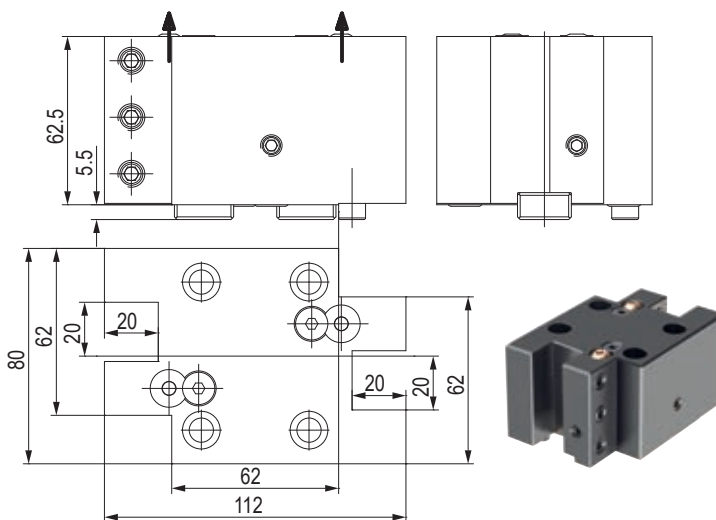

CODE N.	CLAMPING SCREW	KEY	SCREW FOR KEY	COOLANT BALL	SCREW FOR BALL
C21416	811-102038	814-203270	811-101027	833-001470	811-108018

CODE N.	STOP SCREW	O RING FOR COOLANT INTAKE
C21416	811-101026	823-101083

PORTAUTENSILE RADIALE - RADIAL TOOLHOLDERS

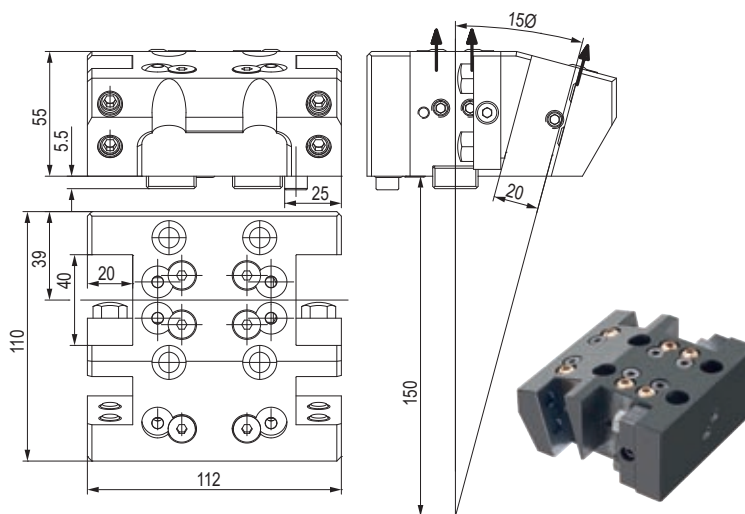

CODE N.	CLAMPING SCREW1	CLAMPING SCREW2	CLAMPING PLATE	SCREW FOR PLATE	KEY	SCREW FOR KEY
C21478	811-102037	811-301108	832-002184	811-101019	814-203270	811-101027

CODE N.	STOP SCREW	COOLANT BALL	SCREW FOR BALL	O RING FOR COOLANT INTAKE1 (d7.59X2.62)	O RING FOR COOLANT INTAKE2 (d6X2)
C21478	811-101026	833-001470	811-108018	823-101083	823-101082

PORTAUTENSILE ASSIALE - AXIAL TOOLHOLDERS

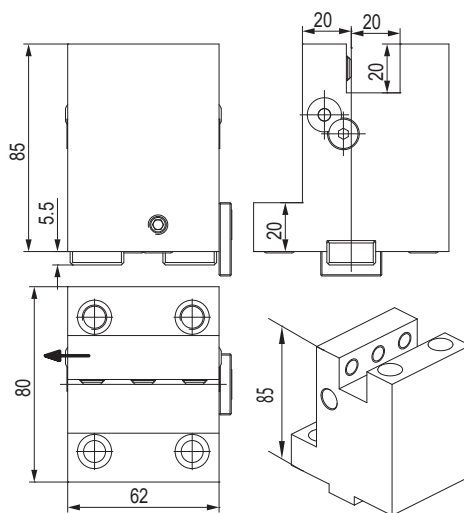

CODE N.	CLAMPING SCREW	KEY	SCREW FOR KEY	COOLANT BALL	SCREW FOR BALL
Z8415	811-102038	814-203270	811-101027	833-001470	811-108018

CODE N.	STOP PLATE	SCREW FOR PLATE	O RING FOR COOLANT INTAKE
Z8415	832-003232	811-108029	823-101083

PORTALAMA - CUT-OFF HOLDERS

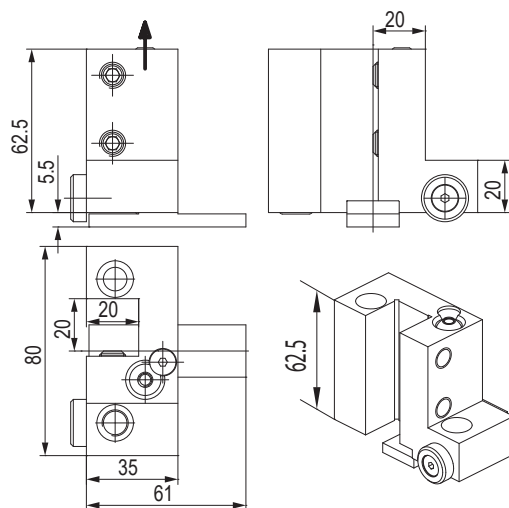

CODE N.	CLAMPING SCREW	KEY	SCREW FOR KEY	COOLANT BALL	SCREW FOR BALL
C21430	811-102038	814-203330	811-101027	833-001410	811-108024

CODE N.	STOP RING	SCREW FOR RING	O RING FOR COOLANT INTAKE
C21430	832-003292	811-108024	823-101083

PORTALAMA - CUT-OFF HOLDERS

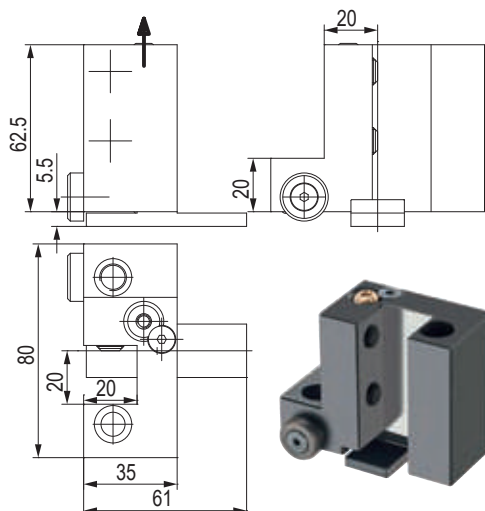

CODE N.	CLAMPING SCREW	KEY	SCREW FOR KEY	COOLANT BALL	SCREW FOR BALL
C21440	811-102038	814-203330	811-101027	833-001410	811-108024

CODE N.	STOP RING	SCREW FOR RING	O RING FOR COOLANT INTAKE
C21440	832-003292	811-108024	823-101083

PORTALAMA - CUT-OFF HOLDERS

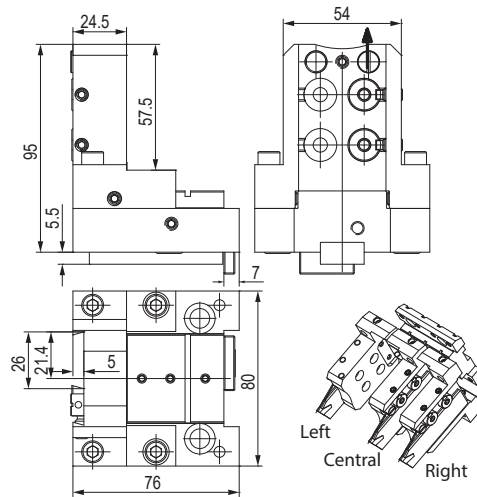

CODE N.	KEY	SCREW FOR KEY	COOLANT NOZZLE	O RING FOR COOLANT NOZZLE	O RING FOR BODY
121-22074	814-203380	811-101011	833-001490	823-101058	823-101061

CODE N.	SHIM PLATE	SCREW FOR PLATE	CLAMPING PIN	SPRING	CLAMPING SCREW	SCREW
121-22074	832-014448	811-108037	832-014447	824-300012	811-101028	811-104013

CODE N.	STOP PLATE	SCREW FOR PLATE	O RING FOR COOLANT INTAKE
121-22074	832-003232	811-108029	823-101083

PORTAUTENSILE PER BARENI - TOOLHOLDER FOR BORING BAR

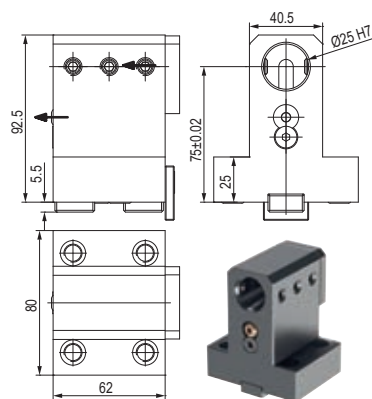

CODE N.	CLAMPING SCREW	KEY	SCREW FOR KEY	COOLANT BALL	SCREW FOR BALL
C22410	811-102035	814-203270	811-101027	833-001470	811-108018

CODE N.	COVER	SCREW FOR COVER	STOP PLATE	SCREW FOR PLATE	O RING FOR COOLANT INTAKE
C22410	832-003291	811-101016	832-003232	811-108029	823-101083

PORTAUTENSILE DOPPIO PER BARENI DOUBLE TOOLHOLDER FOR BORING BAR

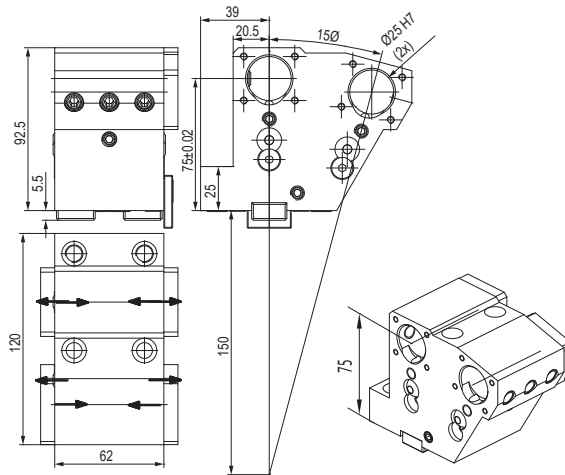

CODE N.	CLAMPING SCREW	KEY	SCREW FOR KEY	COOLANT BALL	SCREW FOR BALL	SCREW FOR INTERNAL COOLANT (M8X12)
C22412	811-102035	814-203270	811-101027	833-001470	811-108018	811-102028

CODE N.	COVER	SCREW FOR COVER	STOP PLATE	SCREW FOR PLATE	O RING FOR COOLANT INTAKE1 (D7.59X2.62)	O RING FOR COOLANT INTAKE2 (D6X2)
C22412	832-003280	811-101010	832-003232	811-108029	823-101083	823-101082

PORTAUTENSILE TRIPLO PER BARENI TREBLE TOOLHOLDER FOR BORING BAR

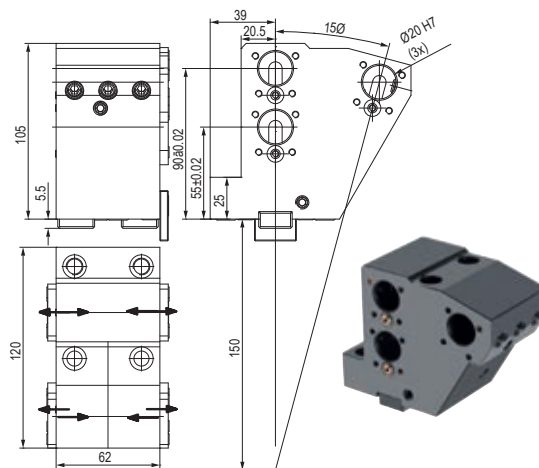

CODE N.	CLAMPING SCREW	KEY	SCREW FOR KEY	COOLANT NOZZLE
121-22071	811-102035	814-203270	811-101026	833-001070

CODE N.	COVER	SCREW FOR COVER	STOP PLATE	SCREW FOR PLATE	O RING FOR COOLANT INTAKE1 (D7.59X2.62)	O RING FOR COOLANT INTAKE2 (D6X2)
121-22071	832-003317	811-101010	832-003232	811-108029	823-101083	823-101082

PORTAUTENSILE MOTORIZZATO ASSIALE STRAIGHT DRILLING AND MILLING HEAD

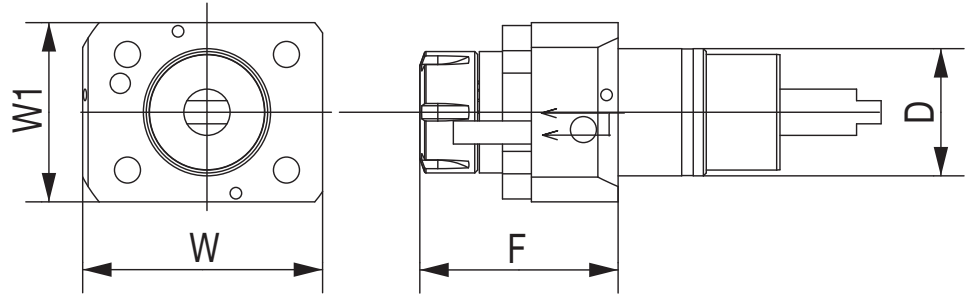

CODE N.	D	ER	INTERNAL COOLING	F	W	W1	TORQUE (Nm)	NMAX (Rpm)	RATIO	P (bar)
124-04401	44	ER25	no	68.6	83	62	40	6000	1:1	-
124-04402	44	ER25	yes	68.6	83	62	40	6000	1:1	20

PORTAUTENSILE MOTORIZZATO RADIALE ANGULAR DRILLING AND MILLING HEAD

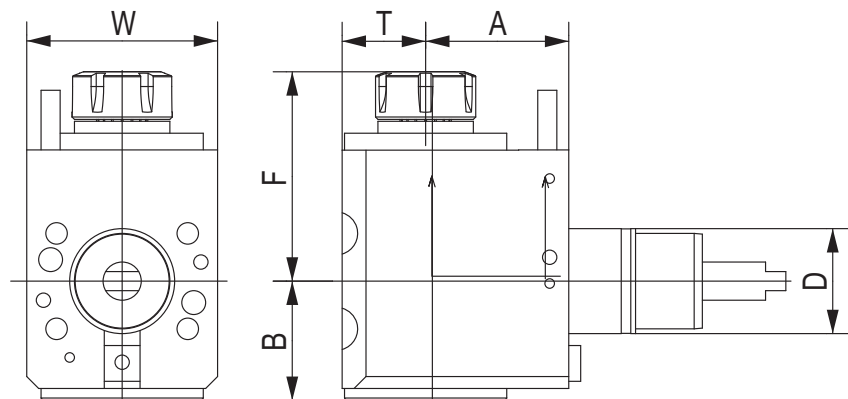
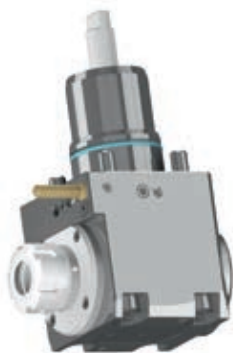

CODE N.	D	ER	INTERNAL COOLING	DIRECTION	A	B	F	T	W	TORQUE (Nm)	NMAX (Rpm)	RATIO	P (Bar)
124-04403	44	ER25	no	right/left	60	50,3	87,8	35	80	28	6000	1:1	-
124-04404	44	ER25	yes	right/left	60	50,3	87,8	35	80	28	6000	1:1	20

TAPPO DI PROTEZIONE - PROTECTION COVER

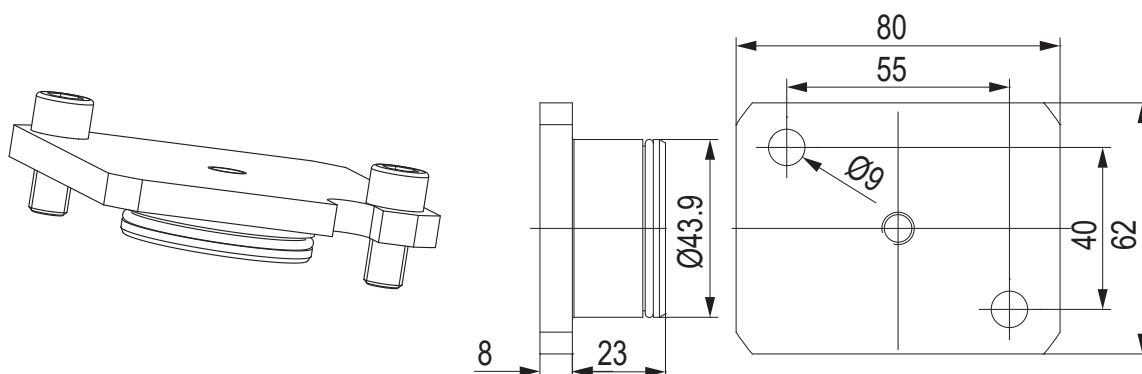

CODE N.	O RING
---------	--------



137-00251	823-101066
-----------	------------

BUSSOLA PER PORTABARENI BORING BAR SLEEVE FOR TOOLHOLDER

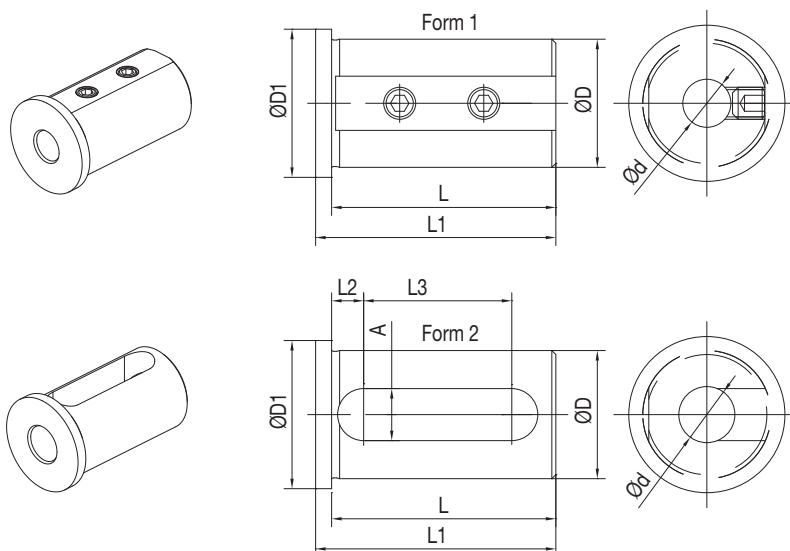

CODE N.	D	d	FORM	L	L1	L2	L3	A	D1
165-62551	25	8	1	46	50	-	-	-	30
165-62552	25	10	1	46	50	-	-	-	30
165-62553	25	12	1	46	50	-	-	-	30
165-62555	25	16	2	46	50	8	27	13	30

BUSSOLA PER PORTABARENI BORING BAR SLEEVE FOR TOOLHOLDER

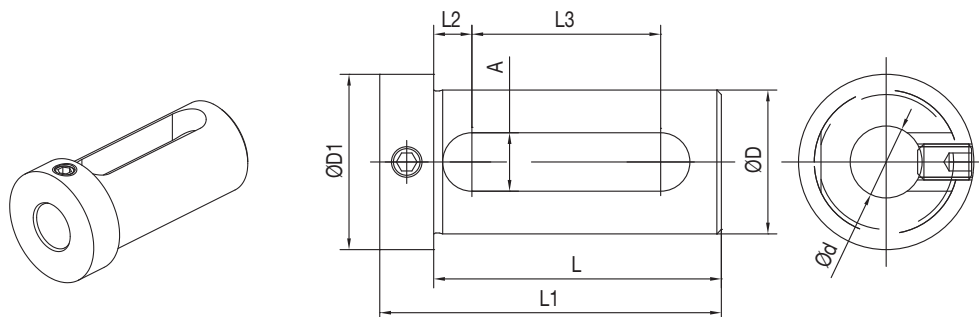

CODE N.	D	d	L	L1	L2	L3	A	D1
165-62545	25	12	54	66	8,5	32	13	32
165-62547	25	16	54	66	8,5	32	13	32
165-62549	25	20	54	66	8,5	32	13	32

BUSSOLA PER PORTABARENI BORING BAR SLEEVE FOR TOOLHOLDER

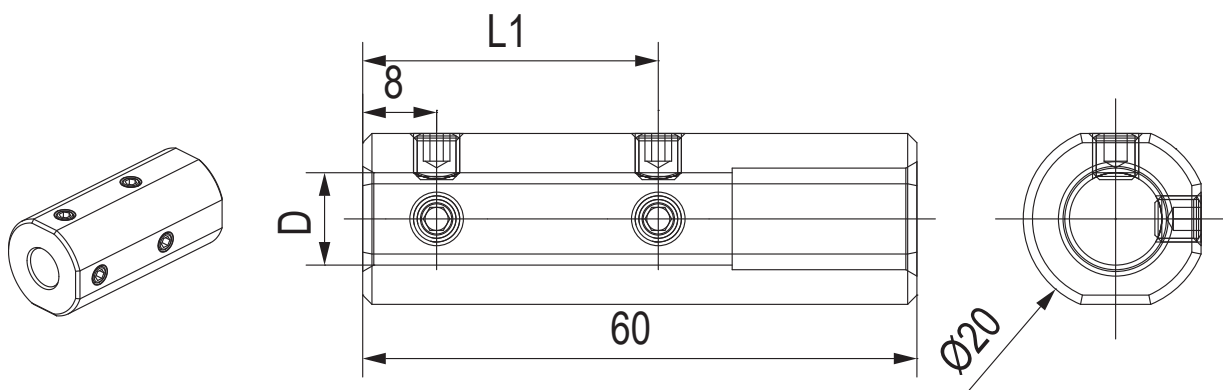

CODE N.	D	L1	SCREW
E2-1 20x6	6	27	811-102010
E2-1 20x8	8	27	811-102010
E2-1 20x10	10	32	811-102009
E2-1 20x12	12	32	811-102063

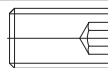

NAKAMURA TOME (BMT55)

AS-200 / NTM 3 / NTY3-250
 SC-150M / SC-200MY / SC-250M / SuperNTJ
 TMC-20 II M/ML / TW-10 / TW-20
 WT-20 II M/MY / WT150/200 / WT-250
 WTS-150 / WTW-150/160 / WT200 II (M,MY)
 WY-250 / CMZ TX52/66
 SUPER NTJ/NTM3 / SC150/250

CMZ TX52/66

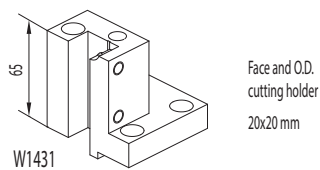

W1431

Face and O.D. cutting holder
20x20 mm

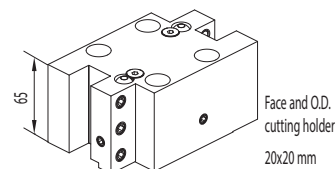

123-12063

Face and O.D. cutting holder
20x20 mm

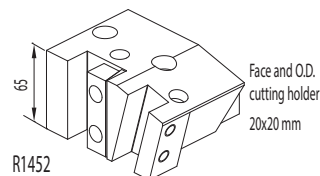

R1452

Face and O.D. cutting holder
20x20 mm

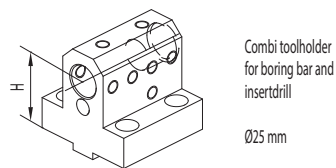

Combi toolholder for boring bar and insertdrill
Ø25 mm

W1417 D25 (H=55 mm)
 W4437 D25 (H=75 mm)
 G1417 D25 (H=85 mm)

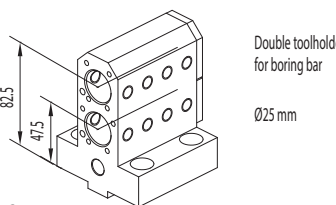

Double toolholder for boring bar
Ø25 mm

R8418

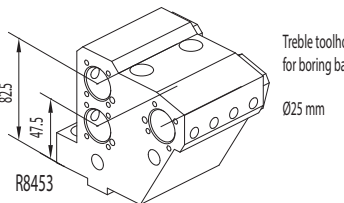

Treble toolholder for boring bar
Ø25 mm

R8453

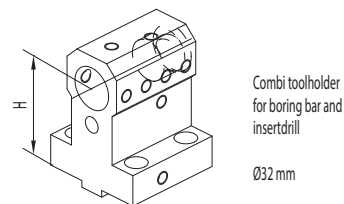

Combi toolholder for boring bar and insertdrill
Ø32 mm

W1417 D32 (H=55 mm)
 Z2417 D32 (H=70 mm)
 Z7417 D32 (H=80 mm)

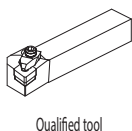

Qualified tool

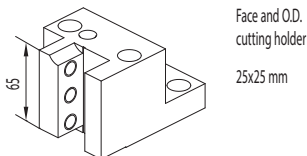

Z2414

Face and O.D. cutting holder
25x25 mm

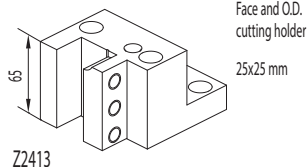

Z2413

Face and O.D. cutting holder
25x25 mm

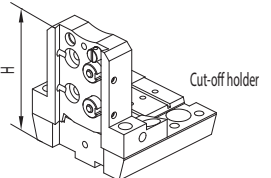

Cut-off holder

121-22076 (h=32 mm H=100 mm)

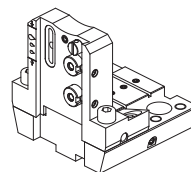

121-22076-IC I.Coolant

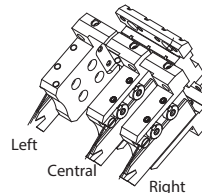

Left
Central
Right

FAST-IN



124-05507
124-05508 I.Coolant



124-05509
124-05510 I.Coolant

ACCESSORIES

Boring bar sleeve D25
 165-62551 (Ø8)
 165-62552 (Ø10)
 165-62553 (Ø12)

Boring bar sleeve D32
 165-63352 (Ø8)
 165-63353 (Ø10)
 165-63354 (Ø12)

Boring bar sleeve D25
 165-62555 (Ø16)
 Boring bar sleeve D32
 165-63356 (Ø16)
 165-63358 (Ø20)
 165-63359 (Ø25)

Boring bar sleeve D25
 165-62545 (Ø12)
 165-62547 (Ø16)
 165-62549 (Ø20)

Boring bar sleeve D32
 165-63347 (Ø16)
 165-63349 (Ø20)
 165-63350 (Ø25)

Boring bar sleeve D25
 115-62573 (Ø6)
 115-62538 (Ø8)
 115-62539 (Ø10)
 115-62540 (Ø12)

Boring bar sleeve D25
 115-62541 (Ø16)

Protection cover
137-00249

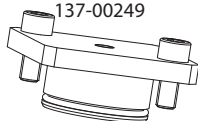

CONNECTION

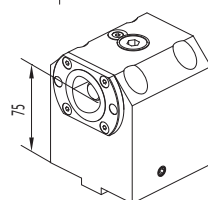
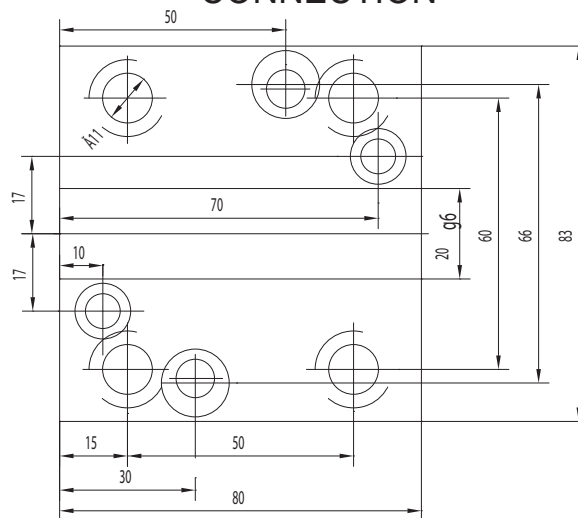

Boring bar holder
Polygonal C40

121-22098

NEWS

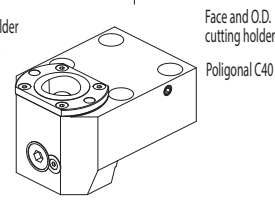

Face and O.D. cutting holder
Polygonal C40

121-22099

NEWS

CONNECTION

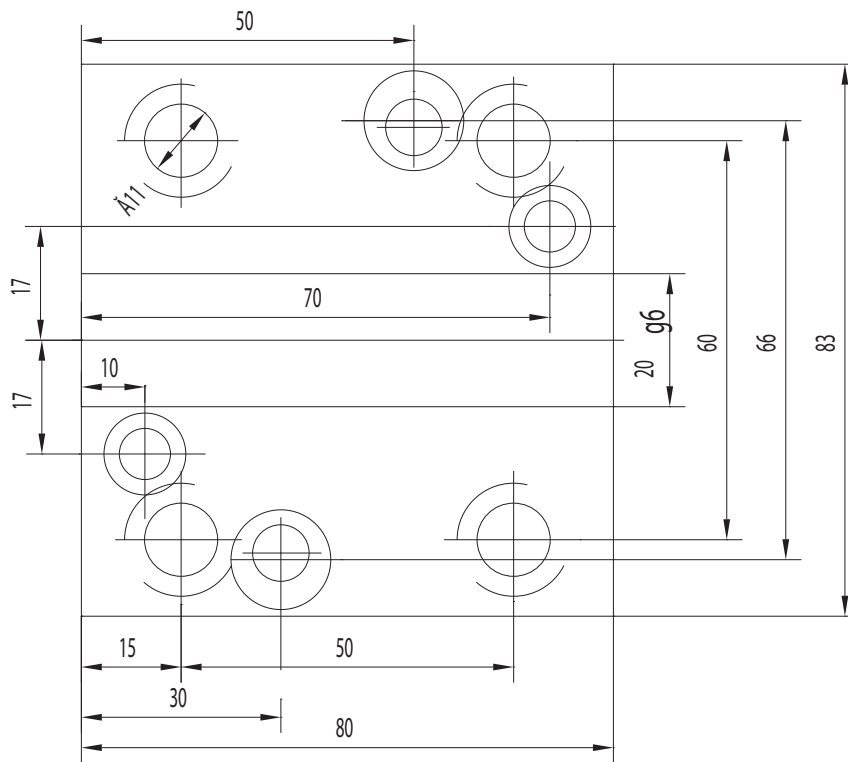

PORTAUTENSILE RADIALE - RADIAL TOOLHOLDERS

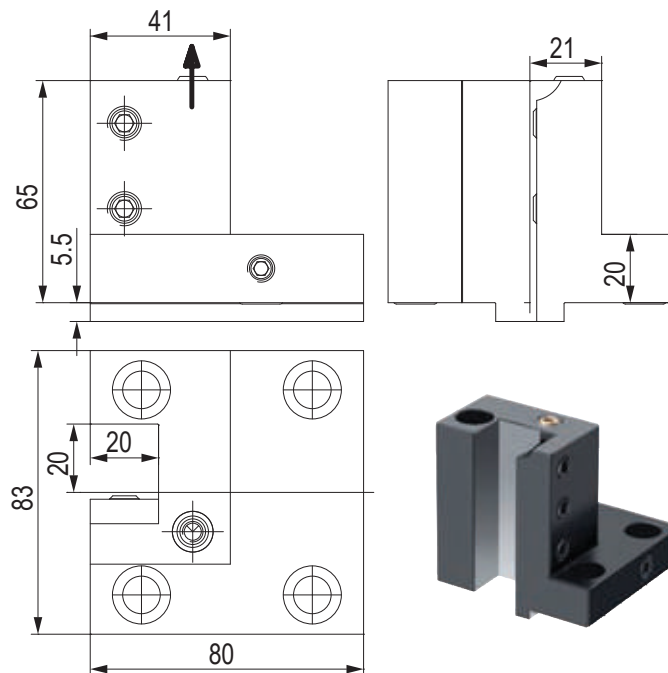

CODE N.	CLAMPING SCREW	COOLANT NOZZLE	O RING
W1431	811-102038	833-001110	823-101015

PORTAUTENSILE RADIALE - RADIAL TOOLHOLDERS

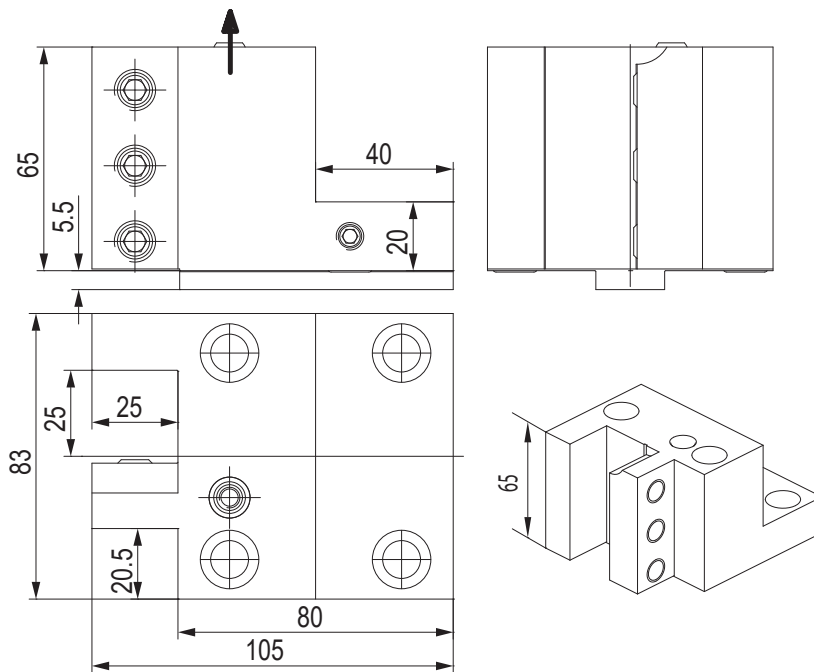

CODE N.	CLAMPING SCREW	COOLANT NOZZLE	O RING
Z2413	811-102044	833-001110	823-101015

PORTAUTENSILE RADIALE - RADIAL TOOLHOLDERS

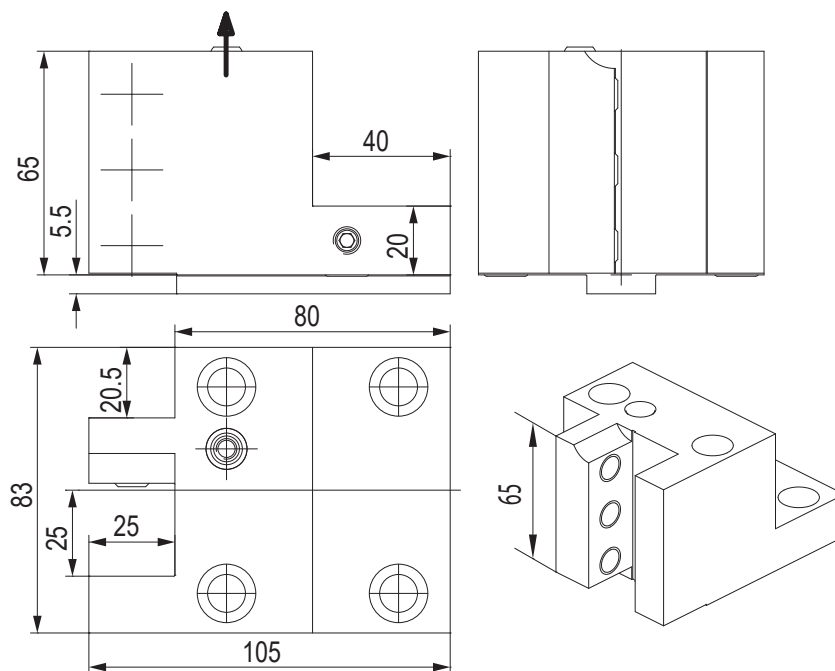

CODE N.	CLAMPING SCREW	COOLANT NOZZLE	O RING
Z2414	811-102044	833-001110	823-101015

PORTAUTENSILE RADIALE - RADIAL TOOLHOLDERS

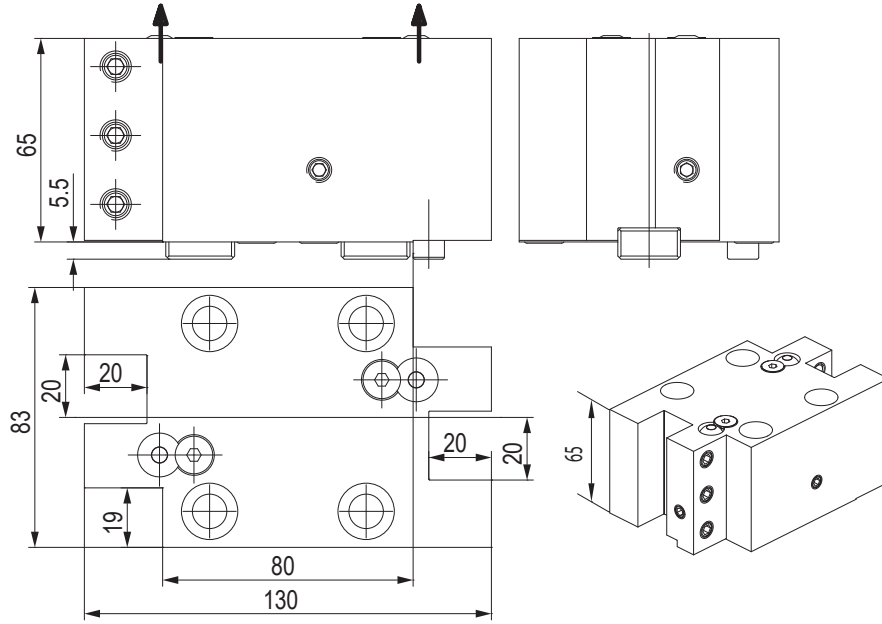

CODE N.	CLAMPING SCREW	KEY	SCREW FOR KEY	COOLANT BALL	SCREW FOR BALL	STOP SCREW	O RING
123-12063	811-102038	814-203270	811-101027	833-001470	811-108018	811-101026	823-101015

PORTAUTENSILE RADIALE - RADIAL TOOLHOLDERS

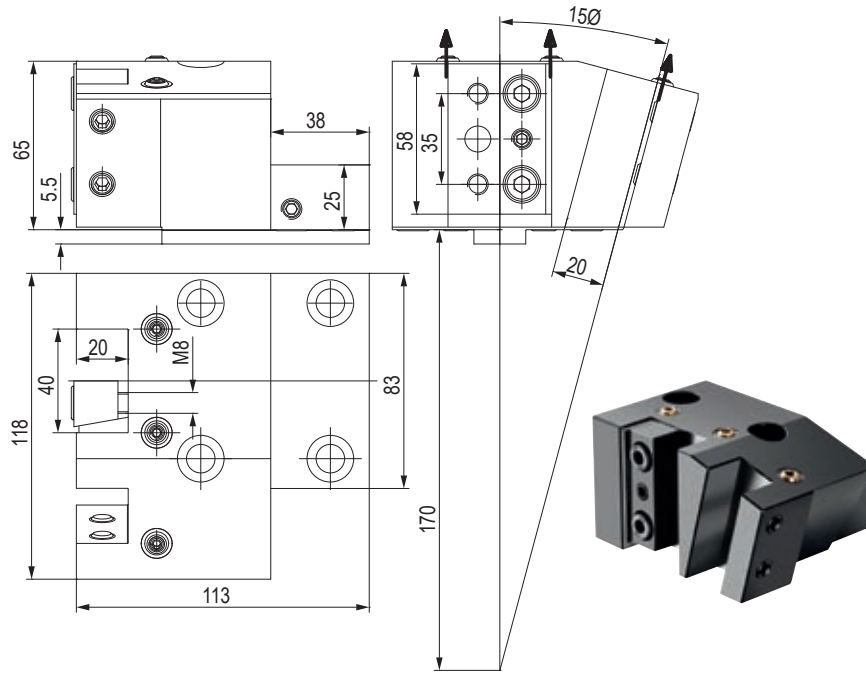

CODE N.	CLAMPING PLATE	CLAMPING SCREW	COOLANT NOZZLE	O RING1 (D9X2)	O RING2 (D6X2)
R1452	832-007160	811-102037	833-001110	823-101015	823-101082

PORTALAMA - CUT-OFF HOLDERS

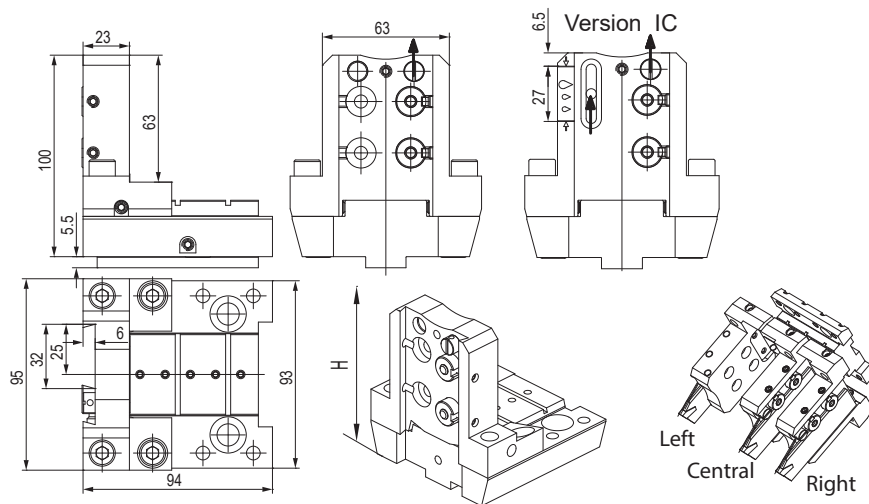

CODE N.	INTERNAL COOLANT	COOLANT NOZZLE	O RING FOR COOLANT NOZZLE	O RING FOR BODY	O RING FOR COOLANT INTAKE	O RING FOR INT. COOLANT
121-22076	NO	833-001490	823-101058	823-101061	823-101015	-
121-22076-IC	YES	833-001490	823-101058	823-101061	823-101015	823-201140

CODE N.	SHIM PLATE	SCREW FOR PLATE	CLAMPING PIN	SPRING	CLAMPING SCREW	SCREW
121-22076	832-014448	811-108037	832-014450	824-300012	811-101028	811-104013
121-22076-IC	832-014448	811-108037	832-014450	824-300012	811-101028	811-104013

PORTAUTENSILE COMBINATO PER BARENI E PUNTE A INSERTI COMBI TOOLHOLDER FOR BORING BAR AND INSERT DRILL

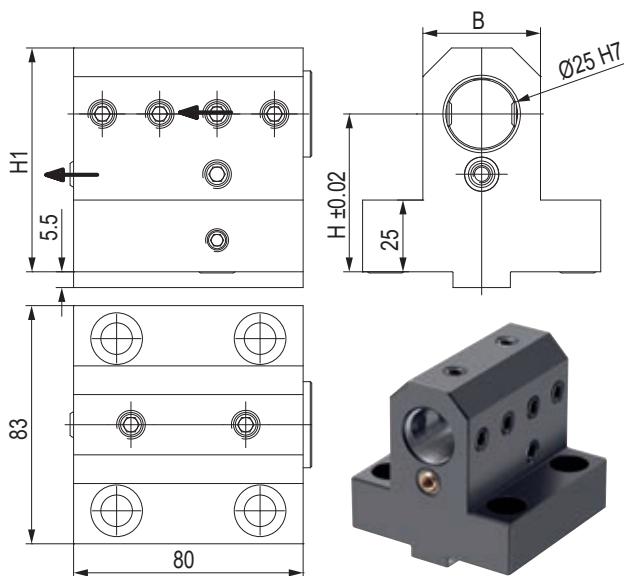

CODE N.	H	H1	B	CLAMPING SCREW1 (M10X10)	CLAMPING SCREW2 (M10X12)	COOLANT NOZZLE	SCREW FOR INTERNAL COOLANT	O RING FOR COOLANT INTAKE	PLUG	O RING FOR PLUG
W1417 D25	55	78	41	811-102035	-	833-001110	811-102038	823-101015	823-301150	823-201140
W4437 D25	75	98	41	811-102035	-	833-001110	811-102038	823-101015	823-301150	823-201140
G1417 D25	85	106.5	50	811-102035	811-102036	833-001110	811-102038	823-101015	823-301150	823-201140

PORTAUTENSILE DOPPIO PER BARENI DOUBLE TOOLHOLDER FOR BORING BAR

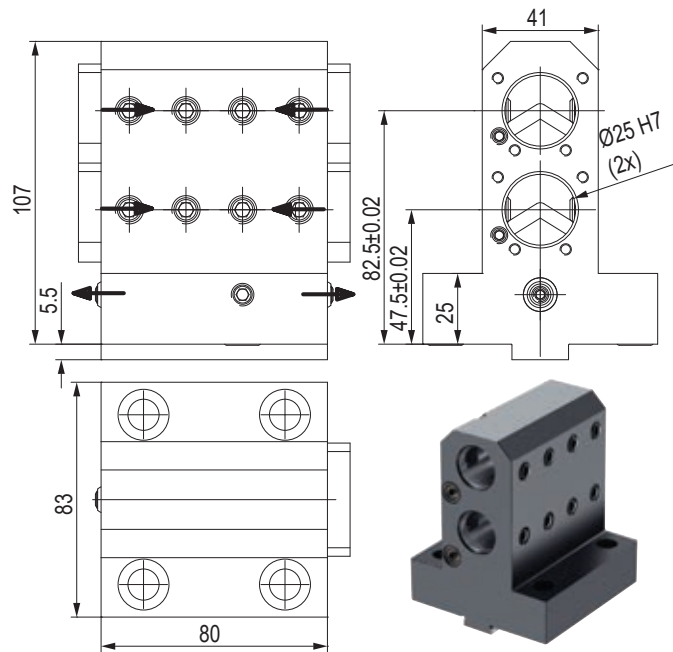

CODE N.	CLAMPING SCREW	COOLANT NOZZLE	O RING FOR COOLANT INTAKE	COVER	SCREW FOR COVER
R8418	811-102035	833-001110	823-101015	832-003295	811-101010

PORTAUTENSILE TRIPLO PER BARENI TREBLE TOOLHOLDER FOR BORING BAR

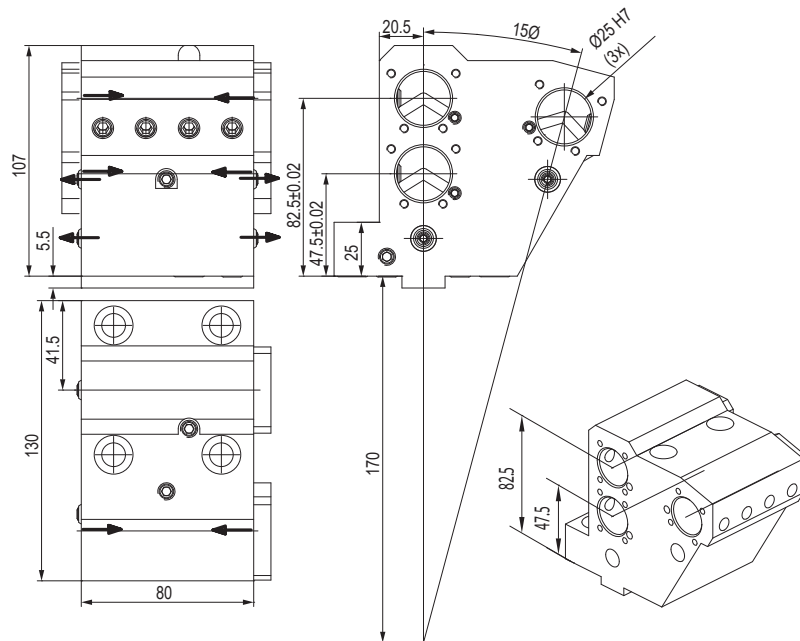

CODE N.	CLAMPING SCREW	COOLANT NOZZLE	O RING FOR COOLANT INTAKE1 (D10X2.5)	O RING FOR COOLANT INTAKE2 (D6X2)	COVER	SCREW FOR COVER
R8453	811-102035	833-001110	823-101004	823-101082	832-003295	811-101010

PORTAUTENSILE COMBINATO PER BARENI E PUNTE A INSERTI COMBI TOOLHOLDER FOR BORING BAR AND INSERTDRILL

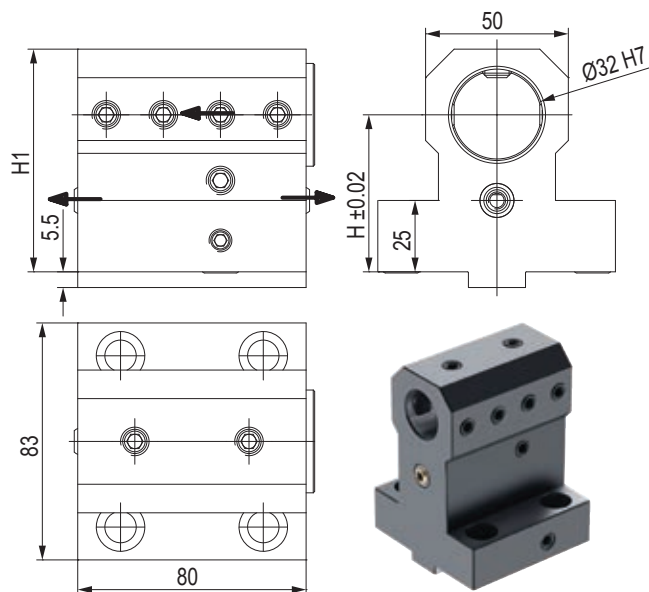

CODE N.	H	H1	CLAMPING SCREW	COOLANT NOZZLE	SCREW FOR INTERNAL COOLANT	O RING FOR COOLANT INTAKE	PLUG	O RING FOR PLUG	STOP PLATE	SCREW FOR PLATE
W1417 D32	55	78	811-102035	833-001110	811-102038	823-101015	823-301140	823-201080	-	-
Z2417 D32	70	96.5	811-102035	833-001110	811-102038	823-101015	823-301140	823-201080	-	-
Z7417 D32	80	106.5	811-102035	833-001110	811-102038	823-101015	823-301140	823-201080	832-003349	811-108029

PORTAUTENSILE CON USCITA POLIGONALE POLIGONAL TOOLHOLDERS

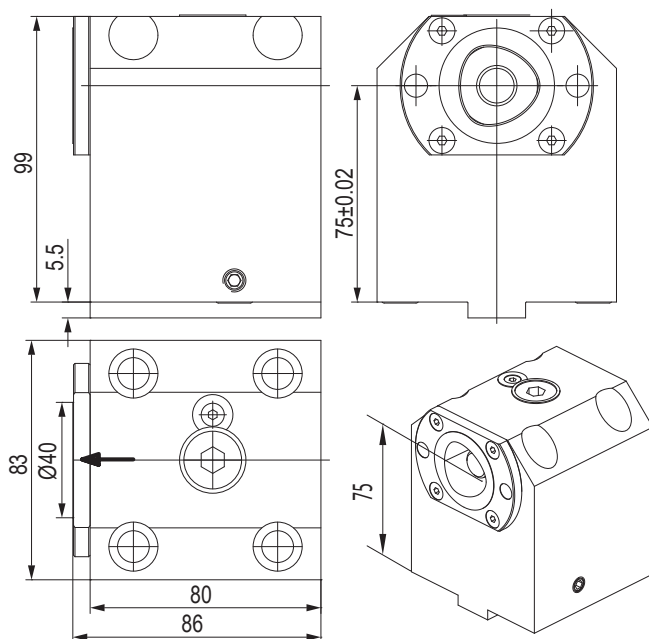

CODE N.	CAPTO	CLAMPING UNIT	O RING FOR COOLANT INTAKE
121-22098	C40	CXC40-10	823-101015

PORTAUTENSILE CON USCITA POLIGONALE POLIGONAL TOOLHOLDERS

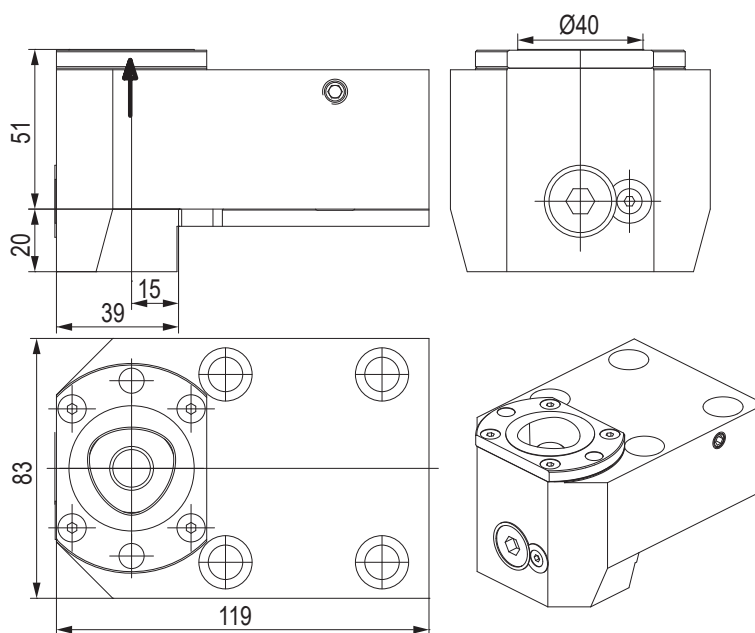

CODE N.	CAPTO	CLAMPING UNIT	O RING FOR COOLANT INTAKE
---------	-------	---------------	---------------------------

121-22099	C40	CXC40-10	823-101015
-----------	-----	----------	------------



PORTAUTENSILE MOTORIZZATO ASSIALE STRAIGHT DRILLING AND MILLING HEAD

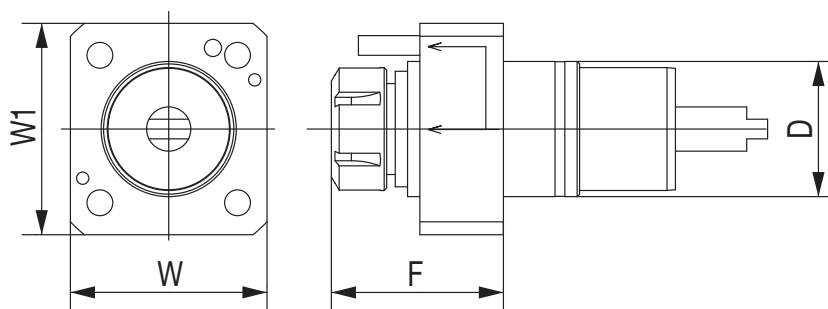

CODE N.	D	ER	INTERNAL COOLING	F	W	W1	TORQUE (Nm)	NMAX (Rpm)	RATIO	P (Bar)
124-05507	55	ER25	no	78	80	86	50	6000	1:1	-
124-05508	55	ER25	yes	78	80	86	50	6000	1:1	20

PORTAUTENSILE MOTORIZZATO RADIALE ANGULAR DRILLING AND MILLING HEAD

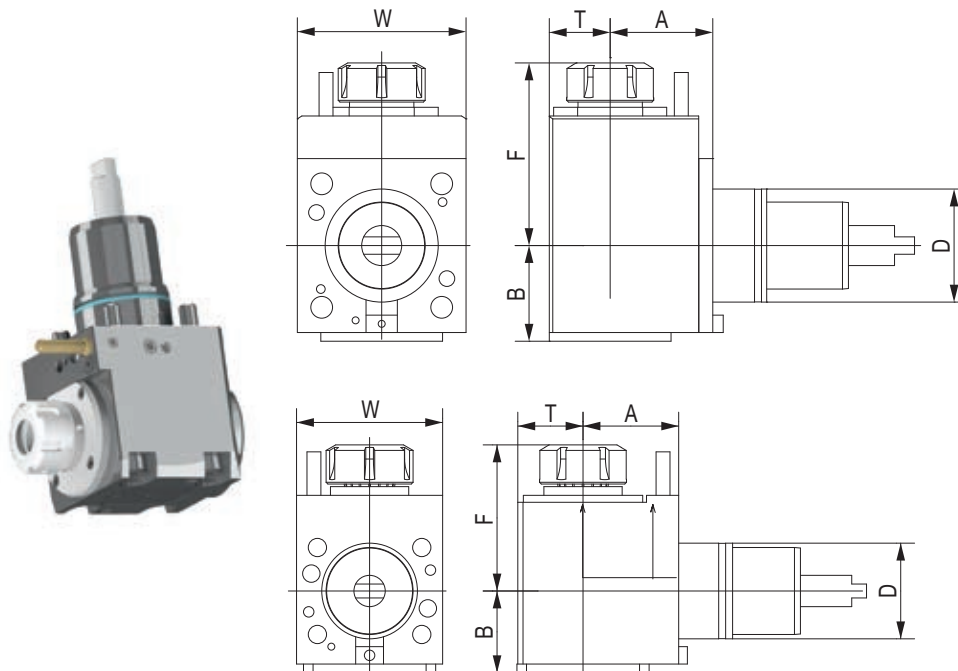

CODE N.	D	ER	INTERNAL COOLING	DIRECTION	A	B	F	T	W	TORQUE (Nm)	NMAX (Rpm)	RATIO	P (Bar)
124-05509	55	ER25	no	right/left	55	50,3	74,8	35	84	28	6000	1:1	-
124-05510	55	ER25	yes	right/left	55	50,3	74,8	35	84	28	6000	1:1	20

TAPPO DI PROTEZIONE - PROTECTION COVER

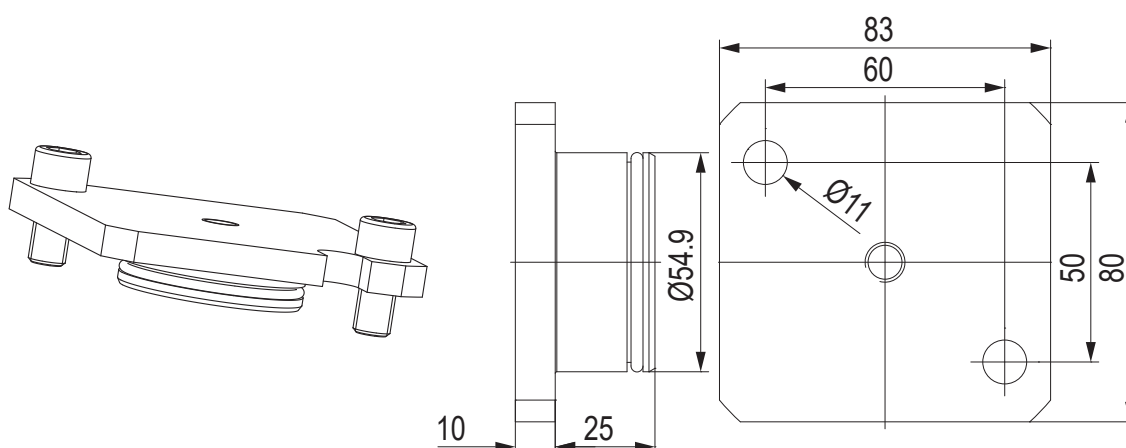

CODE N.	O RING
137-00249	823-101064



BUSSOLA PER PORTABARENI BORING BAR SLEEVE FOR TOOLHOLDER

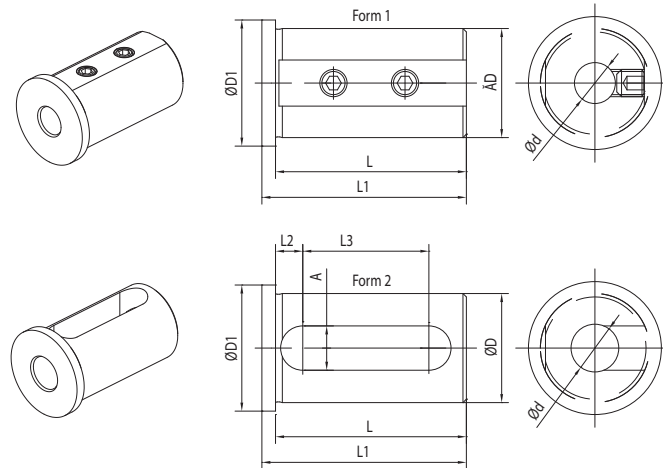

CODE N.	D	d	FORM	L	L1	L2	L3	A	D1
165-62551	25	8	1	46	50	-	-	-	30
165-62552	25	10	1	46	50	-	-	-	30
165-62553	25	12	1	46	50	-	-	-	30
165-62555	25	16	2	46	50	8	27	13	30
165-63352	32	8	1	56	60	-	-	-	37
165-63353	32	10	1	56	60	-	-	-	37
165-63354	32	12	1	56	60	-	-	-	37
165-63356	32	16	2	56	60	8	37	13	37
165-63358	32	20	2	56	60	8	37	13	37
165-63359	32	25	2	56	60	8	37	13	37

BUSSOLA PER PORTABARENI BORING BAR SLEEVE FOR TOOLHOLDER

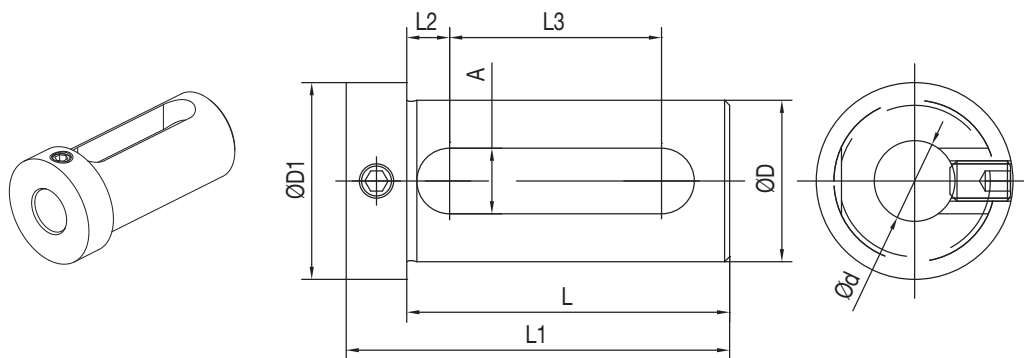

CODE N.	D	d	L	L1	L2	L3	A	D1
165-62545	25	12	54	66	8,5	32	13	32
165-62547	25	16	54	66	8,5	32	13	32
165-62549	25	20	54	66	8,5	32	13	32
165-63347	32	16	64	76	8,5	42	13	39
165-63349	32	20	64	76	8,5	42	13	39
165-63350	32	25	64	76	8,5	42	13	39

BUSSOLA PER PORTABARENI BORING BAR SLEEVE FOR TOOLHOLDER

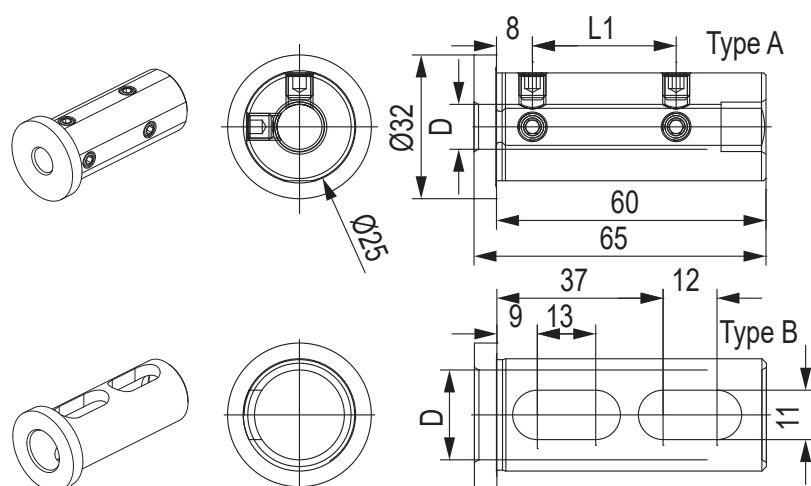

CODE N.	Ø	D	L1	TYPE	SCREW
115-62573	25	6	22	A	811-102011
115-62538	25	8	27	A	811-102018
115-62539	25	10	32	A	811-102017
115-62540	25	12	32	A	811-102017
115-62541	25	16	-	B	-



**NAKAMURA
TOME (BMT55)**

AS-200 / NTM 3 / NTY3-250
SC-150M / SC-200MY / SC-250M
SuperNTJ / TMC-20 II M/M/L
TW-10 / TW-20 / WT-20 II M/MY
WT150/200 / WT-250 / WTS-150
WTW-150/160 / WT200 II (M,MY)
WY-250

CMZ

CMZ TX52/66 / SUPER NTJ
NTM3 / SC150/250
TX52 Y3-Y2 QUATTRO-Y2 TW IN
TX66 Y3-Y2 QUATTRO-Y2 TW IN
TTL 52 / TTL 66
TA15-20-25-30M/Y/MS/MY/YS 15ST

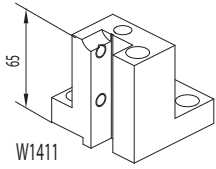

Face and O.D. cutting holder

W1411

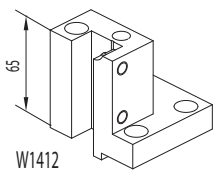

Face and O.D. cutting holder

W1412

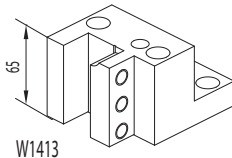

Face and O.D. cutting holder

W1413

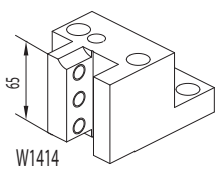

Face and O.D. cutting holder

W1414

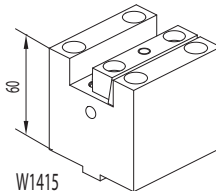

Face and I.D. cutting holder

W1415

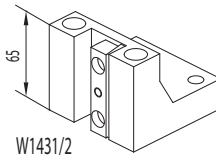

Face and O.D. cutting holder

W1431/2

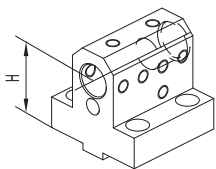

Combi toolholder for boring bar and insertdrill

Ø25 mm

W1417 D25 (H=55 mm)
W4437 D25 (H=75 mm)

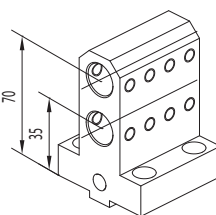

Double toolholder for boring bar

Ø25 mm

W1418 D25

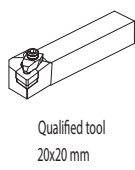

Qualified tool
20x20 mm

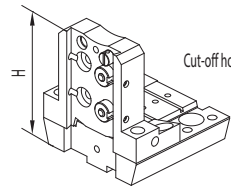

121-22076 (h=32 mm H=100 mm)

ACCESSORIES

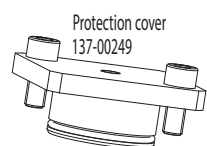

Protection cover
137-00249

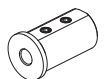

Boring bar sleeve
165-62551 (Ø8)
165-62552 (Ø10)
165-62553 (Ø12)

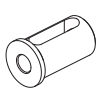

Boring bar sleeve
165-62555 (Ø16)

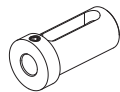

Boring bar sleeve
165-62545 (Ø12)
165-62547 (Ø16)
165-62549 (Ø20)

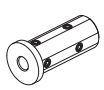

Boring bar sleeve
115-62573 (Ø6)
115-62538 (Ø8)
115-62539 (Ø10)
115-62540 (Ø12)

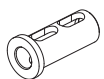

Boring bar sleeve
115-62541 (Ø16)



124-05507
124-05508 I.Coolant

124-05509
124-05510 I.Coolant

FAST-IN

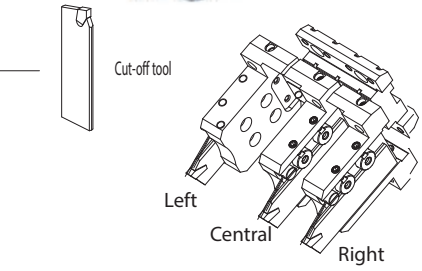
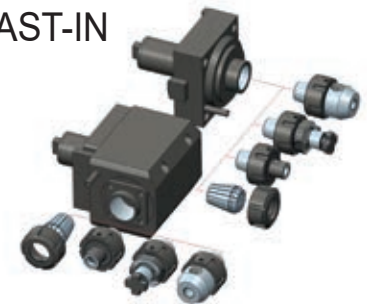

CONNECTION

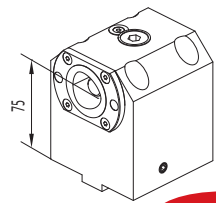
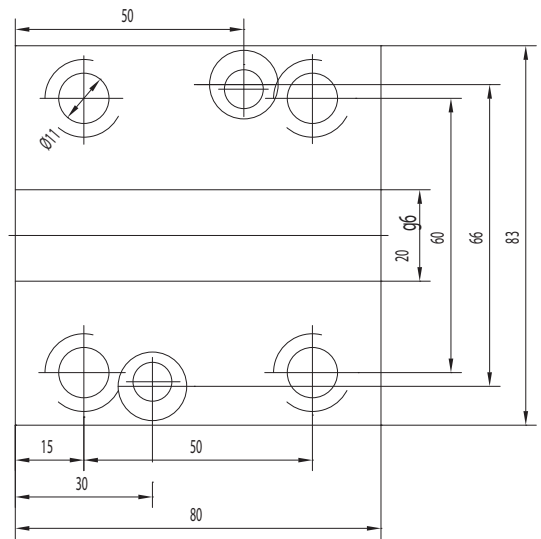

Boring bar holder
Polygonal C40

121-22098

NEWS

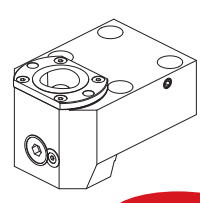

Face and O.D. cutting holder
Polygonal C40

121-22099

NEWS

CONNECTION

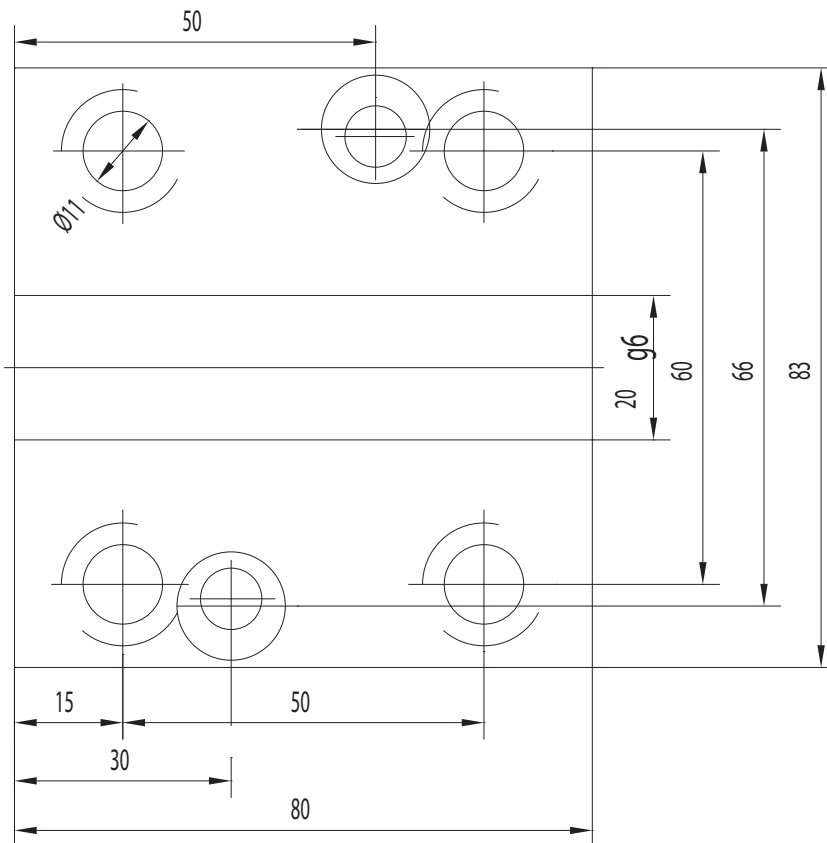

PORTAUTENSILE RADIALE - RADIAL TOOLHOLDERS

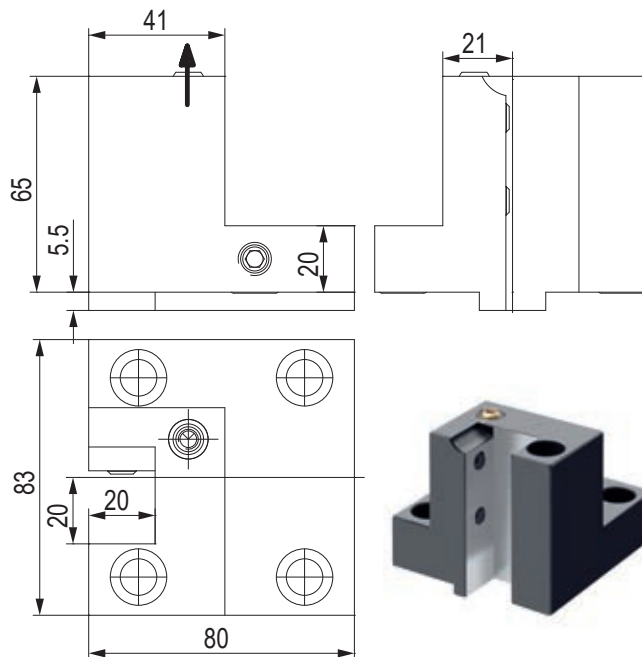

CODE N.	CLAMPING SCREW	COOLANT NOZZLE	O RING
W1411	811-102038	833-001110	823-101004

PORTAUTENSILE RADIALE - RADIAL TOOLHOLDERS

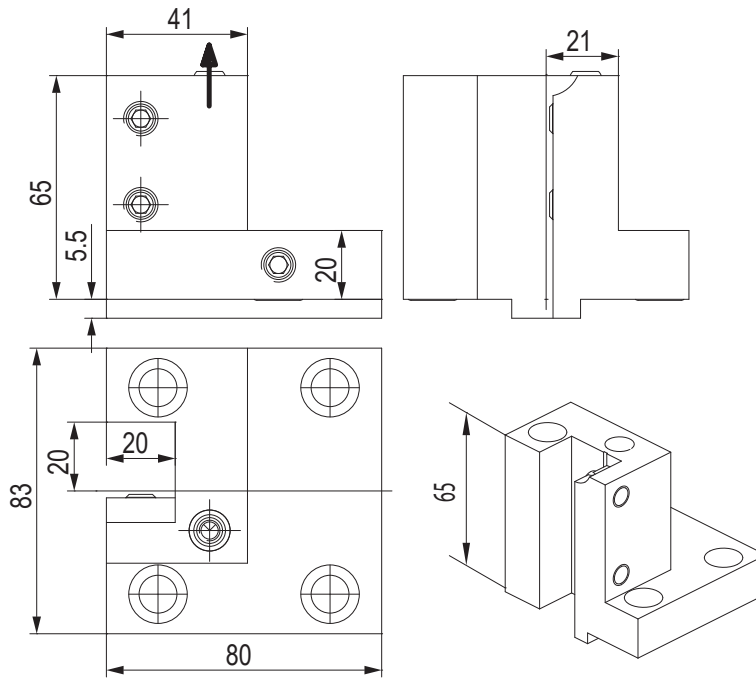

CODE N.	CLAMPING SCREW	COOLANT NOZZLE	O RING
W1412	811-102038	833-001110	823-101004

PORTAUTENSILE RADIALE - RADIAL TOOLHOLDERS

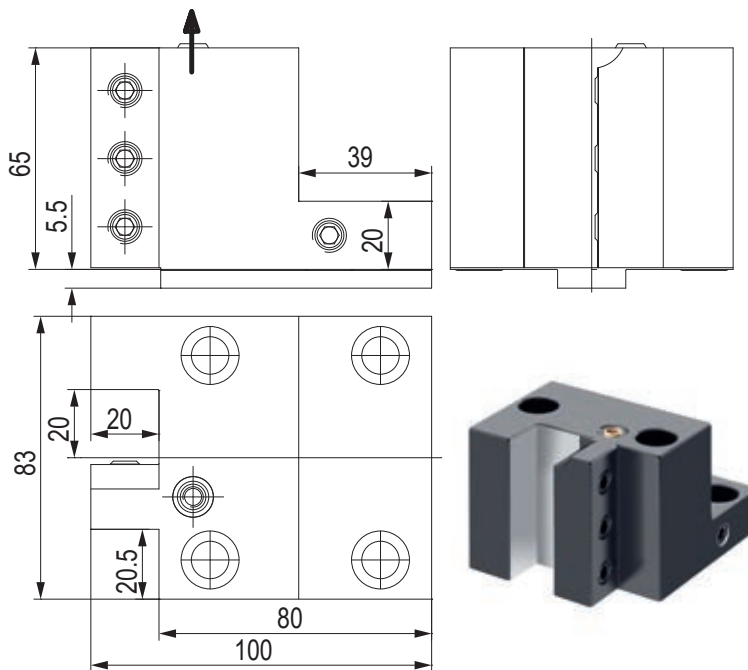

CODE N.	CLAMPING SCREW	COOLANT NOZZLE	O RING
W1413	811-102038	833-001110	823-101004

PORTAUTENSILE RADIALE - RADIAL TOOLHOLDERS

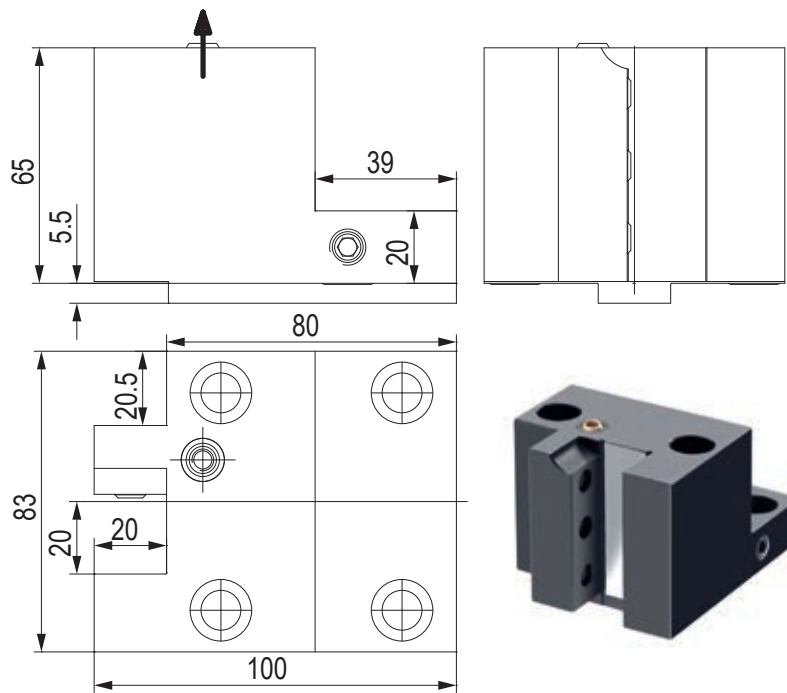

CODE N.	CLAMPING SCREW	COOLANT NOZZLE	O RING
W1414	811-102038	833-001110	823-101004

PORTAUTENSILE RADIALE - RADIAL TOOLHOLDERS

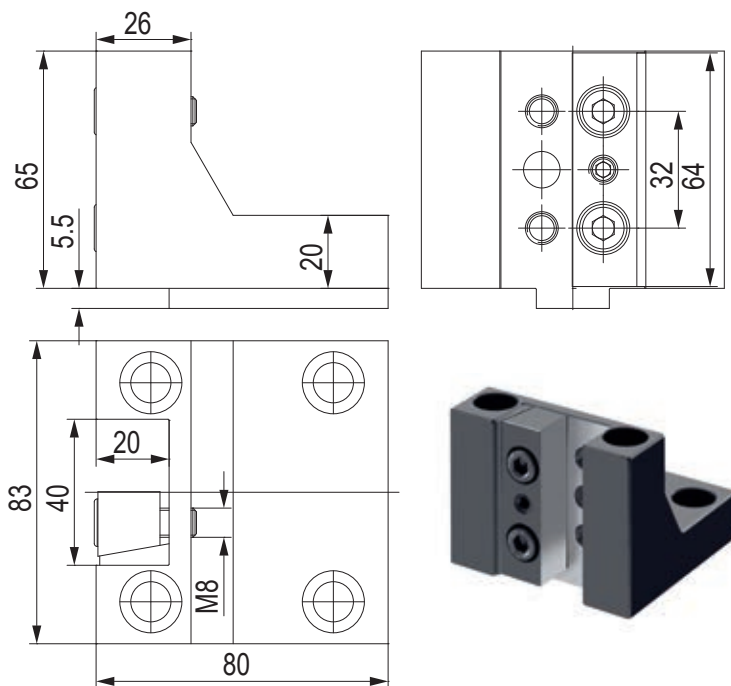

CODE N.	CLAMPING PLATE
W1431/2	832-007380

PORTAUTENSILE ASSIALE - AXIAL TOOLHOLDERS

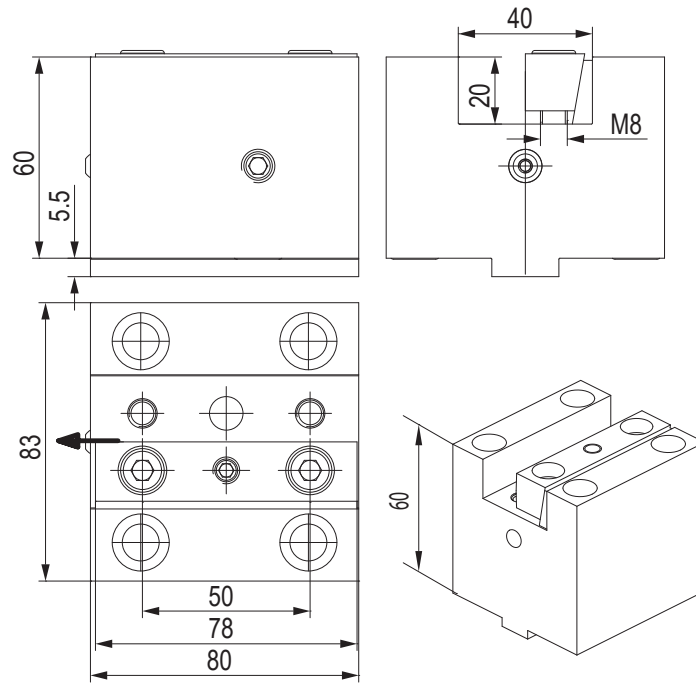

CODE N.	CLAMPING PLATE	COOLANT NOZZLE	O RING
W1415	832-007200	833-001100	823-101004

PORTALAMA - CUT-OFF HOLDERS

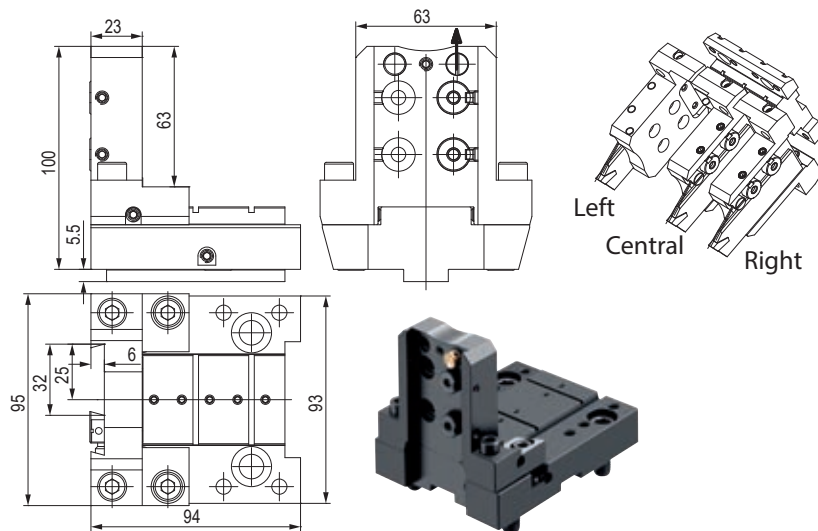





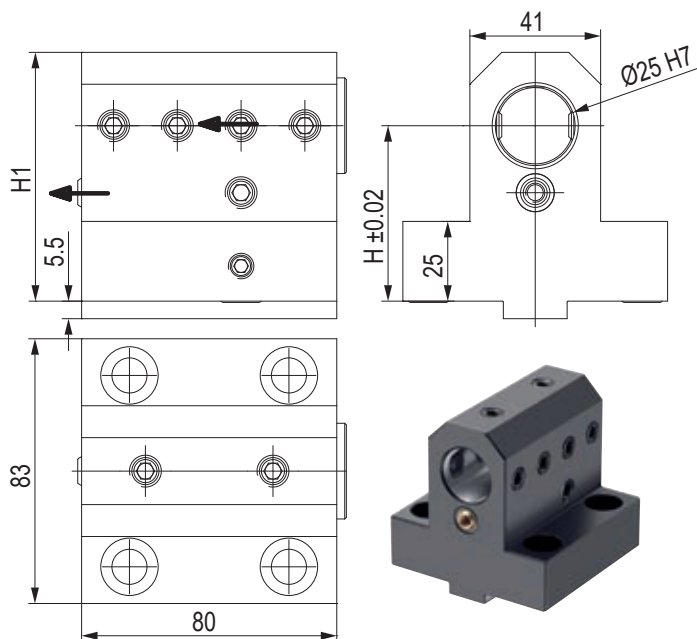

CODE N.	COOLANT NOZZLE	O RING FOR COOLANT NOZZLE	O RING FOR BODY	O RING FOR COOLANT INTAKE
121-22076	833-001490	823-101058	823-101061	823-101015

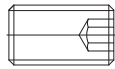
CODE N.	SHIM PLATE	SCREW FOR PLATE	CLAMPING PIN	SPRING	CLAMPING SCREW	SCREW
121-22076	832-014448	811-108037	832-014450	824-300012	811-101028	811-104013

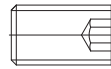

PORTAUTENSILE COMBINATO PER BARENI E PUNTE A INSERTI COMBI TOOLHOLDER FOR BORING BAR AND INSERTDRILL

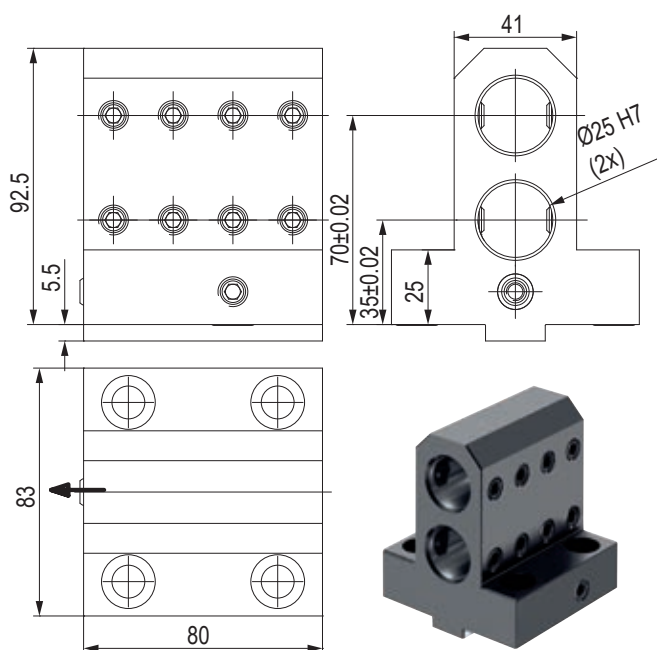

CODE N.	H	H1	CLAMPING SCREW	COOLANT NOZZLE	SCREW FOR INTERNAL COOLANT	O RING FOR COOLANT INTAKE	PLUG	O RING FOR PLUG
W1417 D25	55	78						
W4437 D25	75	98	811-102035	833-001110	811-102038	823-101015	823-301150	823-201140
			811-102035	833-001110	811-102038	823-101015	823-301150	823-201140

PORTAUTENSILE DOPPIO PER BARENI DOUBLE TOOLHOLDER FOR BORING BAR

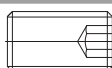

CODE N.	CLAMPING SCREW	COOLANT NOZZLE	O RING FOR COOLANT INTAKE
W1418 D25			
W1418 D25	811-102035	833-001110	823-101004

PORTAUTENSILE CON USCITA POLIGONALE POLIGONAL TOOLHOLDERS

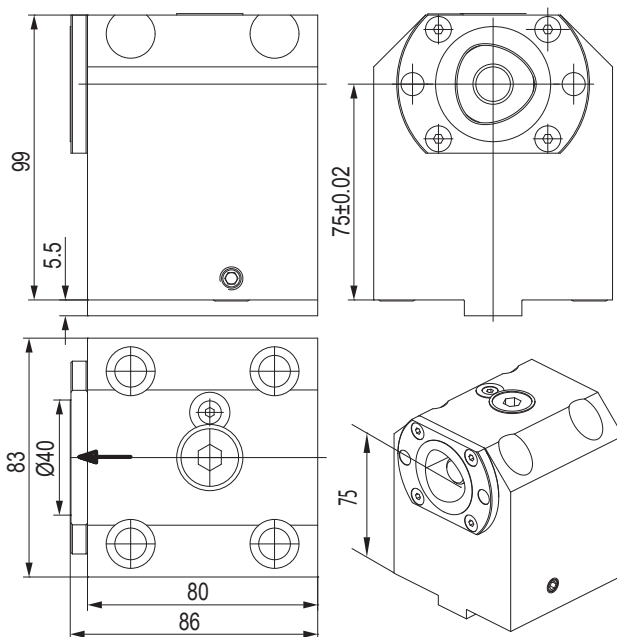

CODE N.	CAPTO	CLAMPING UNIT	O RING FOR COOLANT INTAKE
---------	-------	---------------	---------------------------

121-22098	C40	CXC40-10	823-101015
-----------	-----	----------	------------



PORTAUTENSILE CON USCITA POLIGONALE POLIGONAL TOOLHOLDERS

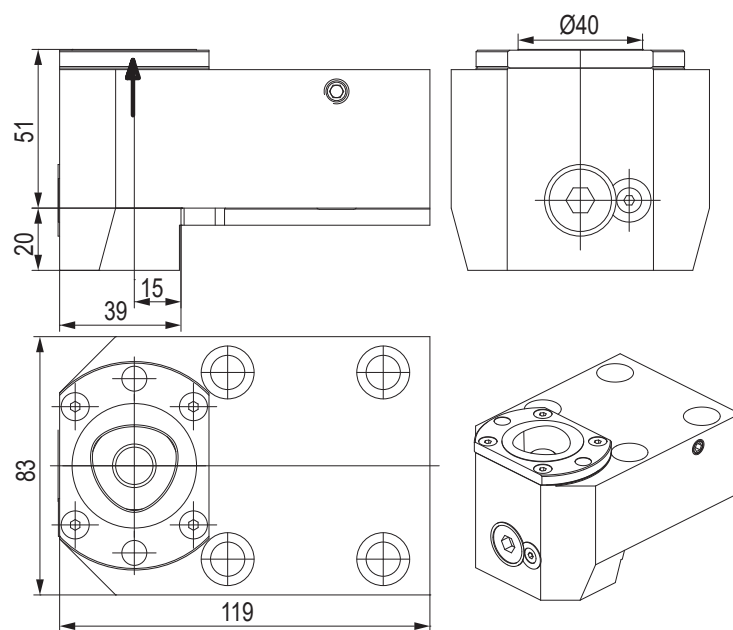

CODE N.	CAPTO	CLAMPING UNIT	O RING FOR COOLANT INTAKE
---------	-------	---------------	---------------------------

121-22099	C40	CXC40-10	823-101015
-----------	-----	----------	------------



PORTAUTENSILE MOTORIZZATO ASSIALE STRAIGHT DRILLING AND MILLING HEAD

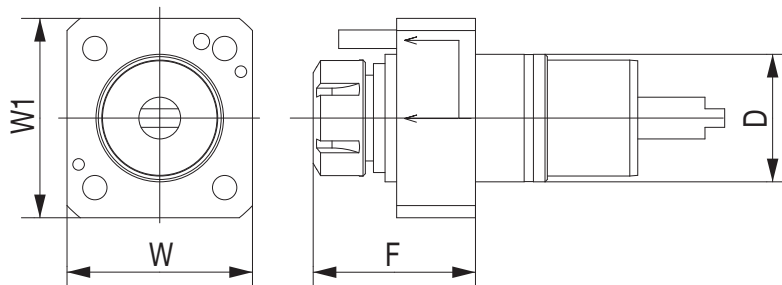

CODE N.	D	ER	INTERNAL COOLING	F	W	W1	TORQUE (Nm)	NMAX (Rpm)	RATIO	P (Bar)
124-05507	55	ER25	no	78	80	86	50	6000	1:1	-
124-05508	55	ER25	yes	78	80	86	50	6000	1:1	20

PORTAUTENSILE MOTORIZZATO RADIALE ANGULAR DRILLING AND MILLING HEAD

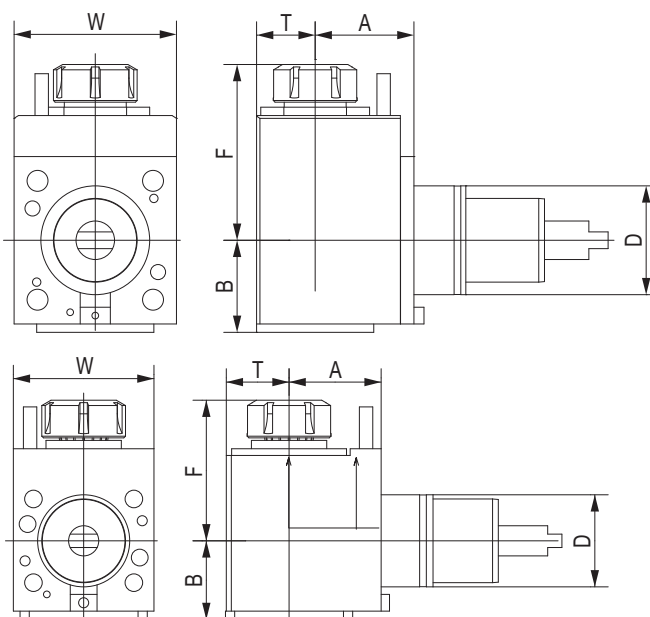
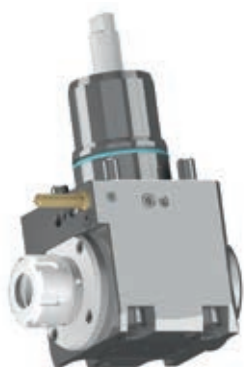

CODE N.	D	ER	INTERNAL COOLING	DIRECTION	A	B	F	T	W	TORQUE (Nm)	NMAX (Rpm)	RATIO	P (Bar)
124-05509	55	ER25	no	right/left	55	50,3	74,8	35	84	28	6000	1:1	-
124-05510	55	ER25	yes	right/left	55	50,3	74,8	35	84	28	6000	1:1	20

TAPPO DI PROTEZIONE - PROTECTION COVER

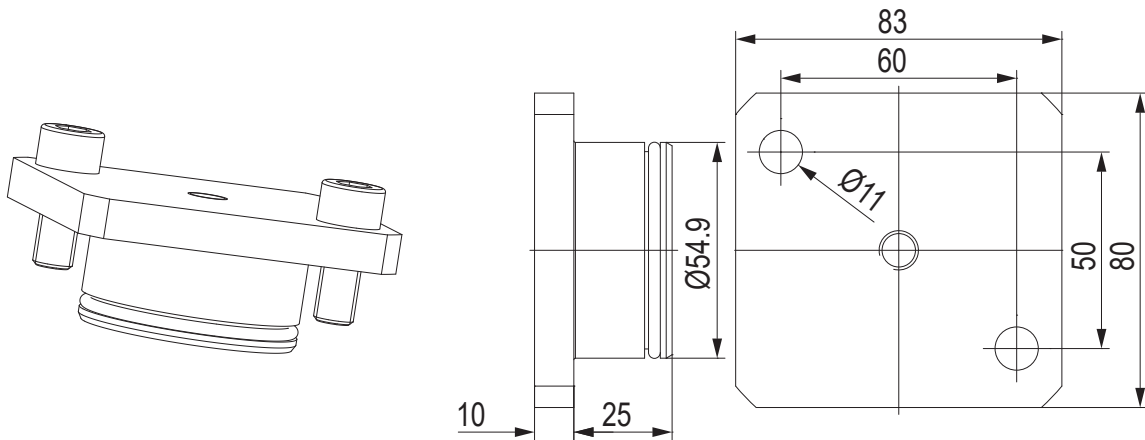

CODE N.

O RING



137-00249

823-101064

BUSSOLA PER PORTABARENI BORING BAR SLEEVE FOR TOOLHOLDER

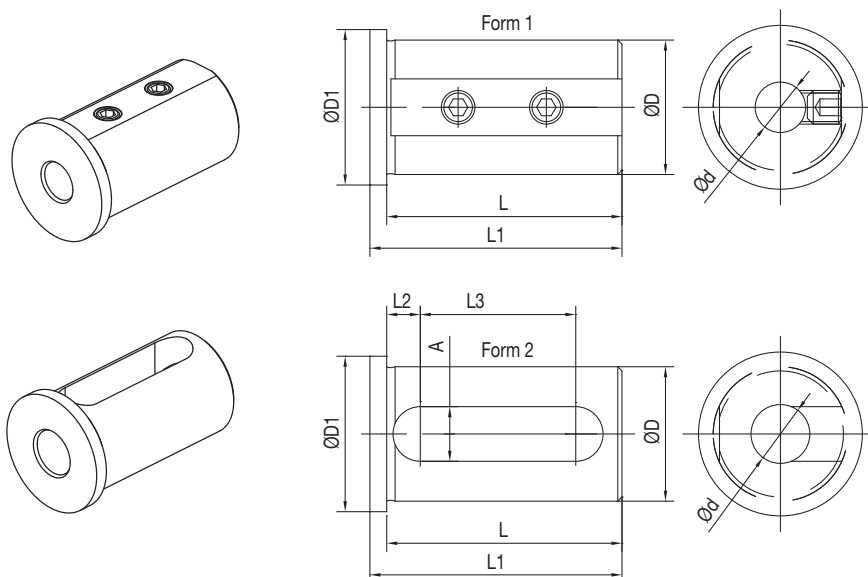

CODE N.	D	d	FORM	L	L1	L2	L3	A	D1
165-62551	25	8	1	46	50	-	-	-	30
165-62552	25	10	1	46	50	-	-	-	30
165-62553	25	12	1	46	50	-	-	-	30
165-62555	25	16	2	46	50	8	27	13	30

BUSSOLA PER PORTABARENI BORING BAR SLEEVE FOR TOOLHOLDER

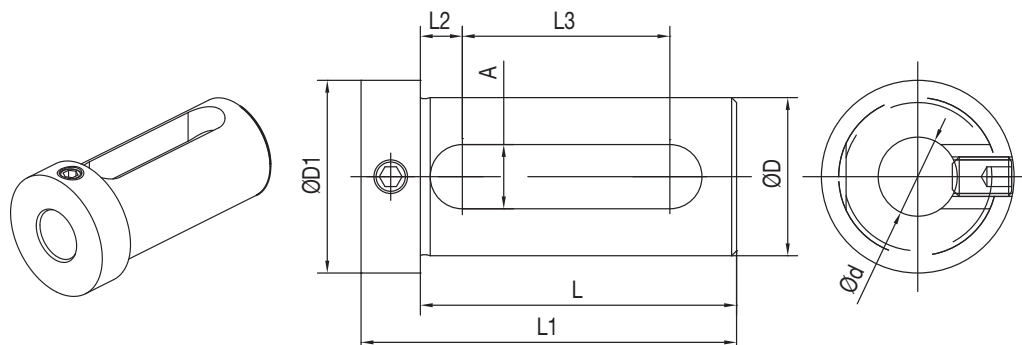

CODE N.	D	d	L	L1	L2	L3	A	D1
165-62545	25	12	54	66	8,5	32	13	32
165-62547	25	16	54	66	8,5	32	13	32
165-62549	25	20	54	66	8,5	32	13	32

BUSSOLA PER PORTABARENI BORING BAR SLEEVE FOR TOOLHOLDER

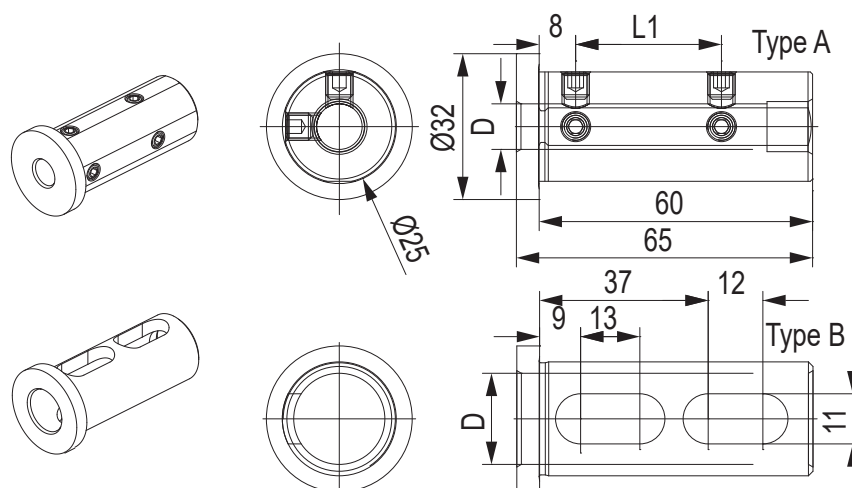

CODE N.	Ø	D	L1	TYPE	SCREW
115-62573	25	6	22	A	811-102011
115-62538	25	8	27	A	811-102018
115-62539	25	10	32	A	811-102017
115-62540	25	12	32	A	811-102017
115-62541	25	16	-	B	-

CONNECTION

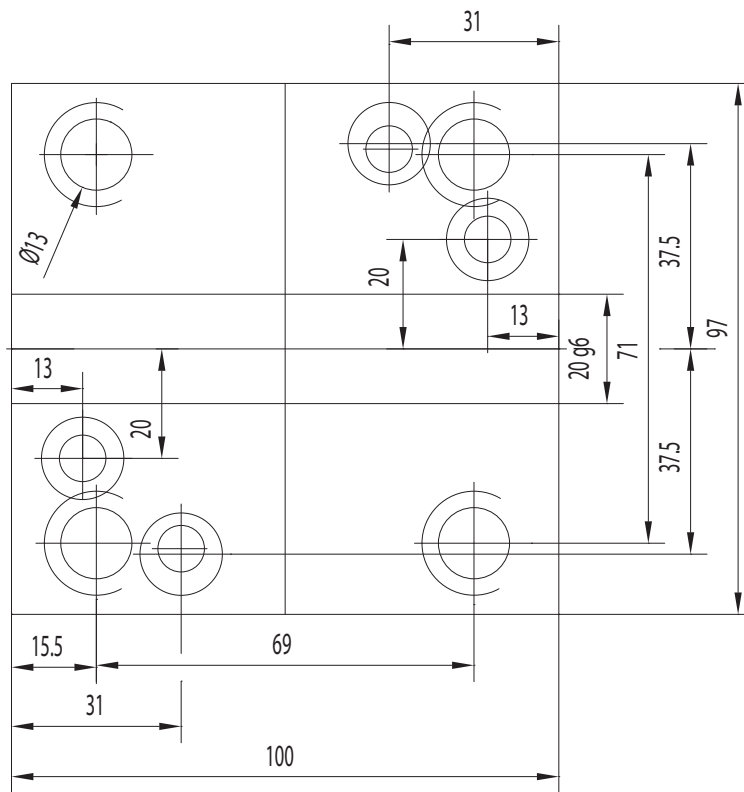

PORTAUTENSILE RADIALE - RADIAL TOOLHOLDERS

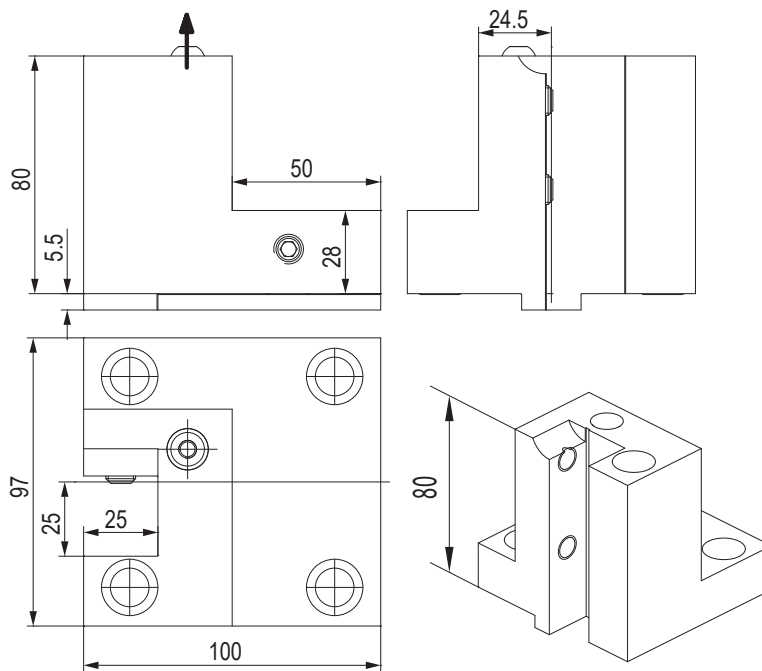

CODE N.	CLAMPING SCREW	COOLANT NOZZLE	O RING
W2411	811-102039	833-001120	823-101004

PORTAUTENSILE RADIALE - RADIAL TOOLHOLDERS

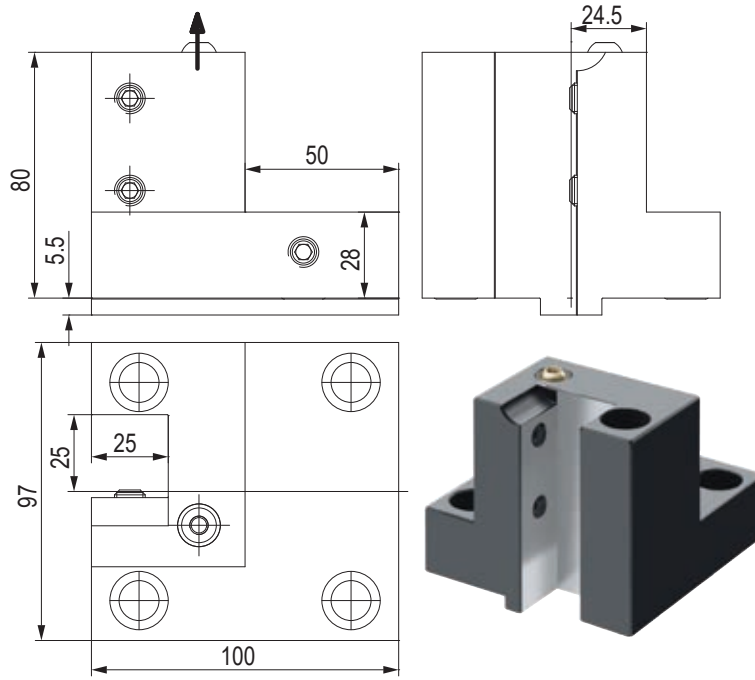

CODE N.	CLAMPING SCREW	COOLANT NOZZLE	O RING
W2412	811-102039	833-001120	823-101004

PORTAUTENSILE RADIALE - RADIAL TOOLHOLDERS

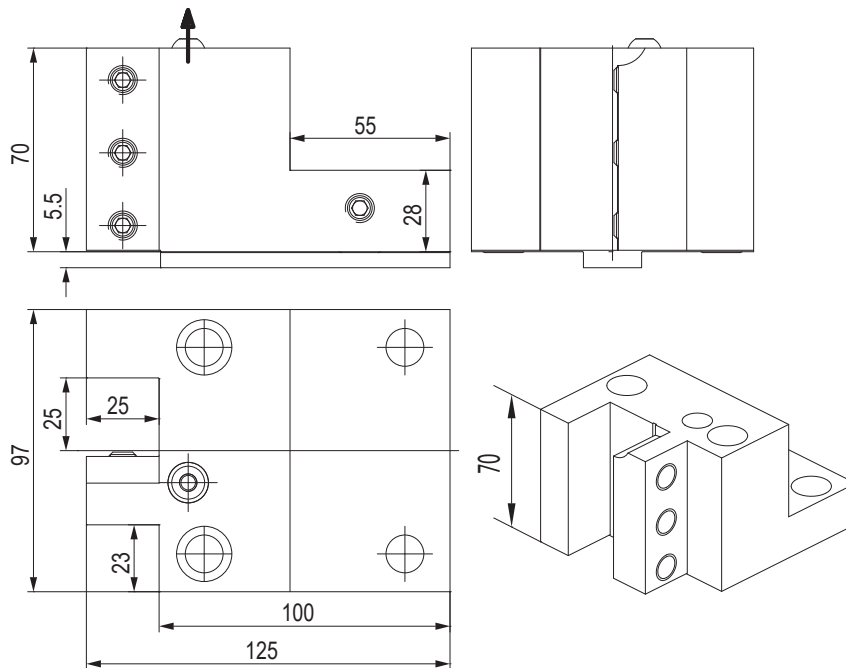

CODE N.	CLAMPING SCREW	COOLANT NOZZLE	O RING
W2413	811-102039	833-001120	823-101004

PORTAUTENSILE RADIALE - RADIAL TOOLHOLDERS

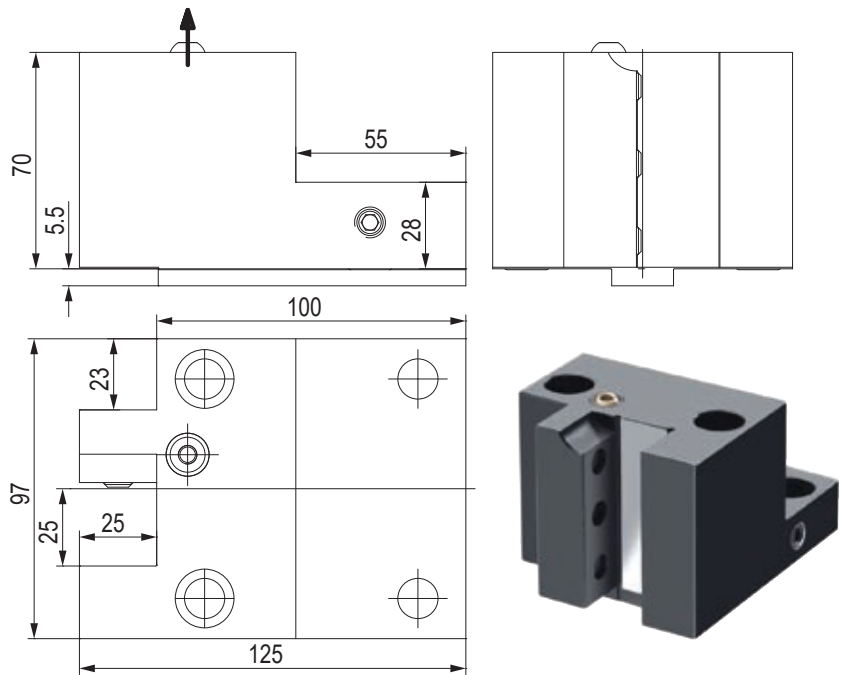

CODE N.	CLAMPING SCREW	COOLANT NOZZLE	O RING
W2414	811-102039	833-001120	823-101004

PORTAUTENSILE RADIALE - RADIAL TOOLHOLDERS

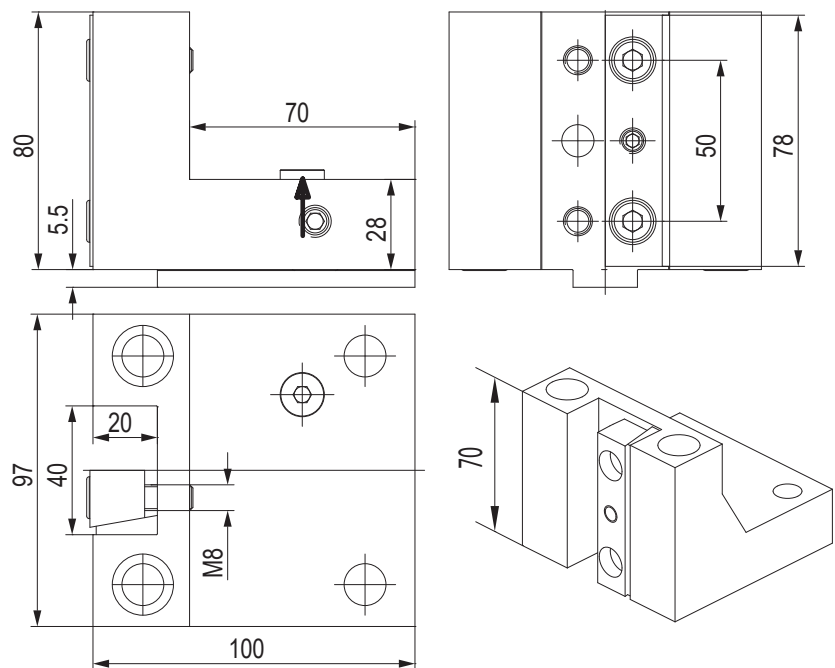

CODE N.	CLAMPING PLATE	O RING	SCREW
W2431	832-007200	823-101004	811-302106

PORTAUTENSILE ASSIALE - AXIAL TOOLHOLDERS

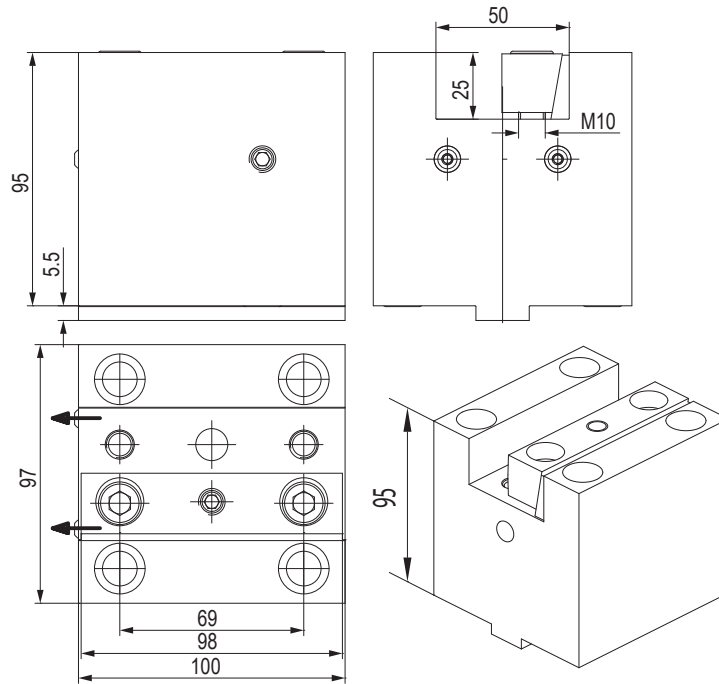

CODE N.	CLAMPING SCREW	COOLANT NOZZLE	O RING
W2415	832-007220	833-001100	823-101004

PORTAUTENSILE COMBINATO PER BARENI E PUNTE A INSERTI COMBI TOOLHOLDER FOR BORING BAR AND INSERTDRILL

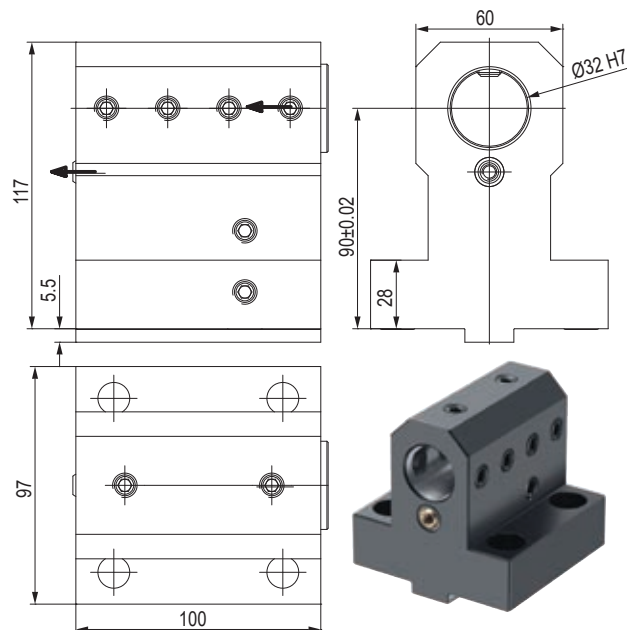

CODE N.	CLAMPING SCREW	COOLANT NOZZLE	SCREW FOR INTERNAL COOLANT	O RING FOR COOLANT INTAKE	PLUG	O RING FOR PLUG
W2417 D32	811-102060	833-001110	811-102038	823-101004	823-301140	823-201080

PORTAUTENSILE DOPPIO PER BARENI DOUBLE TOOLHOLDER FOR BORING BAR

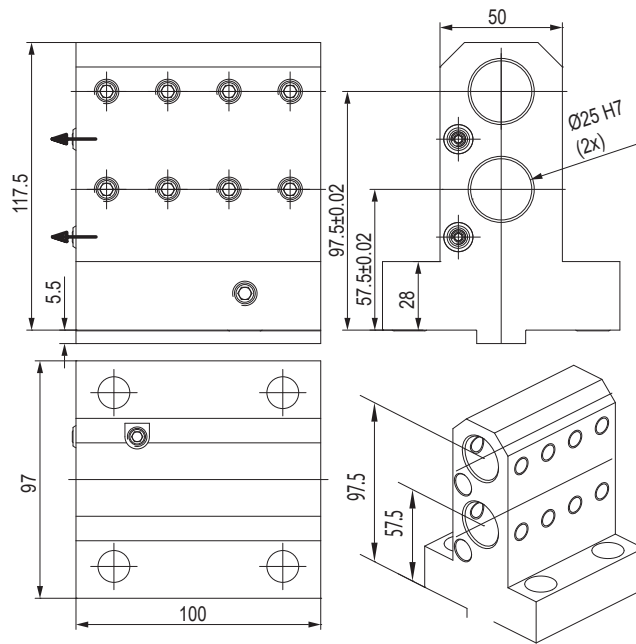

CODE N.	CLAMPING SCREW	COOLANT NOZZLE	O RING FOR COOLANT INTAKE
W2438 D25	811-102036	833-001110	823-101004

PORTAUTENSILE CON USCITA POLIGONALE POLIGONAL TOOLHOLDERS

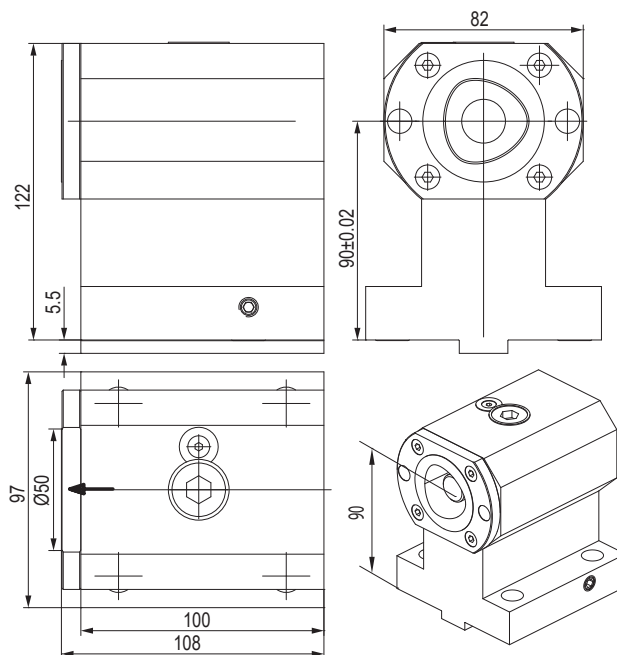

CODE N.	CAPTO	CLAMPING UNIT	O RING FOR COOLANT INTAKE
121-22101	C50	CXC50-10	823-101004

PORTAUTENSILE CON USCITA POLIGONALE POLIGONAL TOOLHOLDERS

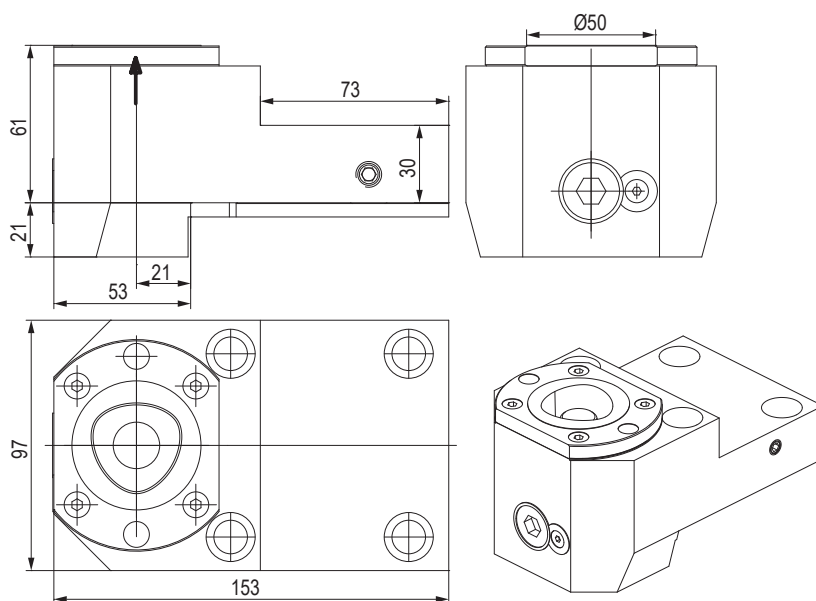

CODE N.	CAPTO	CLAMPING UNIT	O RING FOR COOLANT INTAKE
---------	-------	---------------	---------------------------

121-22102	C50	CXC50-10	823-101004
-----------	-----	----------	------------



PORTAUTENSILE MOTORIZZATO ASSIALE STRAIGHT DRILLING AND MILLING HEAD

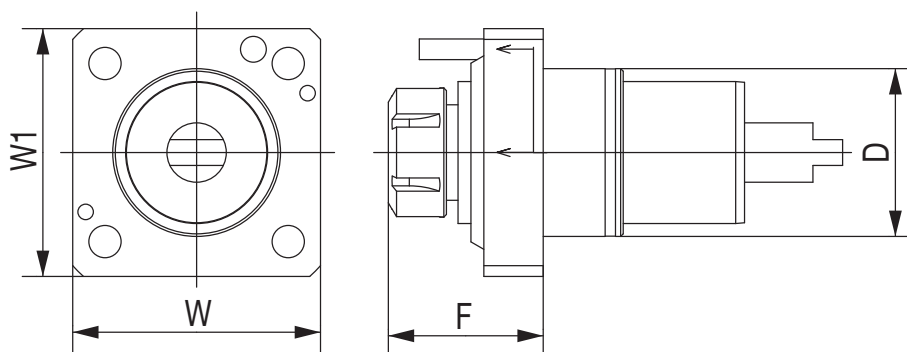

CODE N.	D	ER	INTERNAL COOLING	F	W	W1	TORQUE (Nm)	NMAX (Rpm)	RATIO	P (Bar)
124-06504	65	ER32	no	75	96	96	70	6000	1:1	-
124-06505	65	ER32	yes	75	96	96	70	6000	1:1	20

PORTAUTENSILE MOTORIZZATO RADIALE ANGULAR DRILLING AND MILLING HEAD

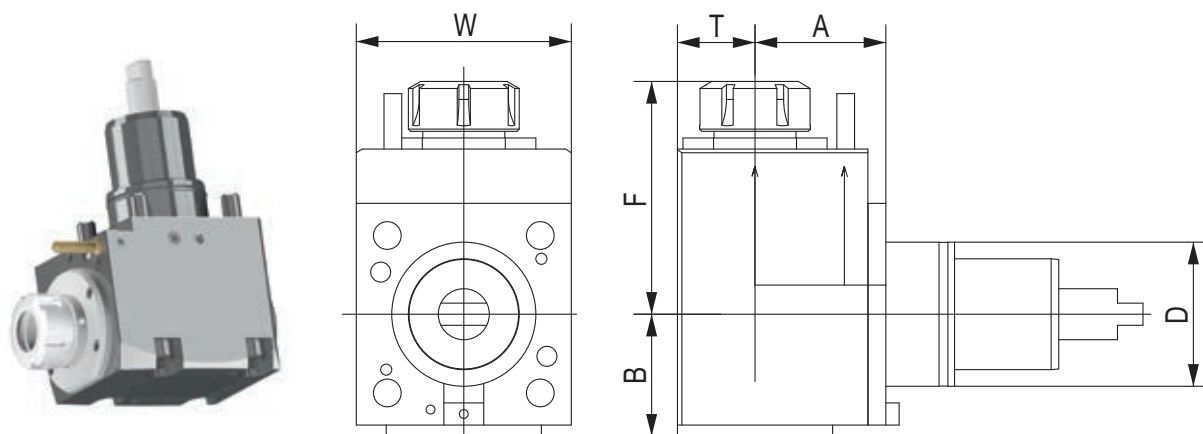

CODE N.	D	ER	INTERNAL COOLING	DI-RECTION	A	B	F	T	W	TORQUE (Nm)	NMAX (Rpm)	RATIO	P (Bar)
124-06506	65	ER32	no	right/left	65	59	110	38	96	70	6000	1:1	-
124-06507	65	ER32	yes	right/left	65	59	110	38	96	70	6000	1:1	20

TAPPO DI PROTEZIONE - PROTECTION COVER

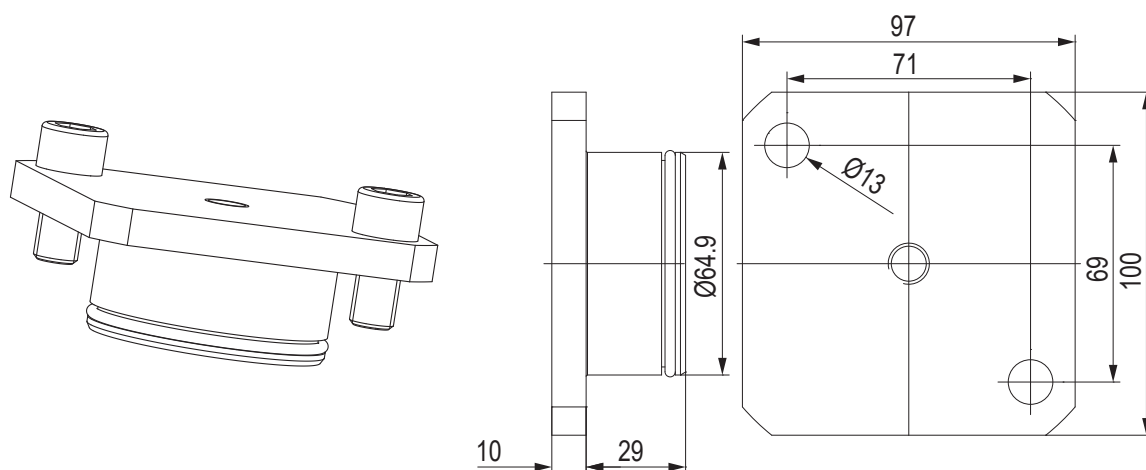

CODE N.	O RING
137-00250	823-101084



BUSSOLA PER PORTABARENI BORING BAR SLEEVE FOR TOOLHOLDER

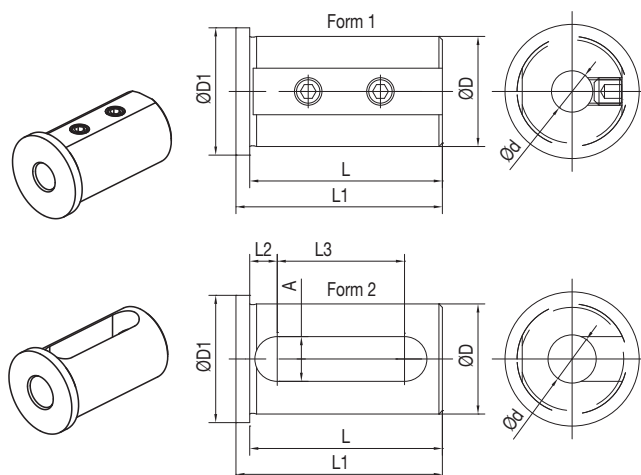

CODE N.	D	d	FORM	L	L1	L2	L3	A	D1
165-62551	25	8	1	46	50	-	-	-	30
165-62552	25	10	1	46	50	-	-	-	30
165-62553	25	12	1	46	50	-	-	-	30
165-62555	25	16	2	46	50	8	27	13	30
165-63352	32	8	1	56	60	-	-	-	37
165-63353	32	10	1	56	60	-	-	-	37
165-63354	32	12	1	56	60	-	-	-	37
165-63356	32	16	2	56	60	8	37	13	37
165-63358	32	20	2	56	60	8	37	13	37
165-63359	32	25	2	56	60	8	37	13	37

BUSSOLA PER PORTABARENI BORING BAR SLEEVE FOR TOOLHOLDER

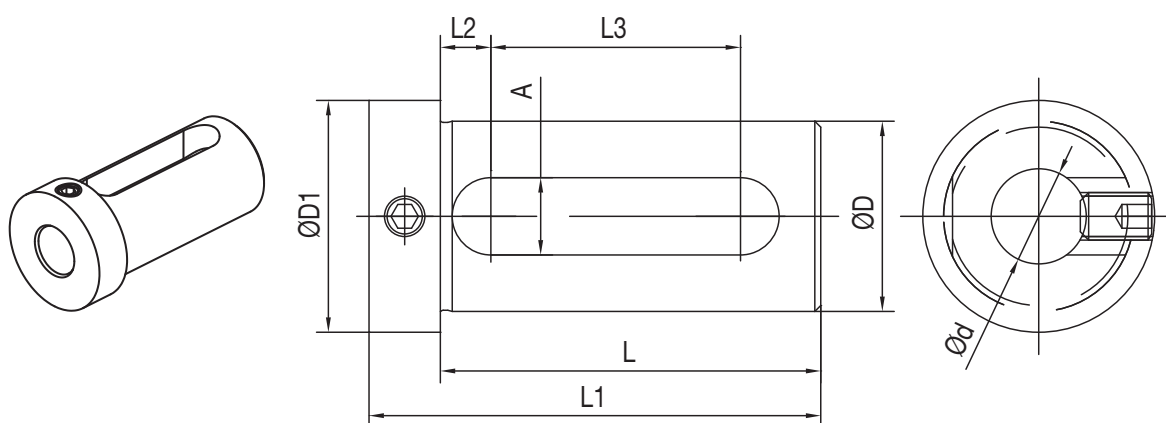

CODE N.	D	d	L	L1	L2	L3	A	D1
165-62545	25	12	54	66	8,5	32	13	32
165-62547	25	16	54	66	8,5	32	13	32
165-62549	25	20	54	66	8,5	32	13	32
165-63347	32	16	64	76	8,5	42	13	39
165-63349	32	20	64	76	8,5	42	13	39
165-63350	32	25	64	76	8,5	42	13	39

BUSSOLA PER PORTABARENI BORING BAR SLEEVE FOR TOOLHOLDER

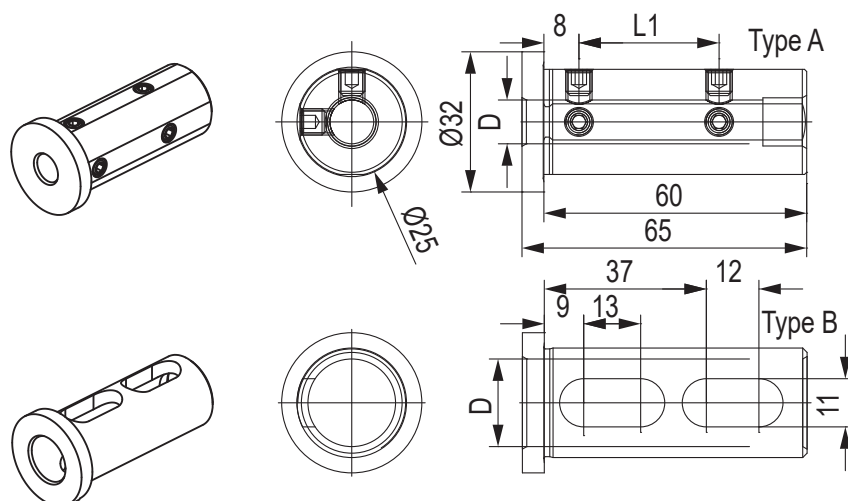

CODE N.	Ø	D	L1	TYPE	SCREW
115-62573	25	6	22	A	811-102011
115-62538	25	8	27	A	811-102018
115-62539	25	10	32	A	811-102017
115-62540	25	12	32	A	811-102017
115-62541	25	16	-	B	-



BUSSOLA PER PORTABARENI BORING BAR SLEEVE FOR TOOLHOLDER

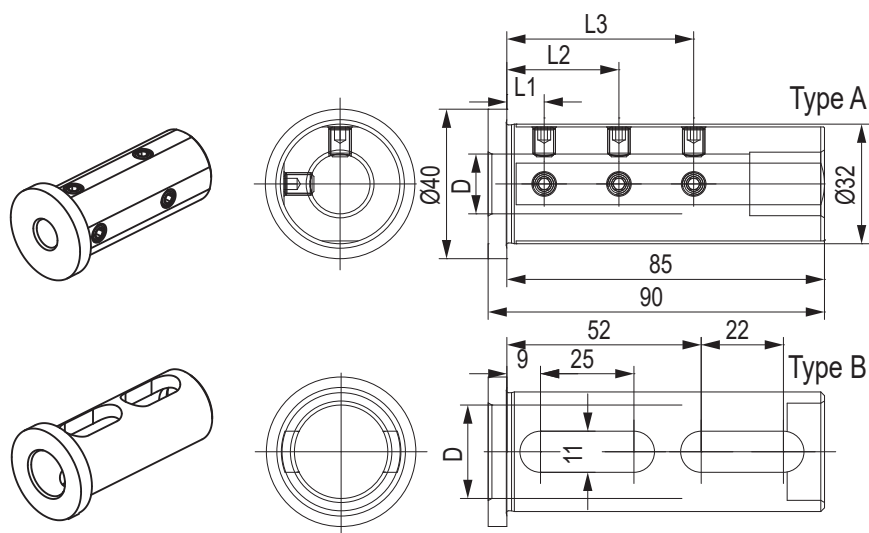

CODE N.	Ø	D	L1	L2	L3	TYPE	SCREW
115-63260	25	8	8	35	-	A	811-102019
115-63261	25	10	8	40	-	A	811-102019
115-63211	25	12	8	40	-	A	811-102018
115-63212	25	16	10	30	50	A	811-102018
115-63213	25	20	10	30	50	A	811-102017
115-63214	25	25	-	-	-	B	-

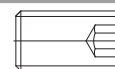

DOOSAN PUMA 230M/MS 240M/MS

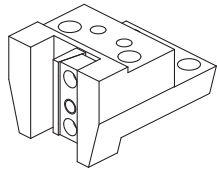

128-41501

Face and O.D.
cutting holder

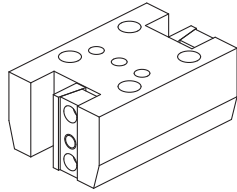

128-41502

Face and O.D.
cutting holder

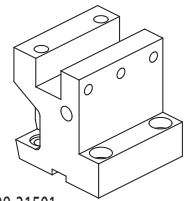

128-31501

Face and I.D.
cutting holder

Qualified tool
25x25 mm



Cut-off holder

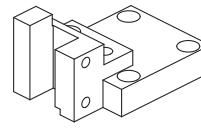

128-41503

Cut-off tool
25x25 mm



ACCESSORIES

Drill socket

- 114-34012 <MT1>
- 114-34013 <MT2>
- 114-34014 <MT3>

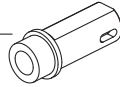

Boring bar sleeve

- 165-64089 (Ø10)
- 165-64090 (Ø12)
- 165-64091 (Ø16)

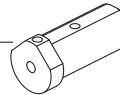

Boring bar sleeve

- 165-64092 (Ø20)
- 165-64093 (Ø25)
- 165-64094 (Ø32)

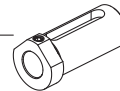

Throw-away drill socket

- 165-64095 (Ø20)
- 165-64096 (Ø25)

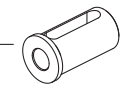

Boring bar sleeve

- 165-64247 (Ø8)
- 165-64248 (Ø10)
- 165-64249 (Ø12)

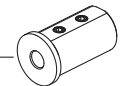

Boring bar sleeve

- 165-64251 (Ø16)
- 165-64253 (Ø20)
- 165-64254 (Ø25)
- 165-64255 (Ø32)

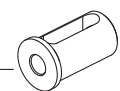

Boring bar sleeve

- 165-64241 (Ø16)
- 165-64243 (Ø20)
- 165-64244 (Ø25)
- 165-64245 (Ø32)

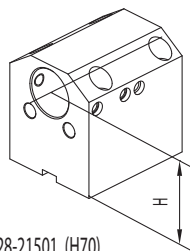
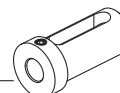

Boring bar holder

Ø40 mm

128-21501 (H70)
128-21521 (H60)

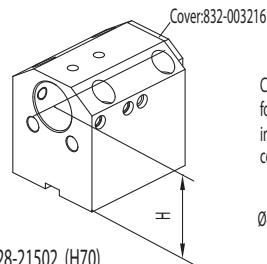

Combi toolholder
for boring bar and
insertdrill with internal
coolant

Ø40 mm

128-21502 (H70)
128-21522 (H60)

CONNECTION

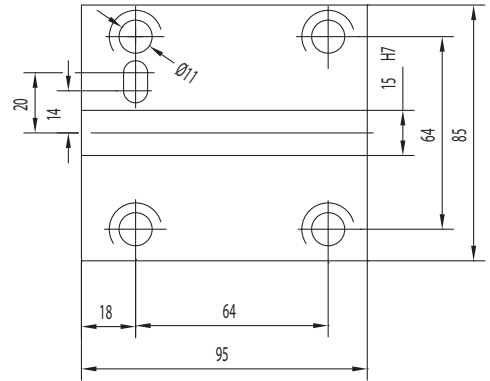

CONNECTION

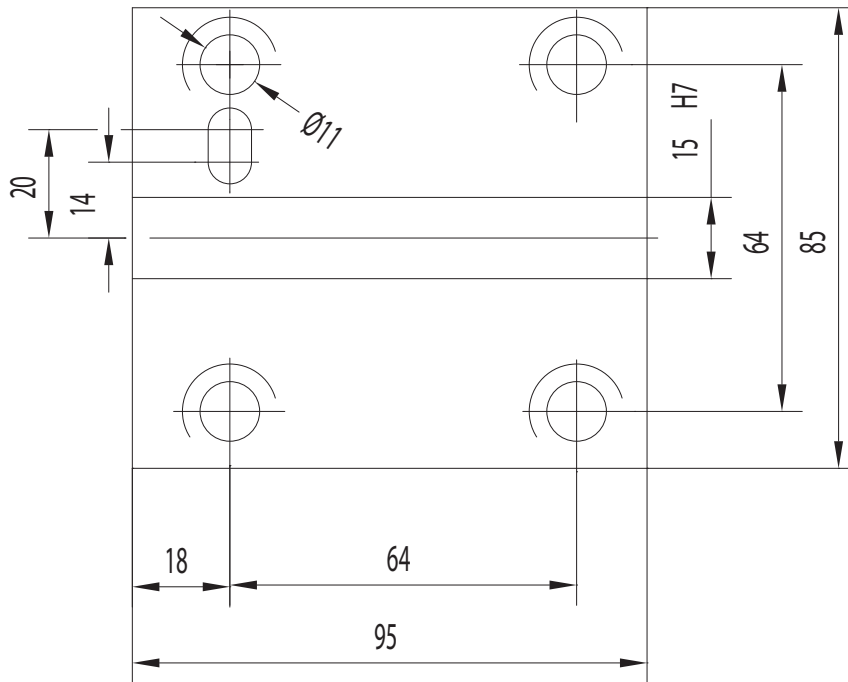

PORTAUTENSILE RADIALE - RADIAL TOOLHOLDERS

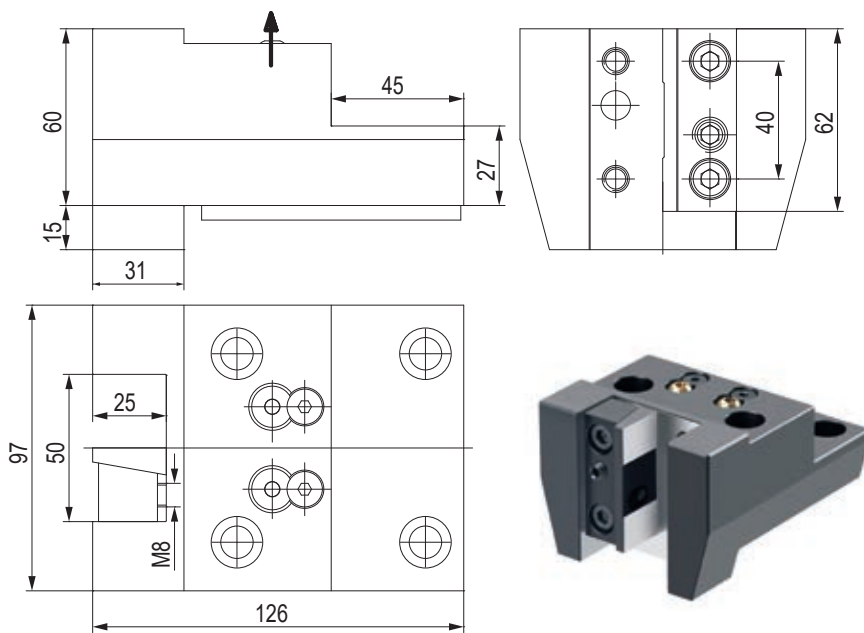

CODE N.	CLAMPING PLATE	KEY	SCREW FOR KEY	COOLANT BALL	SCREW FOR BALL
128-41501	832-018450	814-203230	811-101017	833-001470	811-108018

PORTAUTENSILE RADIALE - RADIAL TOOLHOLDERS

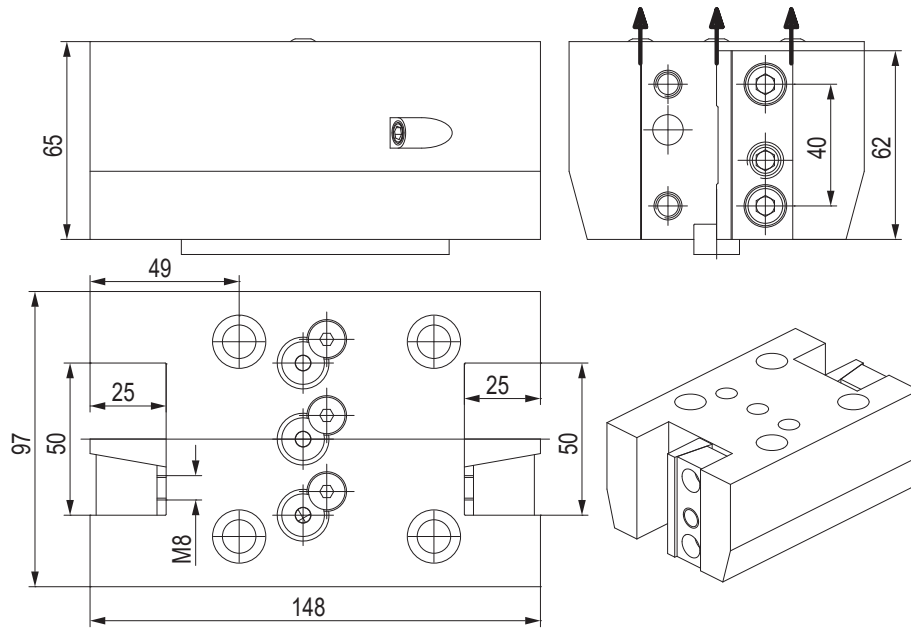

CODE N.	CLAMPING PLATE	KEY	SCREW FOR KEY	COOLANT BALL	SCREW FOR BALL
128-41502	832-018450	814-203230	811-101017	833-001470	811-108018

PORTALAMA - CUT-OFF TOOLHOLDERS

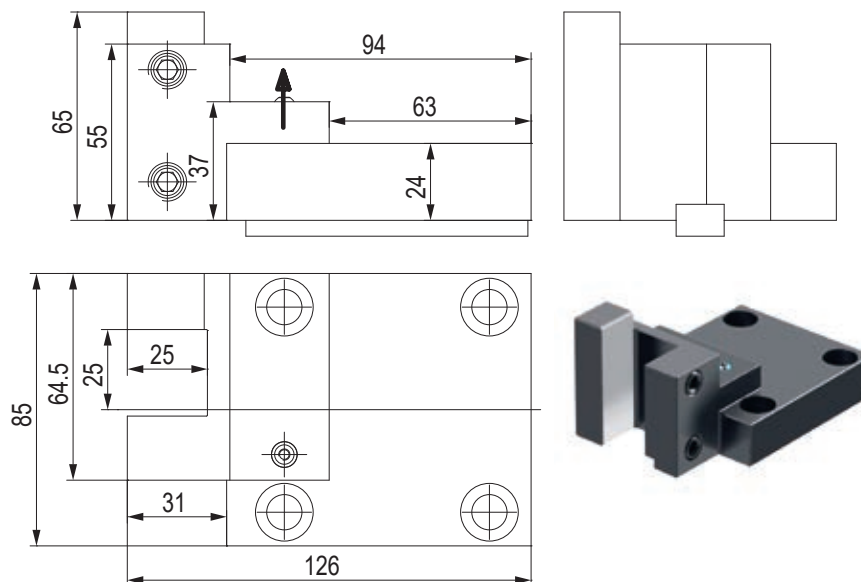

CODE N.	CLAMPING SCREW	KEY	SCREW FOR KEY	COOLANT NOZZLE
128-41503	811-102044	814-203230	811-101017	833-001060

PORTAUTENSILE ASSIALE - AXIAL TOOLHOLDERS

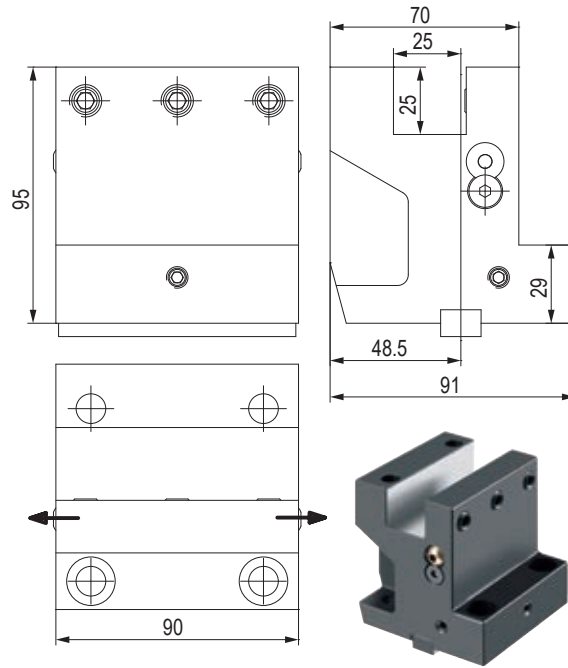

CODE N.	CLAMPING SCREW	KEY	SCREW FOR KEY	COOLANT BALL	SCREW FOR BALL
128-31501	811-102044	814-203230	811-101017	833-001470	811-108018

PORTAUTENSILE PER BARENI - TOOLHOLDER FOR BORING BAR

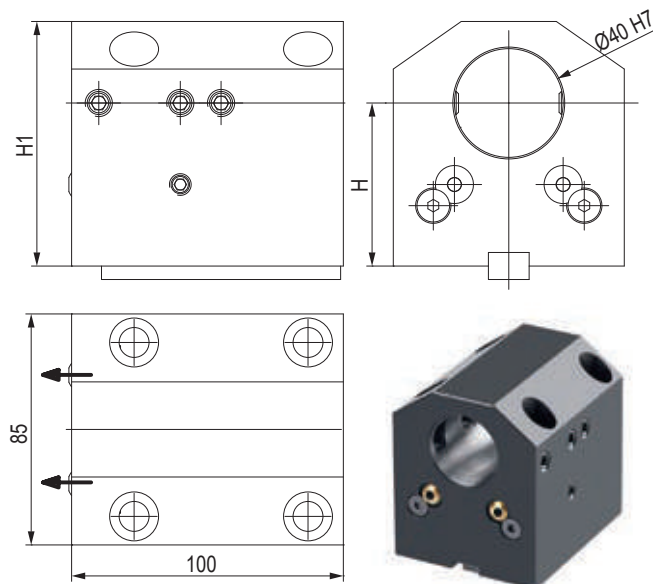

CODE N.	H	H1	CLAMPING SCREW	KEY	SCREW FOR KEY	COOLANT BALL	SCREW FOR BALL
128-21501	70	100	811-102038	814-203230	811-101017	833-001470	811-108018
128-21521	60	90	811-102038	814-203230	811-101017	833-001470	811-108018

PORTAUTENSILE COMBINATO PER BARENI E PUNTE A INSERTI COMBI TOOLHOLDER FOR BORING BAR AND INSERTDRILL

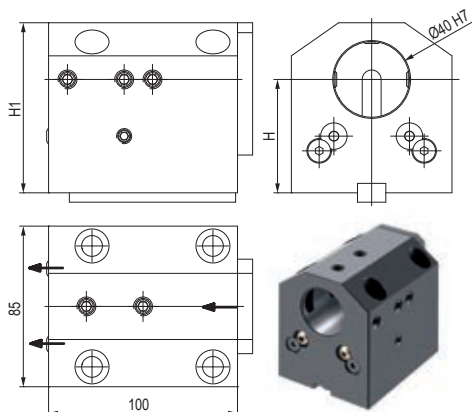

CODE N.	H	H1	CLAMPING SCREW1 (M10x20)	CLAMPING SCREW2 (M10x10)	KEY	SCREW FOR KEY
128-21502	70	100	811-102038	811-102035	814-203230	811-101017
128-21522	60	90	811-102038	811-102035	814-203230	811-101017

CODE N.	COOLANT BALL	SCREW FOR BALL	COVER	SCREW FOR COVER
128-21502	833-001470	811-108018	832-003216	811-101017
128-21522	833-001470	811-108018	832-003216	811-101017

BUSSOLA PER PORTABARENI DRILL SOCKET FOR TOOLHOLDER

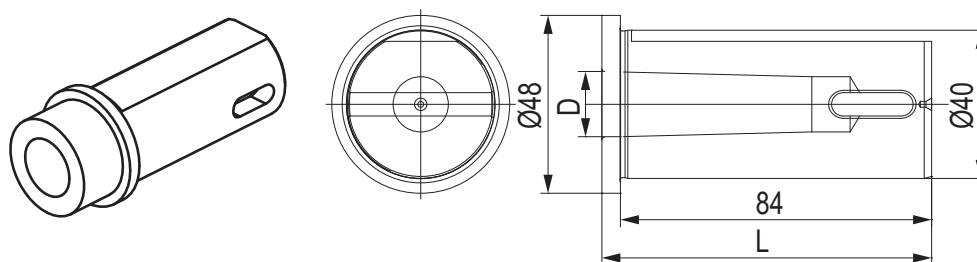

CODE N.	MORSE	D	L
114-34012	1	12,065	89
114-34013	2	17,780	89
114-34014	3	23,825	110

BUSSOLA PER PORTABARENI BORING BAR SLEEVE FOR TOOLHOLDER

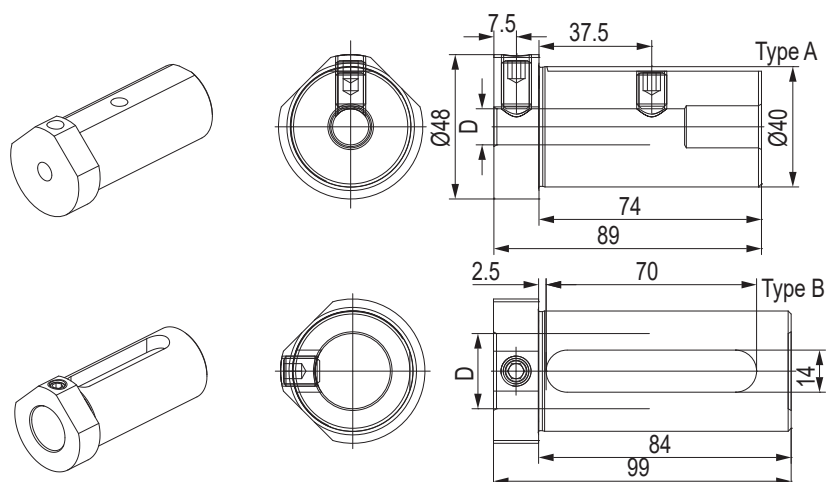

CODE N.	Ø	D	TYPE	SCREW1	SCREW2
165-64089	40	10	A	811-102037	811-102036
165-64090	40	12	A	811-102037	811-102036
165-64091	40	16	A	811-102037	811-102035
165-64092	40	20	B	811-102036	-
165-64093	40	25	B	811-102036	-
165-64094	40	32	B	811-102035	-

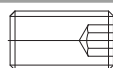

BUSSOLA PER PORTABARENI THROW-AWAY DRILL SOCKET FOR TOOLHOLDER

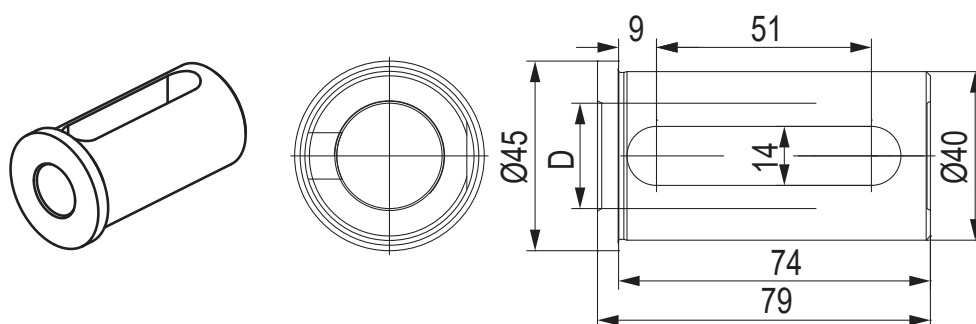

CODE N.	Ø	D
165-64095	40	20
165-64096	40	25

BUSSOLA PER PORTABARENI BORING BAR SLEEVE FOR TOOLHOLDER

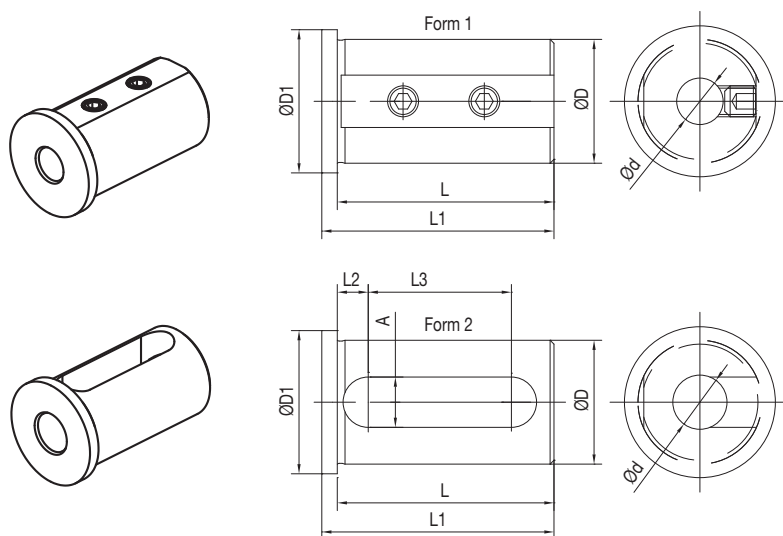

CODE N.	D	d	FORM	L	L1	L2	L3	A	D1
165-64247	40	8	1	71	75	-	-	-	45
165-64248	40	10	1	71	75	-	-	-	45
165-64249	40	12	1	71	75	-	-	-	45
165-64251	40	16	2	71	75	8	52	13	45
165-64253	40	20	2	71	75	8	52	13	45
165-64254	40	25	2	71	75	8	52	13	45
165-64255	40	32	2	71	75	8	52	13	45

BUSSOLA PER PORTABARENI BORING BAR SLEEVE FOR TOOLHOLDER

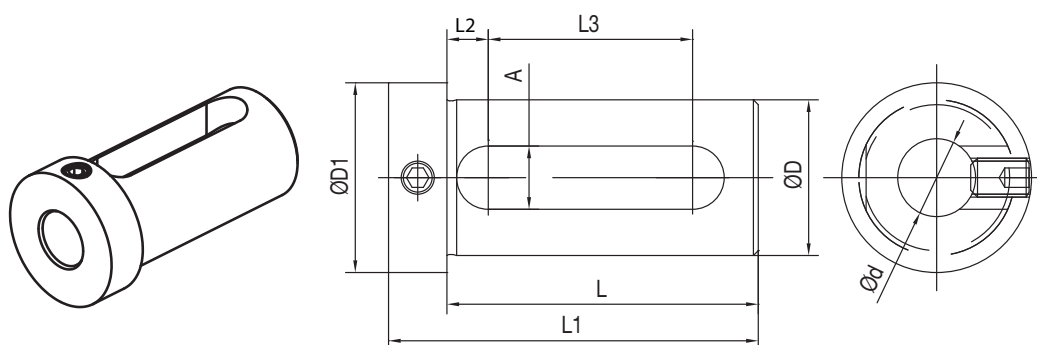

CODE N.	D	d	L	L1	L2	L3	A	D1
165-64241	40	16	74	88	9	51	14	48
165-64243	40	20	74	88	9	51	14	48
165-64244	40	25	74	88	9	51	14	48
165-64245	40	32	74	88	9	51	14	48

DOOSAN PUMA

230S
240S
LYNX210

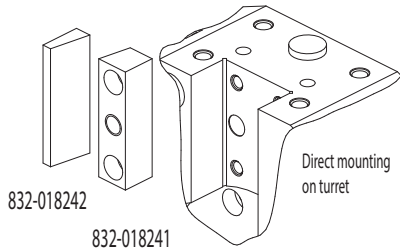

Qualified tool
25x25 mm



128-32009

Face and I.D.
cutting holder

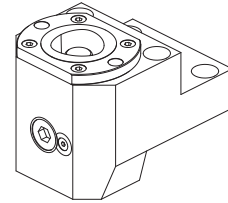
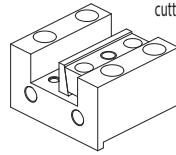

Face and O.D.
cutting holder
Polygonal

128-12073 (C40)
128-12063 (C50)

NEWS

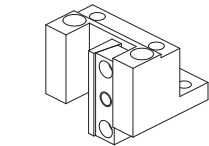

Face and O.D.
cutting holder

128-42012

ACCESSORIES

CONNECTION

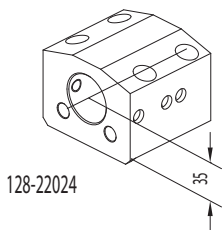

Boring bar holder
Ø40 mm

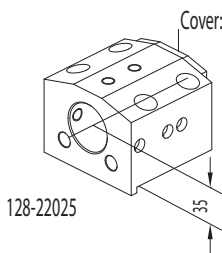

Cover: 832-003193
Combi toolholder
for boring bar and
insertdrill with internal
coolant
Ø40 mm

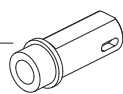

Drill socket
114-34012 <MT1>
114-34013 <MT2>
114-34014 <MT3>

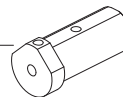

Boring bar sleeve
165-64089 (Ø10)
165-64090 (Ø12)
165-64091 (Ø16)

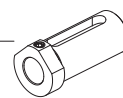

Boring bar sleeve
165-64092 (Ø20)
165-64093 (Ø25)
165-64094 (Ø32)

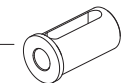

Throw-away drill socket
165-64095 (Ø20)
165-64096 (Ø25)

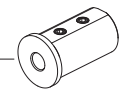

Boring bar sleeve
165-64247 (Ø8)
165-64248 (Ø10)
165-64249 (Ø12)

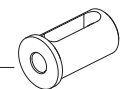

Boring bar sleeve
165-64251 (Ø16)
165-64253 (Ø20)
165-64254 (Ø25)
165-64255 (Ø32)

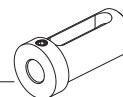

Boring bar sleeve
165-64241 (Ø16)
165-64243 (Ø20)
165-64244 (Ø25)
165-64245 (Ø32)

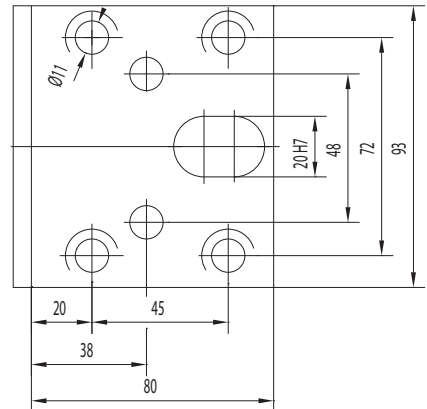

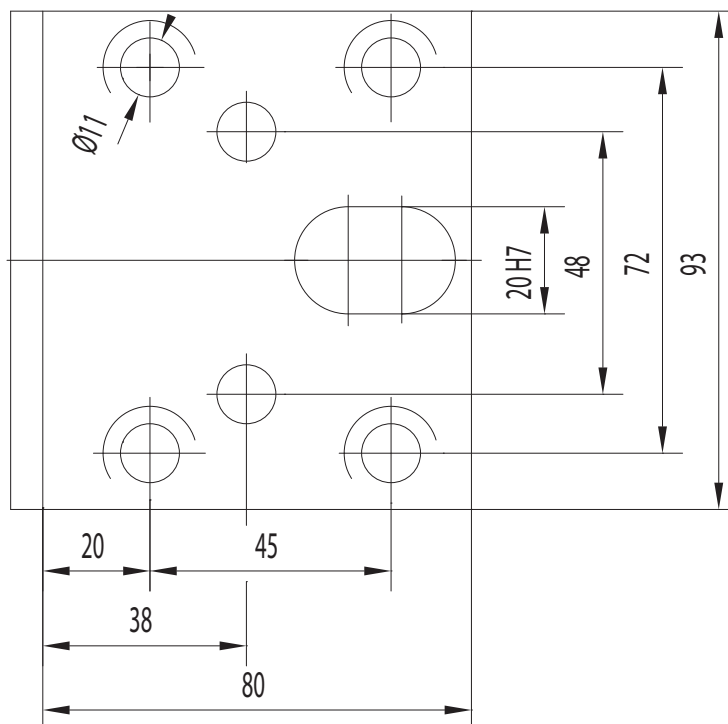

CONNECTION

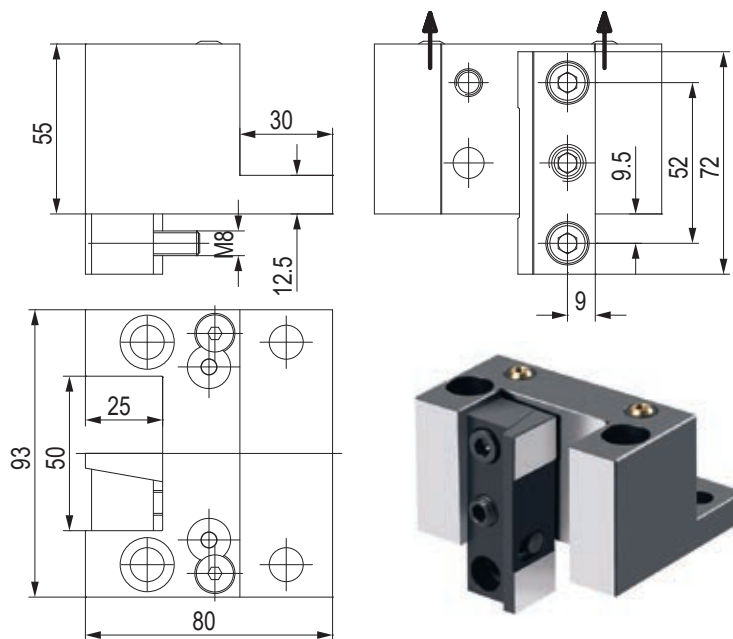

PORTAUTENSILE RADIALE - RADIAL TOOLHOLDERS

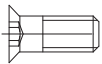

CODE N.	CLAMPING PLATE	COOLANT BALL	SCREW FOR BALL
128-42012			
128-42012	832-018240	833-001470	811-108018

PORTAUTENSILE ASSIALE - AXIAL TOOLHOLDERS

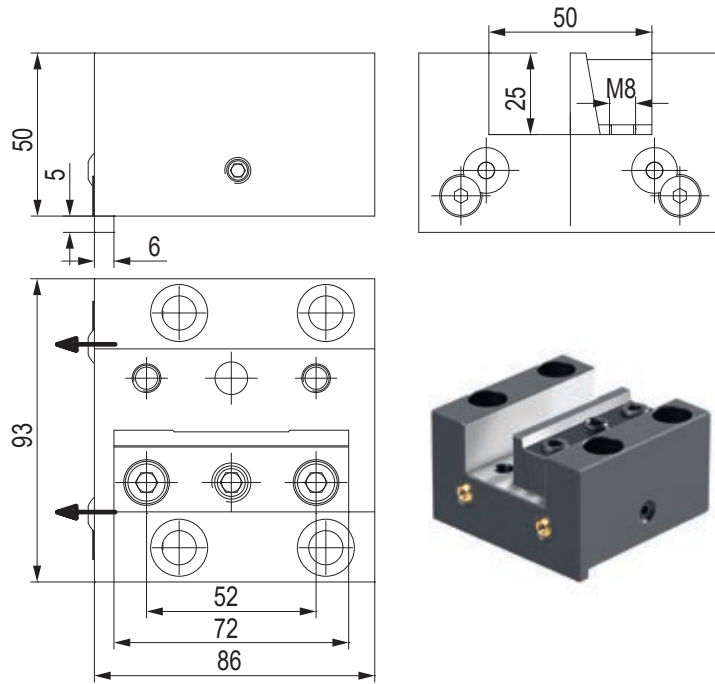

CODE N.	CLAMPING PLATE	COOLANT BALL	SCREW FOR BALL
128-32009	832-018240	833-001470	811-108018

PORTAUTENSILE PER BARENI - TOOLHOLDER FOR BORING BAR

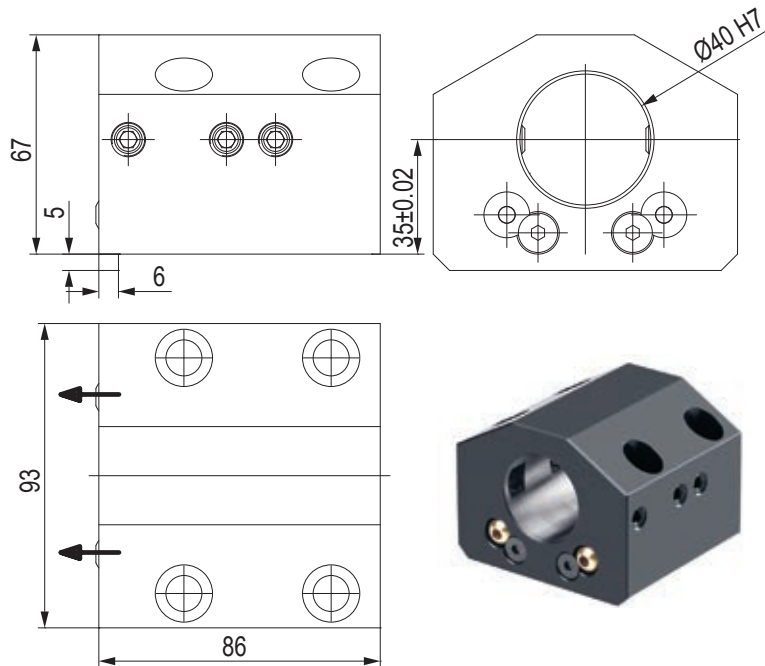

CODE N.	CLAMPING SCREW	COOLANT BALL	SCREW FOR BALL
128-22024	811-102039	833-001470	811-108018

PORTAUTENSILE COMBINATO PER BARENI E PUNTE A INSERTI COMBI TOOLHOLDER FOR BORING BAR AND INSERTDRILL

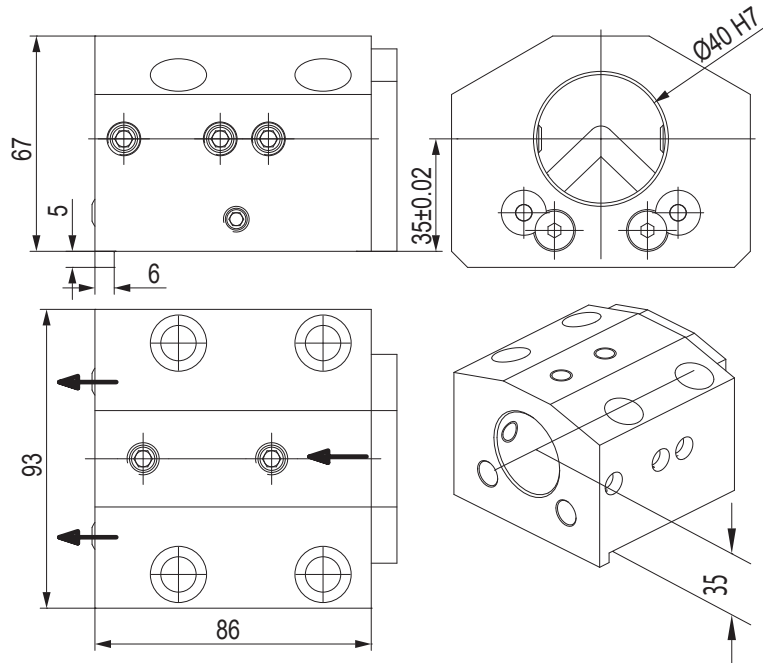

CODE N.	CLAMPING SCREW1 (M10X25)	CLAMPING SCREW2 (M10X12)	COOLANT BALL	SCREW FOR BALL	COVER	SCREW FOR COVER
128-22025	811-102039	811-102036	833-001470	811-108018	832-003193	811-108024

PORTAUTENSILE CON USCITA POLIGONALE POLIGONAL TOOLHOLDERS

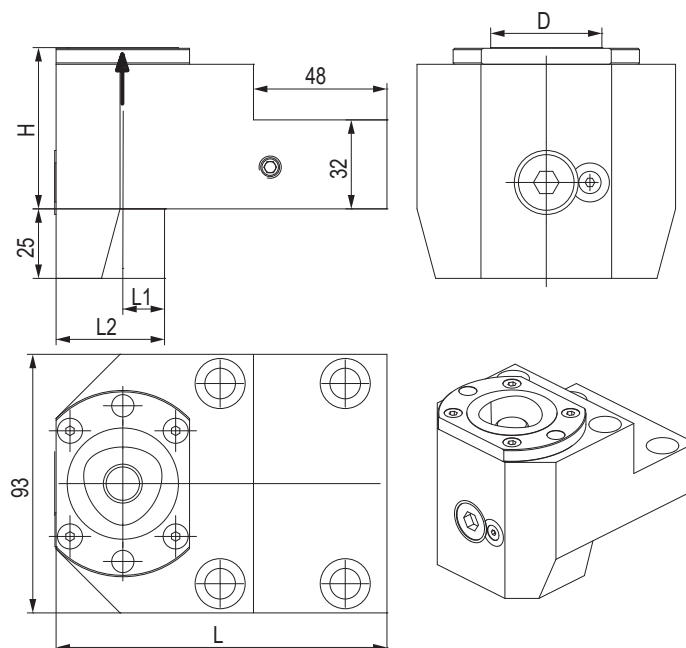

CODE N.	CAPTO	D	H	L	L1	L2	CLAMPING UNIT
128-12073	C40	40	58	119	15	39	CXC40-10
128-12063	C50	50	70	129	17	49	CXC50-10

BUSSOLA PER PORTABARENI DRILL SOCKET FOR TOOLHOLDER

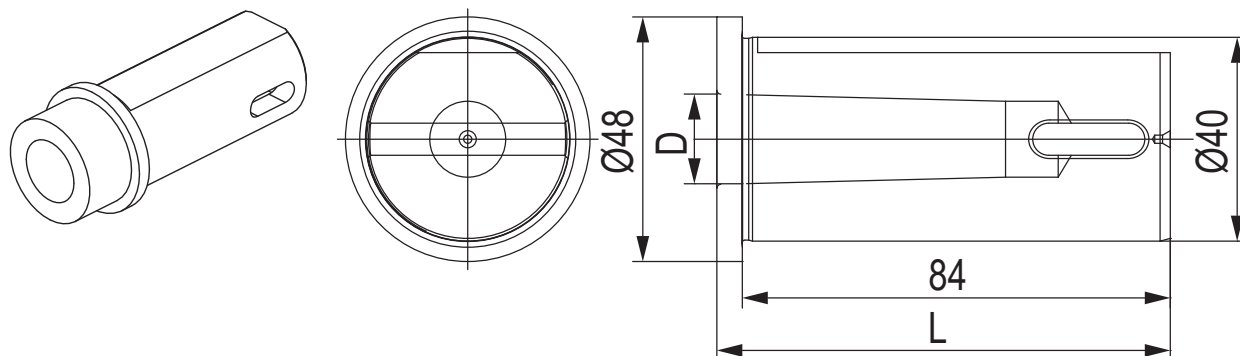

CODE N.	MORSE	D	L
114-34012	1	12,065	89
114-34013	2	17,780	89
114-34014	3	23,825	110

BUSSOLA PER PORTABARENI BORING BAR SLEEVE FOR TOOLHOLDER

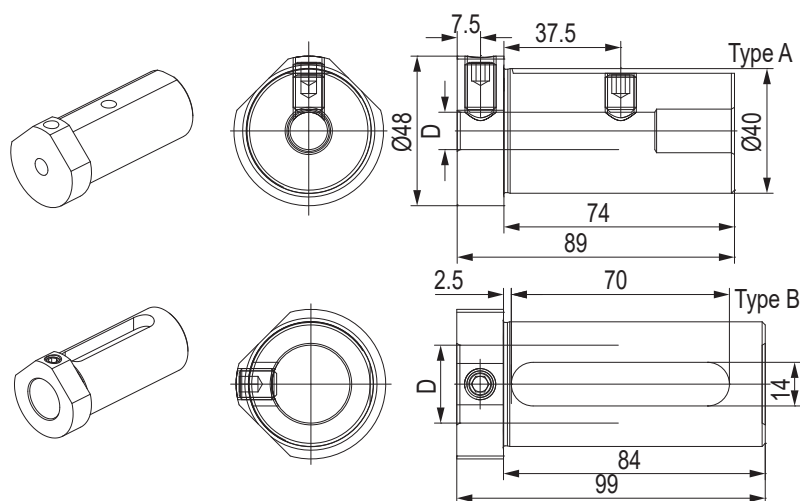

CODE N.	Ø	D	TYPE	SCREW1	SCREW2
165-64089	40	10	A	811-102037	811-102036
165-64090	40	12	A	811-102037	811-102036
165-64091	40	16	A	811-102037	811-102035
165-64092	40	20	B	811-102036	-
165-64093	40	25	B	811-102036	-
165-64094	40	32	B	811-102035	-

BUSSOLA PER PORTABARENI BORING BAR SLEEVE FOR TOOLHOLDER

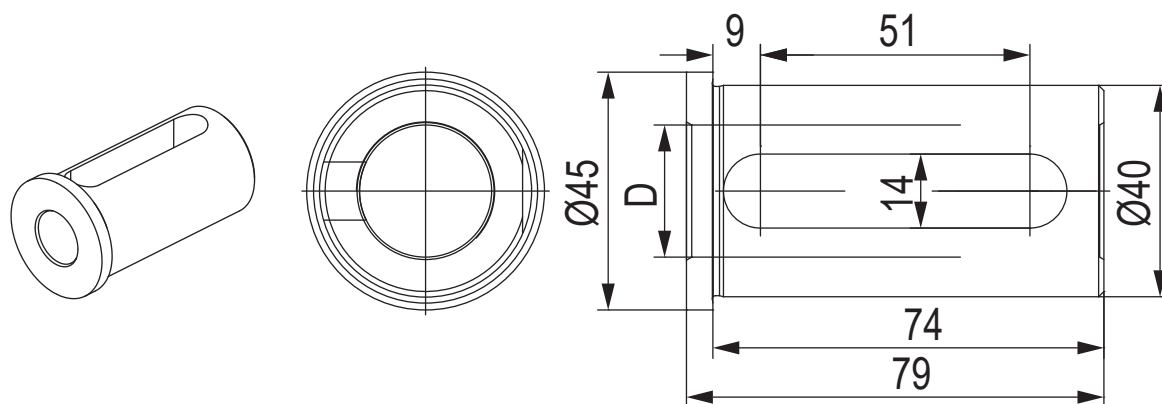

CODE N.	Ø	D
165-64095	40	20
165-64096	40	25

BUSSOLA PER PORTABARENI BORING BAR SLEEVE FOR TOOLHOLDER

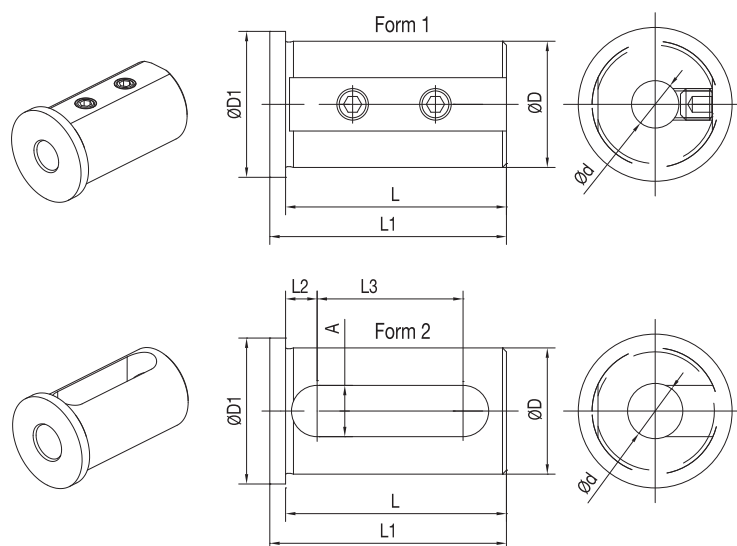

CODE N.	D	d	FORM	L	L1	L2	L3	A	D1
165-64247	40	8	1	71	75	-	-	-	45
165-64248	40	10	1	71	75	-	-	-	45
165-64249	40	12	1	71	75	-	-	-	45
165-64251	40	16	2	71	75	8	52	13	45
165-64253	40	20	2	71	75	8	52	13	45
165-64254	40	25	2	71	75	8	52	13	45
165-64255	40	32	2	71	75	8	52	13	45

BUSSOLA PER PORTABARENI BORING BAR SLEEVE FOR TOOLHOLDER

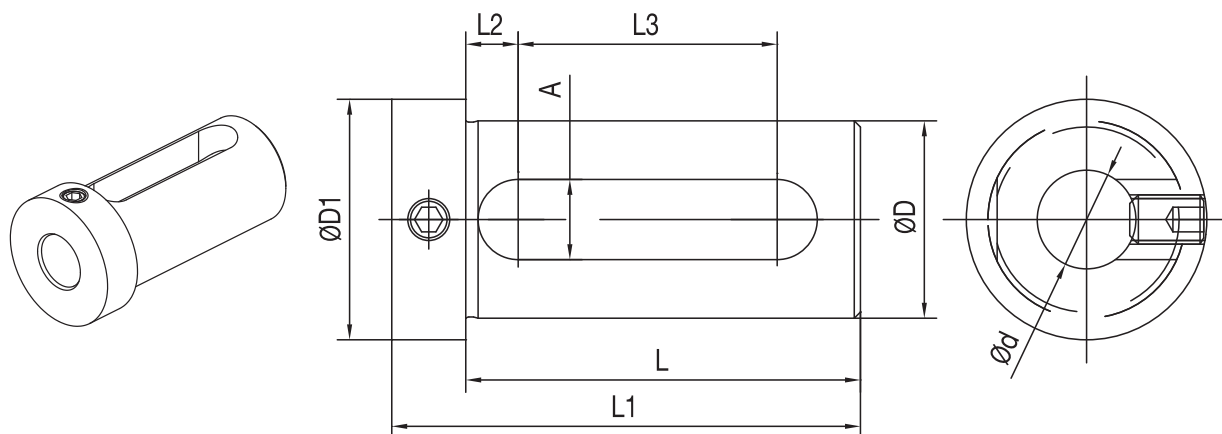

CODE N.	D	d	L	L1	L2	L3	A	D1
165-64241	40	16	74	88	9	51	14	48
165-64243	40	20	74	88	9	51	14	48
165-64244	40	25	74	88	9	51	14	48
165-64245	40	32	74	88	9	51	14	48



DOOSAN
(BMT45)

LYNX 2100LYA/LYB (24 POSITION INDEX)
LYNX 2100MA/220 (LMSA,LMSC)
220 (LSYA,LSYC), 220 (M,LM)
LYNX 220 (MA,LMA,MC,LMC)
220 (YA,YC,LYA,LYC)
PUMA MX1600 (T,ST)

HARDINGE BMT45
SMEC PL1600 (M,CM)

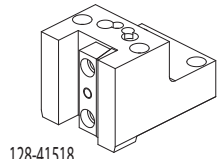

128-41518

Face and O.D. cutting holder

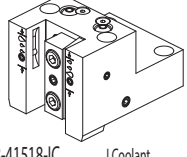

128-41518-IC

I.Coolant

Face and O.D. cutting holder

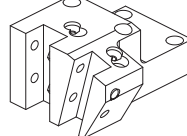

128-41519

Face and O.D. cutting holder

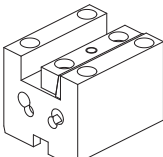

128-31511

Face and O.D. cutting holder

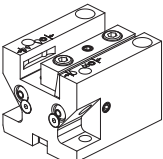

128-31511-IC

I.Coolant

Face and O.D. cutting holder



Protection cover
137-00252

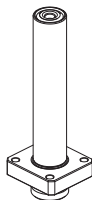

Control pin
137-00197

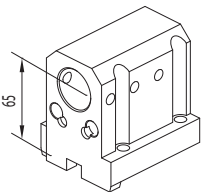

128-21529

Toolholder for boring bar

Ø32 mm

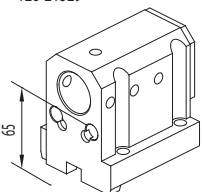

128-21530 (D32)
128-21547 (D40)

Combi toolholder

for boring bar and insertdrill

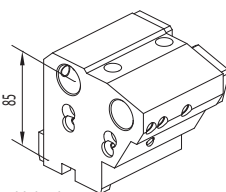

128-21531

Combi toolholder for boring bar

2xØ25 mm

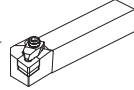

Qualified tool
20x20 mm

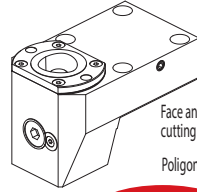

128-11572

Face and O.D. cutting holder

Poligonal C40

NEWS

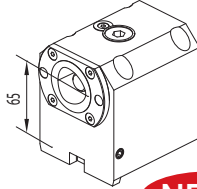

128-11571

Boring bar holder
Poligonal C40

NEWS

ACCESSORIES

D32

Drill socket

- 114-33208 <MT1>
- 114-33209 <MT2>

Boring bar sleeve

- 115-63260 (Ø8)
- 115-63261 (Ø10)
- 115-63211 (Ø12)
- 115-63212 (Ø16)
- 115-63213 (Ø20)

Boring bar sleeve

- 115-63214 (Ø25)

Boring bar sleeve

- 165-63352 (Ø8)
- 165-63353 (Ø10)
- 165-63354 (Ø12)

Boring bar sleeve

- 165-63356 (Ø16)
- 165-63358 (Ø20)
- 165-63359 (Ø25)

Boring bar sleeve

- 165-63347 (Ø16)
- 165-63349 (Ø20)
- 165-63350 (Ø25)

Boring bar sleeve

- 115-62538 (Ø8 mm)
- 115-62539 (Ø10 mm)
- 115-62540 (Ø12 mm)

Boring bar sleeve

- 115-62541 (Ø16 mm)



124-04501
124-04502 I.Coolant



124-04503
124-04504 I.Coolant

FAST-IN

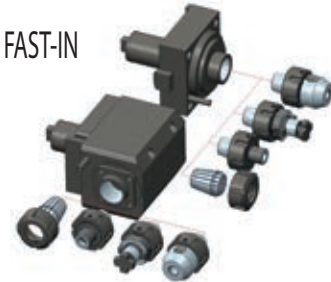

Cut-off holder

Cut-off tool
26 mm

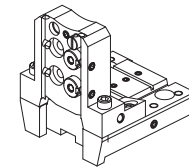

128-11546

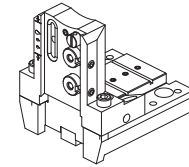

128-11546-IC

I.Coolant

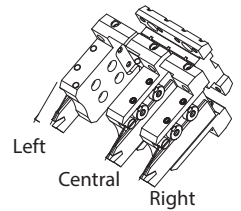

Left
Central
Right

CONNECTION

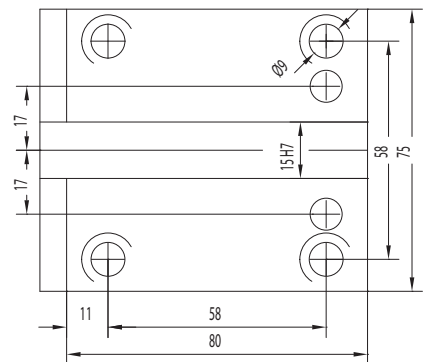

D40

- 165-64247 (Ø8)
- 165-64248 (Ø10)
- 165-64249 (Ø12)

- 165-64251 (Ø16)
- 165-64253 (Ø20)
- 165-64254 (Ø25)
- 165-64255 (Ø32)

- 165-64241 (Ø16)
- 165-64243 (Ø20)
- 165-64244 (Ø25)
- 165-64245 (Ø32)

Boring bar sleeve

- 165-62551 (Ø8)
- 165-62552 (Ø10)
- 165-62553 (Ø12)

Boring bar sleeve

- 165-62555 (Ø16)
- 165-62557 (Ø20)

Boring bar sleeve

- 165-62545 (Ø12)
- 165-62547 (Ø16)
- 165-62549 (Ø20)

CONNECTION

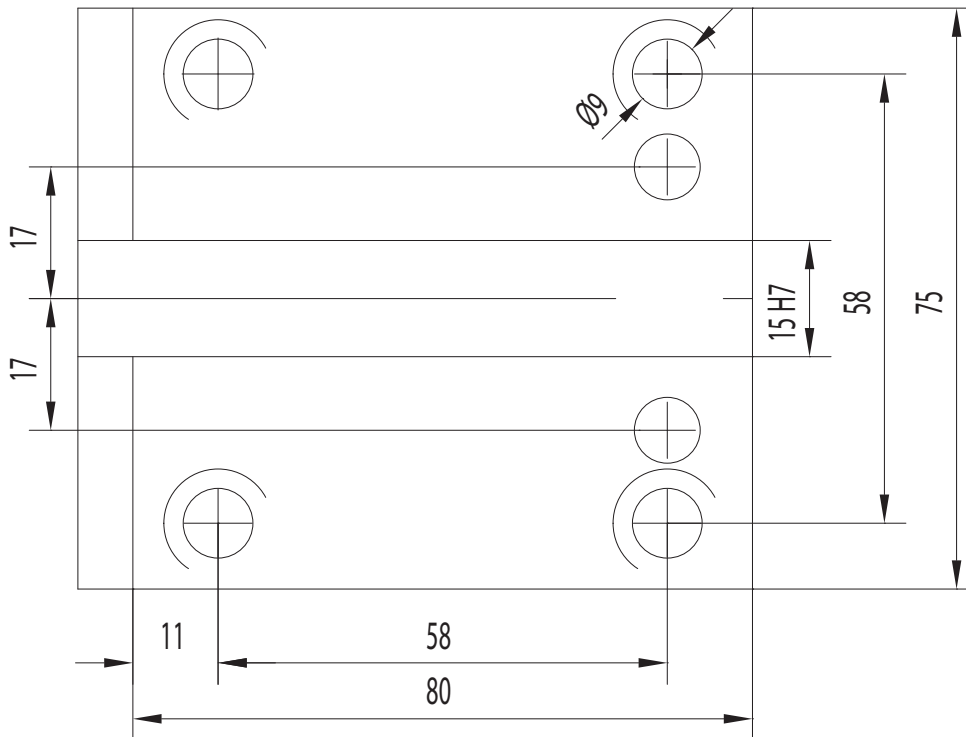

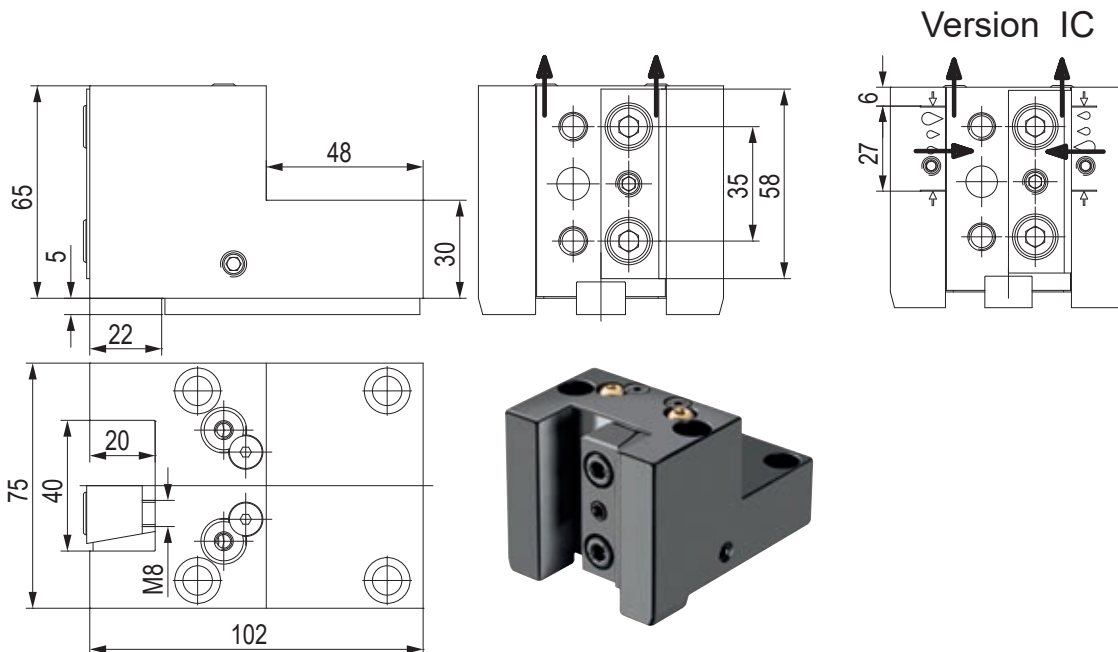

PORTAUTENSILE RADIALE - RADIAL TOOLHOLDERS



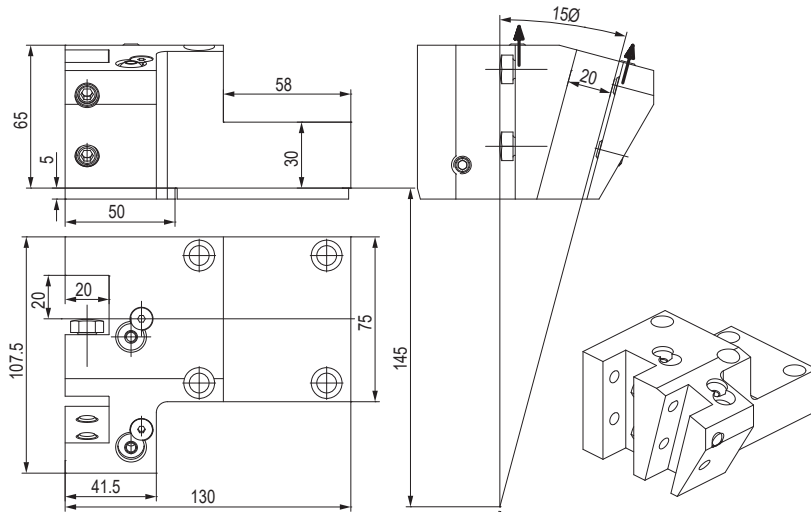

CODE N.	INTERNAL COOLANT	CLAMPING PLATE	KEY	SCREW FOR KEY	COOLANT BALL	SCREW FOR BALL
128-41518	NO	832-007160	814-203450	811-101016	833-001410	811-108024
128-41518-IC	YES	832-007160	814-203450	811-101016	833-001410	811-108024

PORTAUTENSILE RADIALE - RADIAL TOOLHOLDERS

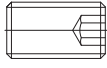
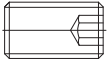

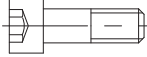

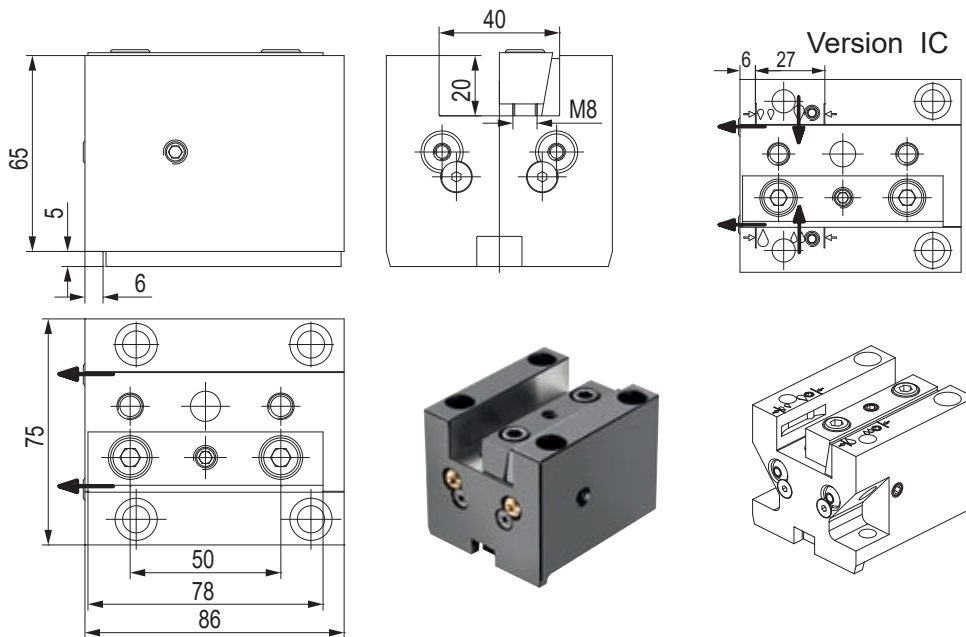

CODE N.	CLAMPING SCREW 0°	CLAMPING SCREW 15°-M10X12	CLAMPING SCREW 15°-M10X16
			
128-41519	811-301128	811-102036	811-102037

CODE N.	KEY	SCREW FOR KEY	COOLANT BALL	SCREW FOR BALL
				
128-41519	814-203450	811-101016	833-001410	811-108024

PORTAUTENSILE ASSIALE - AXIAL TOOLHOLDERS

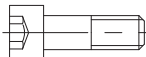

CODE N.	INTERNAL COOLANT	CLAMPING PLATE	KEY	SCREW FOR KEY	COOLANT BALL	SCREW FOR BALL
						
128-31511	NO	832-007200	814-203450	811-101016	833-001410	811-108024
128-31511-IC	YES	832-007200	814-203450	811-101016	833-001410	811-108024

PORTALAMA - CUT-OFF HOLDERS

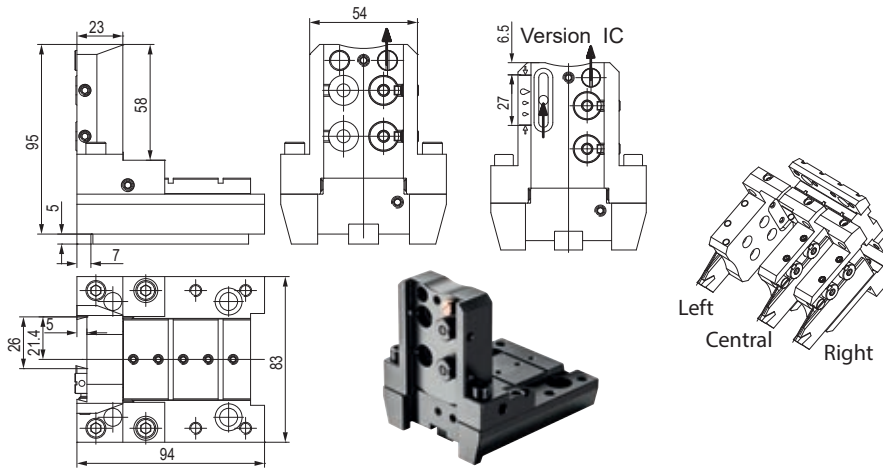

CODE N.	INTERNAL COOLANT	KEY	SCREW FOR KEY	COOLANT NOZZLE	O RING FOR COOLANT NOZZLE	O RING FOR INT. COOLANT	O RING FOR BODY
128-11546	NO	814-203450	811-101015	833-001490	823-101058	-	823-101061
128-11546-IC	YES	814-203450	811-101015	833-001490	823-101058	823-201140	823-101061

CODE N.	SHIM PLATE	SCREW FOR PLATE	CLAMPING PIN	SPRING	CLAMPING SCREW	SCREW
128-11546	832-014448	811-108037	832-014447	824-300012	811-101028	811-104013
128-11546-IC	832-014448	811-108037	832-014447	824-300012	811-101028	811-104013

PORTAUTENSILE PER BARENI - TOOLHOLDER FOR BORING BAR

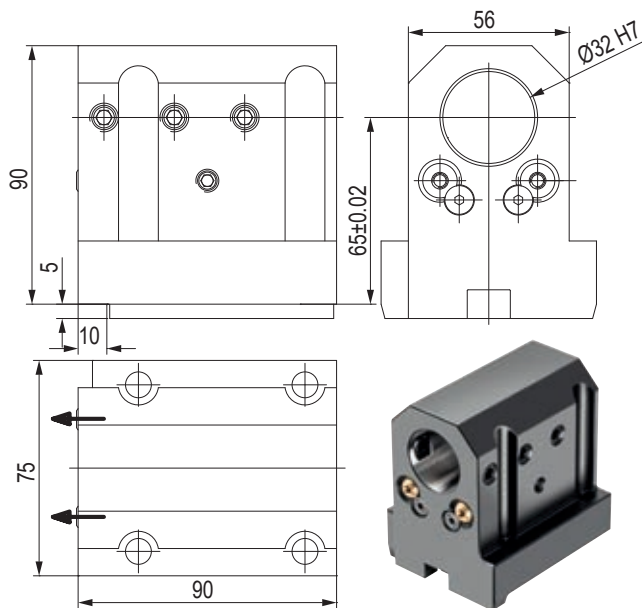

CODE N.	CLAMPING SCREW	KEY	SCREW FOR KEY	COOLANT BALL	SCREW FOR BALL
128-21529	811-102036	814-203450	811-101016	833-001410	811-108024

PORTAUTENSILE COMBINATO PER BARENI E PUNTE A INSERTI COMBI TOOLHOLDER FOR BORING BAR AND INSERTDRILL

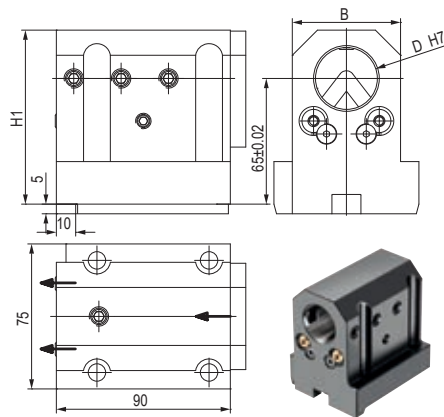

CODE N.	D	B	H1	CLAMPING SCREW1 (M10X12)	CLAMPING SCREW2 (M10X10)	KEY	SCREW FOR KEY
128-21530	32	56	90	811-102036	811-102035	814-203450	811-101016
128-21547	40	63	94	811-102036	811-102035	814-203450	811-101016

	COOLANT BALL	SCREW FOR BALL	COVER	SCREW FOR COVER
128-21530	833-001410	811-108024	832-003361	811-101016
128-21547	833-001410	811-108024	832-003398	811-101016

PORTAUTENSILE COMBINATO PER BARENI COMBI TOOLHOLDER FOR BORING BAR

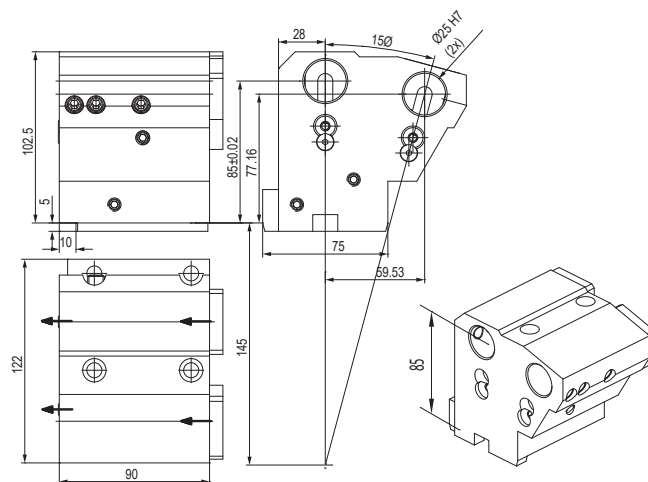

CODE N.	CLAMPING SCREW1 (M10X12)	CLAMPING SCREW2 (M10X10)	KEY	SCREW FOR KEY
128-21531	811-102037	811-102036	814-203450	811-101016

CODE N.	COOLANT BALL	SCREW FOR BALL	COVER	SCREW FOR COVER
128-21531	833-001410	811-108024	832-003367	811-101010

PORTAUTENSILE CON USCITA POLIGONALE POLIGONAL TOOLHOLDERS

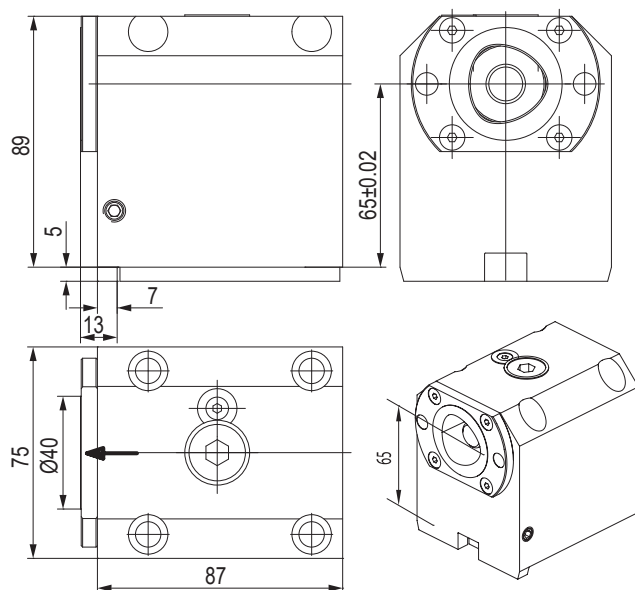

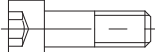
CODE N.	CAPTO	CLAMPING UNIT	KEY	SCREW FOR KEY
128-11571	C40	CXC40-10		
			814-203450	811-101016

PORTAUTENSILE CON USCITA POLIGONALE POLIGONAL TOOLHOLDERS

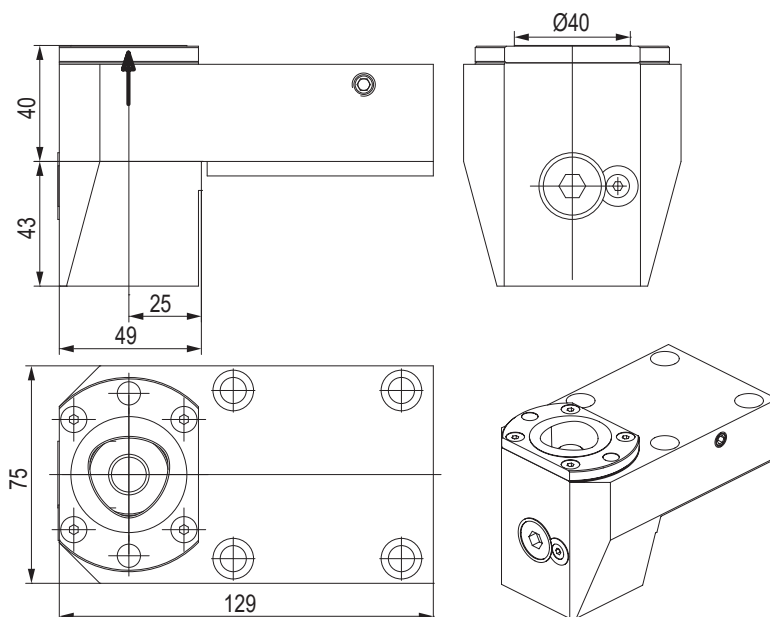

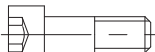
CODE N.	CAPTO	CLAMPING UNIT	KEY	SCREW FOR KEY
128-11572	C40	CXC40-10		
			814-203450	811-101016

PORTAUTENSILE MOTORIZZATO ASSIALE STRAIGHT DRILLING AND MILLING HEAD

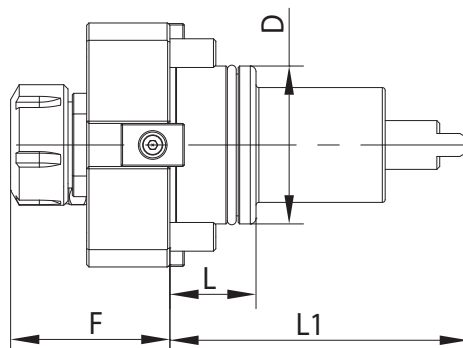
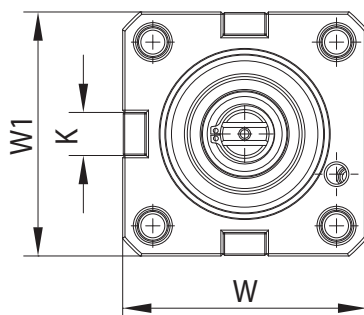

CODE N.	ER	D	F	K	L	L1	W	W1	MAX SPEED (Rpm)	I	MAX. TORQUE (Nm)	INTERNAL COOLING
124-04501	ER25	45	67.6	15	40	84	78.5	75	6000	1:1	50	no
124-04502	ER25	45	67.6	15	40	84	78.5	75	6000	1:1	50	yes

PORTAUTENSILE MOTORIZZATO RADIALE ANGULAR DRILLING AND MILLING HEAD

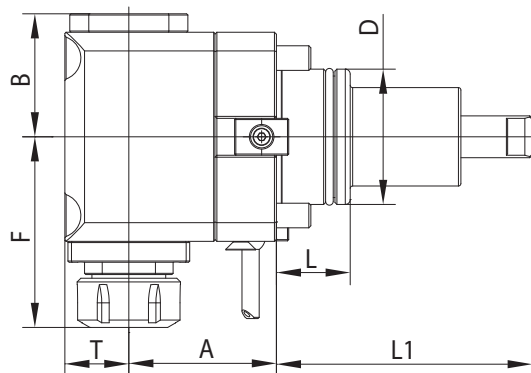
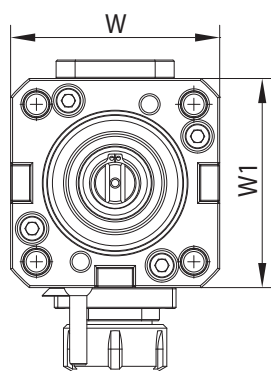
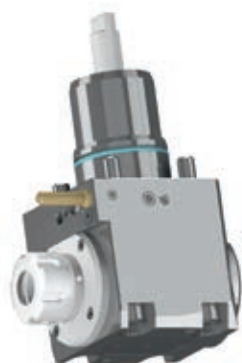

CODE N.	ER	D	A	B	F	L	L1	T	W	W1	MAX SPEED (Rpm)	I	MAX. TORQUE (Nm)	INTERNAL COOLING	P Bar
124-04503	ER25	45	65	57	97.6	40	84	36.5	75	83	6000	1:1	50	no	-
124-04504	ER25	45	65	57	97.6	40	84	36.5	75	83	6000	1:1	50	yes	20

BARRA DI CONTROLLO - CONTROL PIN

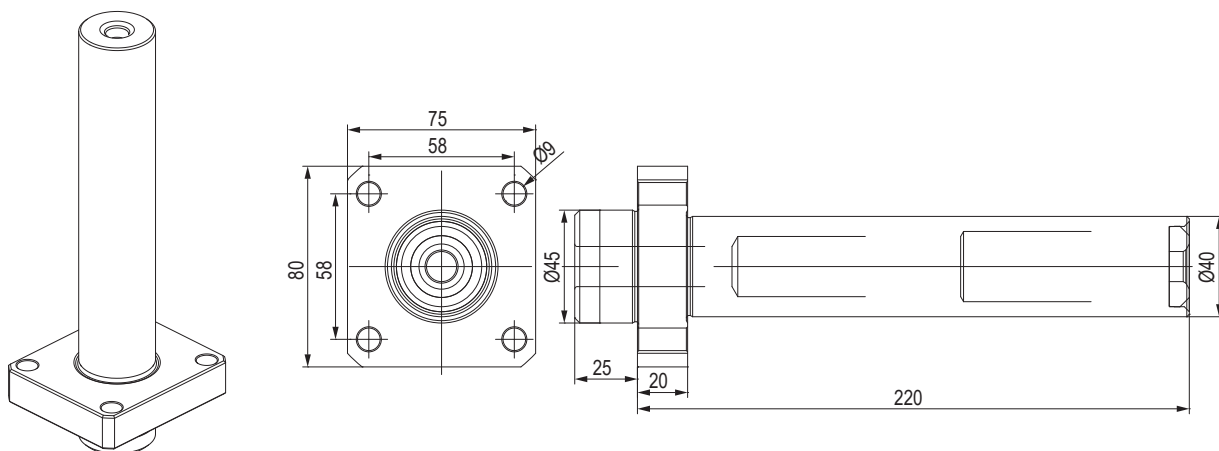

CODE N.

137-00197

TAPPO DI PROTEZIONE - PROTECTION COVER

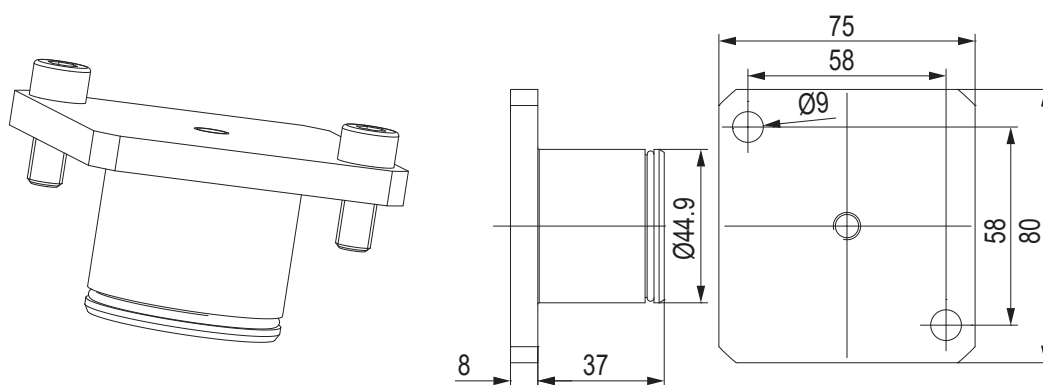

CODE N.

O RING



137-00252

823-101066

BUSSOLA PER PORTABARENI DRILL SOCKET FOR TOOLHOLDER

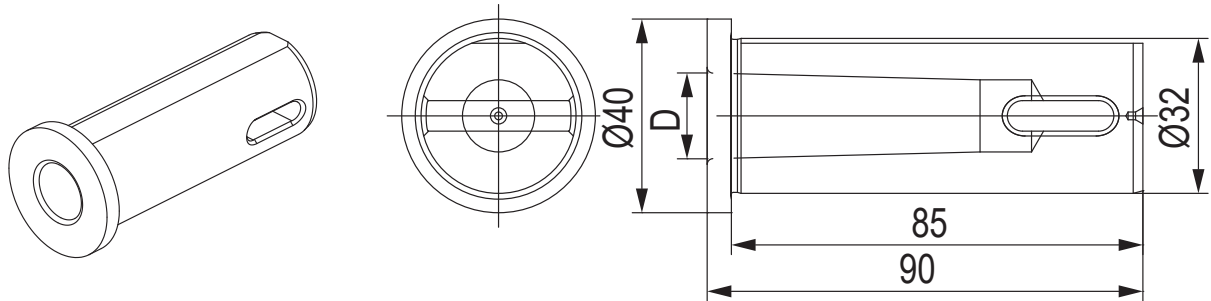

CODE N.	Ø	MORSE	D
114-33208	32	1	12,065
114-33209	32	2	17,780

BUSSOLA PER PORTABARENI BORING BAR SLEEVE FOR TOOLHOLDER

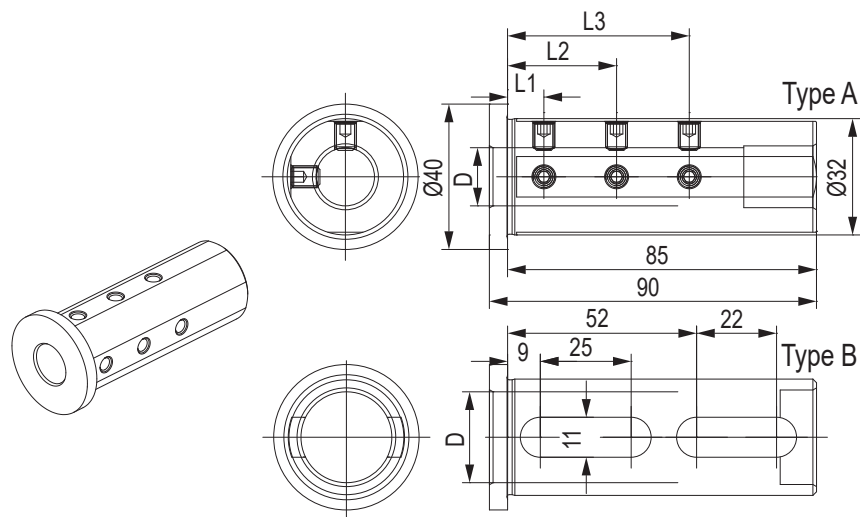

CODE N.	Ø	D	L1	L2	L3	TYPE	SCREW
115-63260	25	8	8	35	-	A	811-102019
115-63261	25	10	8	40	-	A	811-102019
115-63211	25	12	8	40	-	A	811-102018
115-63212	25	16	10	30	50	A	811-102018
115-63213	25	20	10	30	50	A	811-102017
115-63214	25	25	-	-	-	B	-

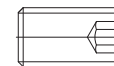

BUSSOLA PER PORTABARENI BORING BAR SLEEVE FOR TOOLHOLDER

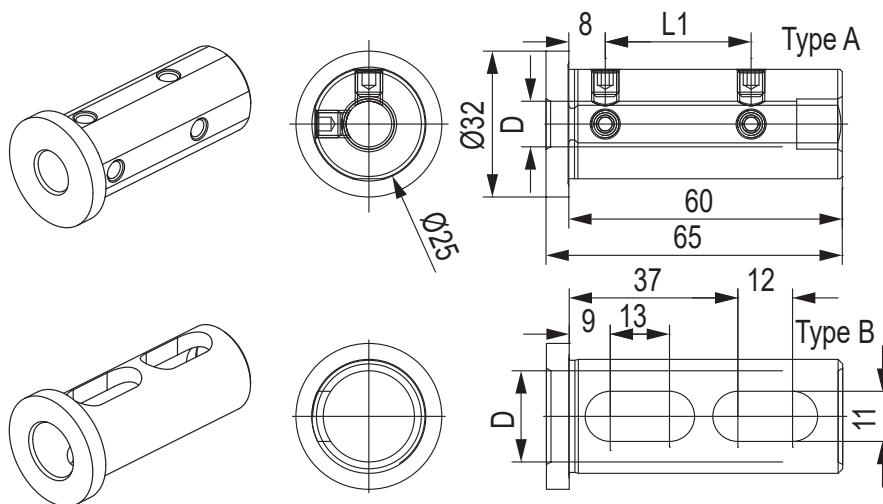

CODE N.	Ø	D	L1	TYPE	SCREW
115-62538	25	8	27	A	811-102018
115-62539	25	10	32	A	811-102017
115-62540	25	12	32	A	811-102017
115-62541	25	16	-	B	-

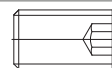

BUSSOLA PER PORTABARENI BORING BAR SLEEVE FOR TOOLHOLDER

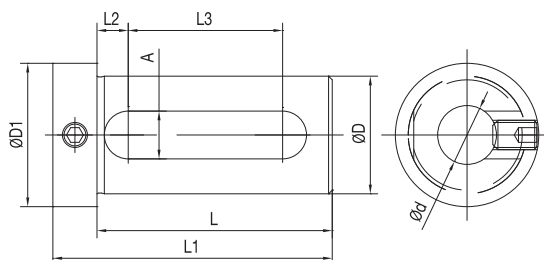

CODE N.	D	d	L	L1	L2	L3	A	D1
115-62044	20	8	50	60	7	29	11	28
115-62045	20	10	50	60	7	29	11	28
115-62046	20	12	50	60	7	29	11	28
115-62047	20	16	50	60	7	29	11	28
165-62545	25	12	55	67	8	32	13	33
165-62547	25	16	55	67	8	32	13	33
165-62549	25	20	55	67	8	32	13	33
165-63347	32	16	65	77	8	42	13	39
165-63349	32	20	65	77	8	42	13	39
165-63350	32	25	65	77	8	42	13	39
165-64241	40	16	75	89	9	51	14	48
165-64243	40	20	75	89	9	51	14	48
165-64244	40	25	75	89	9	51	14	48
165-64245	40	32	75	89	9	51	14	48
165-65017	50	25	85	99	9	61	14	60
165-65018	50	32	85	99	9	61	14	60
165-65019	50	40	85	99	9	61	14	60
165-66056	60	25	95	109	9	71	14	70
165-66057	60	32	95	109	9	71	14	70
165-66058	60	40	95	109	9	71	14	70
165-66059	60	50	95	109	9	71	14	70

BUSSOLA PER PORTABARENI BORING BAR SLEEVE FOR TOOLHOLDER

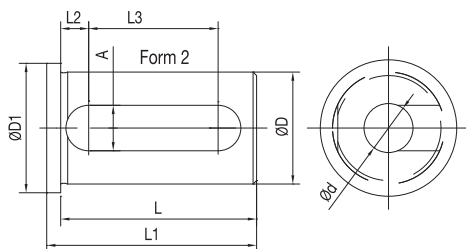
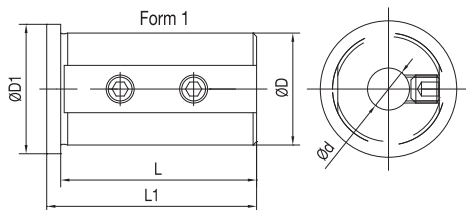

CODE N.	D	d	FORM	L	L1	L2	L3	A	D1
165-62551	25	8	1	46	50	-	-	-	30
165-62552	25	10	1	46	50	-	-	-	30
165-62553	25	12	1	46	50	-	-	-	30
165-62555	25	16	2	46	50	8	27	13	30
165-62557	25	20	2	46	50	8	27	13	30
165-63352	32	8	1	56	60	-	-	-	37
165-63353	32	10	1	56	60	-	-	-	37
165-63354	32	12	1	56	60	-	-	-	37
165-63356	32	16	2	56	60	8	37	13	37
165-63358	32	20	2	56	60	8	37	13	37
165-63359	32	25	2	56	60	8	37	13	37
165-64247	40	8	1	71	75	-	-	-	45
165-64248	40	10	1	71	75	-	-	-	45
165-64249	40	12	1	71	75	-	-	-	45
165-64251	40	16	2	71	75	8	52	13	45
165-64253	40	20	2	71	75	8	52	13	45
165-64254	40	25	2	71	75	8	52	13	45
165-64255	40	32	2	71	75	8	52	13	45



DOOSAN
(BMT55)

LYNX 300 (M)
PUMA 1500/2000/2500 (M,S,Y)
PUMA 2100 (Y,LY,SY,LSY)
PUMA 2100/2600/3100 M/Y/MS/SY
PUMA 230/240/280 (M,LM,S)
PUMA GT2100M / PUMA H250TM
PUMA H250TM
PUMA MX2100 (ST/LST)
PUMA TL2000/2500 (M,LM)
PUMA TT1500/1800 (MS,SY)

SAMSUNG
HARDINGE
HYUNDAI WIA

HWACHEON
VICTOR

PL 240LM
T-51 / 65 super precision H51
WIA L230 LMSA
SKT-160 / 180 TTMS / TTSY
LM 1600 / 1800 TTSY
CUTEX-160 / 240 / T2
VTURN-A16/A20 (YSCM)

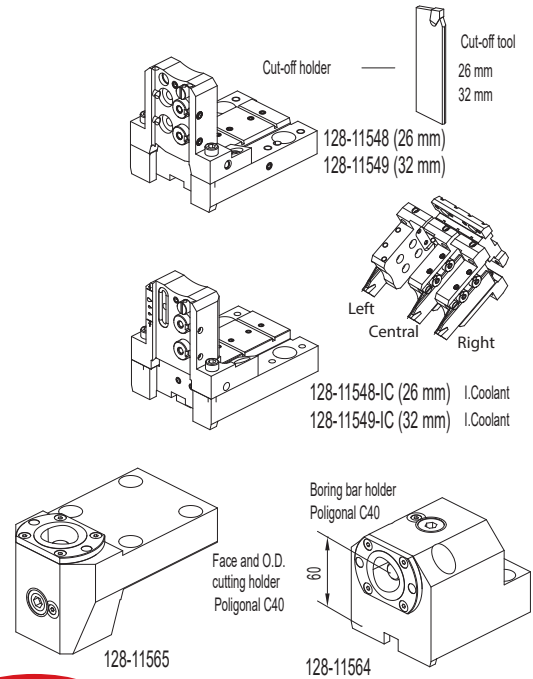
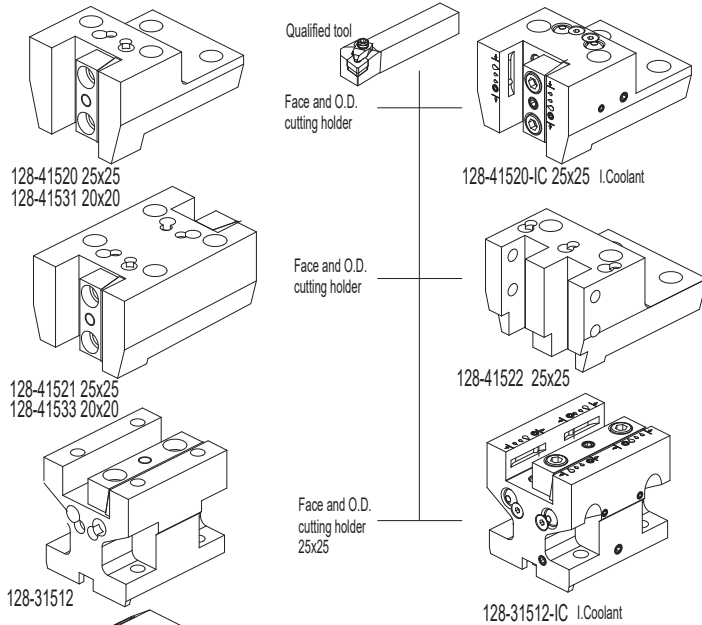

NEWS

ACCESSORIES

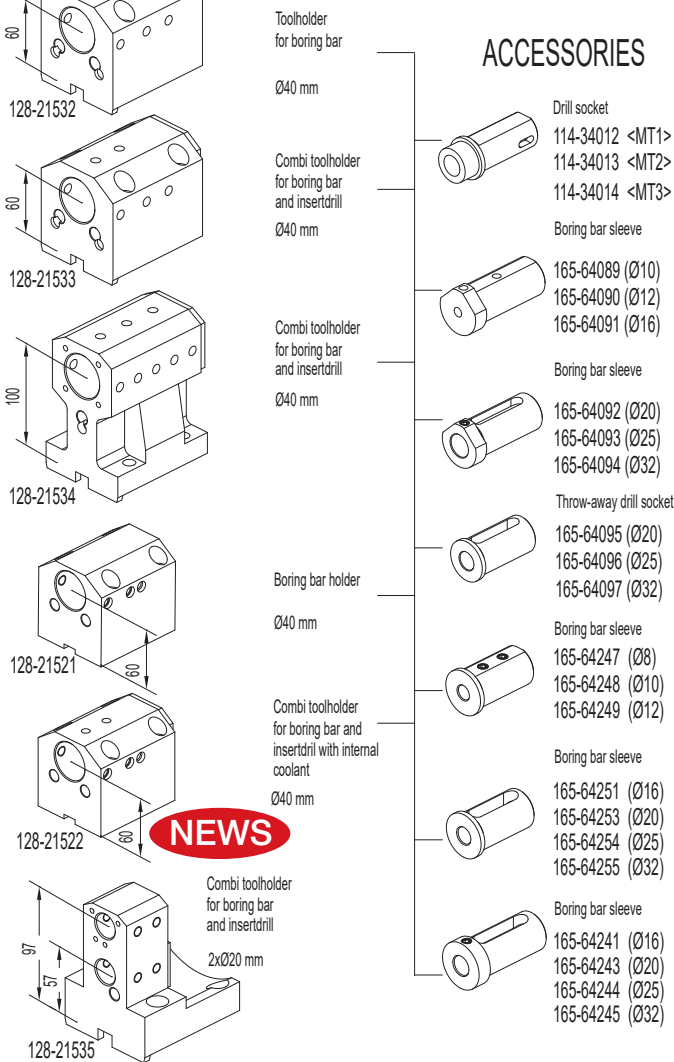

Driven tools

FAST-IN



CONNECTION

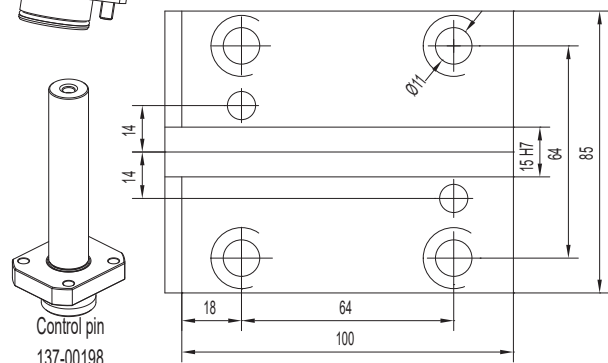

CONNECTION

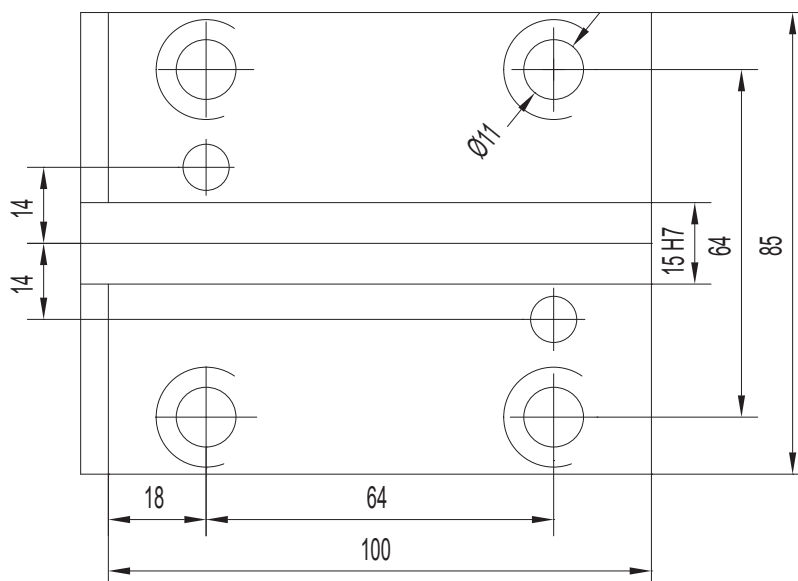

PORTAUTENSILE RADIALE - RADIAL TOOLHOLDERS

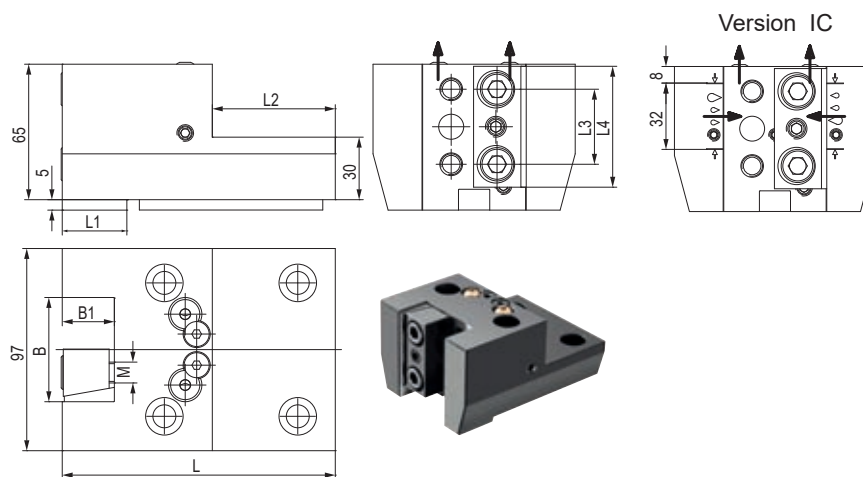

CODE N.	B	B1	L	L1	L2	L3	L4	M
128-41520	50	25	131	31	59	36	58	M10
128-41520-IC	50	25	131	31	59	36	58	M10
128-41531	40	20	109	9	50	35	58	M8

CODE N.	INTERNAL COOLANT	CLAMPING PLATE	KEY	SCREW FOR KEY	COOLANT BALL	SCREW FOR BALL
128-41520	NO	832-007570	814-203230	811-101016	833-001470	811-108018
128-41520-IC	YES	832-007570	814-203230	811-101016	833-001470	811-108018
128-41531	NO	832-007160	814-203230	811-101016	833-001470	811-108018

PORTAUTENSILE RADIALE - RADIAL TOOLHOLDERS

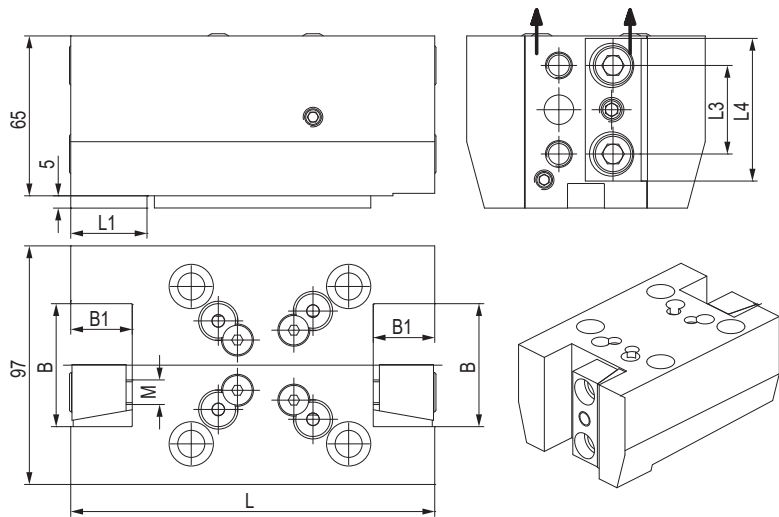

CODE N.	B	B1	L	L1	L3	L4	M
128-41521	50	25	148	31	36	58	M10
128-41533	40	20	122	9	35	58	M8

CODE N.	CLAMPING PLATE	KEY	SCREW FOR KEY	COOLANT BALL	SCREW FOR BALL
128-41521	832-007570	814-203230	811-101016	833-001470	811-108018
128-41533	832-007160	814-203450	811-101016	833-001470	811-108018

PORTAUTENSILE RADIALE - RADIAL TOOLHOLDERS

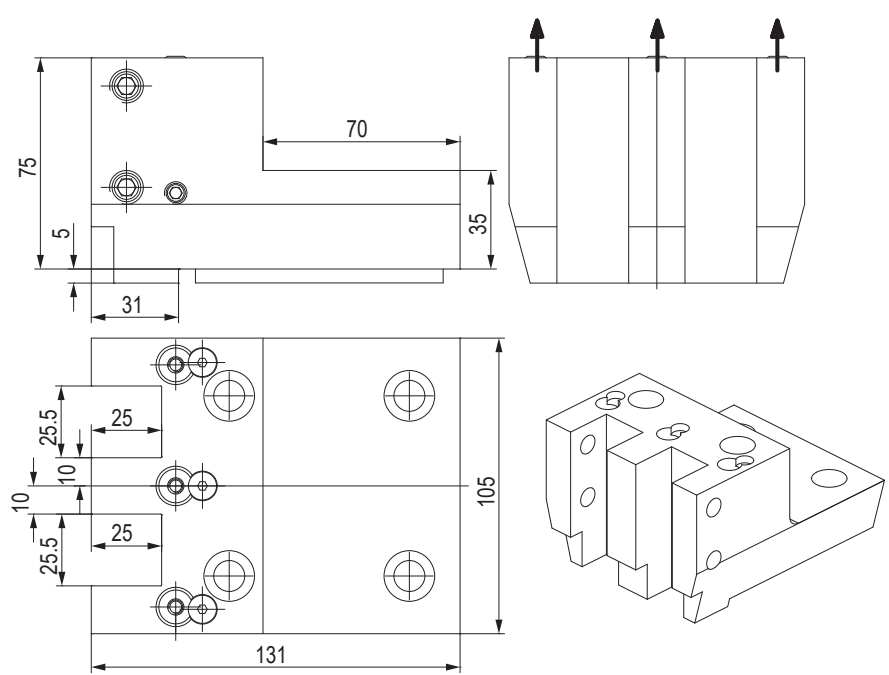

CODE N.	CLAMPING SCREW	KEY	SCREW FOR KEY	COOLANT BALL	SCREW FOR BALL
128-41522	811-102043	814-203230	811-101016	833-001410	811-108024

PORTAUTENSILE ASSIALE - AXIAL TOOLHOLDERS

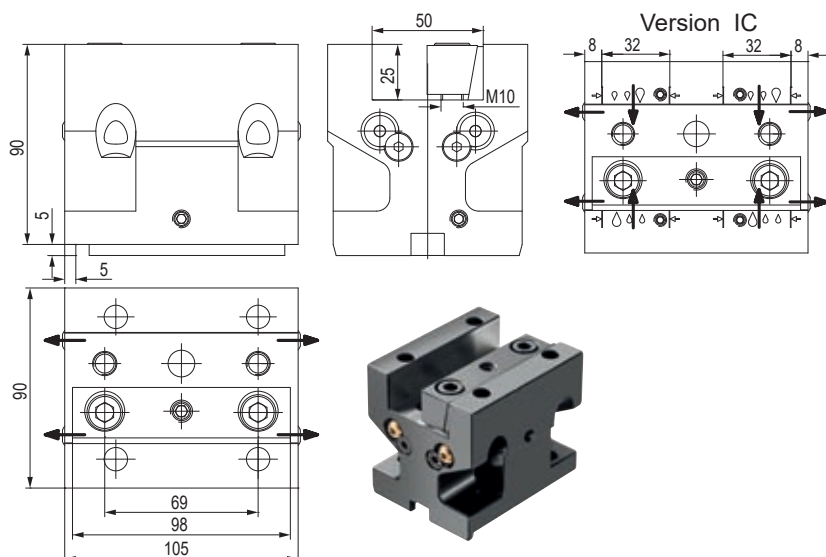

CODE N.	INTERNAL COOLANT	CLAMPING PLATE	KEY	SCREW FOR KEY	COOLANT BALL	SCREW FOR BALL
128-31512	NO	832-007220	814-203230	811-101016	833-001470	811-108018
128-31512-IC	YES	832-007220	814-203230	811-101016	833-001470	811-108018

PORTALAMA - CUT-OFF HOLDERS

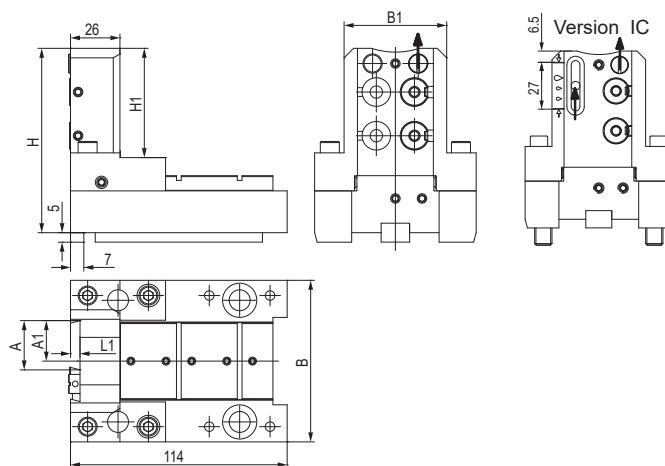
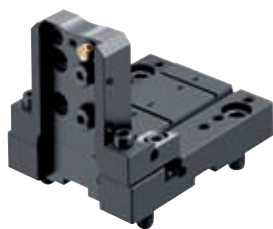
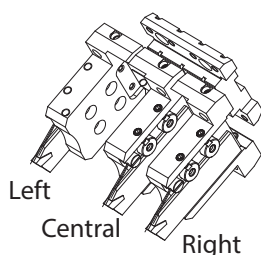

CODE N.	A	A1	B	B1	H	H1	L1
128-11548	26	21.4	85	54	97	57.5	5
128-11548-IC	26	21.4	85	54	97	57.5	5
128-11549	32	25	94	63	105	66	6
128-11549-IC	32	25	94	63	105	66	6

CODE N.	INTERNAL COOLANT	KEY	SCREW FOR KEY	COOLANT NOZZLE	O RING FOR COOLANT NOZZLE	O RING FOR INT. COOLANT	O RING FOR BODY
128-11548	NO	814-203230	811-101015	833-001490	823-101058	-	823-101061
128-11548-IC	YES	814-203230	811-101015	833-001490	823-101058	823-201140	823-101061
128-11549	NO	814-203230	811-101015	833-001490	823-101058	-	823-101061
128-11549-IC	YES	814-203230	811-101015	833-001490	823-101058	823-201140	823-101061

CODE N.	SHIM PLATE	SCREW FOR PLATE	CLAMPING PIN	SPRING	CLAMPING SCREW	SCREW
128-11548	832-014448	811-108037	832-014447	824-300012	811-101028	811-104013
128-11548-IC	832-014448	811-108037	832-014447	824-300012	811-101028	811-104013
128-11549	832-014448	811-108037	832-014450	824-300012	811-101029	811-104013
128-11549-IC	832-014448	811-108037	832-014450	824-300012	811-101029	811-104013

PORTAUTENSILE PER BARENI - TOOLHOLDER FOR BORING BAR

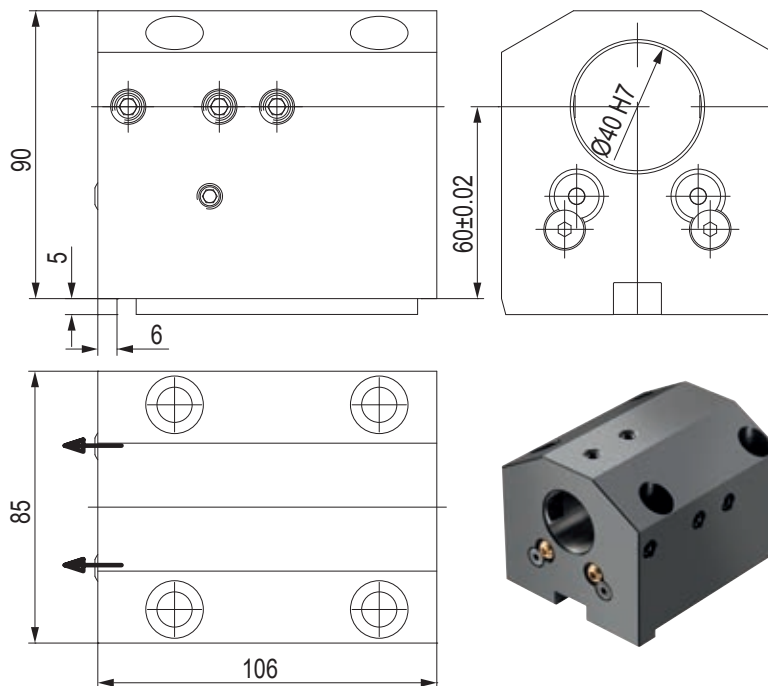

CODE N.	CLAMPING SCREW	KEY	SCREW FOR KEY	COOLANT BALL	SCREW FOR BALL
128-21532	811-102038	814-203230	811-101016	833-001470	811-108018

PORTAUTENSILE COMBINATO PER BARENI E PUNTE A INSERTI COMBI TOOLHOLDER FOR BORING BAR AND INSERTDRILL

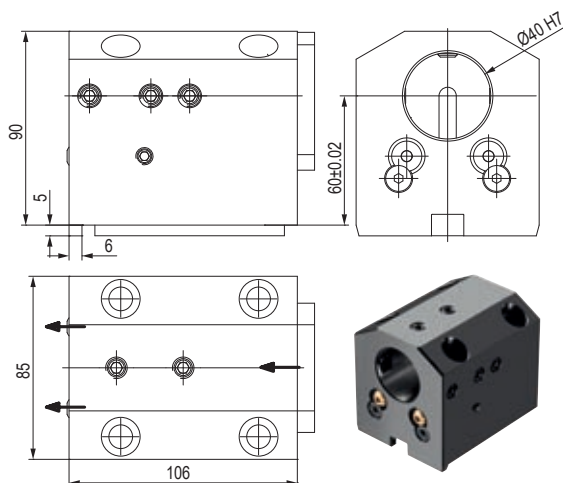

CODE N.	CLAMPING SCREW1 (M10X20)	CLAMPING SCREW2 (M10X12)	KEY	SCREW FOR KEY
128-21533	811-102038	811-102036	814-203230	811-101016

CODE N.	COOLANT BALL	SCREW FOR BALL	COVER	SCREW FOR COVER
128-21533	833-001470	811-108018	832-003363	811-101016

PORTAUTENSILE COMBINATO PER BARENI E PUNTE A INSERTI COMBI TOOLHOLDER FOR BORING BAR AND INSERTDRILL

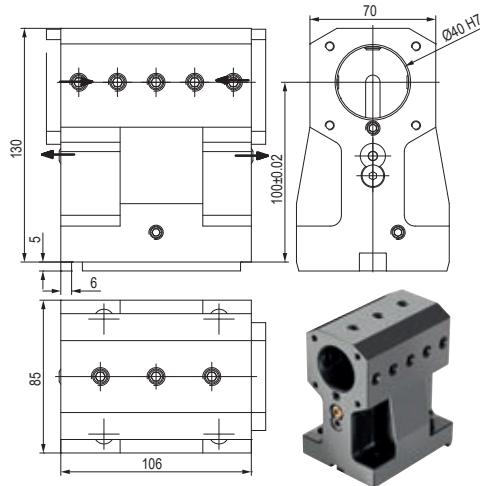

CODE N.	CLAMPING SCREW1 (M10X16)	CLAMPING SCREW2 (M10X12)	KEY	SCREW FOR KEY
128-21534	811-102037	811-102036	814-203230	811-101016

CODE N.	COOLANT BALL	SCREW FOR BALL	COVER	SCREW FOR COVER
128-21534	833-001470	811-108018	832-003363	811-101016

PORTAUTENSILE COMBINATO PER BARENI E PUNTE A INSERTI COMBI TOOLHOLDER FOR BORING BAR AND INSERTDRILL

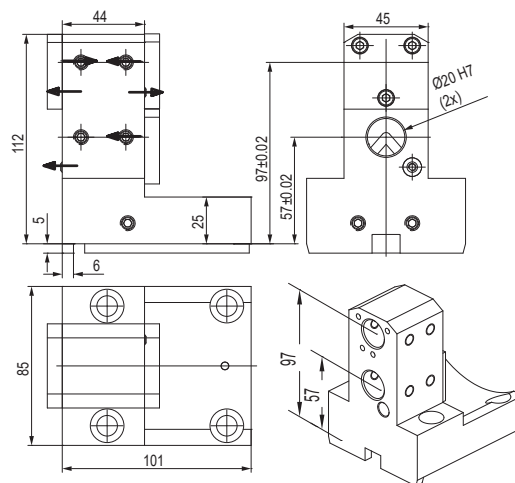

CODE N.	CLAMPING SCREW	KEY	SCREW FOR KEY
128-21535	811-102028	814-203230	811-101016

CODE N.	COOLANT NOZZLE	COVER	SCREW FOR COVER
128-21535	833-001070	832-003368	811-101016

PORTAUTENSILE PER BARENI - TOOLHOLDER FOR BORING BAR

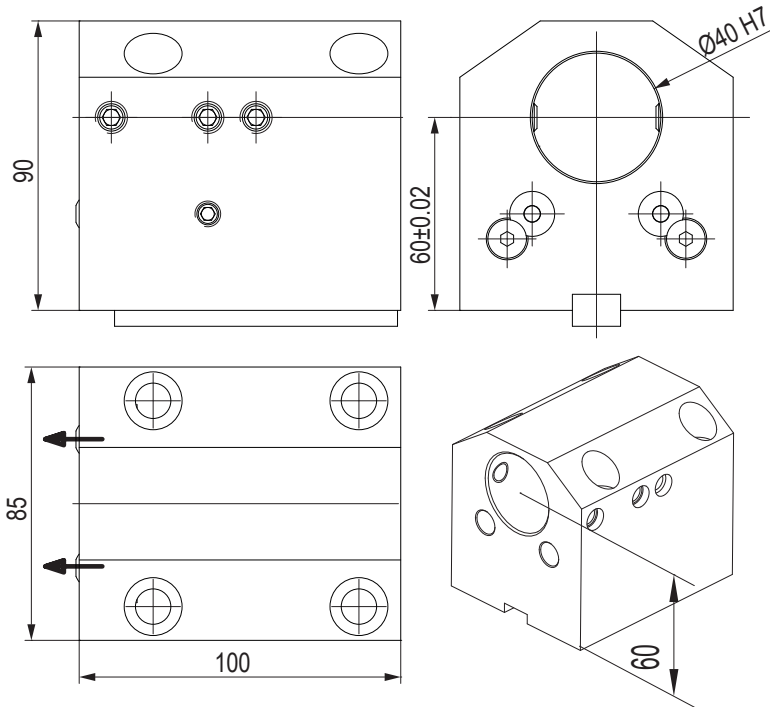

CODE N.	CLAMPING SCREW	KEY	SCREW FOR KEY	COOLANT BALL	SCREW FOR BALL
128-21521	811-102038	814-203230	811-101017	833-001470	811-108018

PORTAUTENSILE COMBINATO PER BARENI E PUNTE A INSERTI COMBI TOOLHOLDER FOR BORING BAR AND INSERTDRILL

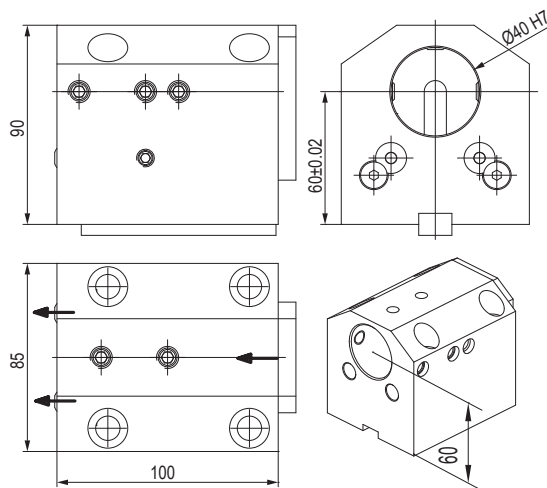

CODE N.	CLAMPING SCREW1 (M10X20)	CLAMPING SCREW2 (M10X10)	KEY	SCREW FOR KEY
128-21522	811-102038	811-102035	814-203230	811-101017

CODE N.	COOLANT BALL	SCREW FOR BALL	COVER	CODE N.
128-21522	833-001470	811-108018	832-003216	811-101017

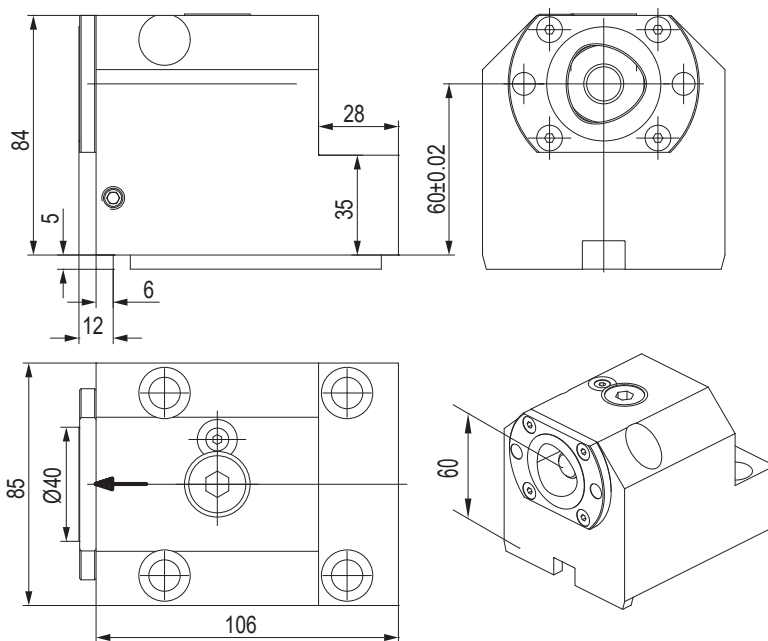

PORTAUTENSILE CON USCITA POLIGONALE POLIGONAL TOOLHOLDERS

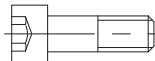

CODE N.	CAPTO	CLAMPING UNIT	KEY	SCREW FOR KEY
128-11564	C40	CXC40-10		
			814-203230	811-101016

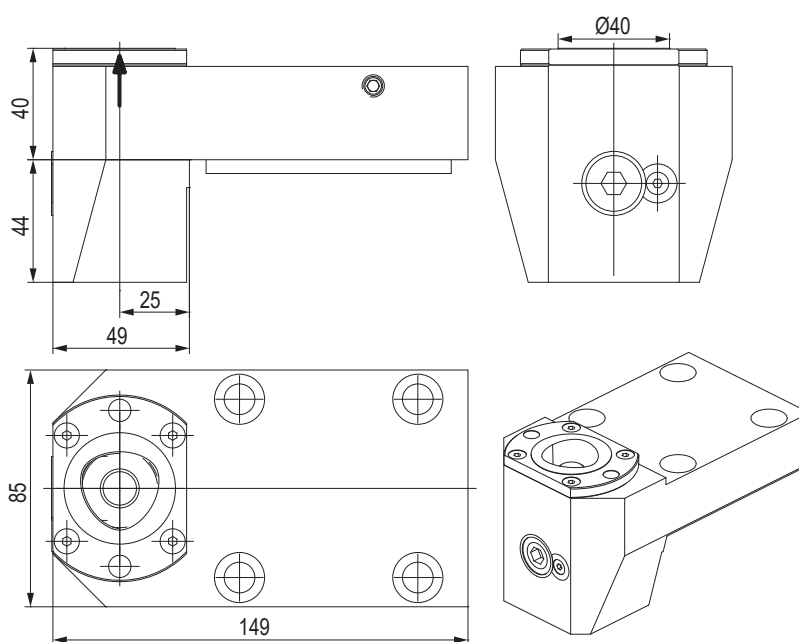
PORTAUTENSILE CON USCITA POLIGONALE POLIGONAL TOOLHOLDERS



CODE N.	CAPTO	CLAMPING UNIT	KEY	SCREW FOR KEY
128-11565	C40	CXC40-10		
			814-203230	811-101016

PORTAUTENSILE MOTORIZZATO ASSIALE STRAIGHT DRILLING AND MILLING HEAD

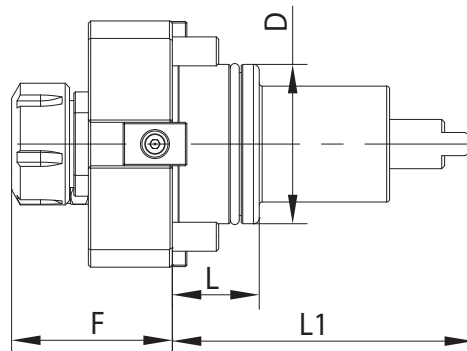
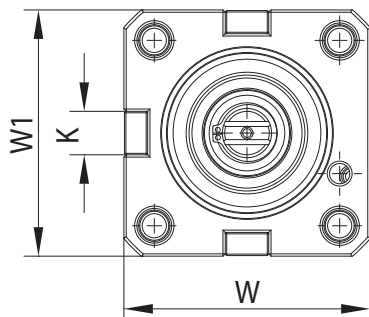

CODE N.	ER	D	F	K	L	L1	W	W1	MAX SPEED (Rpm)	I	MAX. TORQUE (Nm)	INTERNAL COOLING
124-05501	ER25	55	71	15	30	104	85	85	6000	1:1	50	no
124-06509	ER25	55	71	15	30	104	85	85	6000	1:1	50	yes

PORTAUTENSILE MOTORIZZATO RADIALE ANGULAR DRILLING AND MILLING HEAD

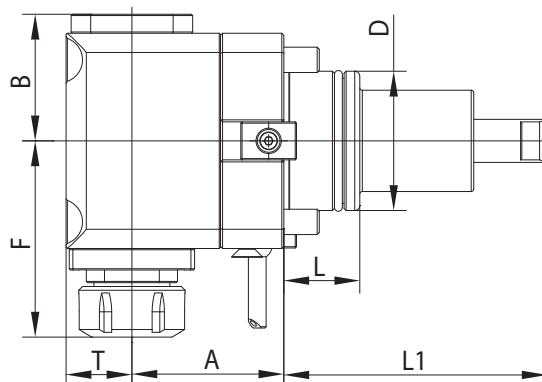
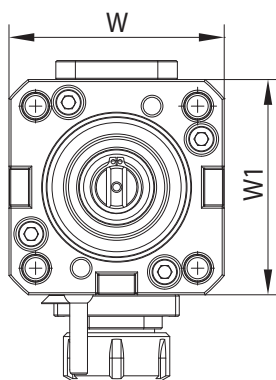

CODE N.	ER	D	A	B	F	L	L1	T	W	W1	MAX SPEED (Rpm)	I	MAX. TORQUE (Nm)	INTERNAL COOLING	P BAR
124-05502	ER25	55	70	57	86	30	104	26	85	85	6000	1:1	25	no	-
124-06510	ER25	55	70	57	86	30	104	26	85	85	6000	1:1	25	yes	20

BARRA DI CONTROLLO - CONTROL PIN

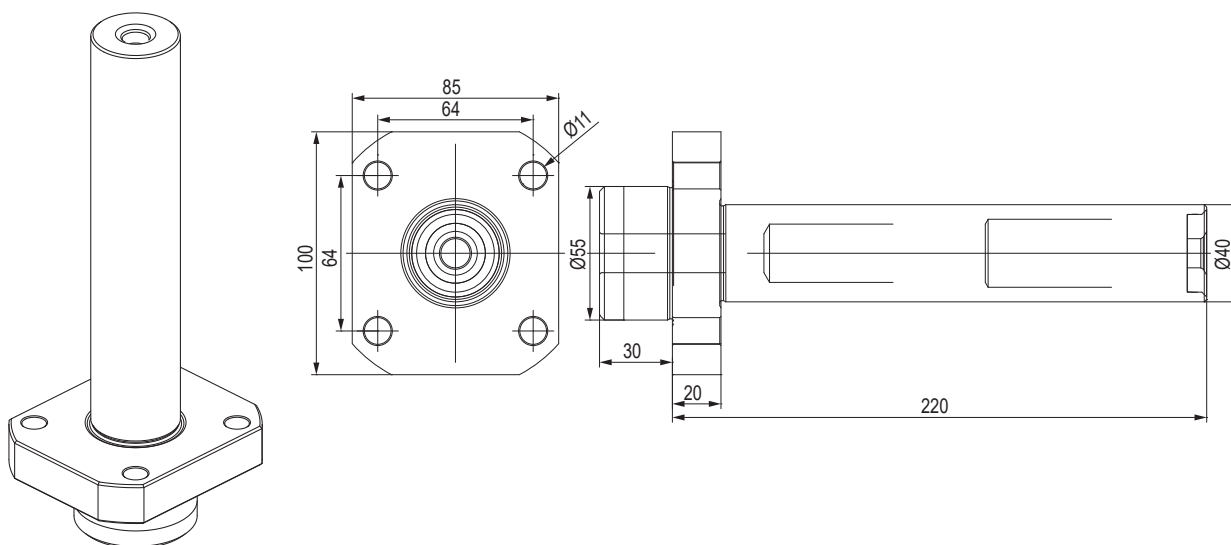

CODE N.

137-00198

TAPPO DI PROTEZIONE - PROTECTION COVER

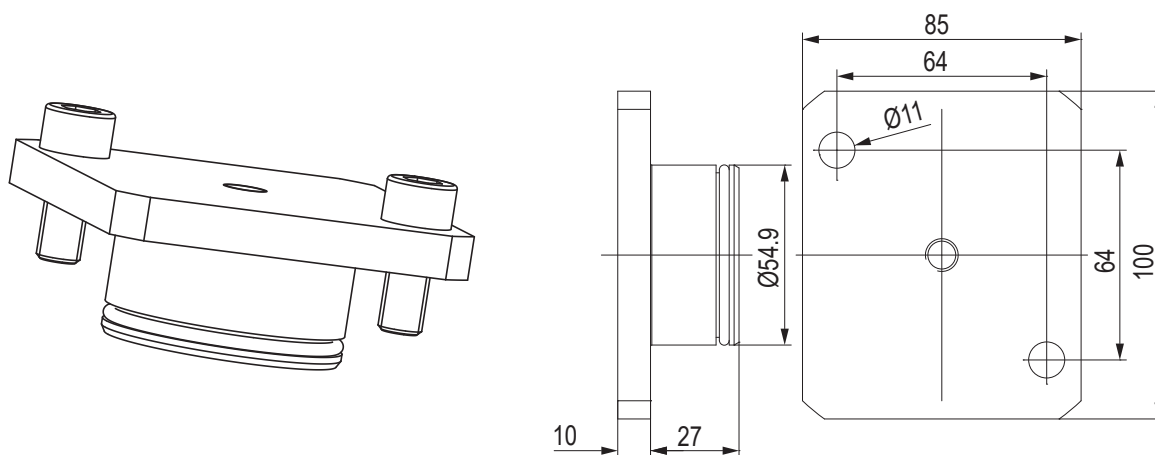

CODE N.

O RING



137-00253

823-101064

12

KINTEK®

BUSSOLA PER PORTABARENI DRILL SOCKET FOR TOOLHOLDER

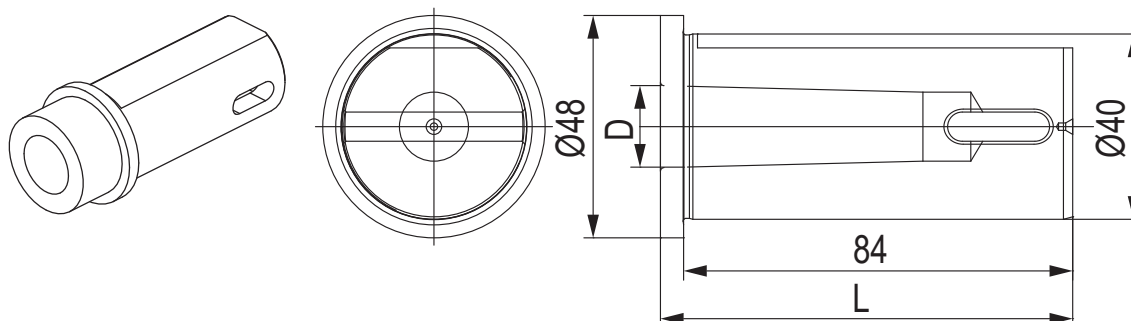

CODE N.	Ø	MORSE	D	L
114-34012	40	1	12,065	89
114-34013	40	2	17,780	89
114-34014	40	3	23,825	110

BUSSOLA PER PORTABARENI BORING BAR SLEEVE FOR TOOLHOLDER

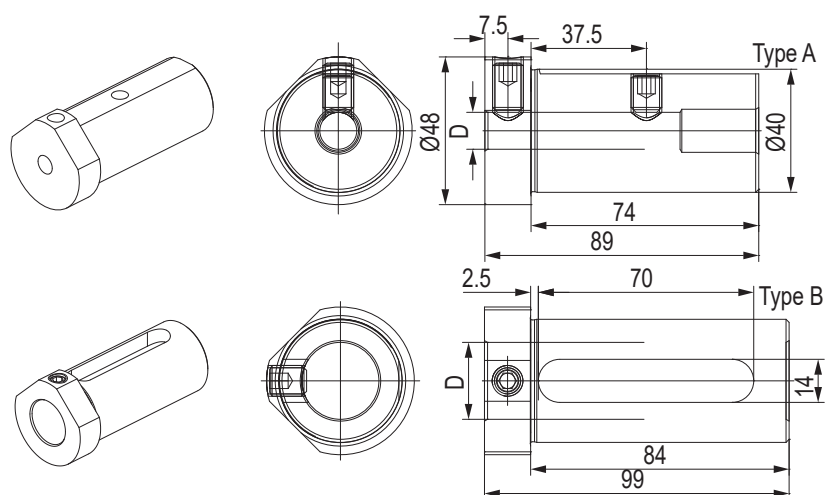

CODE N.	Ø	D	TYPE	SCREW1	SCREW2
165-64089	40	10	A	811-102037	811-102036
165-64090	40	12	A	811-102037	811-102036
165-64091	40	16	A	811-102037	811-102035
165-64092	40	20	B	811-102036	-
165-64093	40	25	B	811-102036	-
165-64094	40	32	B	811-102035	-

BUSSOLA PER PORTABARENI BORING BAR SLEEVE FOR TOOLHOLDER

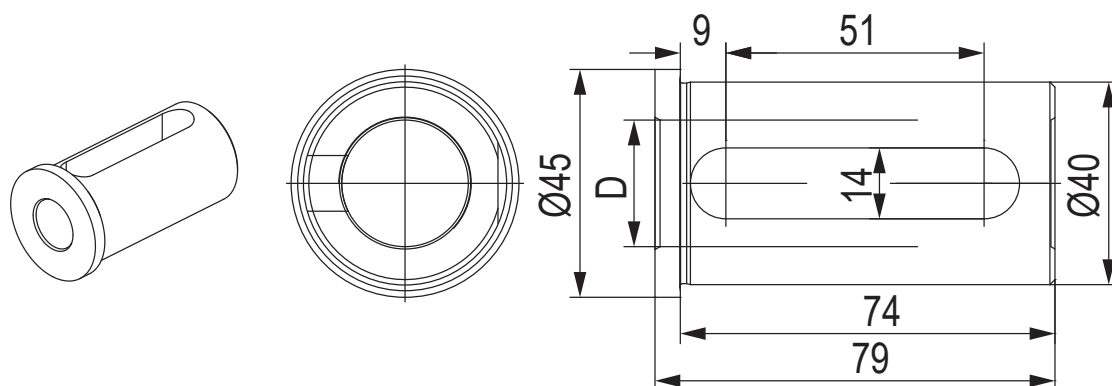

CODE N.	Ø	D
165-64095	40	20
165-64096	40	25
165-64097	40	32

BUSSOLA PER PORTABARENI BORING BAR SLEEVE FOR TOOLHOLDER

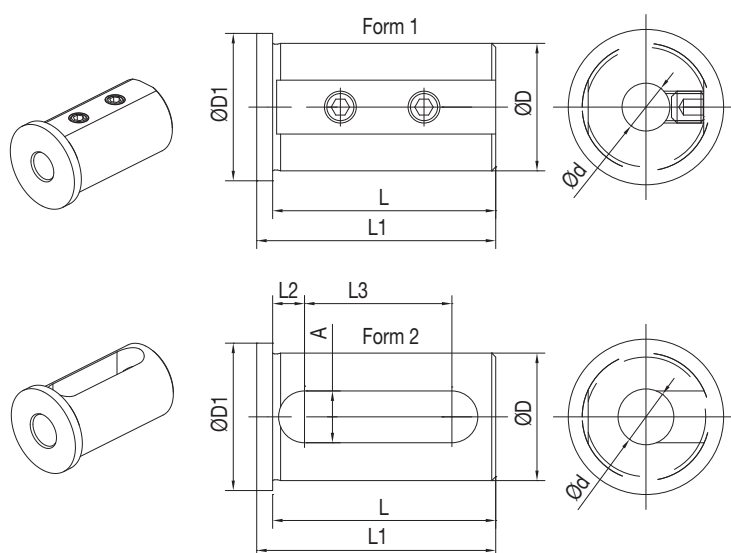

CODE N.	D	d	FORM	L	L1	L2	L3	A	D1
165-64247	40	8	1	71	75	-	-	-	45
165-64248	40	10	1	71	75	-	-	-	45
165-64249	40	12	1	71	75	-	-	-	45
165-64251	40	16	2	71	75	8	52	13	45
165-64253	40	20	2	71	75	8	52	13	45
165-64254	40	25	2	71	75	8	52	13	45
165-64255	40	32	2	71	75	8	52	13	45

BUSSOLA PER PORTABARENI BORING BAR SLEEVE FOR TOOLHOLDER

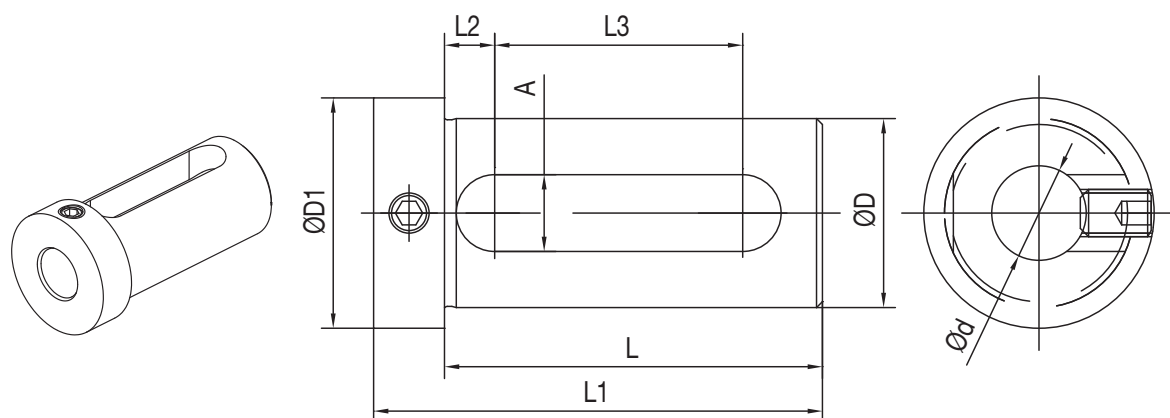

CODE N.	D	d	L	L1	L2	L3	A	D1
165-64241	40	16	74	88	9	51	14	48
165-64243	40	20	74	88	9	51	14	48
165-64244	40	25	74	88	9	51	14	48
165-64245	40	32	74	88	9	51	14	48



DOOSAN PUMA (BMT65)

PUMA 2100/2600 (M,LM,MS,LMS)
PUMA 2100/2600 (Y,LY,SY,LSY)
PUMA 300 (M,MS,MB,MC)
PUMA 3100 (M,LM,LY,XLM,XLY,ULM,ULY)
PUMA MX2000/2500
PUMA MX2600 (T,ST)
PUMA TT2500 (MS/SY)
PUMA V400 (M)
PUMA VT450 (M,2SP)
PUMA TT2000

HWACHEON
CUTEX-240
HI-TECH200/T2-Series
HI-TECH300/400
VT-450

HYUNDAI WIA
L2100SY
SKT-200/250TTSY
SKT-250/300 (L,M)
SKT-250/300 (MS)
L300M / MS
LM 2000 / 2500 TTM
2500 TTMS / 2500 TTSY

MAXSIN
BMT65
SMEC/SAMSUNG
SL25 / SL35
PL 20/25M - PL 35LM - PL 2000/2500Y

TONGTAI
TMT2000

VICTOR
VTURN-A26 (YSCM)

HAAS
ST-20 - ST-25 - ST-30
ST-35 - DS-30Y
ST-20Y - ST-25Y - ST-30Y - ST-35Y

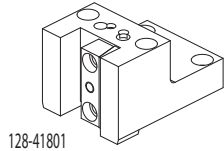

128-41801

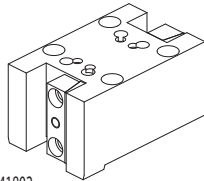

128-41802

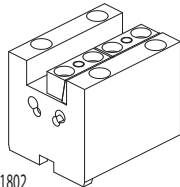

128-31802

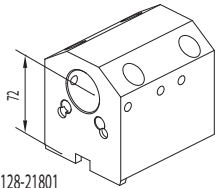

128-21801

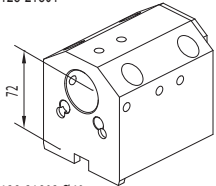

128-21802 Ø40
128-21805 Ø50

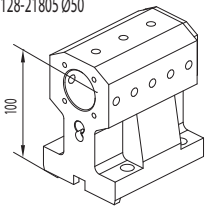

128-21803 Ø40
128-21806 Ø50

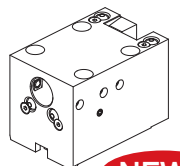

128-11821 Ø32/25x25

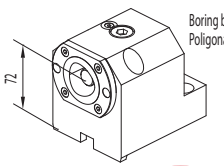

128-11817 (C40)
128-11805 (C50)

Face and O.D.
cutting holder

Face and O.D.
cutting holder

Face and O.D.
cutting holder

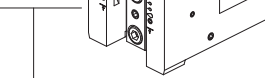

128-41801-IC I.Coolant

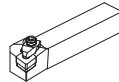

Qualified tool
25x25 mm

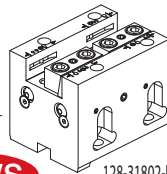

128-31802-IC

NEWS

Face and O.D.
cutting holder

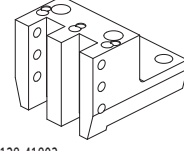

128-41803

Face and O.D.
cutting holder

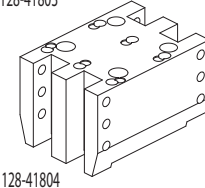

128-41804

Face and O.D.
cutting holder
Polygonal

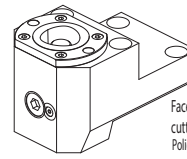

128-11819 (C40)
128-11809 (C50)

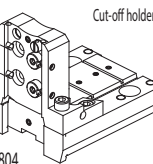

128-11804

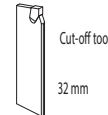

Cut-off tool
32 mm

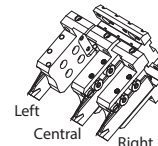

Left
Central
Right

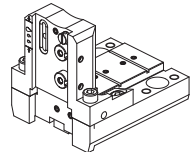

128-11804-IC I.Coolant

ACCESSORIES

Drill socket D40

114-34012 <MT1>
114-34013 <MT2>
114-34014 <MT3>

Boring bar sleeve D40

165-64089 (Ø10)
165-64090 (Ø12)
165-64091 (Ø16)

Boring bar sleeve D40

165-64092 (Ø20)
165-64093 (Ø25)
165-64094 (Ø32)

Throw-away drill socket D40

165-64095 (Ø20)
165-64096 (Ø25)
165-64097 (Ø32)

Boring bar sleeve D40

165-64247 (Ø8)
165-64248 (Ø10)
165-64249 (Ø12)

Boring bar sleeve D40

165-64251 (Ø16)
165-64253 (Ø20)
165-64254 (Ø25)
165-64255 (Ø32)

Boring bar sleeve D40

165-64241 (Ø16)
165-64243 (Ø20)
165-64244 (Ø25)
165-64245 (Ø32)

Boring bar sleeve D50

165-65017 (Ø25)
165-65018 (Ø32)
165-65019 (Ø40)

Boring bar holder double
Polygonal

128-11818 (C40)
128-11807 (C50)

NEWS

NEWS

Driven tools



124-06501
124-06508 I.Coolant



124-06502
124-06512 I.Coolant

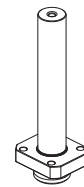

Control pin
137-00199



Protection cover
137-00254

FAST-IN



CONNECTION

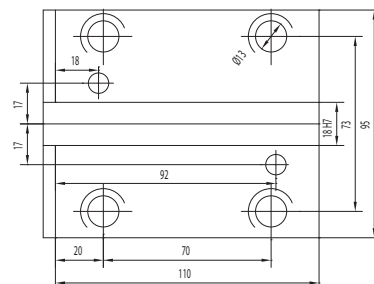



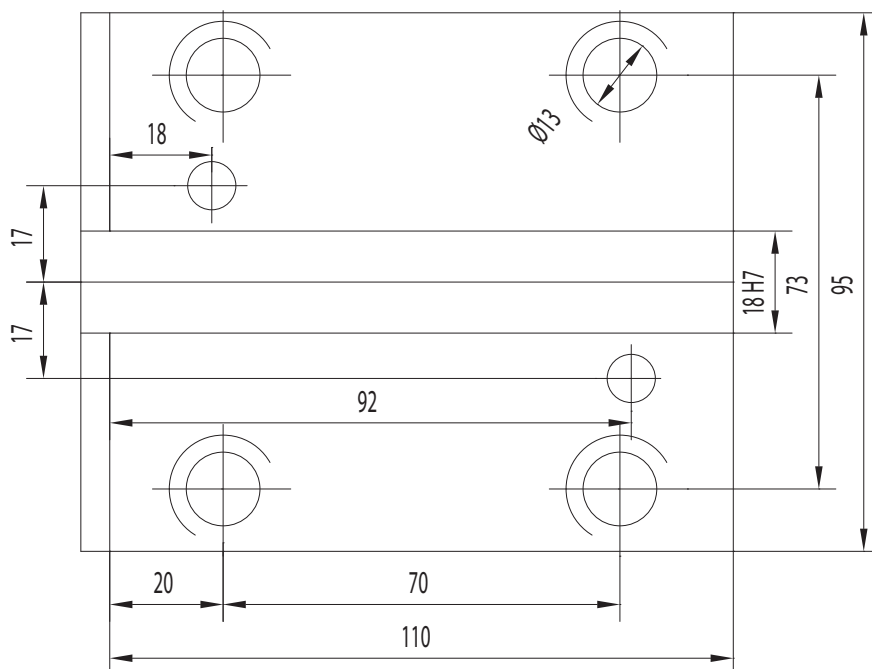

CONNECTION

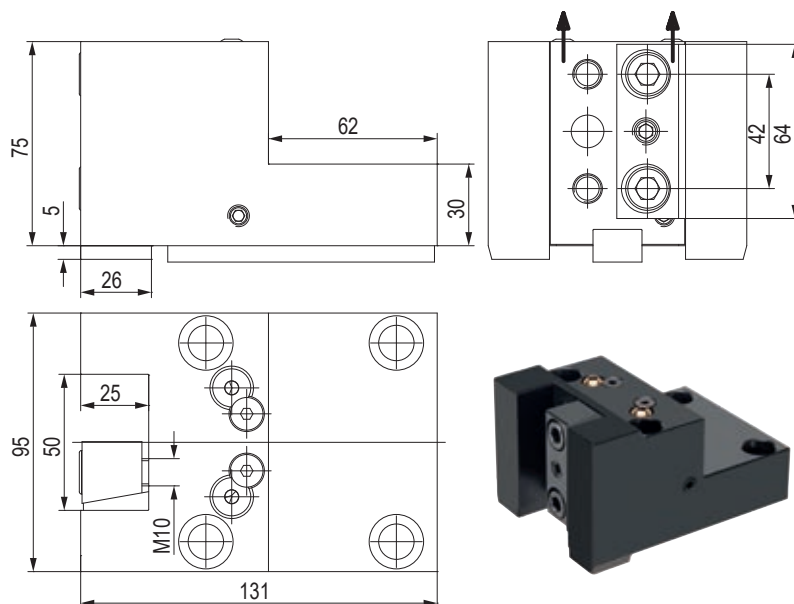

PORTAUTENSILE RADIALE - RADIAL TOOLHOLDERS



CODE N.	INTERNAL COOLANT	CLAMPING PLATE	KEY	SCREW FOR KEY	COOLANT BALL	SCREW FOR BALL
128-41801	NO					
128-41801-IC	YES	832-007360	814-203310	811-101027	833-001470	811-108018
		832-007360	814-203310	811-101027	833-001470	811-108018

PORTAUTENSILE RADIALE - RADIAL TOOLHOLDERS

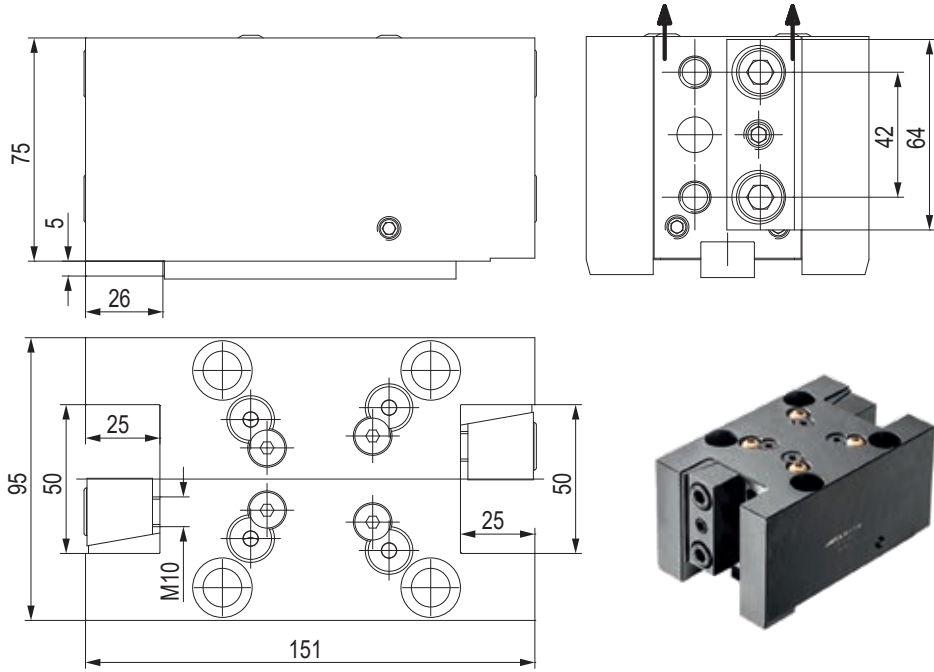

CODE N.	CLAMPING PLATE	KEY	SCREW FOR KEY	COOLANT BALL	SCREW FOR BALL
128-41802	832-007360	814-203310	811-101027	833-001470	811-108018

PORTAUTENSILE RADIALE - RADIAL TOOLHOLDERS

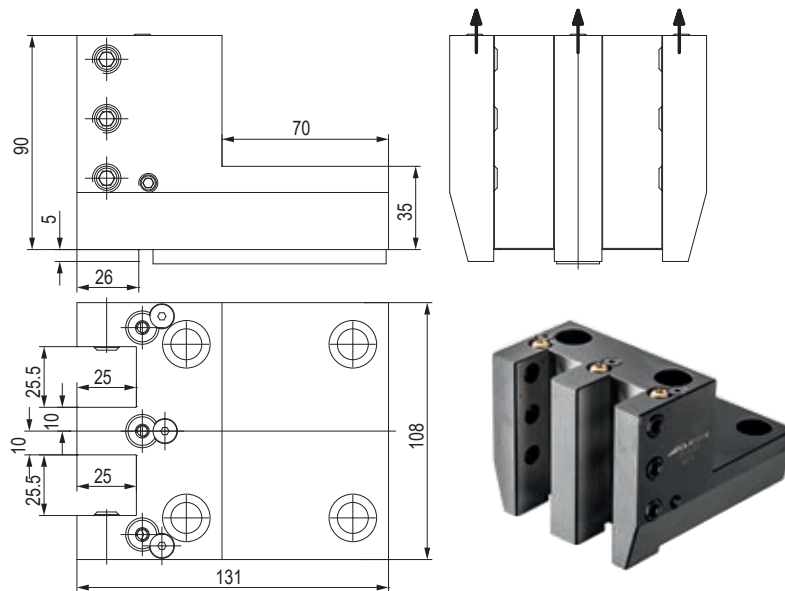

CODE N.	CLAMPING SCREW	KEY	SCREW FOR KEY	COOLANT BALL	SCREW FOR BALL
128-41803	811-102044	814-203310	811-101027	833-001410	811-108024

PORTAUTENSILE RADIALE - RADIAL TOOLHOLDERS

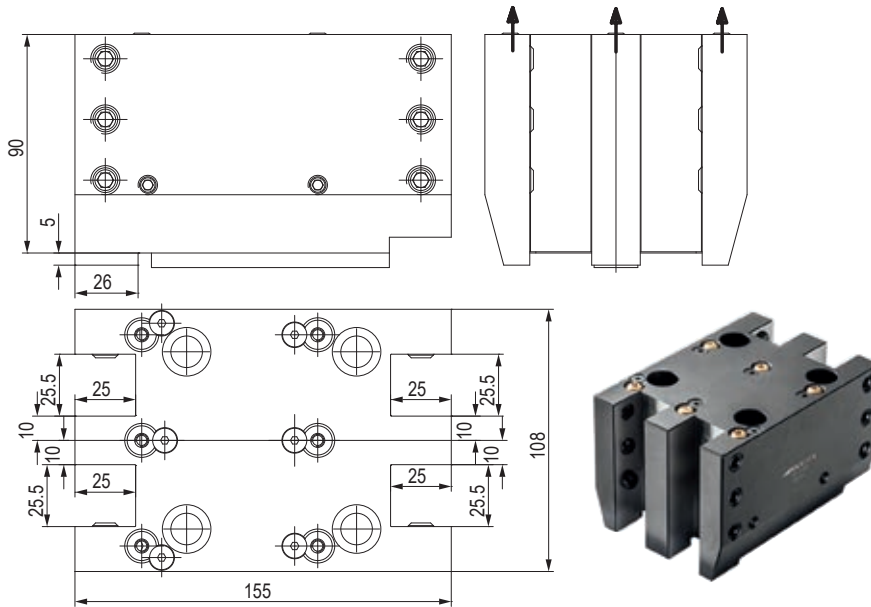

CODE N.	CLAMPING SCREW	KEY	SCREW FOR KEY	COOLANT BALL	SCREW FOR BALL
128-41804	811-102044	814-203310	811-101027	833-001410	811-108024

PORTAUTENSILE ASSIALE - AXIAL TOOLHOLDERS

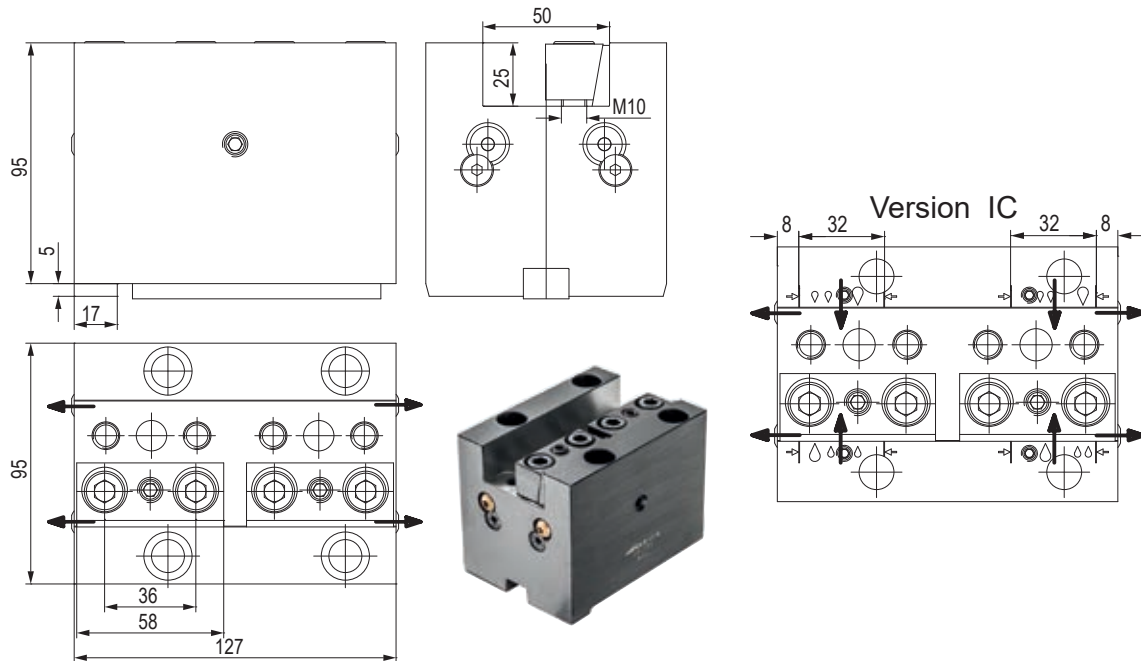

CODE N.	INTERNAL COOLANT	CLAMPING PLATE	KEY	SCREW FOR KEY	COOLANT BALL	SCREW FOR BALL
128-31802	NO	832-007570	814-203310	811-101027	833-001470	811-108018
128-31802-IC	YES	832-007570	814-203310	811-101027	833-001470	811-108018

PORTALAMA - CUT-OFF HOLDERS

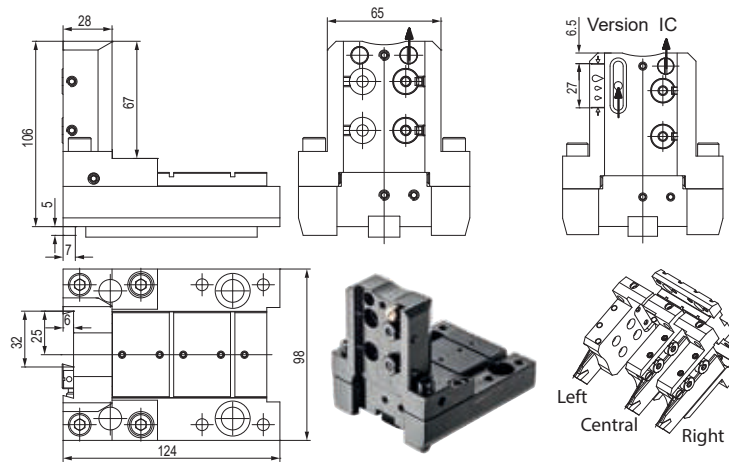

CODE N.	INTERNAL COOLANT	KEY	SCREW FOR KEY	COOLANT NOZZLE	O RING FOR COOLANT NOZZLE	O RING FOR INT. COOLANT	O RING FOR BODY
128-11804	NO	814-203310	811-101026	833-001490	823-101058	-	823-101061
128-11804-IC	YES	814-203310	811-101026	833-001490	823-101058	823-201140	823-101061

CODE N.	SHIM PLATE	SCREW FOR PLATE	CLAMPING PIN	SPRING	CLAMPING SCREW	SCREW
128-11804	832-014449	811-108037	832-014450	824-300012	811-101029	811-104013
128-11804-IC	832-014449	811-108037	832-014450	824-300012	811-101029	811-104013

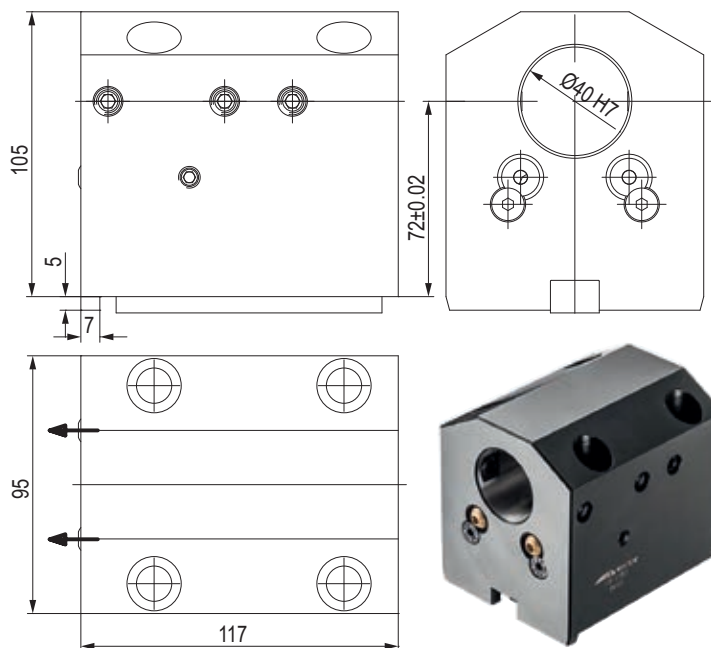

PORTAUTENSILE PER BARENI - TOOLHOLDER FOR BORING BAR



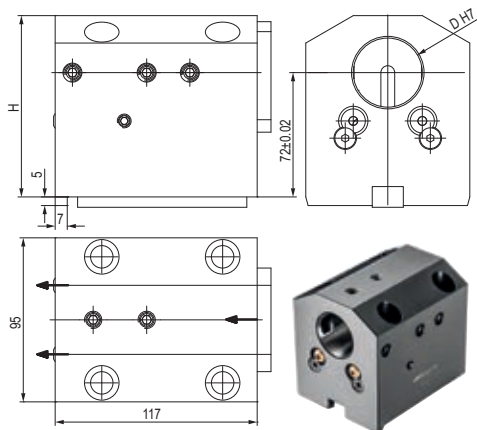

CODE N.	CLAMPING SCREW	KEY	SCREW FOR KEY	COOLANT BALL	SCREW FOR BALL
128-21801	811-102039	814-203310	811-101027	833-001470	811-108018

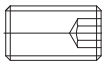
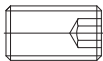
PORTAUTENSILE COMBINATO PER BARENI E PUNTE A INSERTI COMBI TOOLHOLDER FOR BORING BAR AND INSERTDRILL

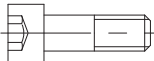

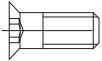

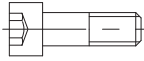

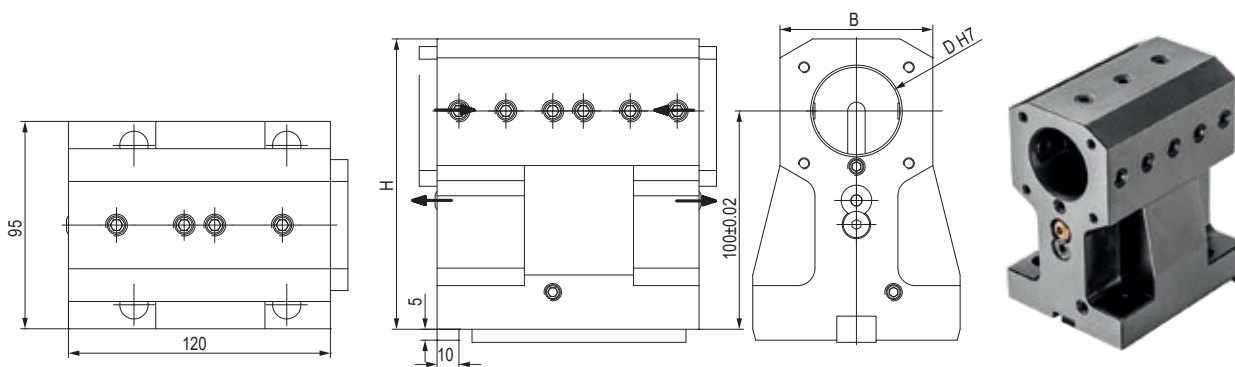

CODE N.	D	H	CLAMPING SCREW1 (M10X25 D40) - (M12X20 D50)	CLAMPING SCREW2 (M10X12 D40) - (M12X12 D50)	KEY	SCREW FOR KEY
						
128-21802	40	105	811-102039	811-102036	814-203310	811-101027
128-21805	50	109	811-102044	811-102064	814-203310	811-101027

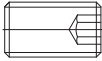
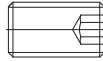
CODE N.	COOLANT BALL	SCREW FOR BALL	COVER	SCREW FOR COVER
				
128-21802	833-001470	811-108018	832-003363	811-101016
128-21805	833-001470	811-108018	832-003369	811-101016

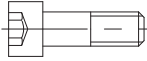
PORTAUTENSILE COMBINATO PER BARENI E PUNTE A INSERTI COMBI TOOLHOLDER FOR BORING BAR AND INSERTDRILL

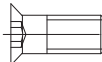

CODE N.	D	H	B	CLAMPING SCREW1 (M10X16 D40) - (M12X16 D50)	CLAMPING SCREW2 (M10X12 D40) - (M12X12 D50)	KEY	SCREW FOR KEY
							
128-21803	40	133	70	811-102037	811-102036	814-203310	811-101027
128-21806	50	137	80	811-102043	811-102064	814-203310	811-101027

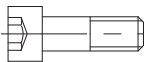
CODE N.	COOLANT BALL	SCREW FOR BALL	COVER	SCREW FOR COVER
				
128-21803	833-001470	811-108018	832-003363	811-101016
128-21806	833-001470	811-108018	832-003373	811-101016

PORTAUTENSILE COMBINATO PER BARENI E UTENSILI PER ESTERNI COMBI TOOLHOLDER FOR BORING BAR AND EXTERNAL TOOLS

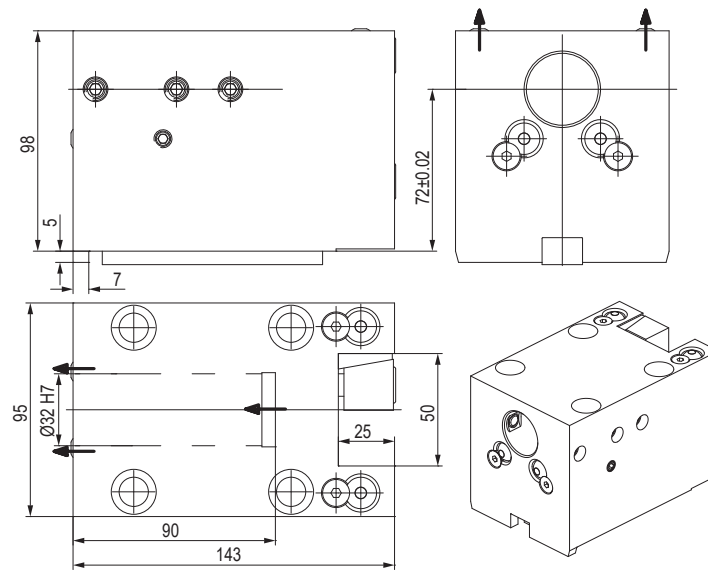

CODE N.	CLAMPING PLATE	CLAMPING SCREW COMP_2021-01	KEY COMP_2021-03	SCREW FOR KEY COMP_2021-04	COOLANT BALL COMP_2021-05	SCREW FOR BALL COMP_2021-06
128-11821	832-007360	811-102039	814-203310	811-101027	833-001470	811-108018

PORTAUTENSILE CON USCITA POLIGONALE POLIGONAL TOOLHOLDERS

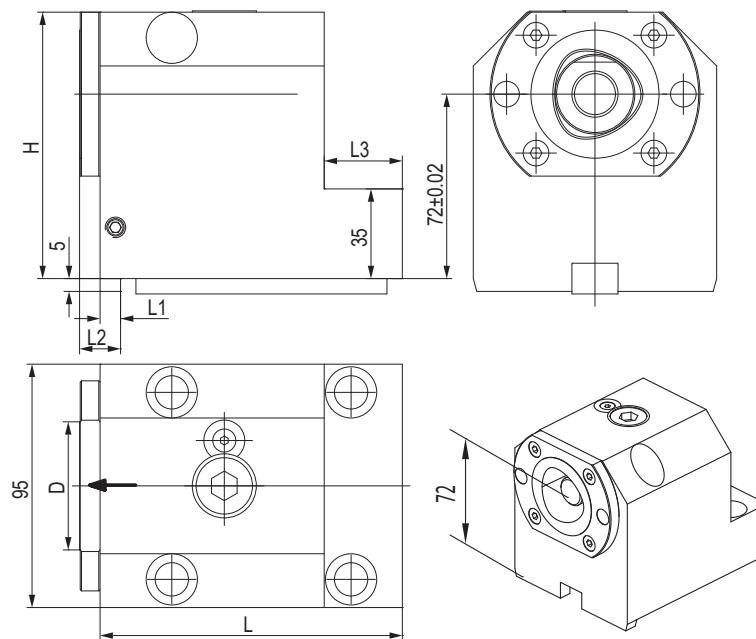

CODE N.	CAPTO	D	H	L	L1	L2	L3	CLAMPING UNIT	KEY	SCREW FOR KEY
128-11817	C40	40	96	116	6	12	38	CXC40-10	814-203310	811-101027
128-11805	C50	50	104	118	8	16	30,5	CXC50-10	814-203310	811-101027

PORTAUTENSILE CON USCITA POLIGONALE POLIGONAL TOOLHOLDERS

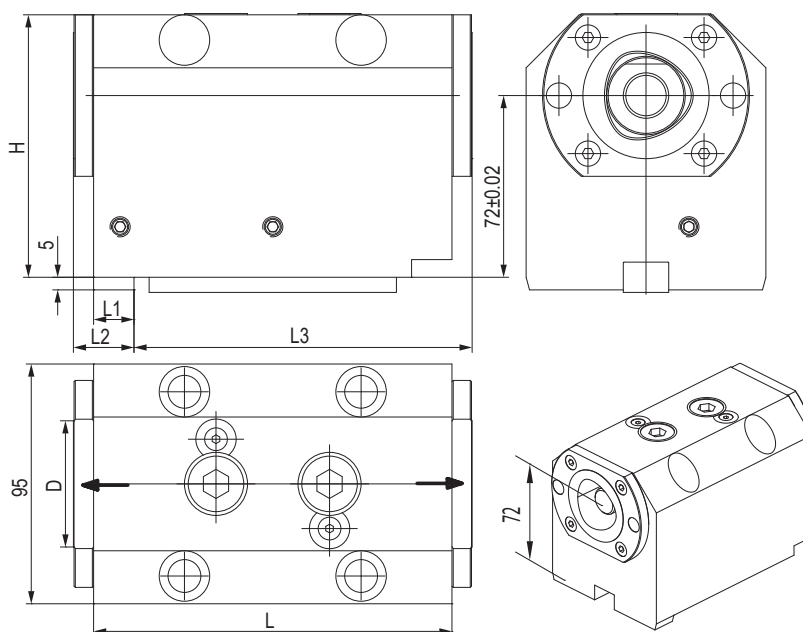

CODE N.	CAPTO	D	H	L	L1	L2	L3	CLAMPING UNIT	KEY	SCREW FOR KEY
128-11818	C40	40	96	123	13	19	116	CXC40-10	814-203310	811-101027
128-11807	C50	50	104	142	16	24	134	CXC50-10	814-203310	811-101027

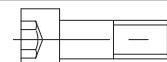

PORTAUTENSILE CON USCITA POLIGONALE POLIGONAL TOOLHOLDERS

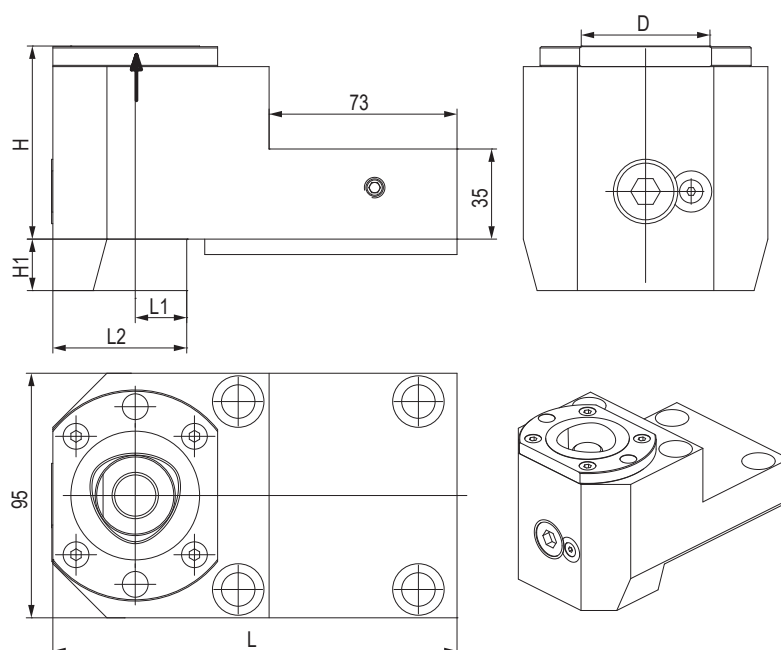

CODE N.	CAPTO	D	H	H1	L	L1	L2	CLAMPING UNIT	KEY	SCREW FOR KEY
128-11819	C40	40	70	13	141	12	36	CXC40-10	814-203310	811-101027
128-11809	C50	50	75	20	157	20	52	CXC50-10	814-203310	811-101027

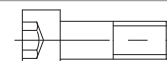

PORTAUTENSILE MOTORIZZATO ASSIALE STRAIGHT DRILLING AND MILLING HEAD

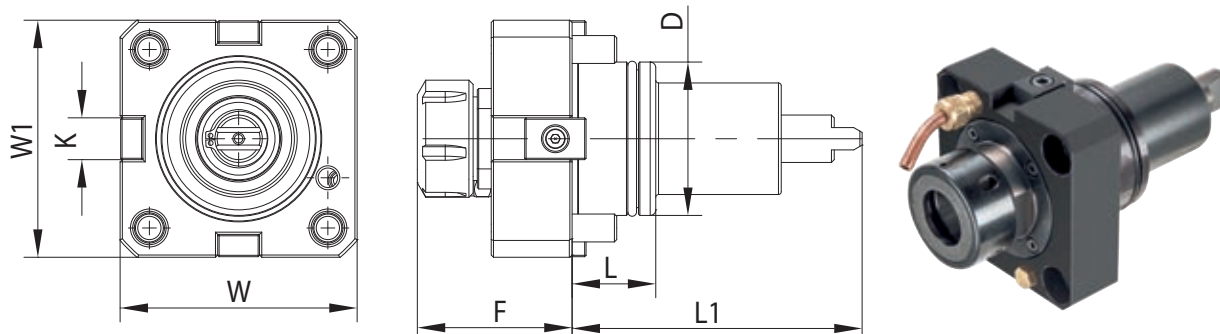

CODE N.	ER	D	F	K	L	L1	W	W1	MAX SPEED (Rpm)	I	MAX. TORQUE (Nm)	INTERNAL COOLING
124-06501	ER32	65	75	18	32	112	94	94	6000	1:1	70	no
124-06508	ER32	65	75	18	32	112	94	94	6000	1:1	70	yes

PORTAUTENSILE MOTORIZZATO RADIALE RADIAL DRILLING AND MILLING HEAD

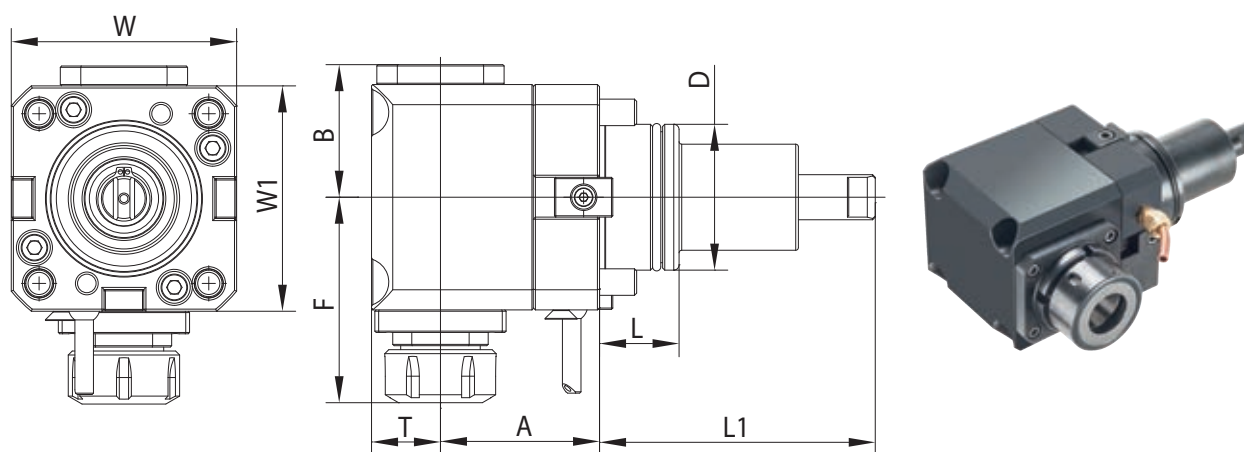

CODE N.	ER	D	A	B	F	L	L1	T	W	W1	MAX SPEED (Rpm)	I	MAX. TORQUE (Nm)	INTERNAL COOLING	P BAR
124-06502	ER32	65	72	59	110	32	112	36	94	94	6000	1:1	40	no	-
124-06512	ER32	65	72	59	110	32	110	38	94	94	6000	1:1	40	yes	20

BARRA DI CONTROLLO - CONTROL PIN

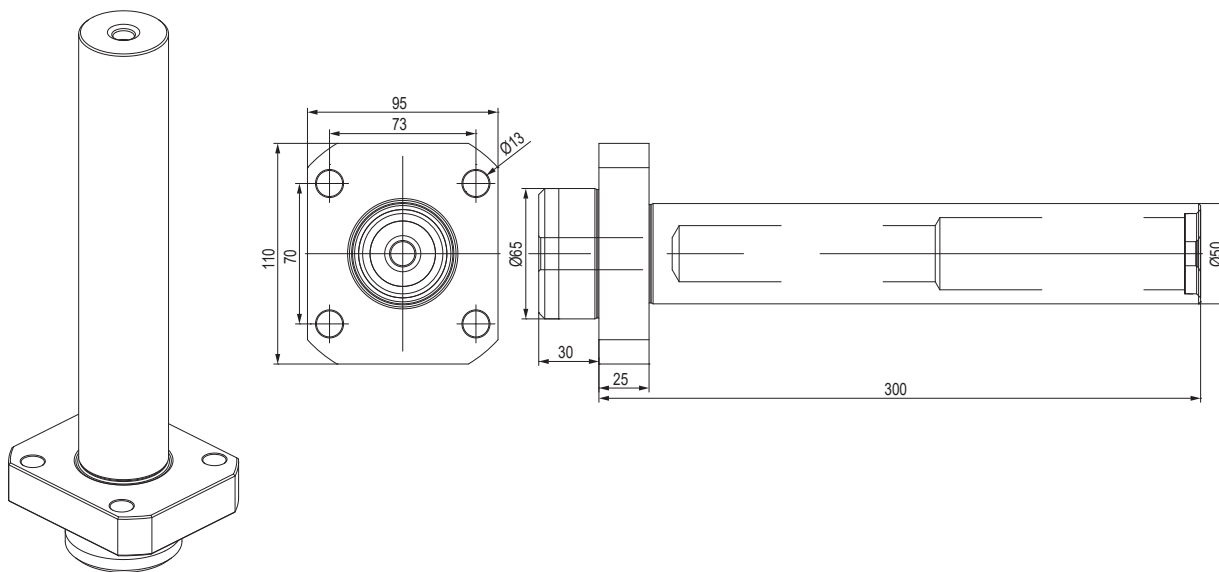

CODE N.

137-00199

TAPPO DI PROTEZIONE - PROTECTION COVER

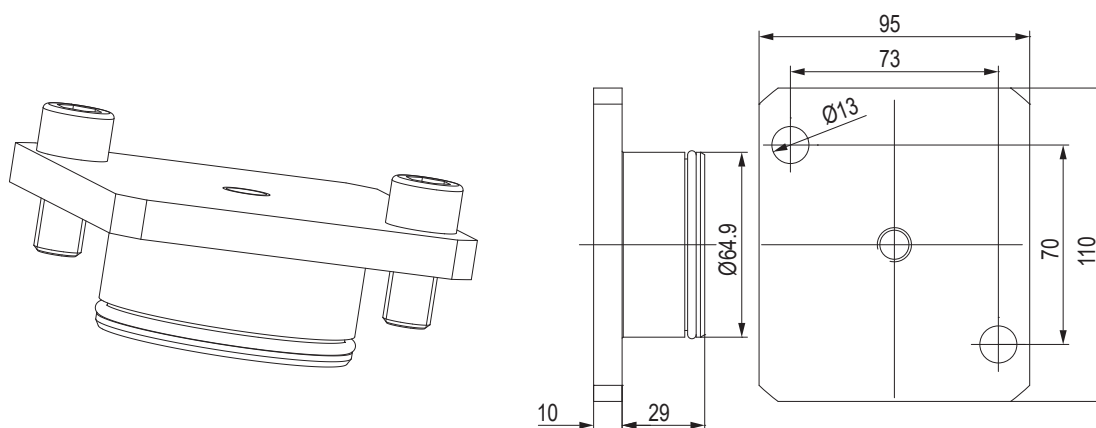

CODE N.

O RING



137-00254

823-101084

BUSSOLA PER PORTABARENO DRILL SOCKET FOR TOOLHOLDER

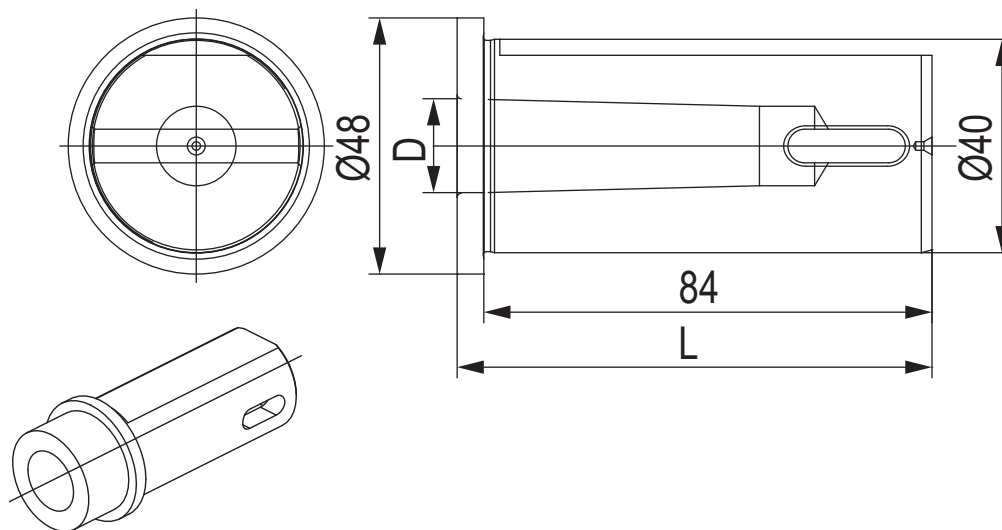

CODE N.	Ø	MORSE	D	L
114-34012	40	1	12,065	89
114-34013	40	2	17,780	89
114-34014	40	3	23,825	110

BUSSOLA PER PORTABARENO DRILL SOCKET FOR TOOLHOLDER

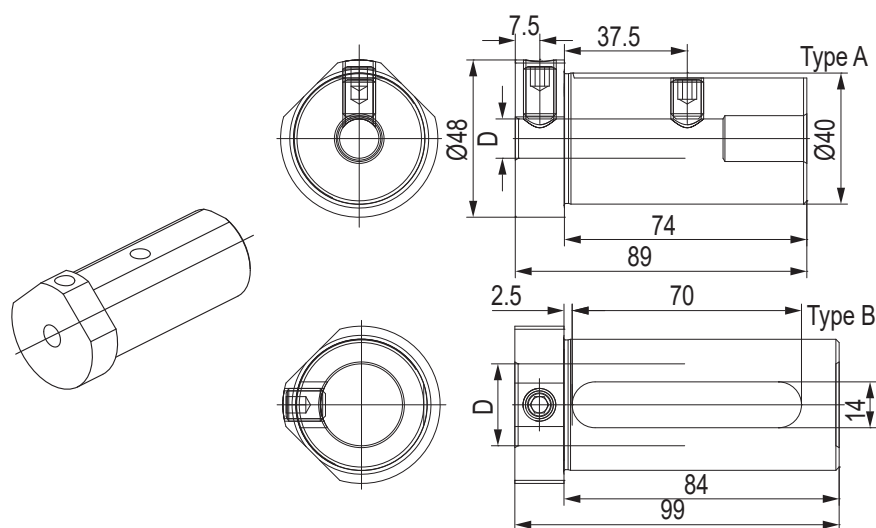

CODE N.	Ø	D	TYPE	SCREW1	SCREW2
165-64089	40	10	A	811-102037	811-102036
165-64090	40	12	A	811-102037	811-102036
165-64091	40	16	A	811-102037	811-102035
165-64092	40	20	B	811-102036	-
165-64093	40	25	B	811-102036	-
165-64094	40	32	B	811-102035	-



BUSSOLA PER PORTABARENO DRILL SOCKET FOR TOOLHOLDER

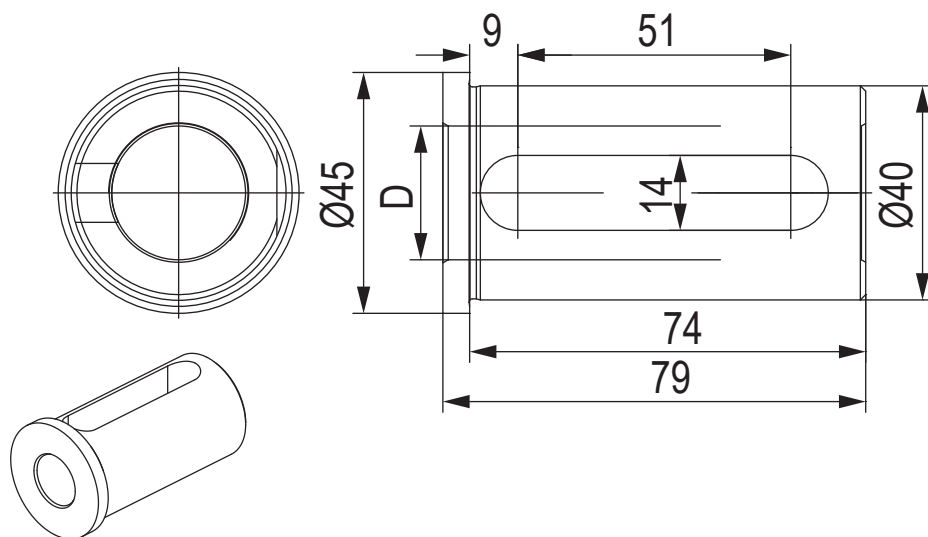

CODE N.	Ø	D
165-64095	40	20
165-64096	40	25
165-64097	40	32

BUSSOLA PER PORTABARENO BORING BAR SLEEVE FOR TOOLHOLDER

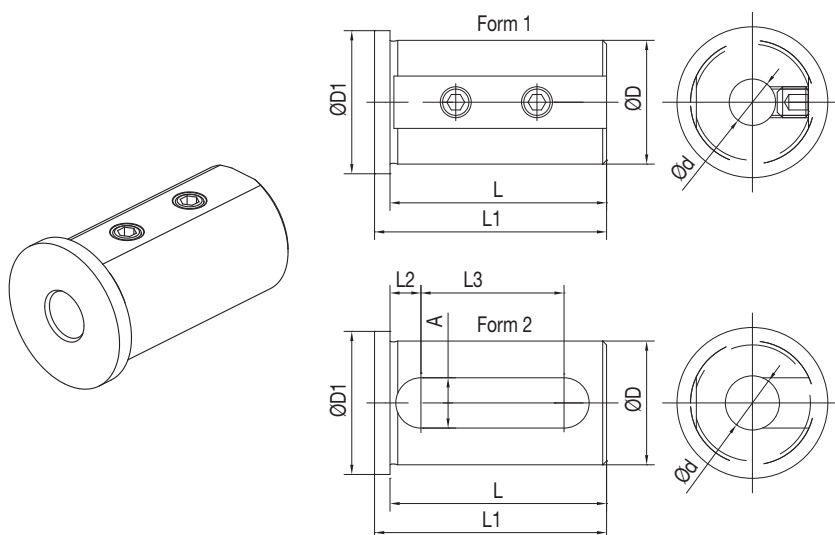

CODE N.	D	D	FORM	L	L1	L2	L3	A	D1
165-64247	40	8	1	71	75	-	-	-	45
165-64248	40	10	1	71	75	-	-	-	45
165-64249	40	12	1	71	75	-	-	-	45
165-64251	40	16	2	71	75	8	52	13	45
165-64253	40	20	2	71	75	8	52	13	45
165-64254	40	25	2	71	75	8	52	13	45
165-64255	40	32	2	71	75	8	52	13	45

BUSSOLA PER PORTABARENI BORING BAR SLEEVE FOR TOOLHOLDER

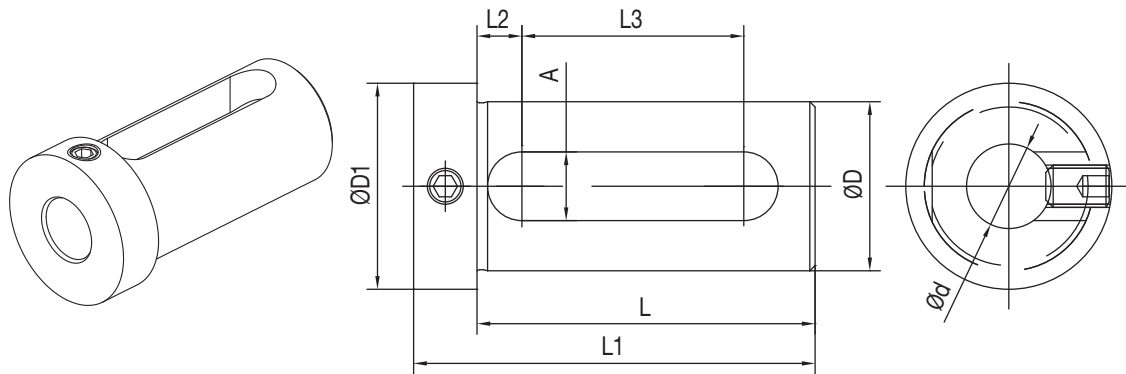

CODE N.	D	D	L	L1	L2	L3	A	D1
165-64241	40	16	74	88	9	51	14	48
165-64243	40	20	74	88	9	51	14	48
165-64244	40	25	74	88	9	51	14	48
165-64245	40	32	74	88	9	51	14	48
165-65017	50	25	84	98	9	61	14	59
165-65018	50	32	84	98	9	61	14	59
165-65019	50	40	84	98	9	61	14	59



DOOSAN PUMA
(BMT75)

400/480 (M,LM,XLM)
500 (M)
V550(M)
VT750 (TM, 2SP)

SAMSUNG
HYUNDAI WIA
HWACHEON

PL 45LM
LV800RM /SKT-V80R
RM / SKT400M / MA / MC / LMC
HI-TECH 550 / 700 / 7026
VT-550

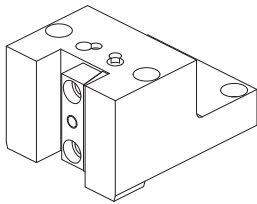

128-42508 25x25 mm
128-42516 32x32 mm

Face and O.D. cutting holder

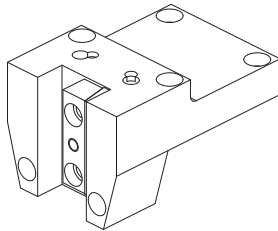

128-42509 25x25 mm
128-42510 32x32 mm

Face and O.D. cutting holder

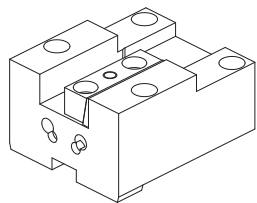

128-32506 25x25 mm

Face and O.D. cutting holder

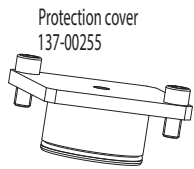

Protection cover
137-00255

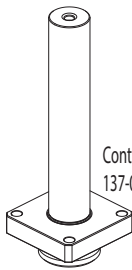

Control pin
137-00200

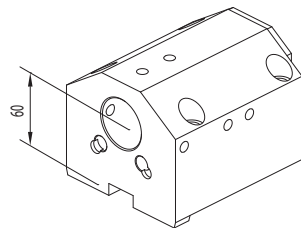

Combi tool holder
for boring bar
and insertdrill

128-22522 Ø40 mm
128-22523 Ø50 mm
128-22539 Ø60 mm

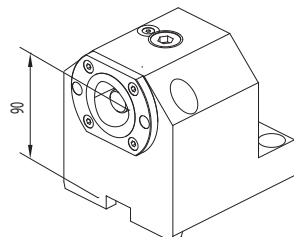

Boring bar holder
Poligonal

128-12515 (C50)
128-12528 (C63)

NEWS

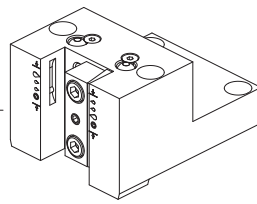

128-42508-IC 25x25 mm I.Coolant

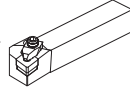

Qualified tool

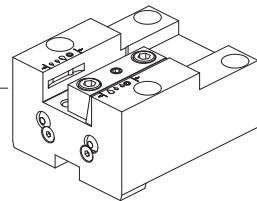

128-32506-IC 25x25 mm I.Coolant

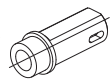

Drill socket D40
114-34012 <MT1>
114-34013 <MT2>
114-34014 <MT3>

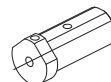

Boring bar sleeve D40
165-64089 (Ø10)
165-64090 (Ø12)
165-64091 (Ø16)

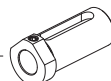

Boring bar sleeve D40
165-64092 (Ø20)
165-64093 (Ø25)
165-64094 (Ø32)

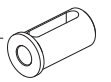

Throw-away drill socket D40
165-64095 (Ø20)
165-64096 (Ø25)
165-64097 (Ø32)

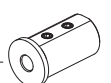

Boring bar sleeve D40
165-64247 (Ø8)
165-64248 (Ø10)
165-64249 (Ø12)

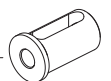

Boring bar sleeve D40
165-64251 (Ø16)
165-64253 (Ø20)
165-64254 (Ø25)
165-64255 (Ø32)

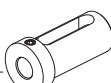

Boring bar sleeve D40
165-64241 (Ø16)
165-64243 (Ø20)
165-64244 (Ø25)
165-64245 (Ø32)

Boring bar sleeve D50
165-65017 (Ø25)
165-65018 (Ø32)
165-65019 (Ø40)
Boring bar sleeve D60
165-66056 (Ø25)
165-66057 (Ø32)
165-66058 (Ø40)
165-66059 (Ø50)

CONNECTION

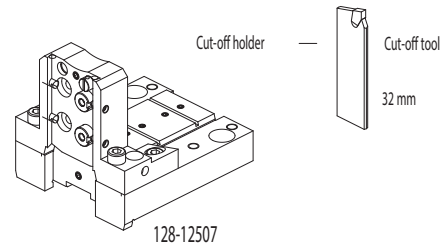
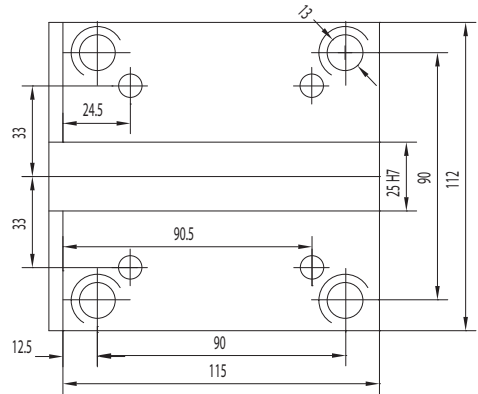

Cut-off holder

Cut-off tool

32 mm

128-12507

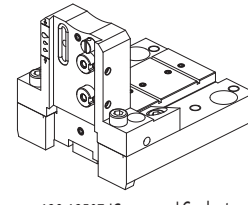

128-12507-IC I.Coolant

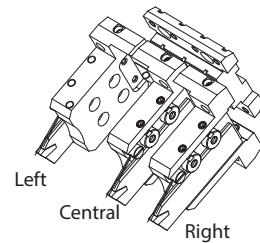

Left

Central

Right

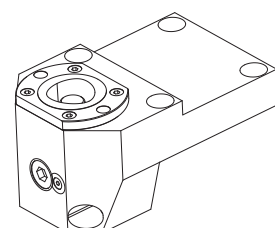

Face and O.D. cutting holder
Poligonal

128-12517 (C50)
128-12529 (C63)

NEWS

CONNECTION

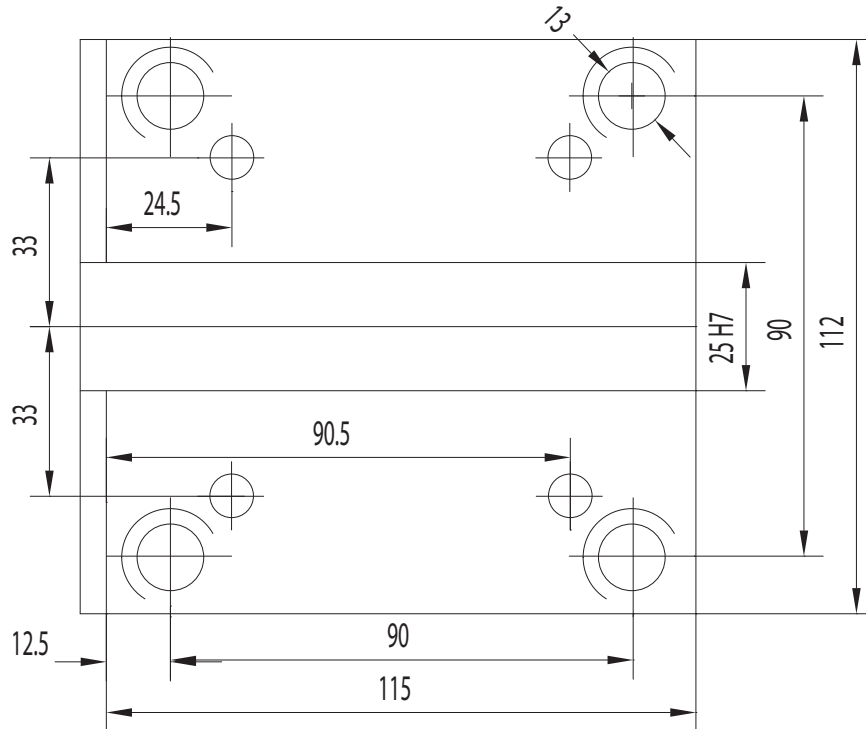

PORTAUTENSILE RADIALE - RADIAL TOOLHOLDERS

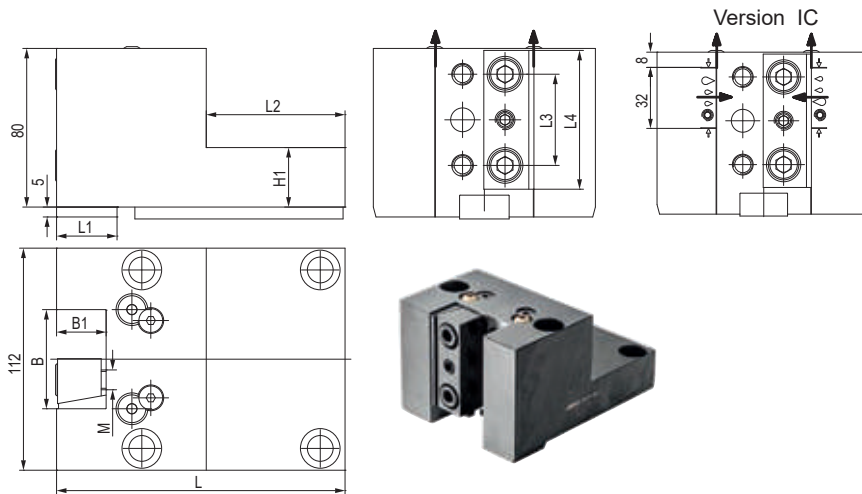

CODE N.	INTERNAL COOLANT	B	B1	H1	L	L1	L2	L3	L4	M
128-42508	NO	50	25	30	145.5	30.5	70	46	70	M10
128-42508-IC	YES	50	25	30	145.5	30.5	70	46	70	M10
128-42516	NO	64	32	45	152.5	35	80	52	76	M12

CODE N.	CLAMPING PLATE	KEY	SCREW FOR KEY	COOLANT BALL	SCREW FOR BALL
128-42508	832-007010	814-203480	811-101027	833-001470	811-108018
128-42508-IC	832-007010	814-203480	811-101027	833-001470	811-108018
128-42516	832-007970	814-203480	811-101027	833-001470	811-108018

PORTAUTENSILE RADIALE - RADIAL TOOLHOLDERS

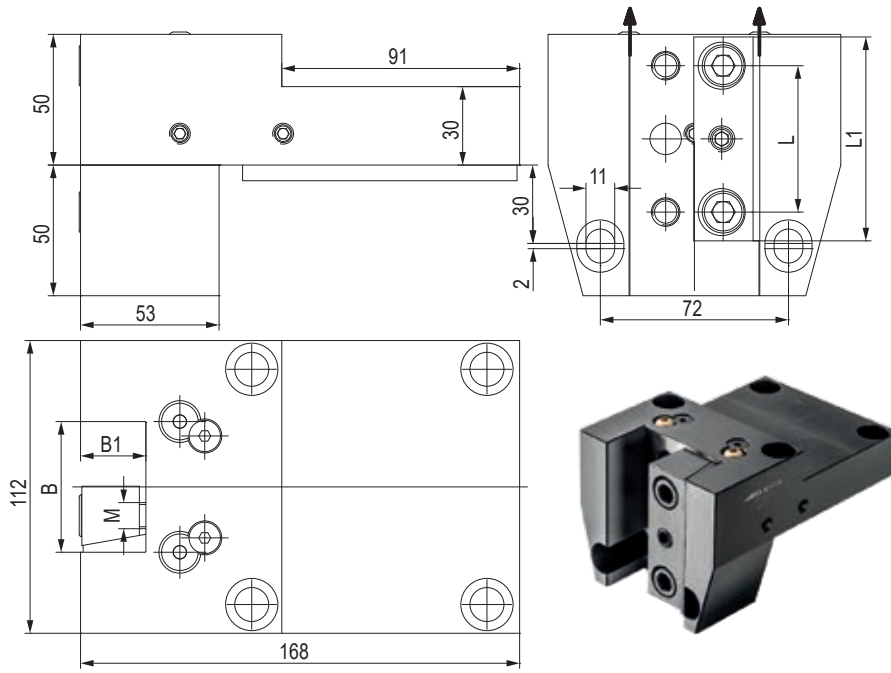

CODE N.	B	B1	L	L1	M	CLAMPING PLATE	KEY	SCREW FOR KEY	COOLANT BALL	SCREW FOR BALL
128-42509	50	25	56	78	M10					
128-42510	64	32	60	88	M12	832-007340	814-203480	811-101027	833-001470	811-108018

PORTAUTENSILE ASSIALE - AXIAL TOOLHOLDERS

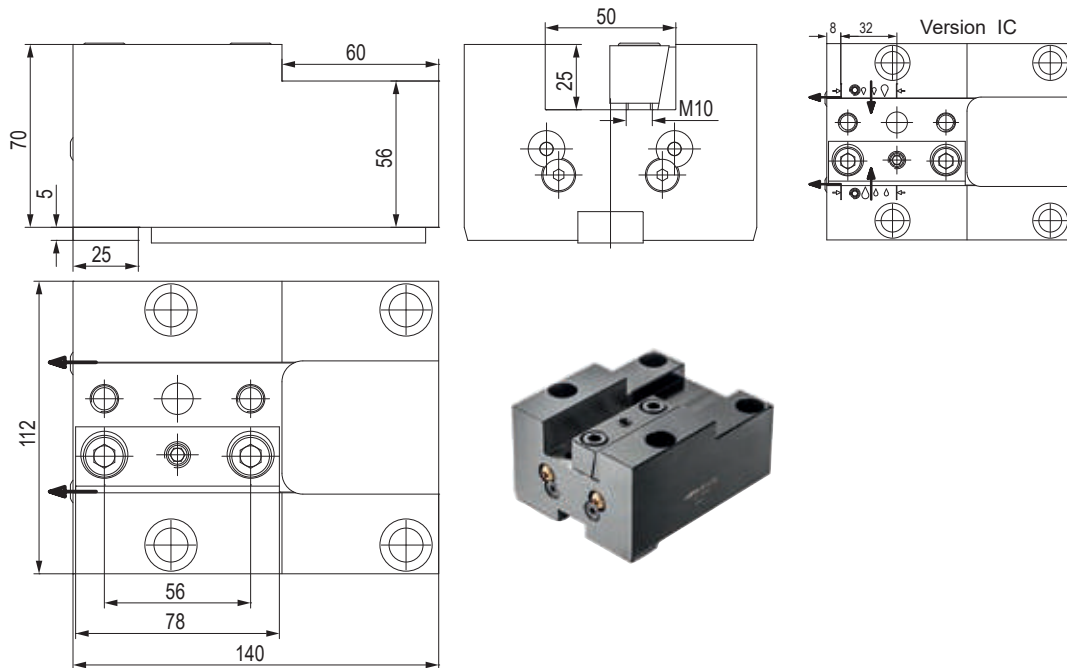

CODE N.	INTERNAL COOLANT	CLAMPING PLATE	KEY	SCREW FOR KEY	COOLANT BALL	SCREW FOR BALL
128-32506	NO					
128-32506-IC	YES	832-007340	814-203480	811-101027	833-001470	811-108018

PORTALAMA - CUT-OFF TOOLHOLDERS

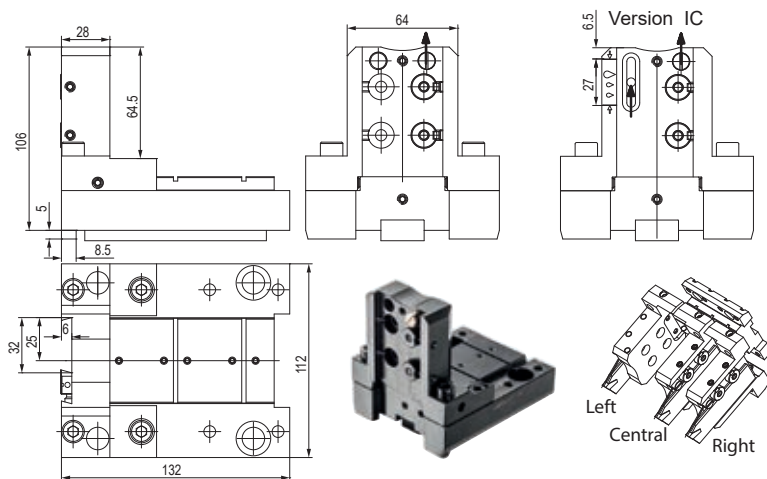

CODE N.	INTERNAL COOLANT	KEY	SCREW FOR KEY	COOLANT NOZZLE	O RING FOR COOLANT NOZZLE	O RING FOR INT. COOLANT	O RING FOR BODY
128-12507	NO	814-203480	811-101026	833-001490	823-101058	-	823-101061
128-12507-IC	YES	814-203480	811-101026	833-001490	823-101058	823-201140	823-101061

CODE N.	SHIM PLATE	SCREW FOR PLATE	CLAMPING PIN	SPRING	CLAMPING SCREW	SCREW
128-12507	832-014449	811-108037	832-014450	824-300012	811-101029	811-104013
128-12507-IC	832-014449	811-108037	832-014450	824-300012	811-101029	811-104013

PORTAUTENSILE COMBINATO PER BARENI E PUNTE A INSERTI COMBI TOOLHOLDER FOR BORING BAR AND INSERT DRILL

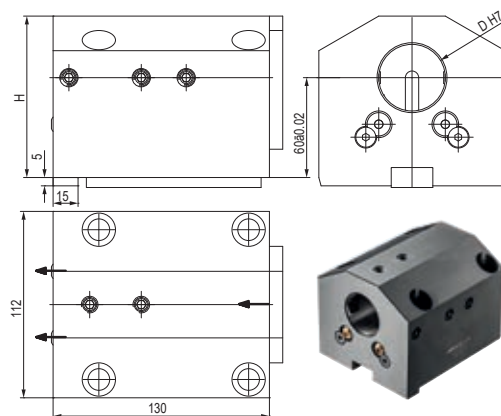

CODE N.	D	H	CLAMPING SCREW1 (D40-M10X30) (D50-M12X30) (D60-M12X25)	CLAMPING SCREW2 (D40-M10X16) - (D50-M12X12)	KEY	SCREW FOR KEY
128-22522	40	97	811-102040	811-102037	814-203480	811-101027
128-22523	50	97	811-102046	811-102064	814-203480	811-101027
128-22539	60	102	811-102045	811-102064	814-203480	811-101027

CODE N.	COOLANT BALL	SCREW FOR BALL	COVER	SCREW FOR COVER
128-22522	833-001470	811-108018	832-003369	811-101016
128-22523	833-001470	811-108018	832-003369	811-101016
128-22539	833-001470	811-108018	832-003385	811-101016

PORTAUTENSILE CON USCITA POLIGONALE POLIGONAL TOOLHOLDERS

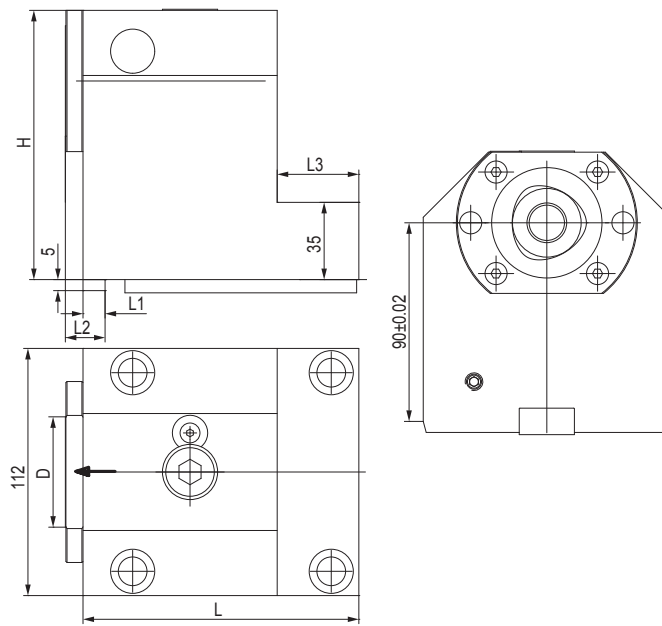

CODE N.	CAPTO	D	H	L	L1	L2	L3	CLAMPING UNIT	KEY	SCREW FOR KEY
128-12515	C50	50	92	125	10	18	37	CXC50-10	814-203480	811-101027
128-12528	C63	63	102	127	12	21	-	CXC63-10	814-203480	811-101027

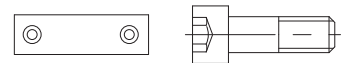

PORTAUTENSILE CON USCITA POLIGONALE POLIGONAL TOOLHOLDERS

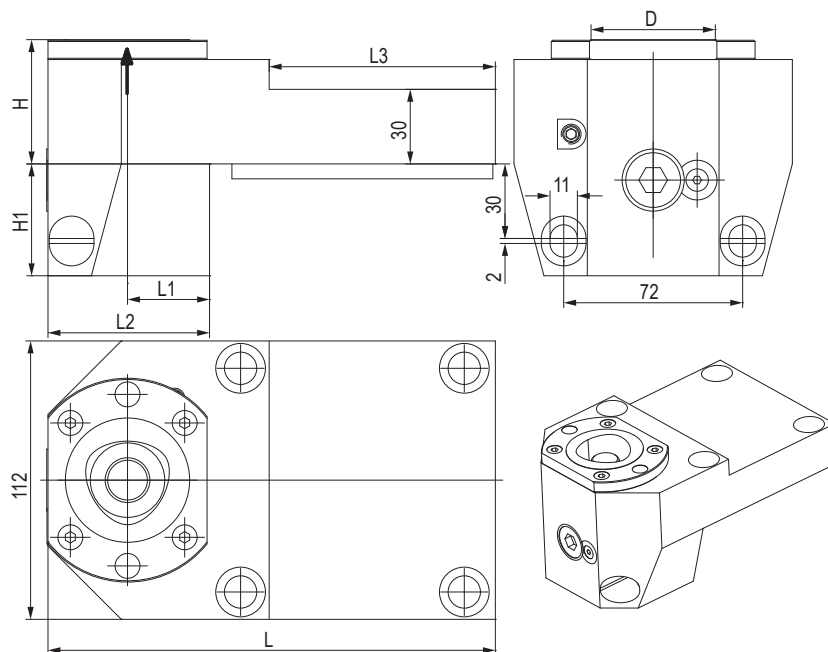

CODE N.	CAPTO	D	H	H1	L	L1	L2	L3	CLAMPING UNIT	KEY	SCREW FOR KEY
128-12517	C50	50	50	45	180	33	65	91	CXC50-10	814-203480	811-101027
128-12529	C63	63	45	57	204	47	89	120	CXC63-10	814-203480	811-101027

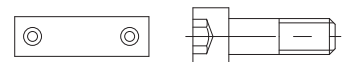

BARRA DI CONTROLLO - CONTROL PIN

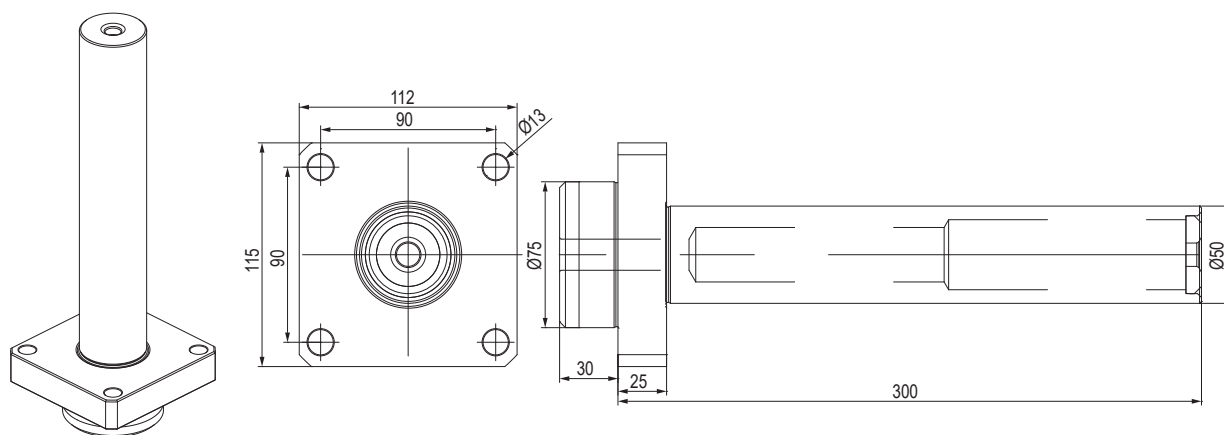

CODE N.

137-00200

TAPPO DI PROTEZIONE - PROTECTION COVER

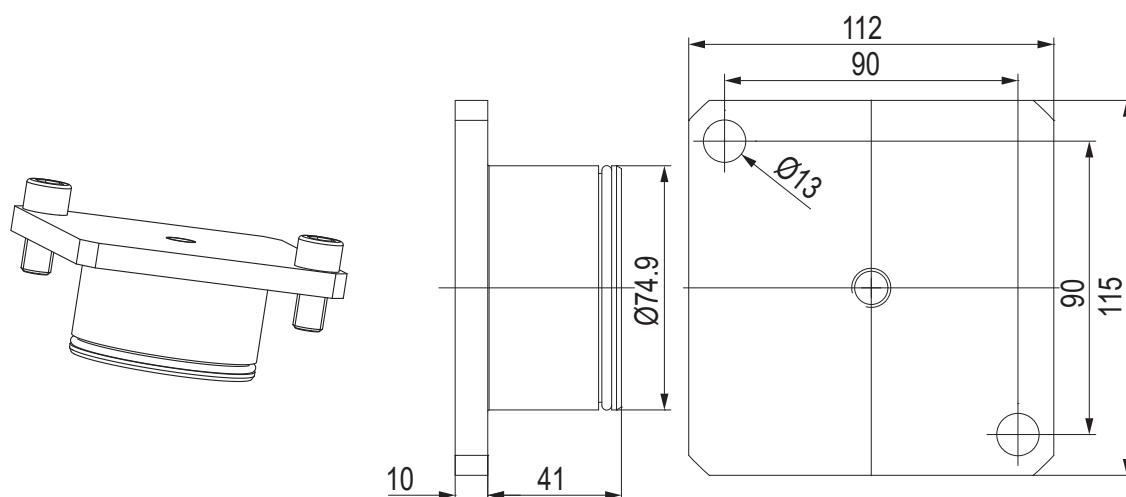

CODE N.

O RING



137-00255

823-101115

BUSSOLA PER PORTABARENI DRILL SOCKET FOR TOOLHOLDER

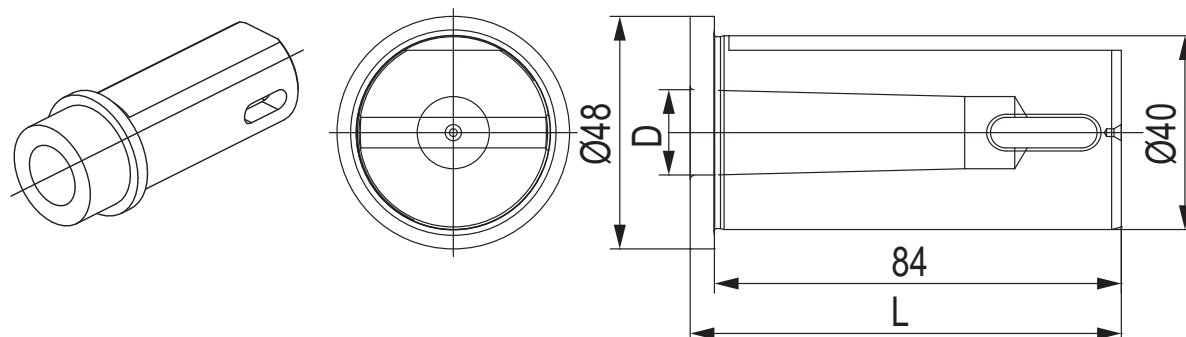

CODE N.	Ø	MORSE	D	L
114-34012	40	1	12,065	89
114-34013	40	2	17,780	89
114-34014	40	3	23,825	110

BUSSOLA PER PORTABARENI BORING BAR SLEEVE FOR TOOLHOLDER

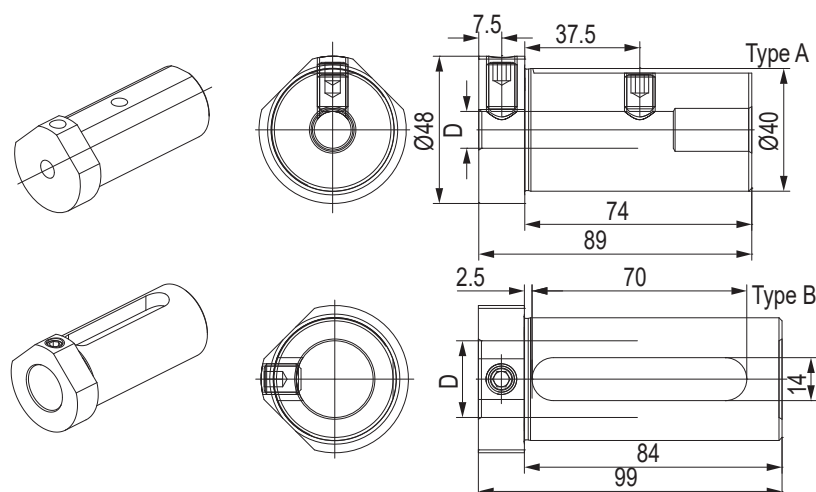

CODE N.	Ø	D	TYPE	SCREW1	SCREW2
165-64089	40	10	A	811-102037	811-102036
165-64090	40	12	A	811-102037	811-102036
165-64091	40	16	A	811-102037	811-102035
165-64092	40	20	B	811-102036	-
165-64093	40	25	B	811-102036	-
165-64094	40	32	B	811-102035	-

BUSSOLA PER PORTABARENI BORING BAR SLEEVE FOR TOOLHOLDER

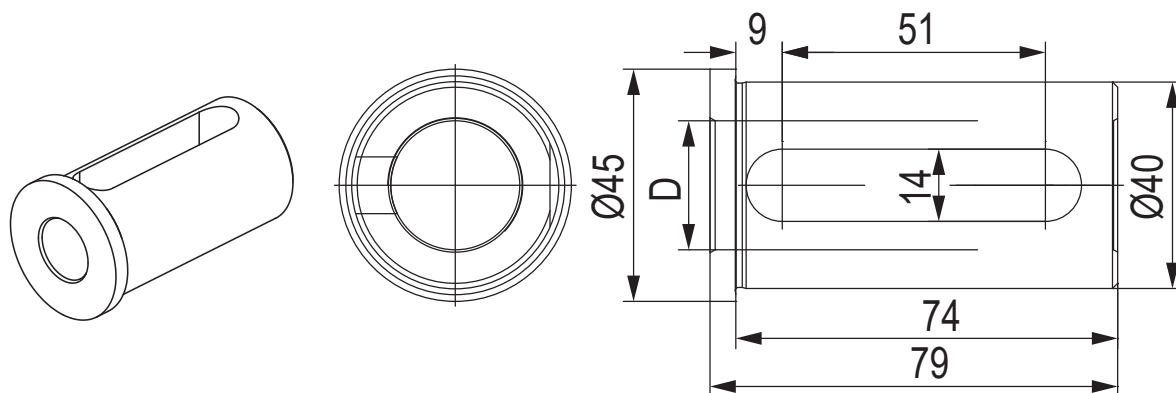

CODE N.	Ø	D
165-64095	40	20
165-64096	40	25
165-64097	40	32

BUSSOLA PER PORTABARENI BORING BAR SLEEVE FOR TOOLHOLDER

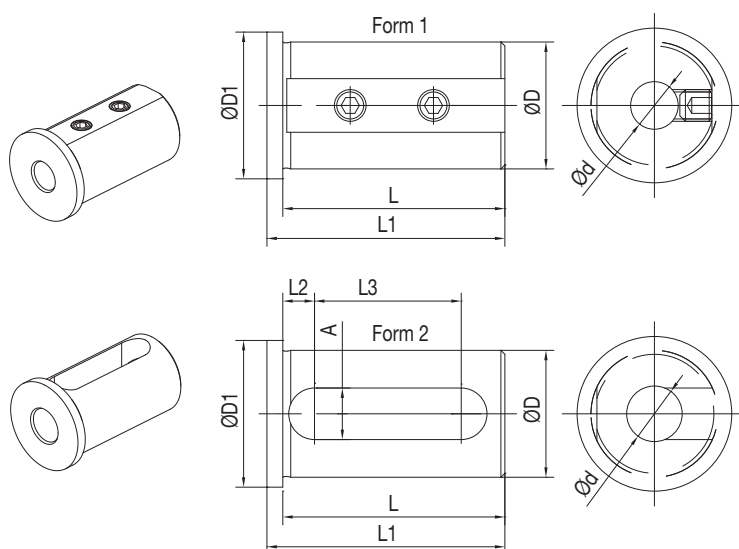

CODE N.	D	d	FORM	L	L1	L2	L3	A	D1
165-64247	40	8	1	71	75	-	-	-	45
165-64248	40	10	1	71	75	-	-	-	45
165-64249	40	12	1	71	75	-	-	-	45
165-64251	40	16	2	71	75	8	52	13	45
165-64253	40	20	2	71	75	8	52	13	45
165-64254	40	25	2	71	75	8	52	13	45
165-64255	40	32	2	71	75	8	52	13	45

BUSSOLA PER PORTABARENI BORING BAR SLEEVE FOR TOOLHOLDER

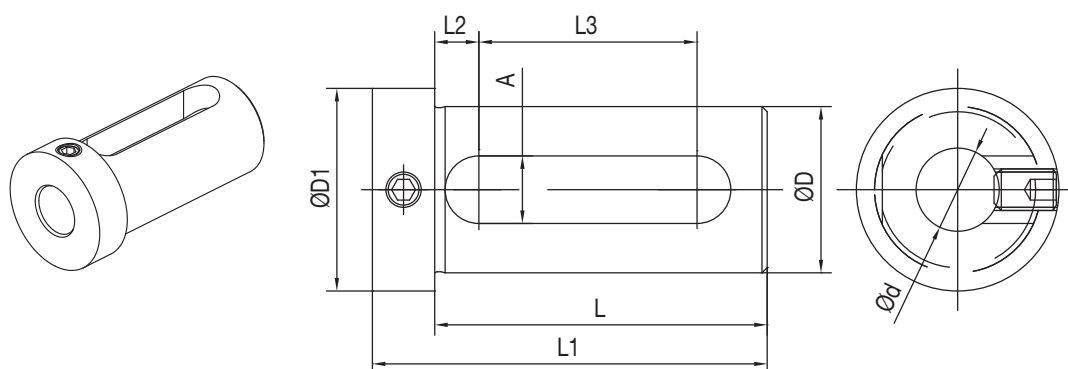

CODE N.	D	d	L	L1	L2	L3	A	D1
165-64241	40	16	74	88	9	51	14	48
165-64243	40	20	74	88	9	51	14	48
165-64244	40	25	74	88	9	51	14	48
165-64245	40	32	74	88	9	51	14	48
165-65017	50	25	84	98	9	61	14	59
165-65018	50	32	84	98	9	61	14	59
165-65019	50	40	84	98	9	61	14	59
165-66056	60	25	94	108	9	71	14	69
165-66057	60	32	94	108	9	71	14	69
165-66058	60	40	94	108	9	71	14	69
165-66059	60	50	94	108	9	71	14	69



DOOSAN PUMA (BMT85)

600M/LM
700M/LM
800M/LM
VT900M/TM
VT1100M

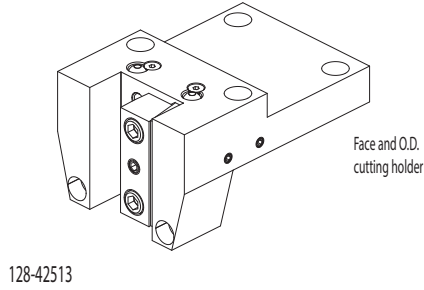

Face and O.D. cutting holder

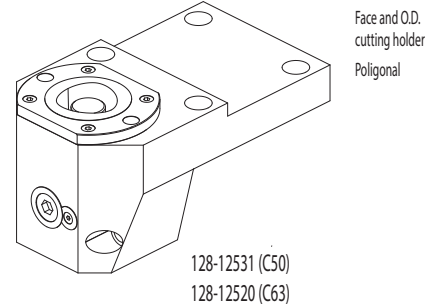

Face and O.D. cutting holder
Poligonal

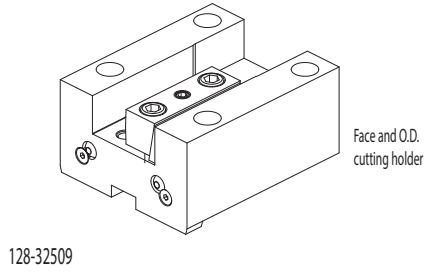

Face and O.D. cutting holder

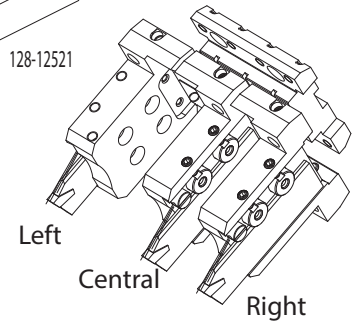
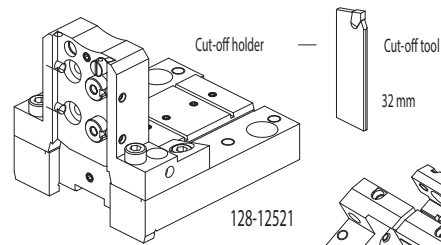
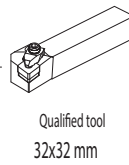

ACCESSORIES

Boring bar sleeve D50

- 115-65053 (Ø12)
- 115-65013 (Ø16)
- 115-65014 (Ø20)
- 115-65015 (Ø25)
- 115-65016 (Ø32)

Boring bar sleeve D60

- 115-66017 (Ø20)
- 115-66018 (Ø25)
- 115-66019 (Ø32)
- 115-66020 (Ø40)

Boring bar sleeve D50

- 115-65017 (Ø40)

Boring bar sleeve D60

- 115-66021 (Ø50)

Boring bar sleeve D50

- 165-65017 (Ø25)
- 165-65018 (Ø32)
- 165-65019 (Ø40)

Boring bar sleeve D60

- 165-66056 (Ø25)
- 165-66057 (Ø32)
- 165-66058 (Ø40)
- 165-66059 (Ø50)

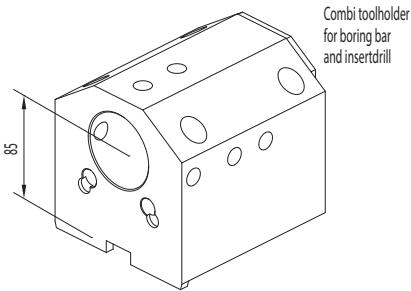

128-22528 Ø50 mm
128-22529 Ø60 mm

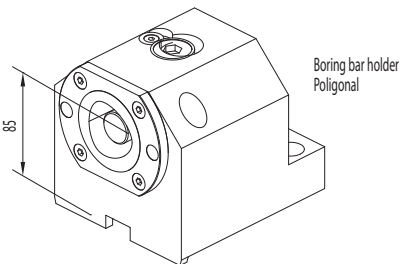

128-12530 (C50)
128-12519 (C63)

CONNECTION

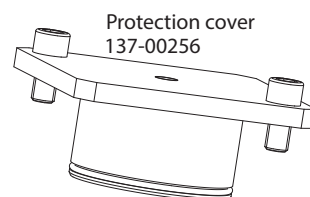
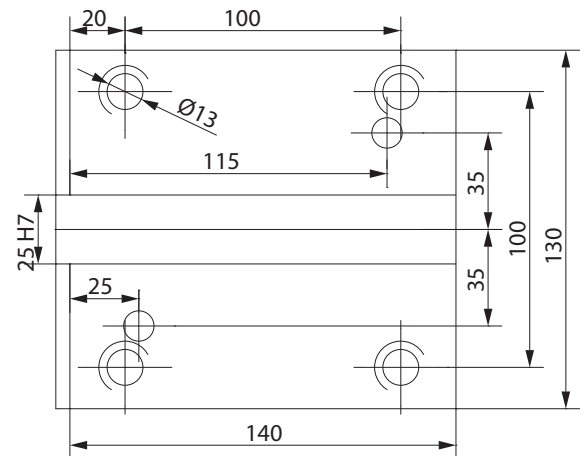



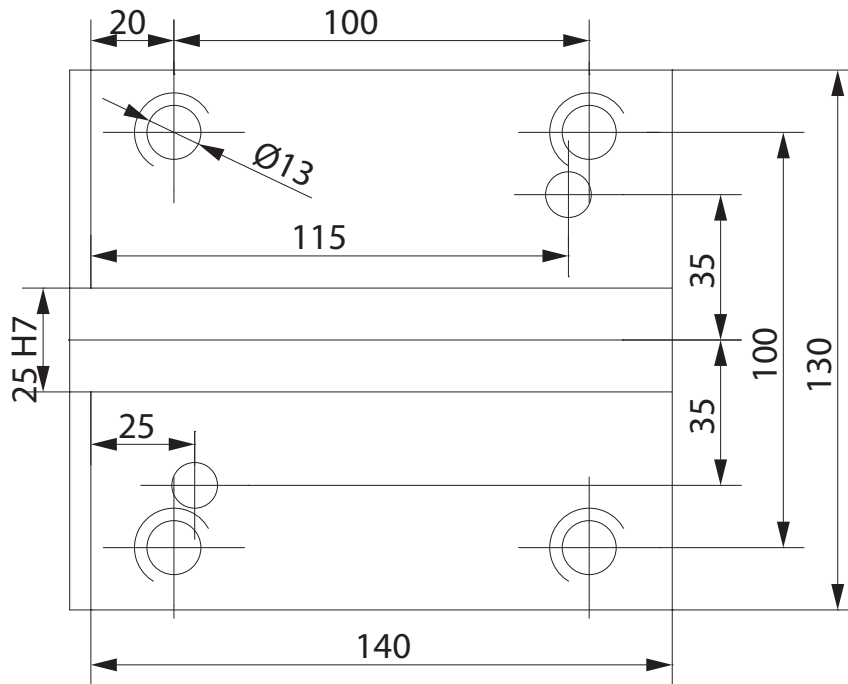

CONNECTION

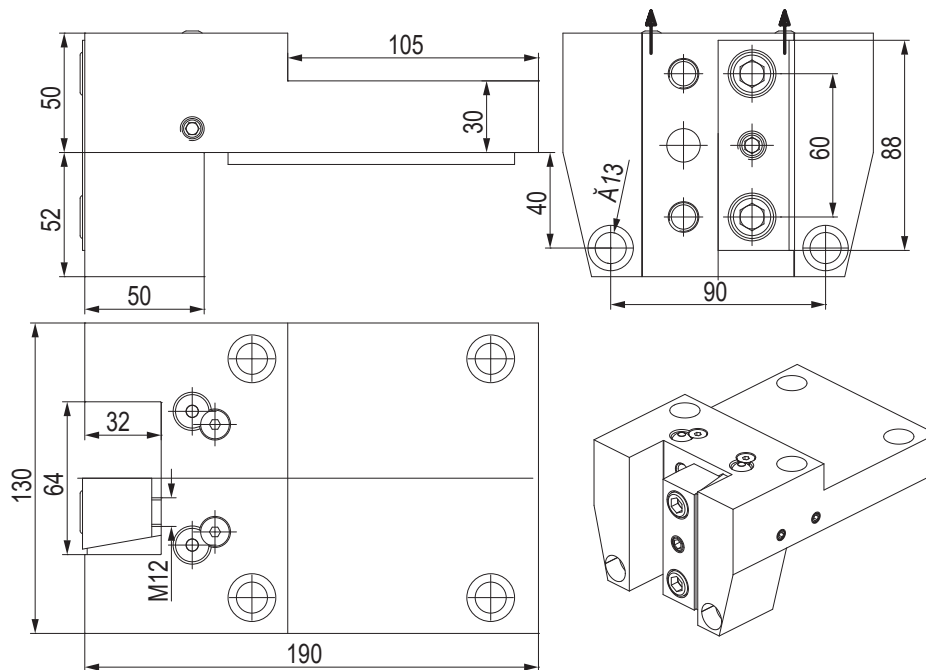

PORTAUTENSILE RADIALE - RADIAL TOOLHOLDERS

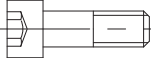

CODE N.	CLAMPING PLATE	KEY	SCREW FOR KEY	COOLANT BALL	SCREW FOR BALL
128-42513					
128-42513	832-007170	814-203350	811-101027	833-001470	811-108018

PORTAUTENSILE ASSIALE - AXIAL TOOLHOLDERS

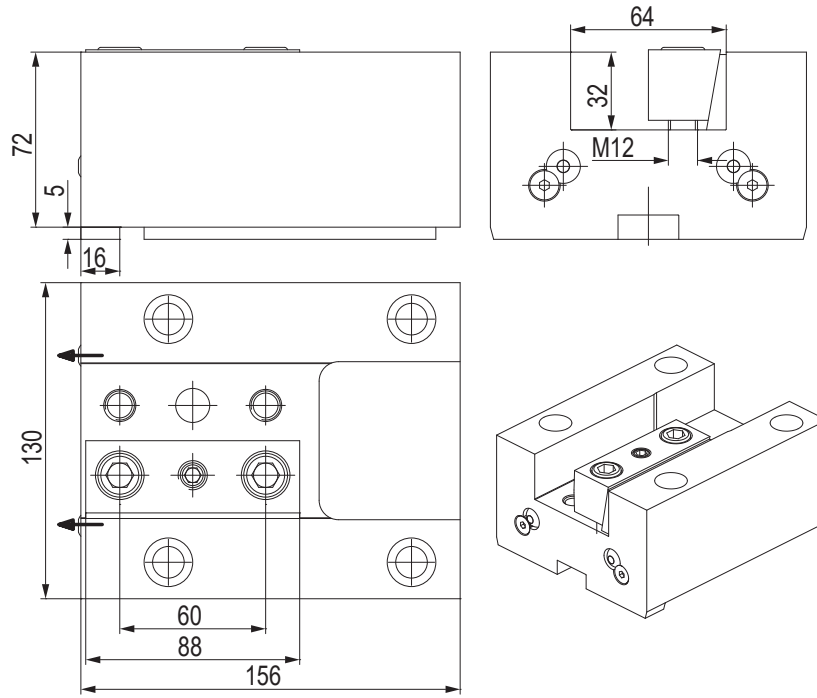

CODE N.	CLAMPING PLATE	KEY	SCREW FOR KEY	COOLANT BALL	SCREW FOR BALL
128-32509	832-007170	814-203350	811-101027	833-001470	811-108018

PORTALAMA - CUT-OFF HOLDERS

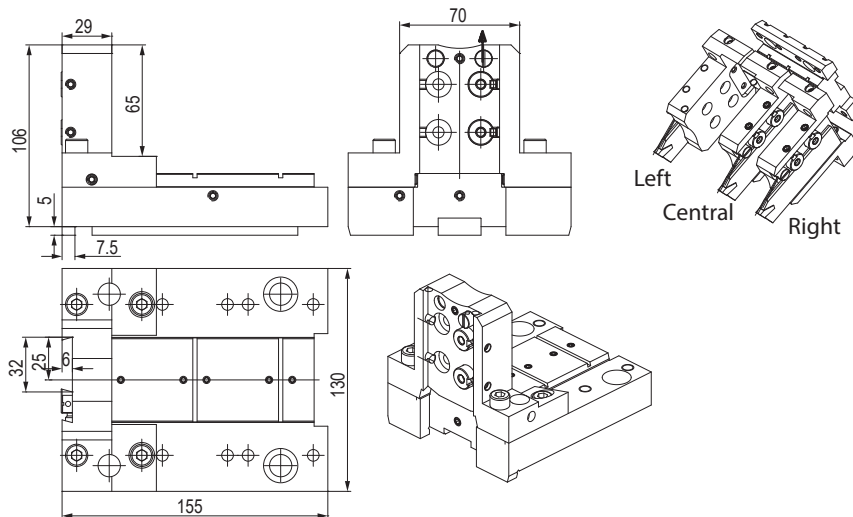

CODE N.	KEY	SCREW FOR KEY	COOLANT NOZZLE	O RING FOR COOLANT NOZZLE	O RING FOR BODY
128-12521	814-203350	811-101026	833-001490	823-101058	823-101061

CODE N.	SHIM PLATE	SCREW FOR PLATE	CLAMPING PIN	SPRING	CLAMPING SCREW	SCREW
128-12521	832-014449	811-108037	832-014450	824-300012	811-101029	811-104013

PORTAUTENSILE COMBINATO PER BARENI E PUNTE A INSERTI COMBI TOOLHOLDER FOR BORING BAR AND INSERTDRILL

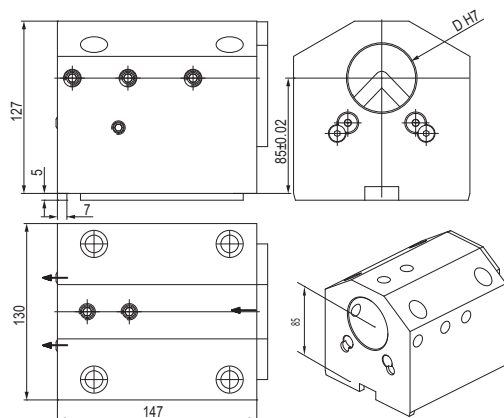

CODE N.	D	CLAMPING SCREW1 (M12X35)	CLAMPING SCREW2 (D50-M12X16) - (D60-M12X12)	KEY	SCREW FOR KEY
128-22528	50	811-102047	811-102043	814-203350	811-101027
128-22529	60	811-102047	811-102064	814-203350	811-101027

CODE N.	COOLANT BALL	SCREW FOR BALL	COVER	SCREW FOR COVER
128-22528	833-001470	811-108018	832-003389	811-101016
128-22529	833-001470	811-108018	832-003389	811-101016

PORTAUTENSILE CON USCITA POLIGONALE POLIGONAL TOOLHOLDERS

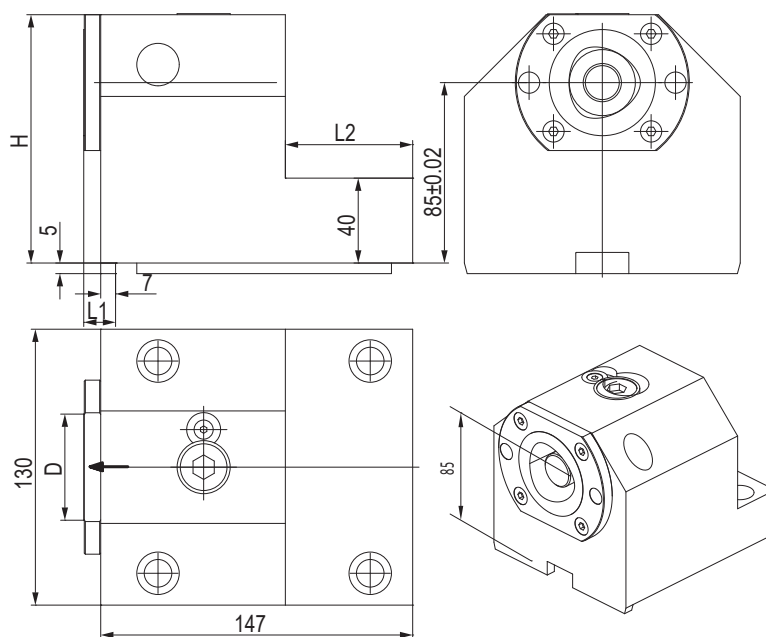

CODE N.	CAPTO	D	H	L1	L2	CLAMPING UNIT	KEY	SCREW FOR KEY
128-12530	C50	50	117	15	60	CXC50-10	814-203350	811-101027
128-12519	C63	63	127	16	39	CXC63-10	814-203350	811-101027

PORTAUTENSILE CON USCITA POLIGONALE POLIGONAL TOOLHOLDERS

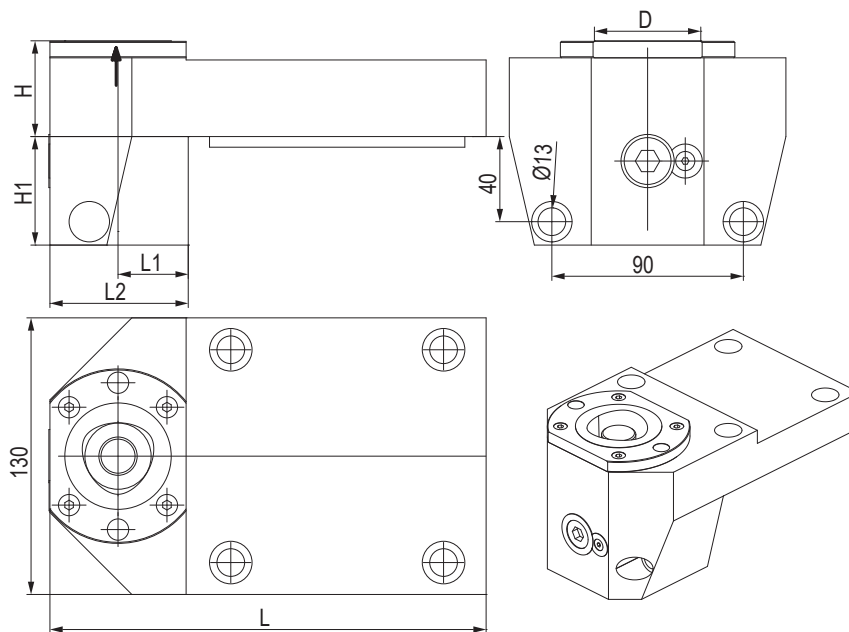

CODE N.	CAPTO	D	H	H1	L	L1	L2	CLAMPING UNIT	KEY	SCREW FOR KEY
128-12531	C50	50	45	51	205	33	65	CXC50-10	814-203350	811-101027
128-12520	C63	63	50	67	225	43	85	CXC63-10	814-203350	811-101027

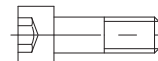

TAPPO DI PROTEZIONE - PROTECTION COVER

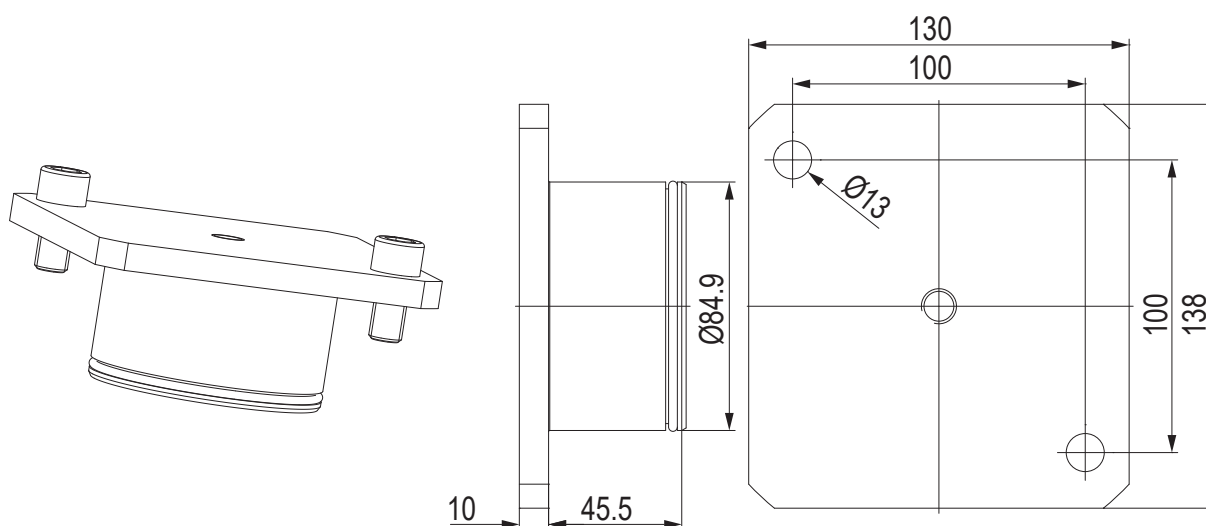

CODE N.	O RING
137-00256	823-101116



BUSSOLA PER PORTABARENI BORING BAR SLEEVE FOR TOOLHOLDER

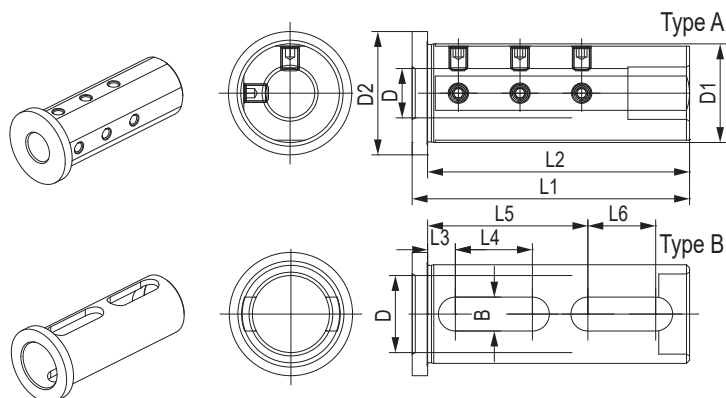

CODE N.	D1	D	D2	L1	L2	L3	L4	L5	L6	B	TYPE	SCREW
115-65053	50	12	60	130	125	-	-	-	-	-	A	811-102078
115-65013	50	16	60	130	125	-	-	-	-	-	A	811-102029
115-65014	50	20	60	130	125	-	-	-	-	-	A	811-102062
115-65015	50	25	60	130	125	-	-	-	-	-	A	811-102028
115-65016	50	32	60	130	125	-	-	-	-	-	A	811-102026
115-65017	50	40	60	130	125	10	45	75	37	13	B	-
115-66017	60	20	70	140	135	-	-	-	-	-	A	811-102038
115-66018	60	25	70	140	135	-	-	-	-	-	A	811-102037
115-66019	60	32	70	140	135	-	-	-	-	-	A	811-102036
115-66020	60	40	70	140	135	-	-	-	-	-	A	811-102035
115-66021	60	50	70	140	135	15	40	83	28	13	B	-



BUSSOLA PER PORTABARENI BORING BAR SLEEVE FOR TOOLHOLDER

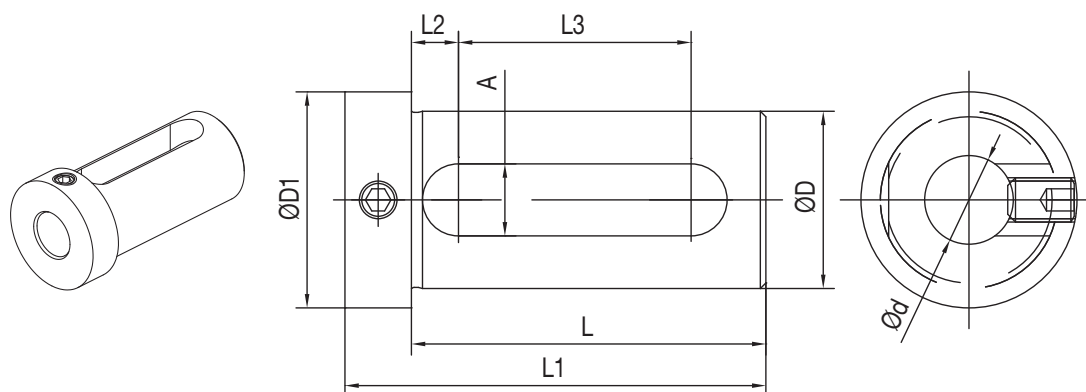

CODE N.	D	d	L	L1	L2	L3	A	D1
165-65017	50	25	84	98	9	61	14	59
165-65018	50	32	84	98	9	61	14	59
165-65019	50	40	84	98	9	61	14	59
165-66056	60	25	94	108	9	71	14	69
165-66057	60	32	94	108	9	71	14	69
165-66058	60	40	94	108	9	71	14	69
165-66059	60	50	94	108	9	71	14	69

MAZAK NEXUS SQT100/150

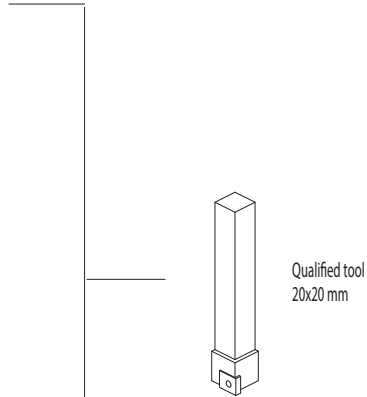
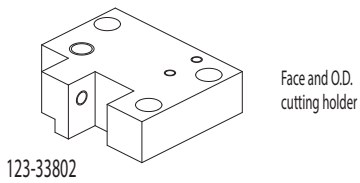
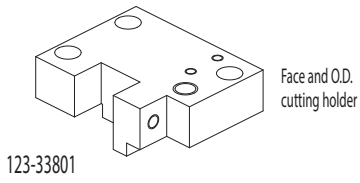

CONNECTION

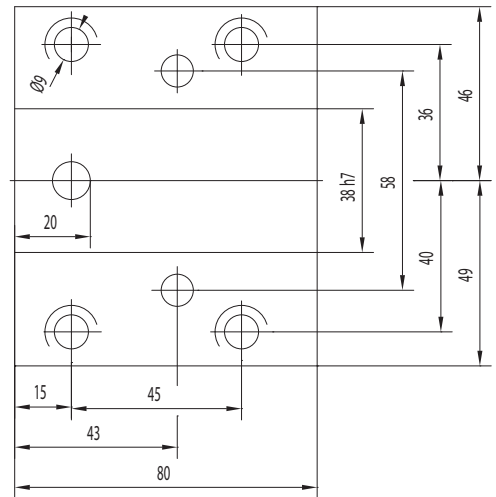

ACCESSORIES

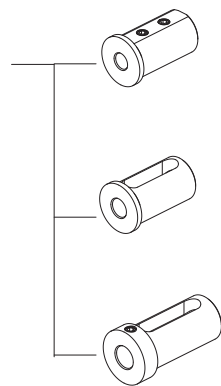
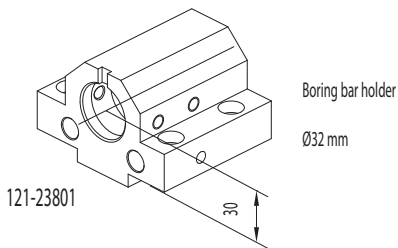

- Boring bar sleeve
- 165-63352 (Ø8)
 - 165-63353 (Ø10)
 - 165-63354 (Ø12)

- Boring bar sleeve
- 165-63356 (Ø16)
 - 165-63358 (Ø20)
 - 165-63359 (Ø25)

- Boring bar sleeve
- 165-63347 (Ø16)
 - 165-63349 (Ø20)
 - 165-63350 (Ø25)

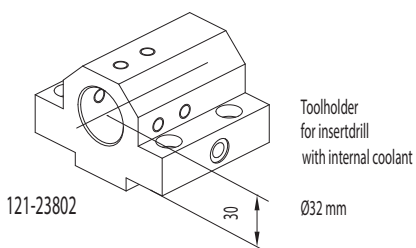

CONNECTION

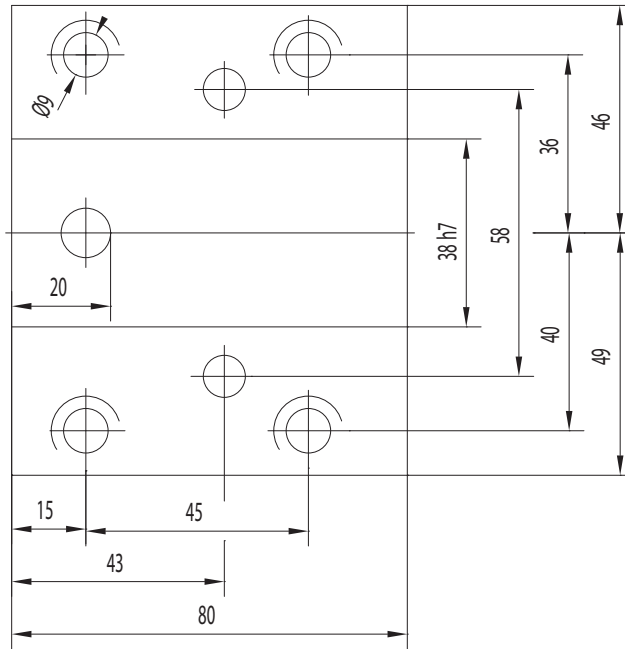

PORTAUTENSILE RADIALE - RADIAL TOOLHOLDERS

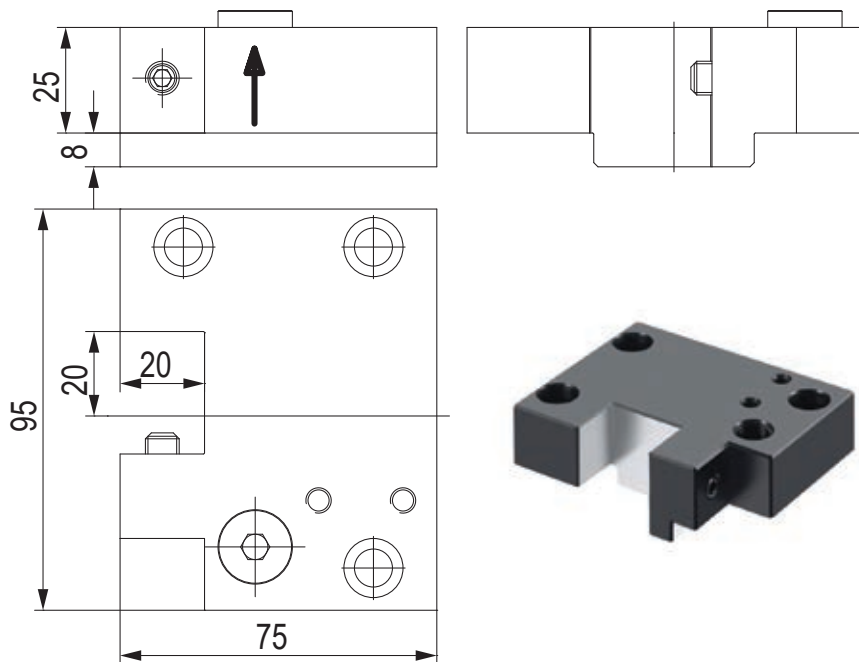

CODE N.	CLAMPING SCREW	SCREW
123-33801	811-102031	811-302110

PORTAUTENSILE RADIALE - RADIAL TOOLHOLDERS

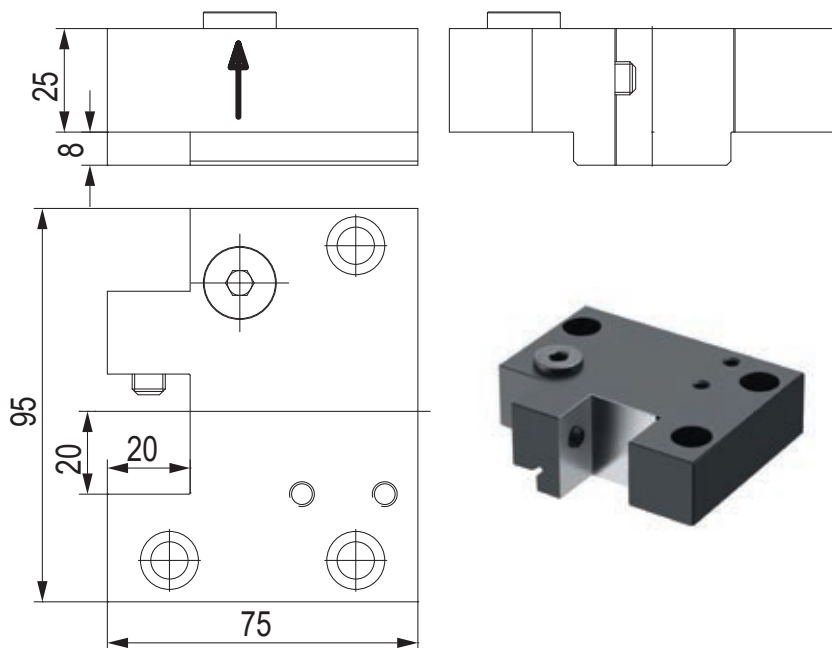

CODE N.	CLAMPING SCREW	SCREW
123-33802	811-102031	811-302110

PORTAUTENSILE PER BARENI TOOLHOLDER FOR BORING BAR

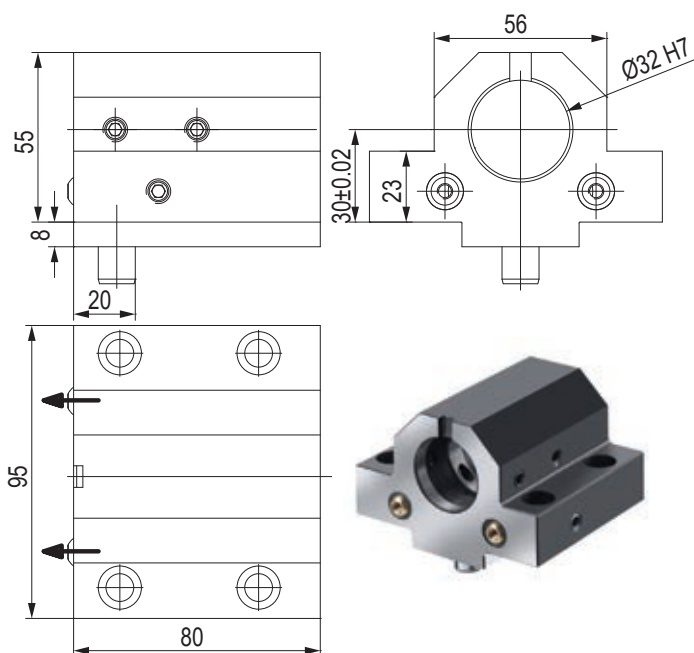

CODE N.	CLAMPING SCREW	PIN	COOLANT NOZZLE
121-23801	811-102028	815-210610	833-001080

PORTAUTENSILI PER PUNTE TOOLHOLDER FOR INSERTDRILL

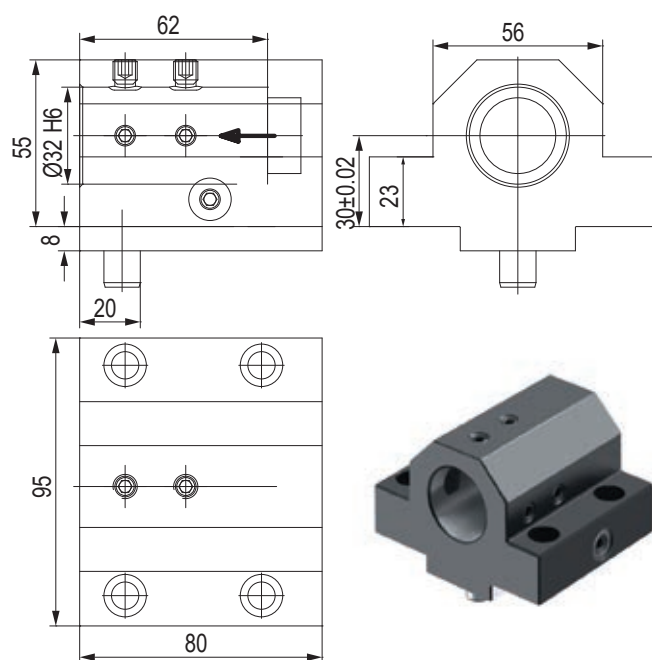

CODE N.	CLAMPING SCREW1 (M8X12)	CLAMPING SCREW2 (M8x8)	PIN
121-23802	811-102028	811-102026	815-210610

BUSSOLA PER PORTABARENI BORING BAR SLEEVE FOR TOOLHOLDER

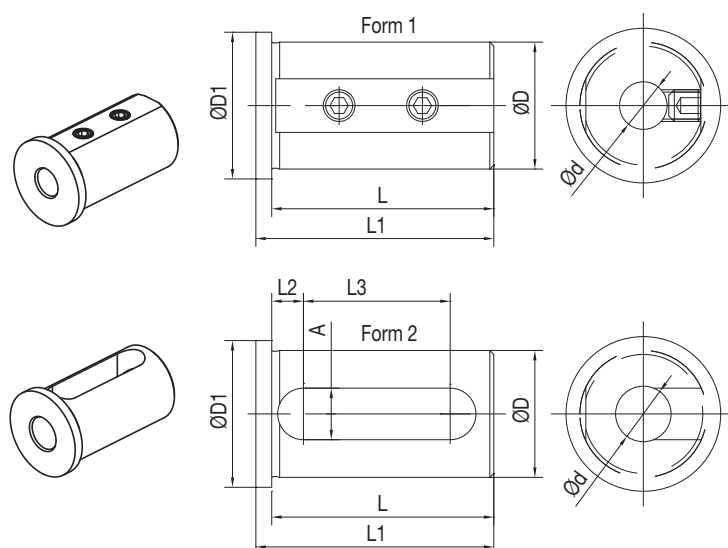

CODE N.	D	d	L	L1	L2	L3	A	D1	D1
165-63347	32	16	64	76	8,5	42	13	39	37
165-63349	32	20	64	76	8,5	42	13	39	37
165-63350	32	25	64	76	8,5	42	13	39	37
165-63356	32	16	2	56	60	8	37	13	37
165-63358	32	20	2	56	60	8	37	13	37
165-63359	32	25	2	56	60	8	37	13	37

BUSSOLA PER PORTABARENI BORING BAR SLEEVE FOR TOOLHOLDER

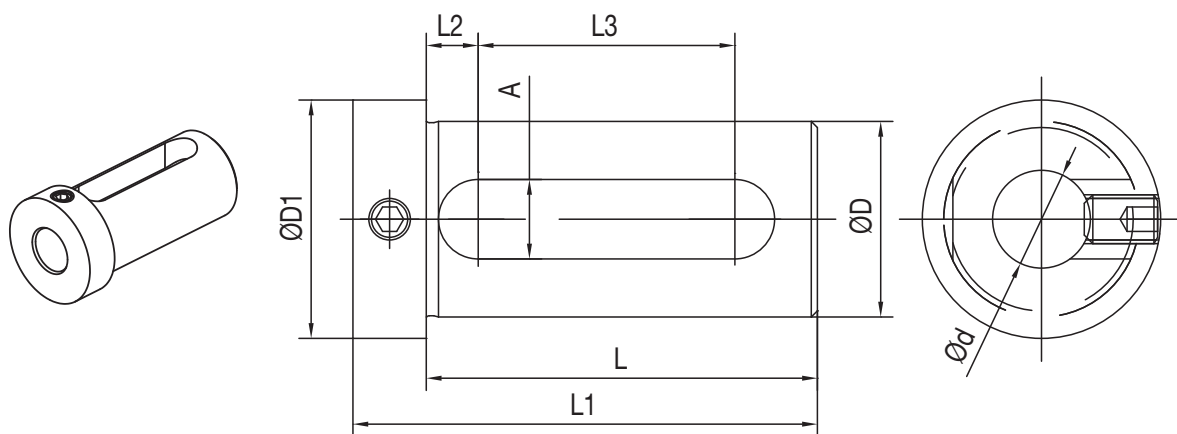

CODE N.	D	d	L	L1	L2	L3	A	D1
165-63347	32	16	64	76	8,5	42	13	39
165-63349	32	20	64	76	8,5	42	13	39
165-63350	32	25	64	76	8,5	42	13	39



MAZAK NEXUS QTN200/250

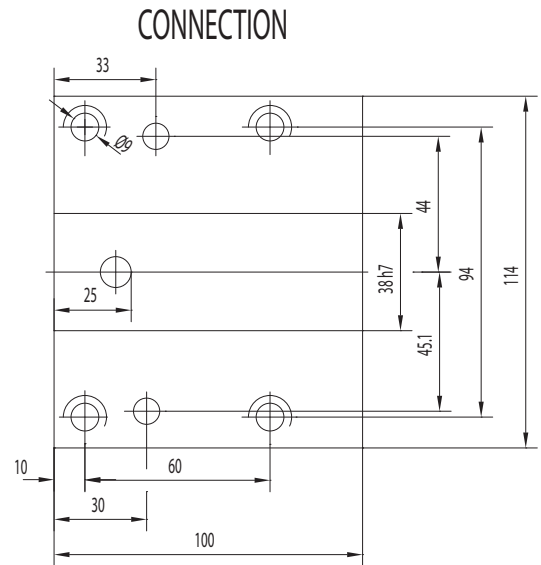
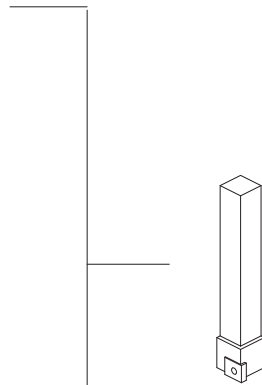
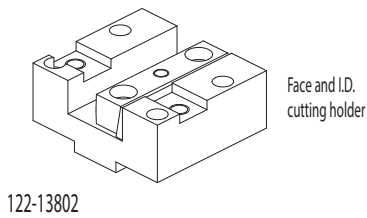
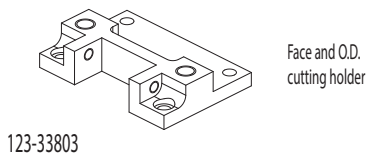

ACCESSORIES

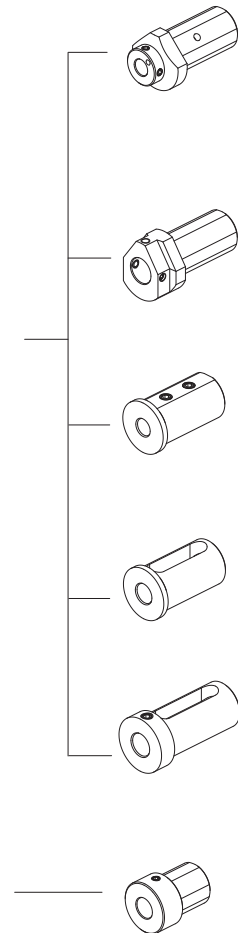
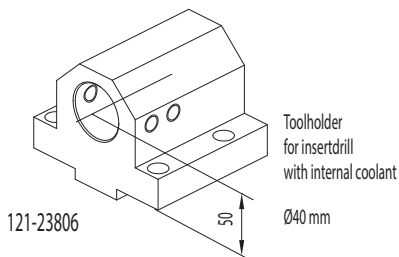
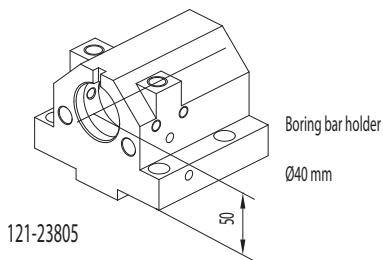

Boring bar sleeve

- 165-64114 (Ø8)
- 165-64115 (Ø10)
- 165-64116 (Ø12)
- 165-64117 (Ø16)
- 165-64118 (Ø20)

Boring bar sleeve

- 165-64119 (Ø25)
- 165-64120 (Ø32)

Boring bar sleeve

- 165-64247 (Ø8)
- 165-64248 (Ø10)
- 165-64249 (Ø12)

Boring bar sleeve

- 165-64251 (Ø16)
- 165-64253 (Ø20)
- 165-64254 (Å25)
- 165-64255 (Å32)

Boring bar sleeve

- 165-64241 (Ø16)
- 165-64243 (Ø20)
- 165-64244 (Ø25)
- 165-64245 (Ø32)

Throw-away drill socket

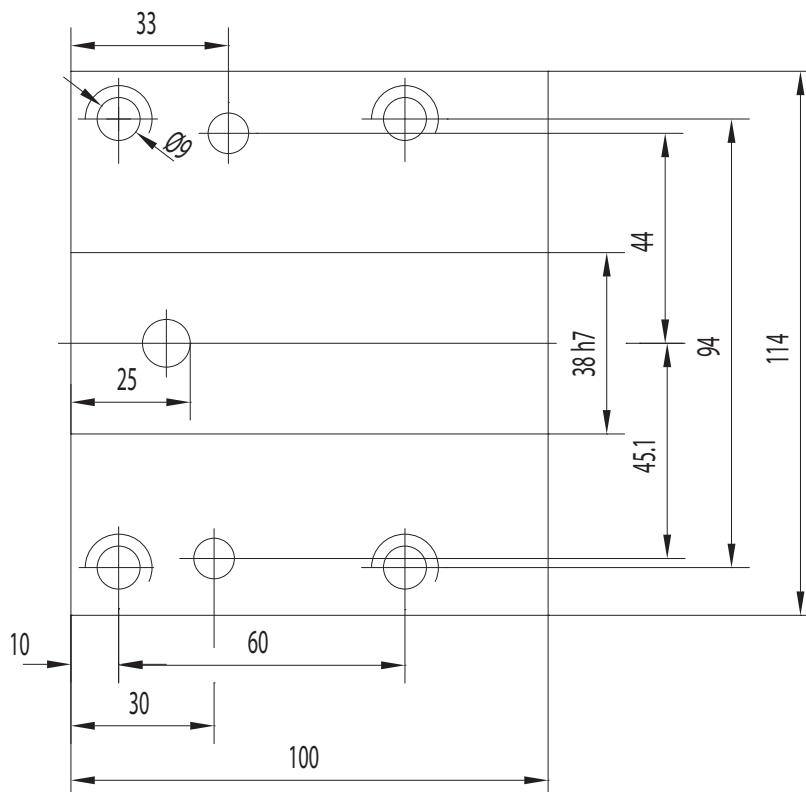

- 165-64121 (Ø20 mm)
- 165-64122 (Ø25 mm)
- 165-64123 (Ø32 mm)

CONNECTION

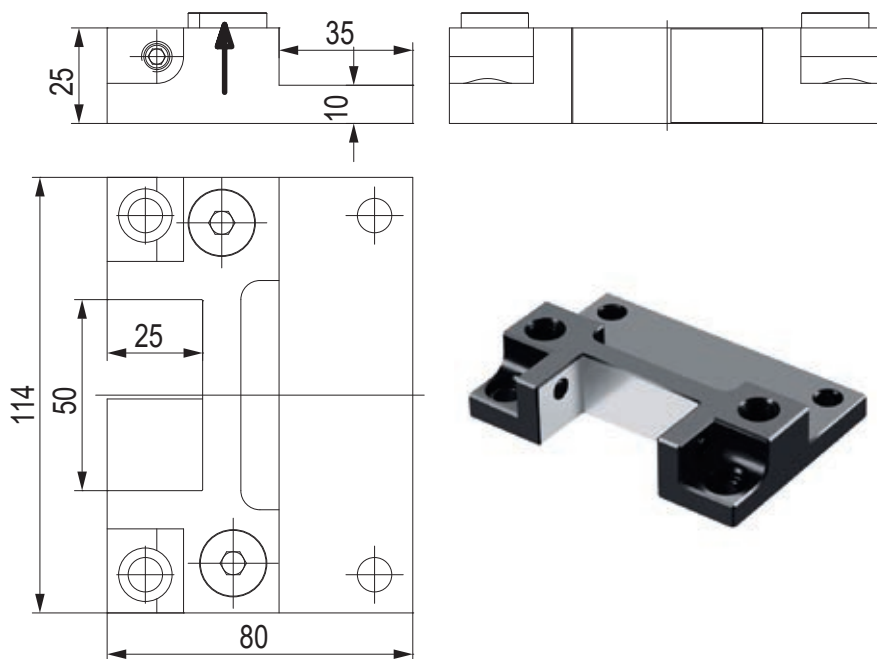

PORTAUTENSILE RADIALE - RADIAL TOOLHOLDERS

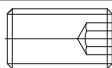

CODE N.	CLAMPING SCREW	CLAMPING PLATE	SCREW
123-33803			
123-33803	811-102027	832-002170	811-302110

PORTAUTENSILE ASSIALE - AXIAL TOOLHOLDERS

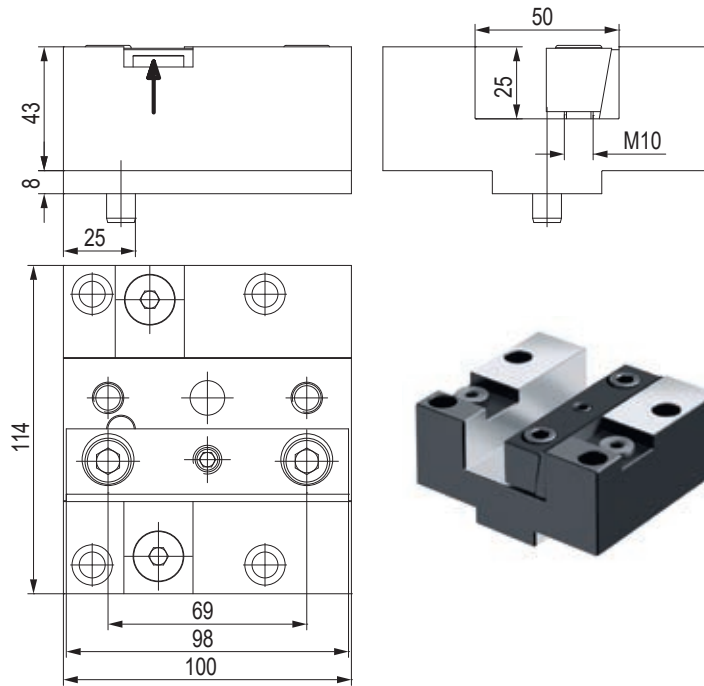

CODE N.	CLAMPING PLATE	PIN	SCREW
122-13802	832-007220	815-210620	811-302110

PORTAUTENSILE PER BARENI Ø40 TOOLHOLDER FOR BORING BAR Ø40

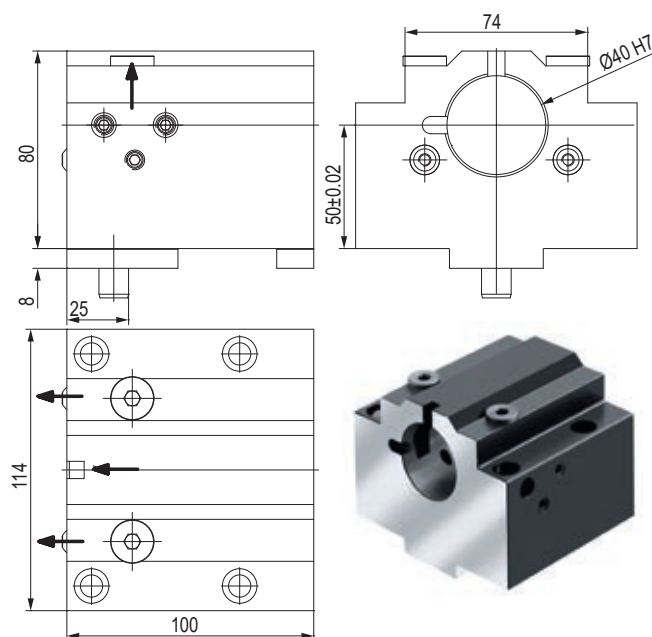

CODE N.	CLAMPING SCREW	PIN	SCREW	COOLANT NOZZLE
121-23805	811-102030	815-210610	811-302110	833-001080

PORTABARENO PER PUNTE TOOLHOLDER FOR INSERT DRILL

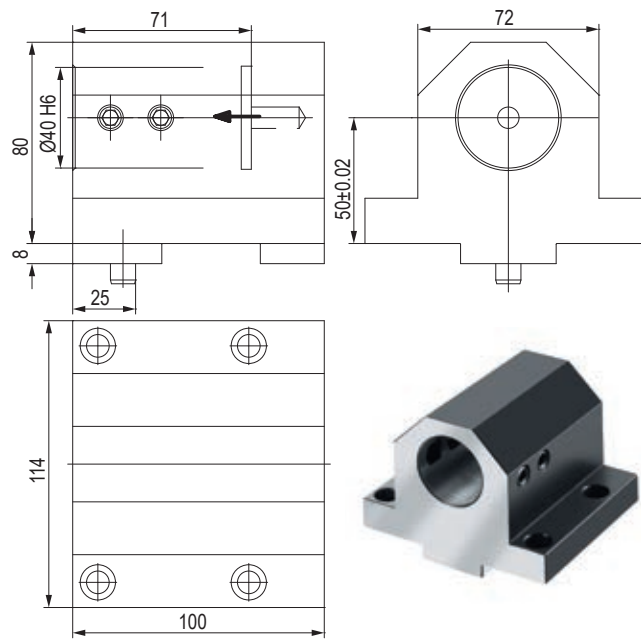

CODE N.	CLAMPING SCREW	PIN
121-23806	811-102043	815-210620

BUSSOLA PER PORTABARENO BORING BAR SLEEVE

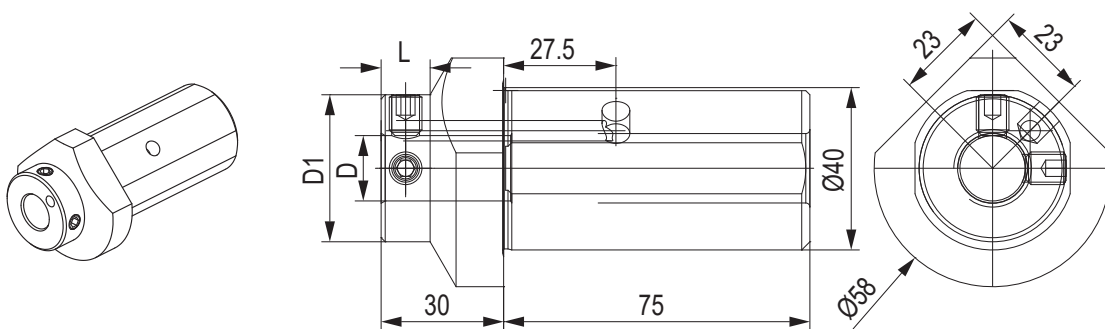

CODE N.	Ø	D	D1	L	SCREW
165-64114	40	8	36	12	811-102020
165-64115	40	10	36	12	811-102020
165-64116	40	12	36	12	811-102028
165-64117	40	16	36	12	811-102027
165-64118	40	20	58	-	811-102030

BUSSOLA PER PORTABARENO BORING BAR SLEEVE

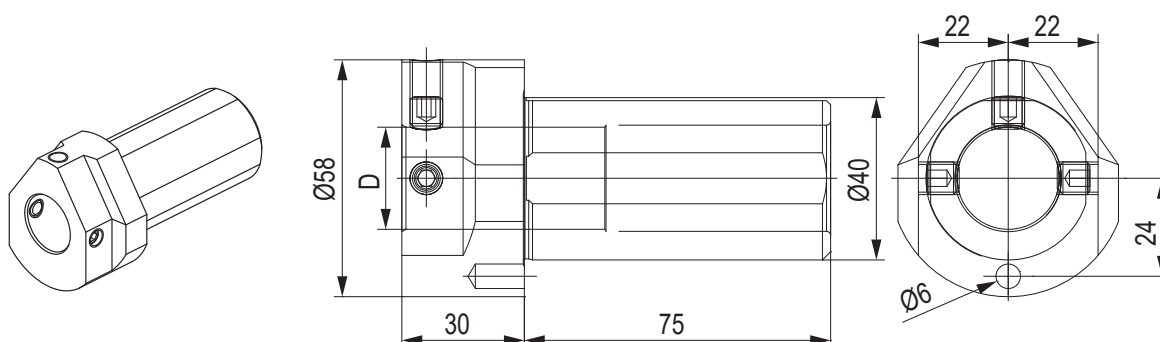

CODE N.	Ø	D	SCREW
165-64119	40	25	811-102026
165-64120	40	32	811-102026

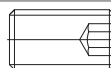

BUSSOLA PER PORTABARENO BORING BAR SLEEVE

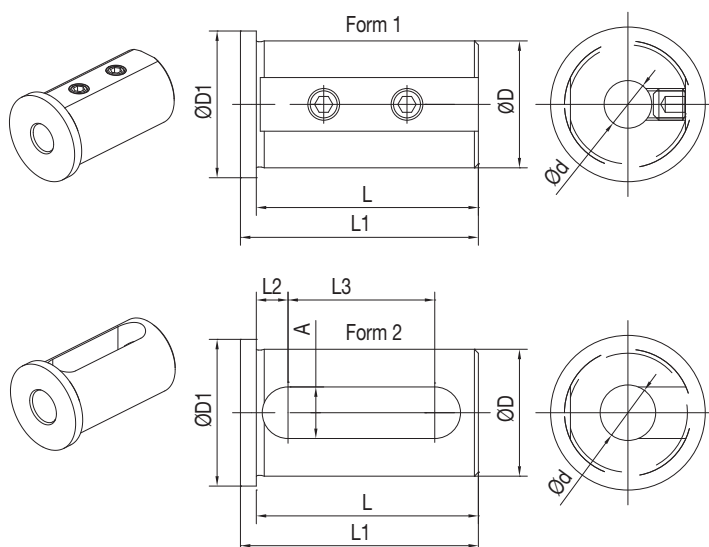

CODE N.	D	d	FORM	L	L1	L2	L3	A	D1
165-64247	40	8	1	71	75	-	-	-	45
165-64248	40	10	1	71	75	-	-	-	45
165-64249	40	12	1	71	75	-	-	-	45
165-64251	40	16	2	71	75	8	52	13	45
165-64253	40	20	2	71	75	8	52	13	45
165-64254	40	25	2	71	75	8	52	13	45
165-64255	40	32	2	71	75	8	52	13	45

BUSSOLA PER PORTABARENO BORING BAR SLEEVE

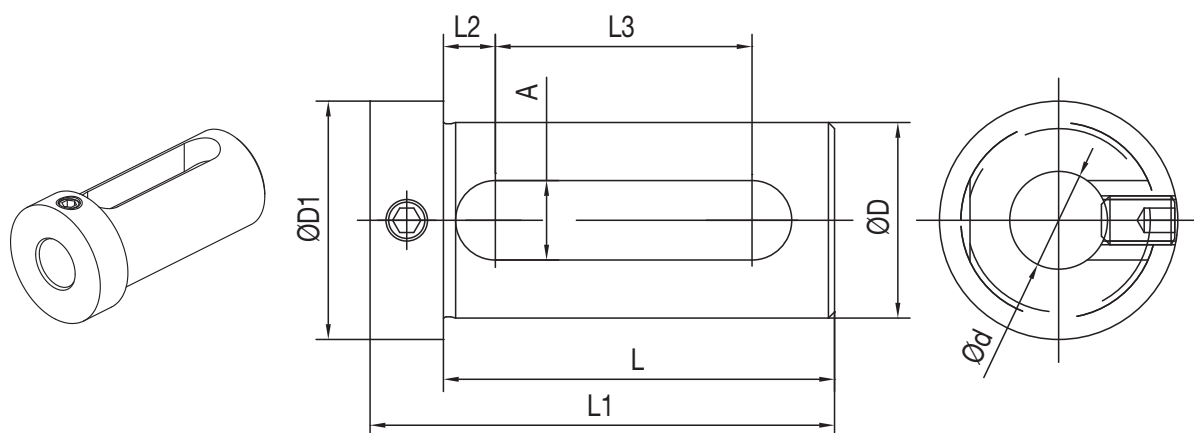

CODE N.	D	d	L	L1	L2	L3	A	D1
165-64241	40	16	74	88	9	51	14	48
165-64243	40	20	74	88	9	51	14	48
165-64244	40	25	74	88	9	51	14	48
165-64245	40	32	74	88	9	51	14	48

BUSSOLA PER PORTABARENO BORING BAR SLEEVE

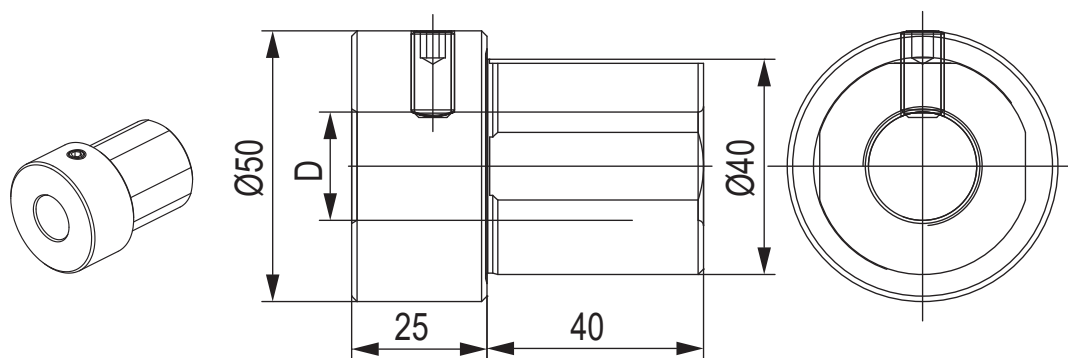

CODE N.	Ø	D	SCREW
165-64121	40	20	811-102029
165-64122	40	25	811-102028
165-64123	40	32	811-102027

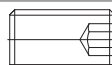

MAZAK SQT

SQT 15, SQT 18 M / MS - 12 Stations
SQT 200, SQT 250 M / MS - 12 Stations

MAZAK QTN
(VDI40)

QTN 200, QTN 250 M / MB / MS / MY / MSY - 12 Stations

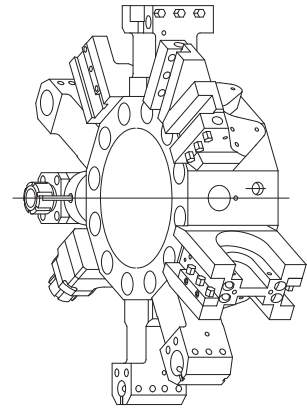
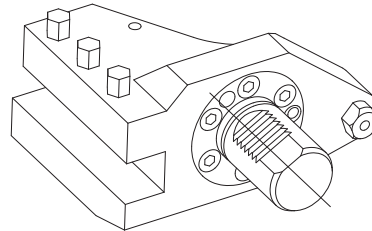
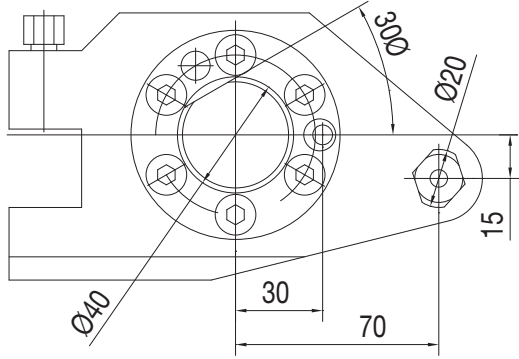

ACCESSORIES

Qualified tool
25x25 mm

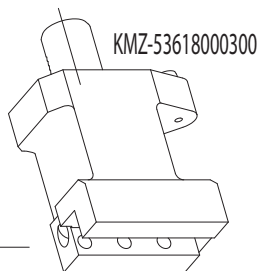
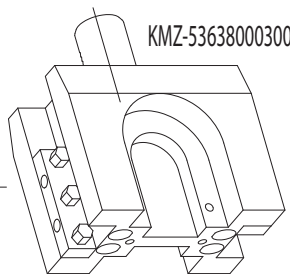
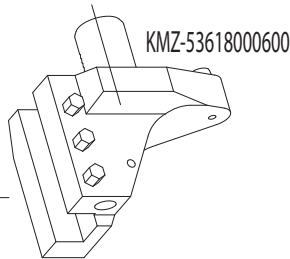
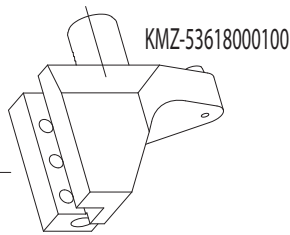
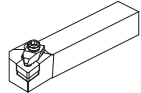

Boring bar sleeve

- 165-64114 (Ø8)
- 165-64115 (Ø10)
- 165-64116 (Ø12)
- 165-64117 (Ø16)
- 165-64118 (Ø20)

Boring bar sleeve

- 165-64119 (Ø25)
- 165-64120 (Ø32)

Boring bar sleeve

- 165-64247 (Ø8)
- 165-64248 (Ø10)
- 165-64249 (Ø12)

Boring bar sleeve

- 165-64251 (Ø16)
- 165-64253 (Ø20)
- 165-64254 (Ø25)
- 165-64255 (Ø32)

Boring bar sleeve

- 165-64241 (Ø16)
- 165-64243 (Ø20)
- 165-64244 (Ø25)
- 165-64245 (Ø32)

Throw-away drill socket

- 165-64121 (Ø20)
- 165-64122 (Ø25)
- 165-64123 (Ø32)

Cut-off tool
32 mm

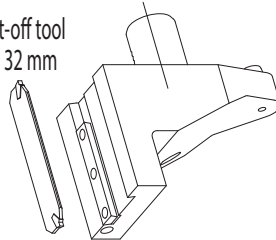

KMZ-53618000400

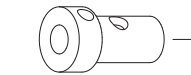
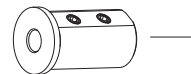
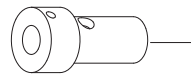
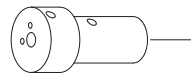

ER32
COLLET

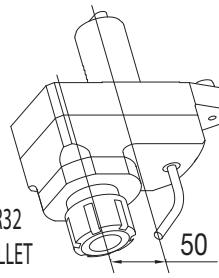

116-54019

KMZ-53208005100

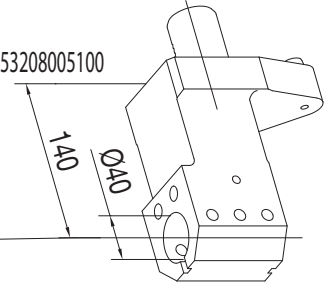

KMZ-53638000400

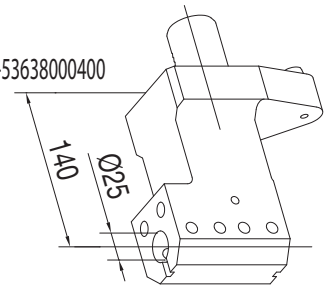

KMZ-53208005200

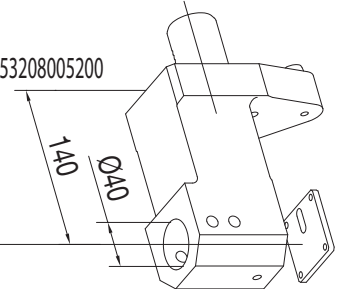

ER32
COLLET

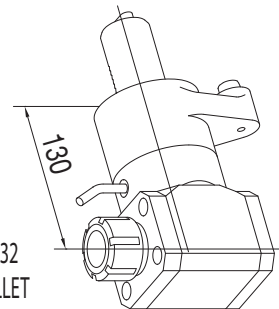

116-54020

MAZAK
(BMT68)

QTC/QTU 100-350 M/MY/MS/MSY
QT/QTS 100-250 M/MY//MS/MSY
QT 200-250 M/MY//MS/MSY (16D)

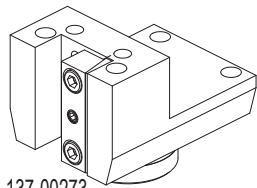

Face and O.D. cutting holder

137-00273

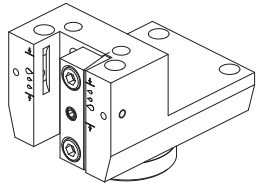

Face and O.D. cutting holder

137-00273-IC I.Coolant

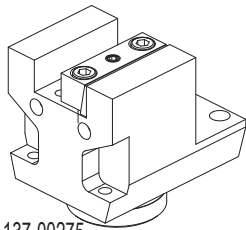

Face and I.D. cutting holder

137-00275

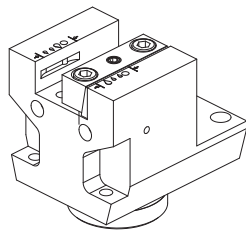

Face and I.D. cutting holder

137-00275-IC I.Coolant

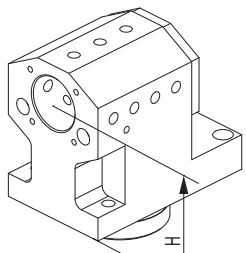

Combi toolholder for boring bar and insertdrill
Ø40 mm

137-00277 (H=90 mm)
137-00278 (H=95 mm)

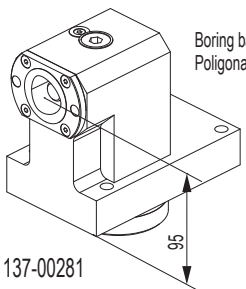

Boring bar holder
Polygonal C40

137-00281

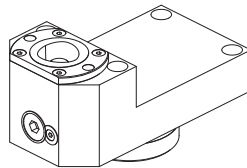

Face and O.D. cutting holder
Polygonal C40

137-00282



Qualified tool
25x25 mm

CONNECTION

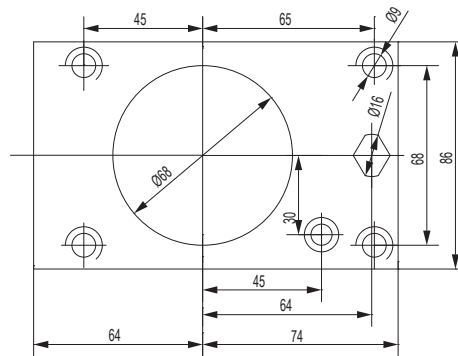

Driven tools

FAST-IN

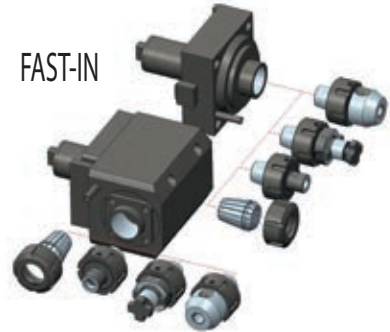

124-06805
124-06806 i.coolant



124-06807
124-06808 i.coolant

ACCESSORIES

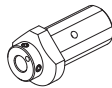

Boring bar sleeve

- 165-64114 (Ø8)
- 165-64115 (Ø10)
- 165-64116 (Ø12)
- 165-64117 (Ø16)
- 165-64118 (Ø20)

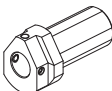

Boring bar sleeve

- 165-64119 (Ø25)
- 165-64120 (Ø32)

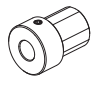

Throw-away drill socket

- 165-64121 (Ø20)
- 165-64122 (Ø25)
- 165-64123 (Ø32)

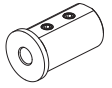

Boring bar sleeve

- 165-64247 (Ø8)
- 165-64248 (Ø10)
- 165-64249 (Ø12)

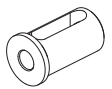

Boring bar sleeve

- 165-64251 (Ø16)
- 165-64253 (Ø20)
- 165-64254 (Ø25)
- 165-64255 (Ø32)

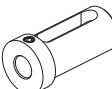

Boring bar sleeve

- 165-64241 (Ø16)
- 165-64243 (Ø20)
- 165-64244 (Ø25)
- 165-64245 (Ø32)

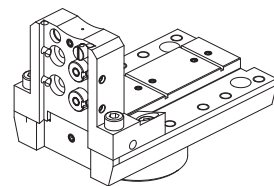

Cut-off holder

137-00279

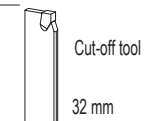

Cut-off tool
32 mm

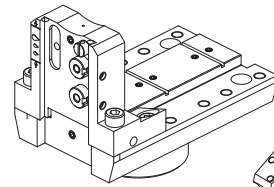

137-00279-IC I.Coolant

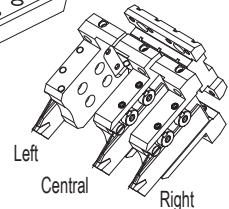

Left
Central
Right

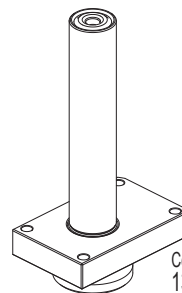

Control pin
137-00201

Protection cover
137-00272

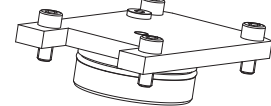



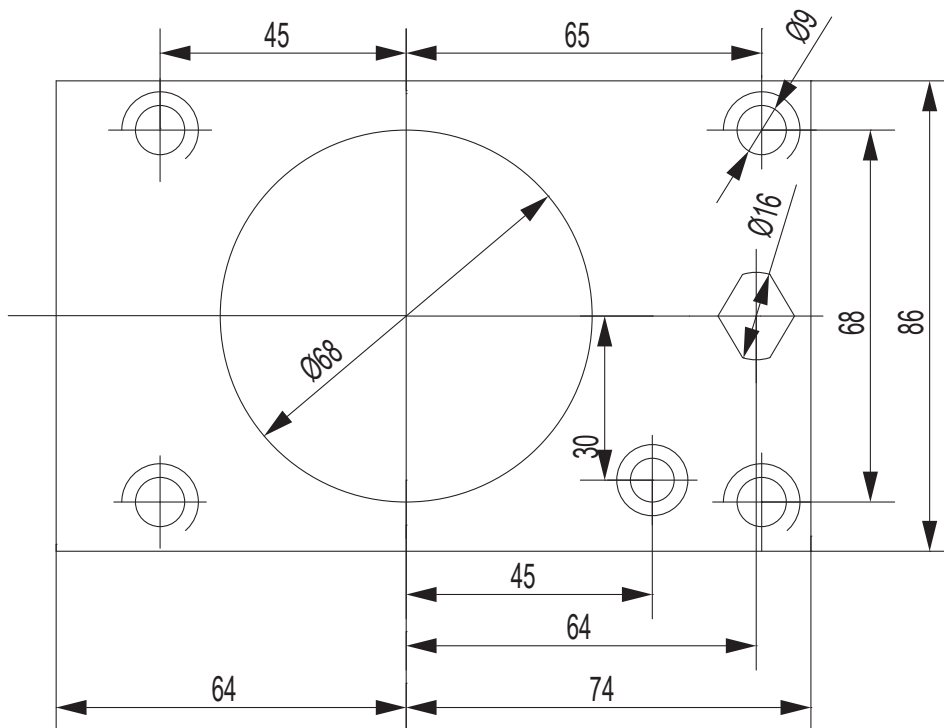



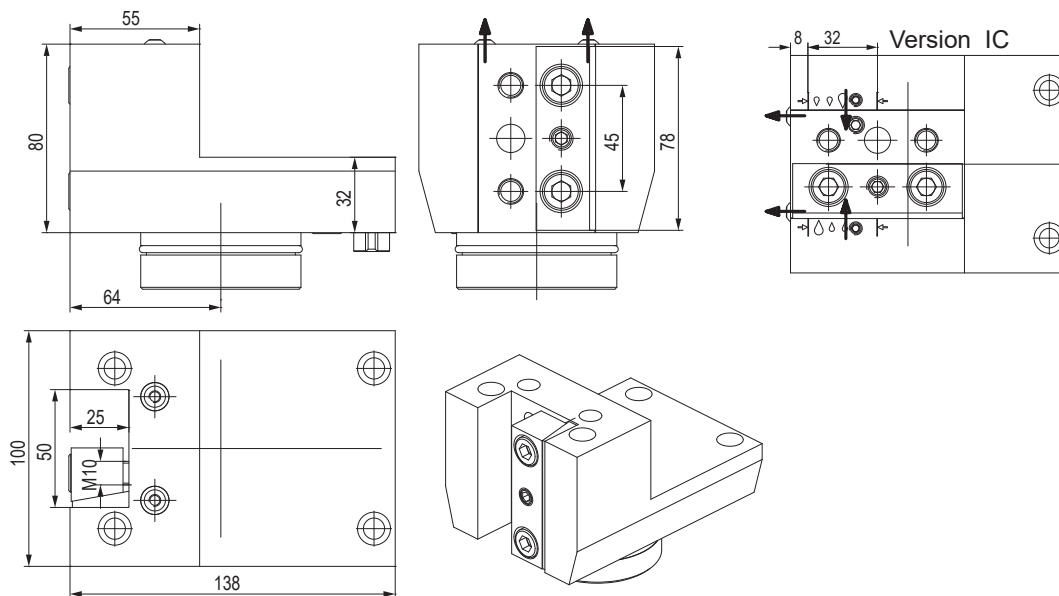

CONNECTION

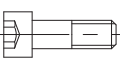

PORTAUTENSILE RADIALE - RADIAL TOOLHOLDERS



CODE N.	INTERNAL COOLANT	CLAMPING PLATE	PIN	COOLANT NOZZLE	CENTRAL PIN	SCREW FOR PIN	O RING FOR PIN (62X3)	O RING FOR PIN (54X3)	O RING FOR COOLANT (9X2)
137-00273	NO								
137-00273-IC	YES	832-007470	832-008064	833-001080	832-020711	811-101031	823-101124	823-101077	823-101015
		832-007470	832-008064	833-001080	832-020711	811-101031	823-101124	823-101077	823-101015

PORTAUTENSILE ASSIALE - AXIAL TOOLHOLDERS

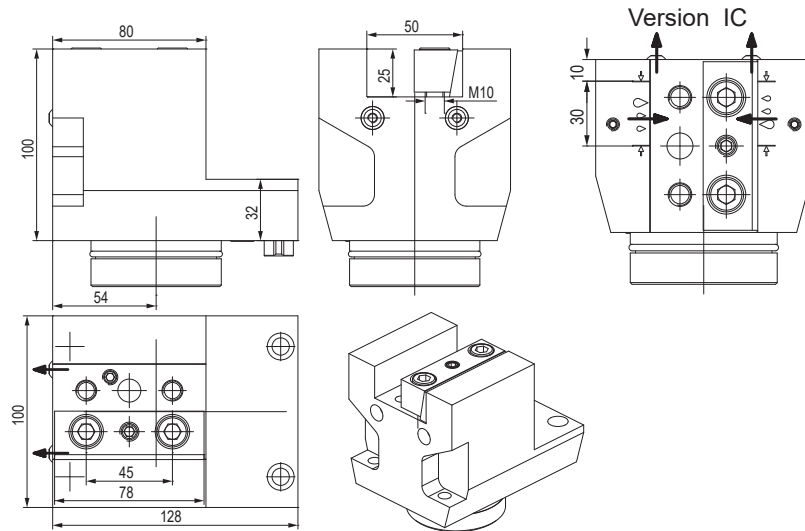

CODE N.	INTERNAL COOLANT	CLAMPING PLATE	PIN	COOLANT NOZZLE	CENTRAL PIN	SCREW FOR PIN	O RING FOR PIN (62X3)	O RING FOR PIN (54X3)	O RING FOR COOLANT (9X2)
137-00275	NO	832-007470	832-008064	833-001080	832-020711	811-101031	823-101124	823-101077	823-101015
137-00275-IC	YES	832-007470	832-008064	833-001080	832-020711	811-101031	823-101124	823-101077	823-101015

PORTALAMA - CUT-OFF HOLDERS

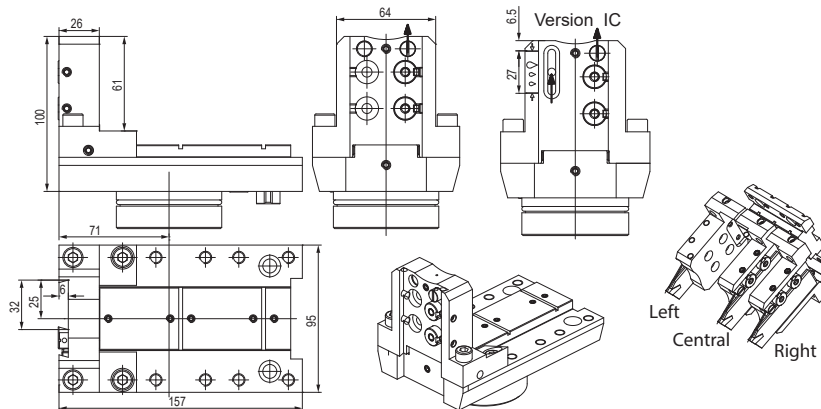

CODE N.	COOLANT NOZZLE	O RING FOR COOLANT NOZZLE	O RING FOR BODY	O RING FOR INT. COOLANT	PIN
137-00279	833-001490	823-101058	823-101061	-	832-008064
137-00279-IC	833-001490	823-101058	823-101061	823-201140	832-008064

CODE N.	SHIM PLATE	SCREW FOR PLATE	CLAMPING PIN	SPRING	CLAMPING SCREW	SCREW
137-00279	832-014448	811-108037	832-014450	824-300012	811-101029	811-104013
137-00279-IC	832-014448	811-108037	832-014450	824-300012	811-101029	811-104013

CODE N.	CENTRAL PIN	SCREW FOR PIN	O RING FOR PIN (62X3)	O RING FOR PIN (54X3)	O RING FOR COOLANT (9X2)
137-00279	832-020711	811-101031	823-101124	823-101077	823-101015
137-00279-IC	832-020711	811-101031	823-101124	823-101077	823-101015

PORTAUTENSILE COMBINATO PER BARENI E PUNTE A INSERTI COMBI TOOLHOLDER FOR BORING BAR AND INSERTDRILL

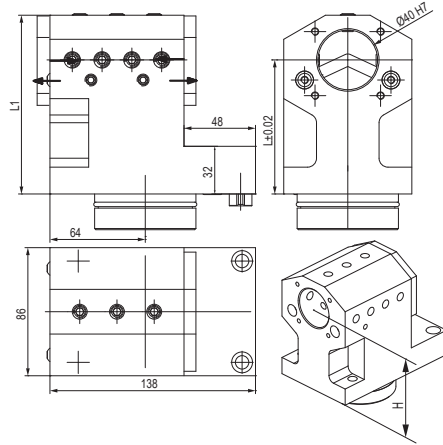

CODE N.	L	L1	CLAMPING SCREW1 (M10X20)	CLAMPING SCREW1 (M10X12)	PIN	COOLANT NOZZLE	COVER FOR INTERNAL COOLANT	SCREW FOR COVER
137-00277	90	120	811-102038	811-102036	832-008064	833-001080	832-003403	811-101016
137-00278	95	125	811-102038	811-102036	832-008064	833-001080	832-003403	811-101016

CODE N.	CENTRAL PIN	SCREW FOR PIN	O RING FOR PIN (62X3)	O RING FOR PIN (54X3)	O RING FOR COOLANT (9X2)
137-00277	832-020711	811-101031	823-101124	823-101077	823-101015
137-00278	832-020711	811-101031	823-101124	823-101077	823-101015

PORTAUTENSILE CON USCITA POLIGONALE POLIGONAL TOOLHOLDERS

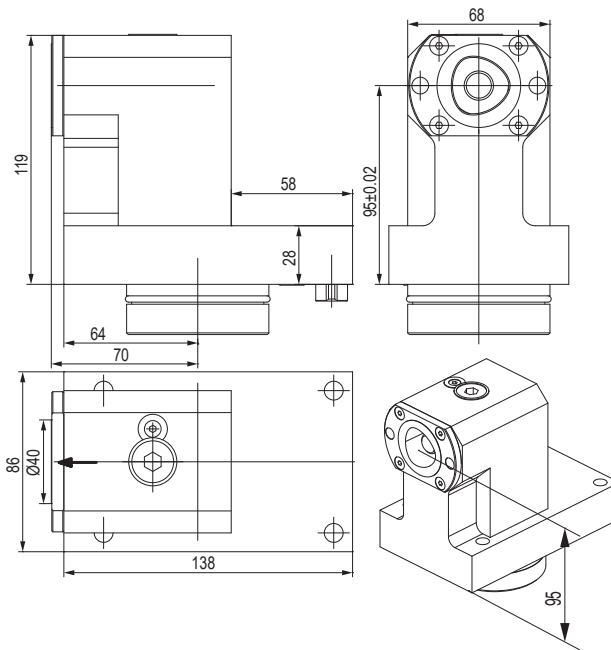

CODE N.	CAPTO	CLAMPING UNIT	PIN	CENTRAL PIN	SCREW FOR PIN	O RING FOR PIN (62X3)	O RING FOR PIN (54X3)	O RING FOR COOLANT (9X2)
137-00281	C40	CXC40-10	832-008064	832-020711	811-101031	823-101124	823-101077	823-101015

PORTAUTENSILE CON USCITA POLIGONALE POLIGONAL TOOLHOLDERS

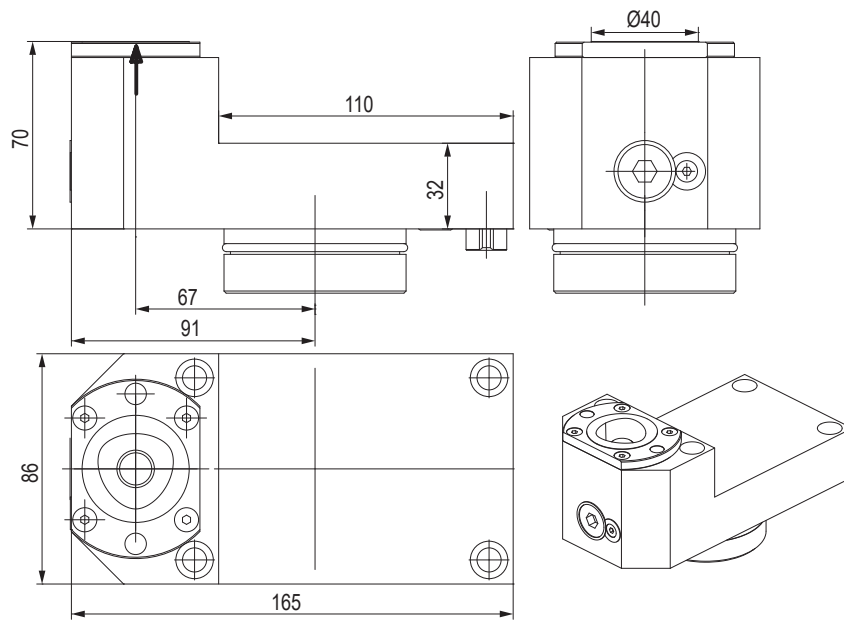

CODE N.	CAPTO	CLAMPING UNIT	PIN	CENTRAL PIN	SCREW FOR PIN	O RING FOR PIN (62X3)	O RING FOR PIN (54X3)	O RING FOR COOLANT (9X2)
137-00282	C40	CXC40-10	832-008064	832-020711	811-101031	823-101124	823-101077	823-101015

PORTAUTENSILE MOTORIZZATO ASSIALE STRAIGHT DRILLING AND MILLING HEAD

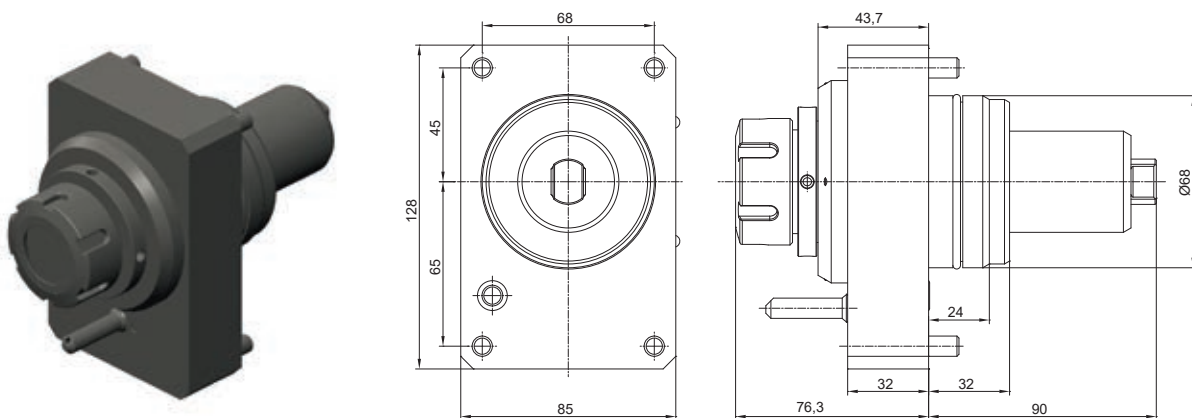

CODE N.	ER	MAX SPEED (Rpm)	I	MAX. TORQUE (Nm)	INTERNAL COOLING	P Bar
124-06805	ER32	12000	1:1	70	no	-
124-06806	ER32	12000	1:1	70	yes	20

PORTAUTENSILE MOTORIZZATO RADIALE ANGULAR DRILLING AND MILLING HEAD

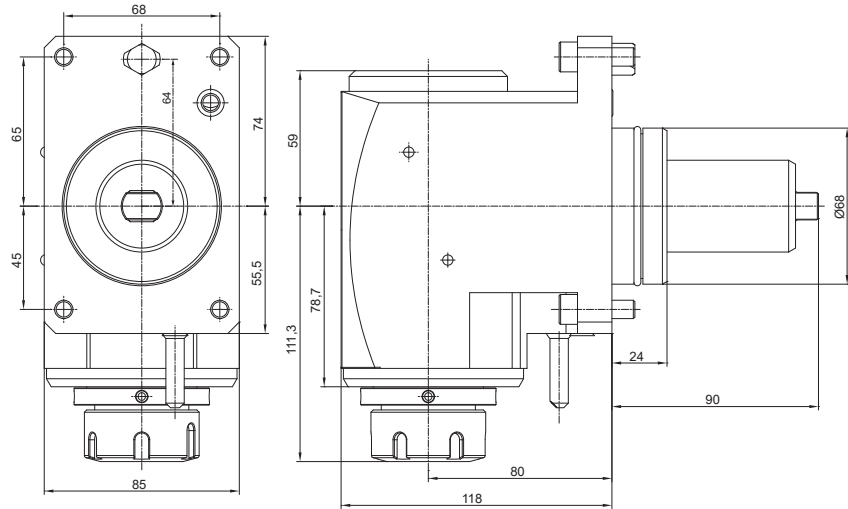

CODE N.	ER	MAX SPEED (Rpm)	I	MAX. TORQUE (Nm)	INTERNAL COOLING	P Bar
124-06807	ER32	6000	1:1	70	no	-
124-06808	ER32	6000	1:1	70	yes	20

BARRA DI CONTROLLO - CONTROL PIN

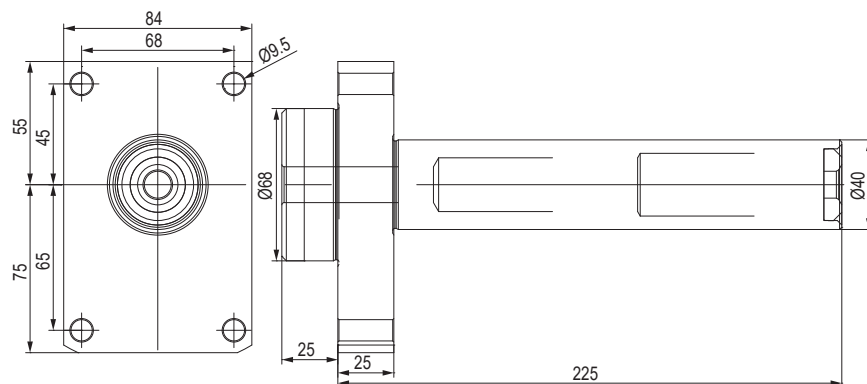
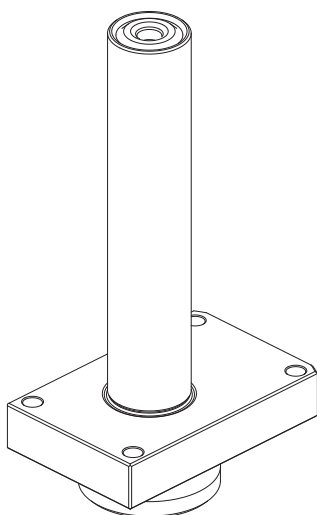

CODE N.

137-00201

TAPPO DI PROTEZIONE - PROTECTION COVER

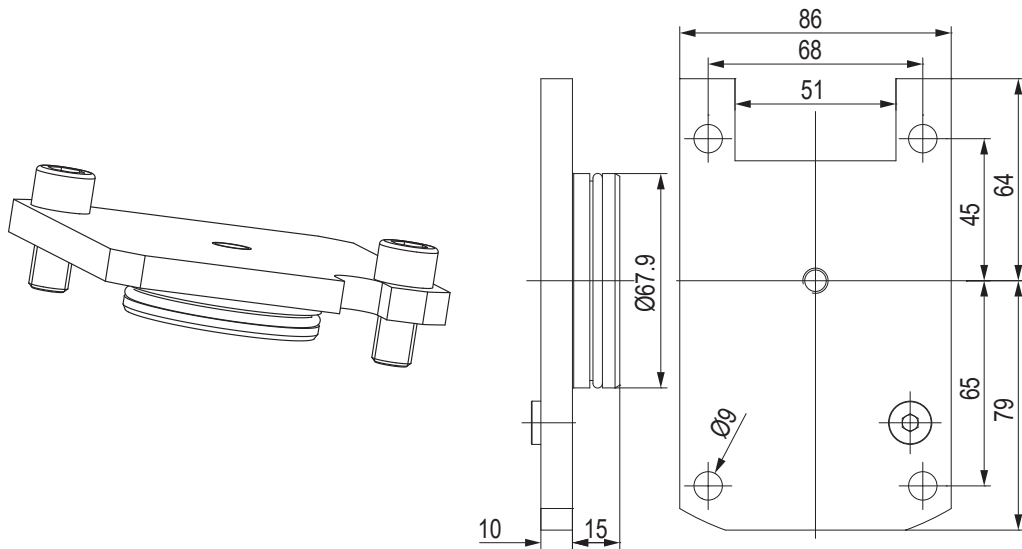

CODE N.	O RING	SCREW
137-00272	823-101124	811-302106

BUSSOLA PER PORTABARENI BORING BAR SLEEVE FOR TOOLHOLDER

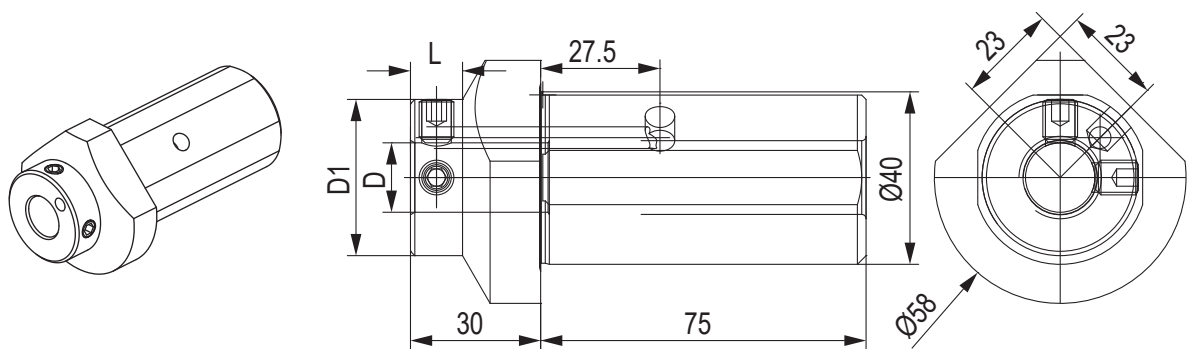

CODE N.	Ø	D	D1	L	SCREW
165-64114	40	8	36	12	811-102020
165-64115	40	10	36	12	811-102020
165-64116	40	12	36	12	811-102028
165-64117	40	16	36	12	811-102027
165-64118	40	20	58	-	811-102030

BUSSOLA PER PORTABARENI BORING BAR SLEEVE FOR TOOLHOLDER

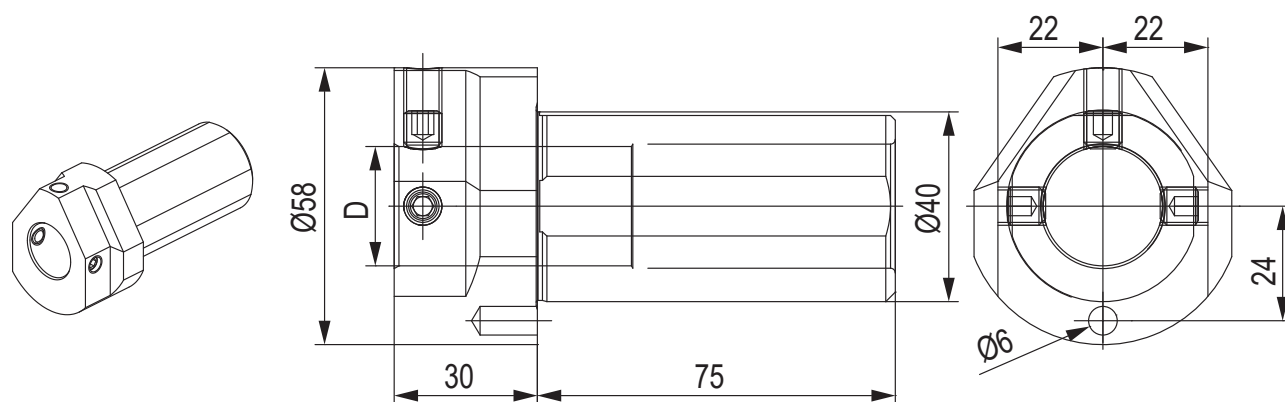

CODE N.	Ø	D	SCREW
165-64119	40	25	811-102026
165-64120	40	32	811-102026

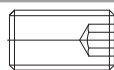

BUSSOLA PER PORTABARENI THROW-AWAY DRILL SOCKET FOR TOOLHOLDER

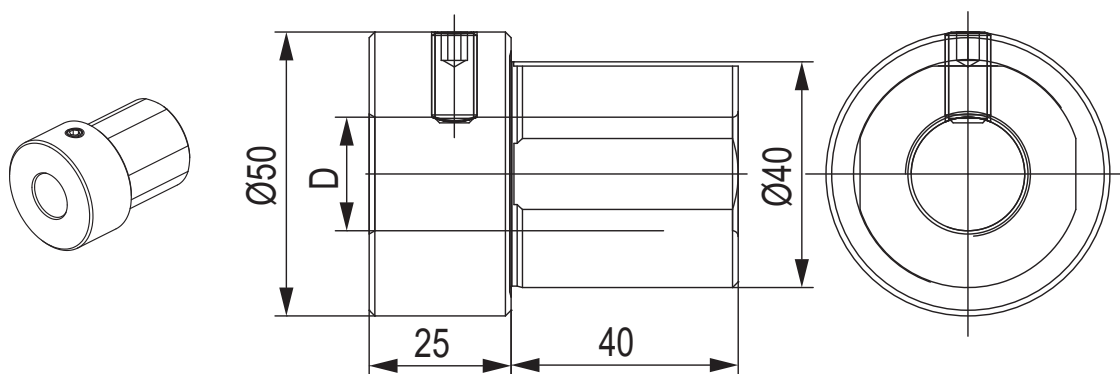

CODE N.	Ø	D	SCREW
165-64121	40	20	811-102029
165-64122	40	25	811-102028
165-64123	40	32	811-102027

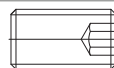

BUSSOLA PER PORTABARENI BORING BAR SLEEVE FOR TOOLHOLDER

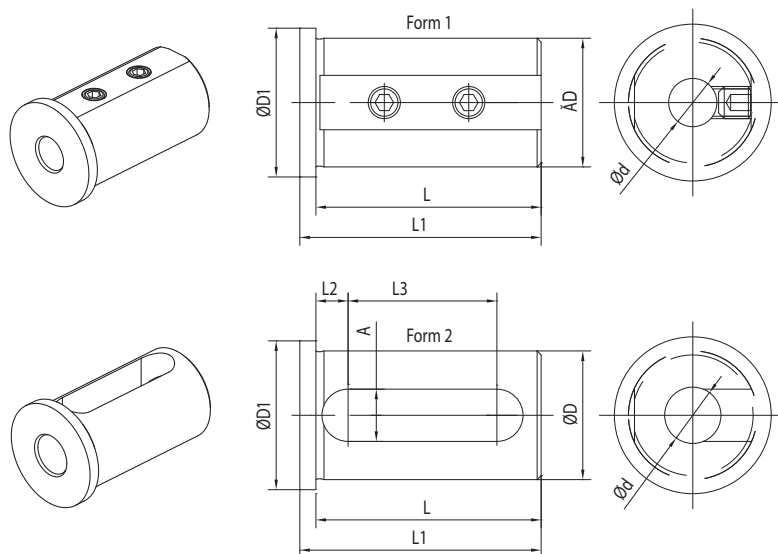

CODE N.	D	d	FORM	L	L1	L2	L3	A	D1
165-64247	40	8	1	71	75	-	-	-	45
165-64248	40	10	1	71	75	-	-	-	45
165-64249	40	12	1	71	75	-	-	-	45
165-64251	40	16	2	71	75	8	52	13	45
165-64253	40	20	2	71	75	8	52	13	45
165-64254	40	25	2	71	75	8	52	13	45
165-64255	40	32	2	71	75	8	52	13	45

BUSSOLA PER PORTABARENI BORING BAR SLEEVE FOR TOOLHOLDER

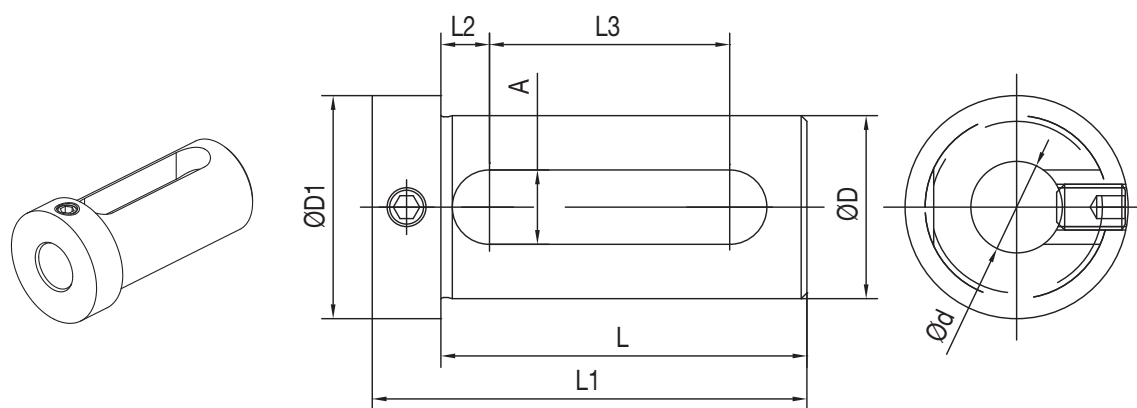

CODE N.	D	d	L	L1	L2	L3	A	D1
165-64241	40	16	74	88	9	51	14	48
165-64243	40	20	74	88	9	51	14	48
165-64244	40	25	74	88	9	51	14	48
165-64245	40	32	74	88	9	51	14	48