

**RICAMBI E ACCESSORI per Std & StandardFLEX
SPARE PARTS and ACCESSORIES for Std & StandardFLEX**

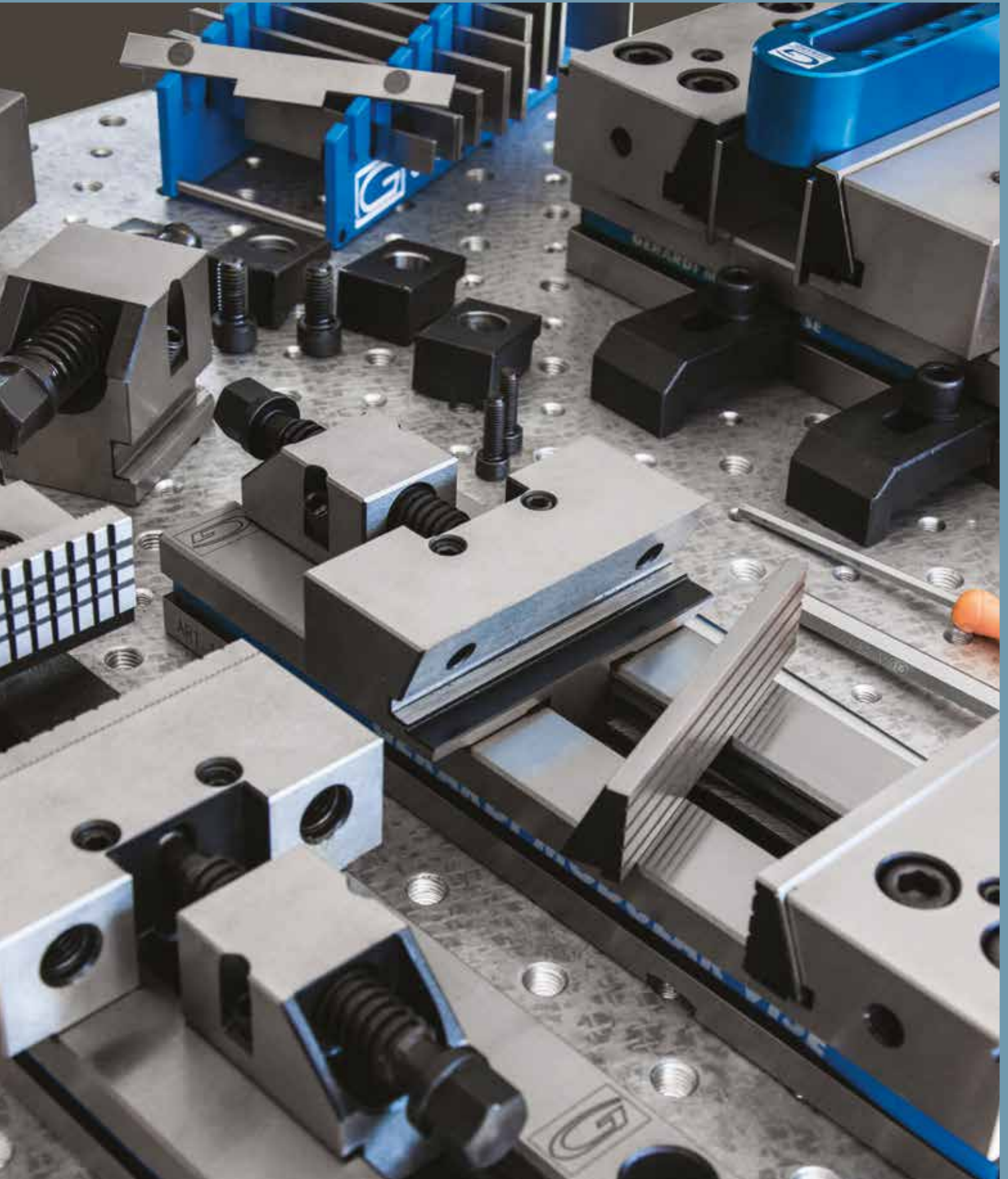

INDICE - INDEX

Art.	Pag 4.	Art.	Pag 4.	Art.	Pag 4.	Art.	Pag 4.	Art.	Pag 4.	Art.	Pag 4.
105	27	215	19	270A	47	316	26	391A/2	39	407	38
120	8	217	20	267	49	317	22	391A/3	39	407A	39
120A	16	218	20	270B	47	318	26	391A/4	39	407B	40
121	8	224	19	271	36	319	26	391B	43	407C	42
123	8	225	19	271D	36	320	18	391B/2	43	407D	43
123A	16	220 G01	13	272	52	320A	18	391B/3	43	407E	44
124	8	220 G02	13	272A	52	321	26	391B/4	43	410	32
126	8	220 G11	13	282	32	322	26	391C/2	43	420	27
126A	16	230	9	283	36	323	26	391C/3	43	430	27
127	8	230B	17	284	33	324	26	391C/4	43	431	24
127A	16	230C	17	285	37	325	31	392	40	440	24
128	8	230D	17	285A	37	355	32	392/2	40	502	49
129	8	230E	17 - 18	285B	37	356	32	392/3	40	503	49
132	24	230F	17	285C	37	357	31	392/4	40	505	47
133	24	230G	17	285D	37	360	32	392A/2	40	569	37
134	24	230H	17	285E	37	361	32	392A/3	40	569A	37
135	24	230M	17	285F	37	362	24	392A/4	40	569B	37
140	10	230S	9	285G	37	365	27	392B	44	569C	37
141	10	231	9	285H	37	366	27	392B/2	44	569D	37
143	10	231S	9	286	33	367	27	392B/3	44	569E	37
144	10	232	9	287	30	368	27	392B/4	44	569F	37
146	10	233	9	290	33	370	31	392C/2	44	569G	37
147	10	234	9	291	31	370A	31	392C/3	44	570	24
148	10	235	9	292	33	375	31	392C/4	44	570S	24
149	10	242	11	293	33	376	31	393	41	605 G1	18
152	20	242G	12 - 13	294	33	377	31	393D	45	605 G2	18
160	14	243G	12 - 13	295	33	380	24	394	41	605 G3	18
161	14	246G	12 - 13	296	29	381	24	394D	45	ID 03	47
163	14	247G	12 - 13	297	31	382	24	395	41	ID 04	47
164	14	242S	11	298	29	383	24	395D	45	ID 05	47
166	14	243	11	300	25	384	24	396	41	981	3
167	14	243S	11	300A	26	384	24	396B	41		
168	14	244	11	301	25	390	38	396C	45		
169	14	245	11	303	25	390/2	38	396D	45		
188	21	246	11	303A	26	390/3	38	397	41		
190	25	246T	11	304	25	390/4	38	397B	41		
192	21	247	11	306	25	390A/2	38	397C	45		
192S	21	247T	11	306A	26	390A/3	38	397D	45		
200	15	248	9	306B	26	390A/4	38	398	41		
201	15	248S	9	306C	26	390B	42	398B	41		
203	15	249	9	307	25	390B/2	42	398C	45		
204	15	249S	9	308	25	390B/3	42	398D	45		
206	15	250	9	309	25	390B/4	42	399	46		
207	15	251	9	310	23	390C	42	400	46		
208	15	252	9	311	23	390C/2	42	401	46		
209	15	253	9	312	23	390C/3	42	402	46		
210	20	254	21	313	23	390C/4	42	402/90	46		
211	20	257	33	313A	23	391	39	403	46		
212	19	258	32	313R	23	391/2	39	404	46		
213	19	260	32	314	23	391/3	39	405	31		
214	19	266	49	315	26	391/4	39	405H	46		

VALIGETTA DI CAMPIONATURA STD (Art.1) SAMPLE KIT CASE STD (Art.1)

NEW!



Art. 981

Valigetta di campionatura morsa Art.1 T.1
Sample kit case Art.1 T.1 vise

Cod.	0.98.10000

All'Interno - Inside:

	Art.132		Art.313		Art.298
	Art.133		Art.314		Art.370
	Art.138		Art.271		Art.375
	Art.147		Art.283		Art.376
	Art.212		Art.285	-	-
	Art.217		Art.297	-	-

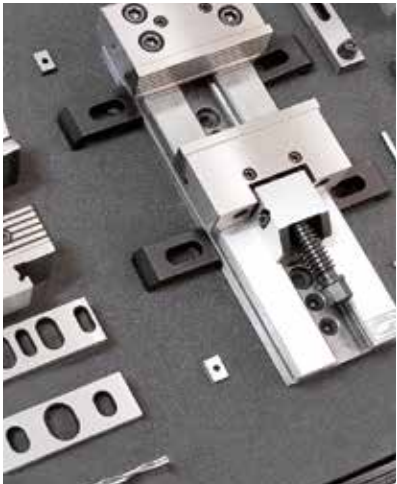

4

SIMBOLOGIA DATI TECNICI TECHNICAL DATA ICONS

GANASCE JAWS		Fissa Fixed		Mobile Movable		Intermedia Intermediate		Fissa con piastra singola Fixed with single plate		Fissa con piastra doppia Fixed with double plate		Ganasce sovrapponibili Stack Type Jaws	
		Discendente Pull down		Discendente + inserti GRIP Pull down + GRIP inserts		Lavorabile Machineable		Cambio rapido manuale Quick manual change		GRIP GRIP		Inserti GRIP Inserti GRIP	
PIASTRE GANASCE JAW PLATES		Serraggio di 1 particolare Clamping only 1 piece		Serraggio di 2 particolari Clamping 2 pieces		Montaggio sul fianco o in serie Side mounting or gang operation		Posizionamento & cambio rapido Quick change & positioning		Cubi-morsa Vise tower			
		Accessori & Ricambi Accessories & Spare Parts		Istruzioni corretto utilizzo Instruction for a proper use		Diagrammi forze di serraggio Clamping force diagrams		Accessori idraulici Hydraulic accessories		Centraline idrauliche Hydraulic Power Units Comando manuale Manual control		Centraline idrauliche Hydraulic Power Units Comando elettrico Solenoid control	
POSSIBILITÀ DI POSSIBILITY OF													
PAGINE PAGES													

RICAMBI e ACCESSORI

SPARE PARTS, ACCESSORIES

Sicuramente uno dei punti di forza del sistema modulare **GERARDI** consiste nell'ampissima scelta di componentistica ed accessori nonché nel continuo investimento e sviluppo nei più avanzati concetti e soluzioni originali.

Il programma che viene presentato nelle pagine seguenti fa parte di un sistema modulare di bloccaggio fra i più ampi e completi a livello mondiale che permette realmente di trasformare in standard ciò che sembrerebbe essere speciale (oltre 1000 articoli moltiplicati per 6 grandezze diverse).

Il segreto di tutto ciò sta proprio nella modularità del sistema che consente (con l'aggiunta di alcuni componenti) una più ampia gamma di impieghi.

ACCESSORI

Parallele, staffe, tasselli di posizionamento, arresto laterale, chiavi di bloccaggio, celle di carico.

One of the biggest point of strength of **GERARDI** modular system lies in the broadest assortment program of components and accessories and also in the continuous investment and development of the most advanced concepts and original solutions. The range of items shown in the following pages is part of a modular workholding system among the widest and complete in the world. So, any holding and clamping issue You ever have, You can solve it with Gerardi standard modular products.

The secret lies just in the modularity of the system which allows (choosing different components) a wider range of solutions.

ACCESSORIES

Parallel plates, vise holding jaws, positioning key-nuts, workstop, wrenches, loading cells.



USURA INESISTENTE

Grazie all'accurata scelta dei materiali impiegati ed allo studio dimensionale computerizzato dei componenti. **Costruzione completamente in speciali leghe di acciaio** ad alta resistenza, normalizzato, cementato e temprato con **durezza HRC 60 ±2**. Tutto ciò al fine di conferire massima rigidità, elevate prestazioni e usura inesistente. A riprova di tutto ciò assicuriamo **5 ANNI DI GARANZIA** su tutto il programma morse e organi meccanici in genere.

NO WEAR

Thanks to the manufacturing with only the most suitable materials and to the structure of the vise components (developed using computer customised softwares and the experience gained during many years spent working on the specific field). **High alloyed quality resistance steel, case hardened HRC 60 ±2**, is used in manufacturing all the Gerardi vises and accessories in order to give maximum rigidity, high performances and no wear. As evidence we give **5 YEARS WARRANTY** on all the vises and mechanical components.



CARATTERISTICHE E VANTAGGI

- USURA INESISTENTE
- RAPIDITÀ DEI SERRAGGI
- MODULARITÀ & VERSATILITÀ
- PRECISIONI ±0,02 mm
- RIGIDITÀ & SICUREZZA
- DESIGN COMPATTO E MANEGGEVOLEZZA

Si rimanda a quanto esposto a pag. 1.2 e 1.3 (morse serie STD)

TECHNICAL FEATURES AND ADVANTAGES

- NO WEAR
- QUICK CLAMPING
- MODULARITY & VERSATILITY
- HIGHEST ACCURACIES ±0,02 mm
- RIGIDITY & SAFETY
- SPACE SAVING DESIGN & HANDY

see pages 1.2 and 1.3 (STD series vises)

1 Art. 133

Prolunga per ganaschia fissa
Extension for fixed jaw

2 Art. 132

Prolunga per ganaschia mobile
Extension for movable jaw

3 Art. 212

Ganaschia mobile intermedia con doppio gradino
Intermediate movable jaws with double step

4 Art. 257

Gruppo di serraggio con mandrino a vite idraulica manuale
Hydraulic hand screw spindle clamping device

5 Art. 258

Gruppo di serraggio meccanico manuale
Mechanical clamping device manual

6 Art. 271

Ganaschia mobile intermedia con doppio gradino
Clamping device with hydraulic cylinder for automatic applications

7 Art. 131

Ganasce a squadra sovrapponibili per serraggio di particolari tondi in orizzontale
Stack type jaws fixed or movable for round workpieces horizontal clamping

8 Art. 138

Ganasce a squadra sovrapponibili fisse o mobili
Square stack-type jaws fixed or movable

9 Art. 150

Ganasce a squadra sovrapponibili per serraggio di particolari tondi in **verticale**
 Stack type jaws fixed or movable for round workpiece **vertical** clamping

10 Art. 210

Ganasce mobili guidate monoblocco per **pezzi tondi**
 Solid guided movable jaws for **round workpieces**

11 Art. 190 + 4 Art. 570

Ganasce mobili guidate monoblocco **con puntali meccanici regolabili**
 Solid guided movable jaws **with adjustable set screw**

12 Art. 188

Ganasce mobili guidate monoblocco **oleodinamiche**
Hydraulic control solid guided movable jaws

13 Art. 217

Ganasce mobili guidate monoblocco **prismatiche**
 (per serraggio pezzi piatti e tondi)
 Solid guided movable **prismatic** jaws
 (for plates & round workpieces clamping)

14 Art. 146

Ganasce mobili guidate monoblocco **con piastre piane**
 Solid guided movable jaws **with straight plates**

15 Art. 105

Base girevole ($0^\circ \pm 360^\circ$) utilizzabile per serraggi che necessitano movimenti di rotazione dell' attrezzatura sulla tavola indipendenti, permette di ottenere l' angolo desiderato velocemente e con ripetibilità centesimale.

Swivel base ($0^\circ \pm 360^\circ$) is used for clamping which need rotation movements of the workholding fixture on the machine table, it allows to get quickly and with centesimal precision any angle.

16 Art. 120

Le ganasce fisse monoblocco consentono, una volta ruotate di 180° , il perfetto accoppiamento al gradino della ganascia prismatica mobile (Art. 217) ordinabile separatamente.

The solid standard fixed jaws with 5x5 mm back steps are matchable, if turned of 180° , to the prismatic movable jaw (Art.217) to be ordered separately.

17 Art. 127

Ganascia mobili guidate monoblocco costruite con un angolo di spinta verso il basso.
 Guided movable jaws built in one solid body with a pull down angle

18 Art. 1 + Art.105

Morsa con base girevole
 Vise with swivel base

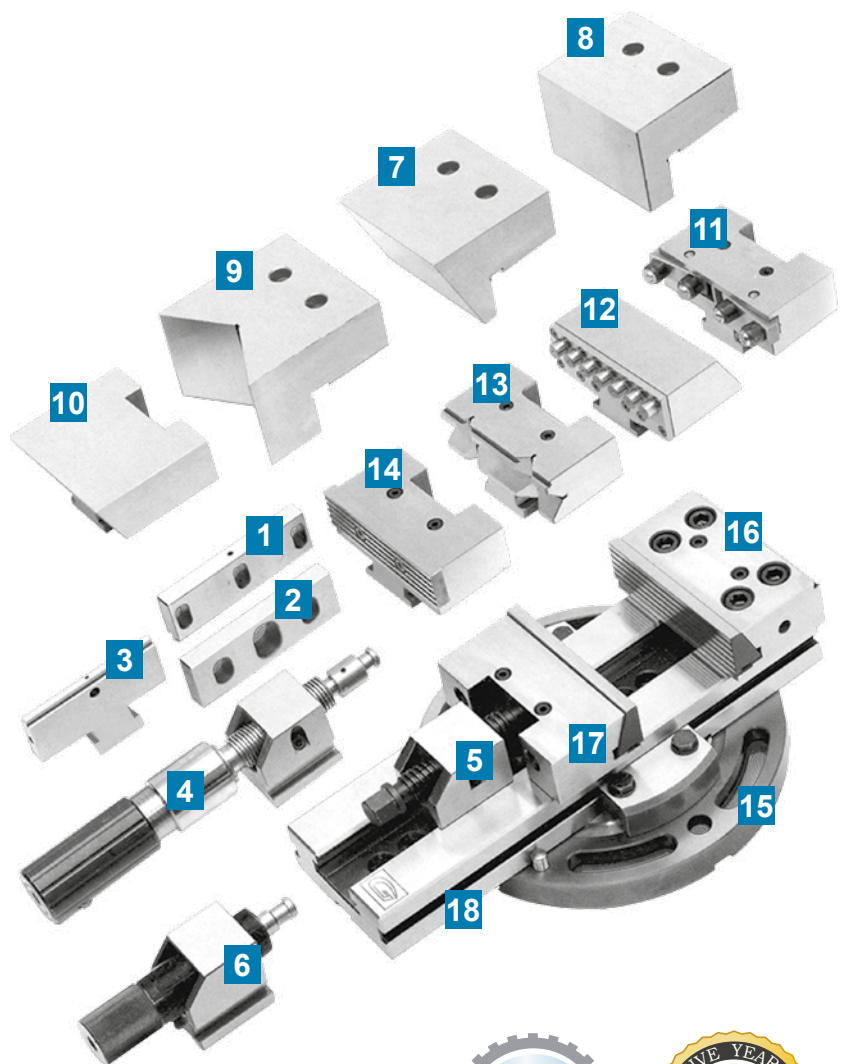

ESEMPI APPLICATIVI APPLICATION EXAMPLES

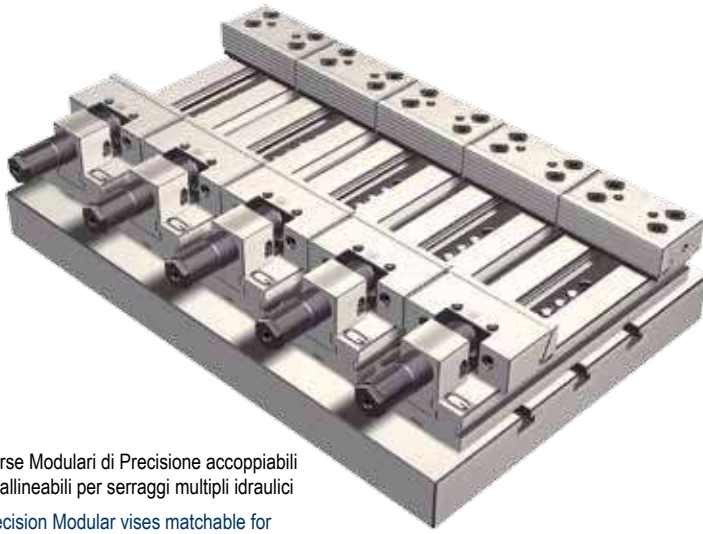

Morse Modulari di Precisione accoppiabili ed allineabili per serraggi multipli idraulici con ganasce speciali
Precision Modular vises matchable for gang operations and hydraulic clamping with special jaws

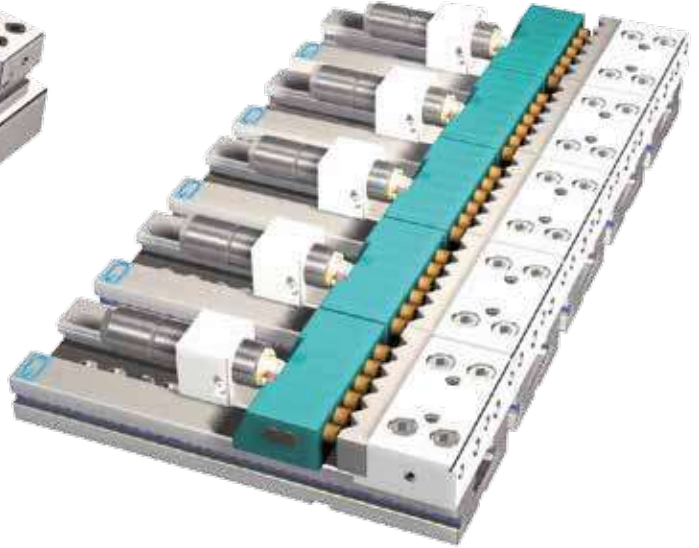

Morse Modulari di Precisione accoppiabili ed allineabili per serraggi multipli idraulici
Precision Modular vises matchable for gang operations and hydraulic clamping

NEW!

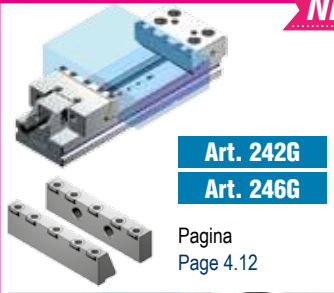

Art. 242G
Art. 246G
Pagina
Page 4.12

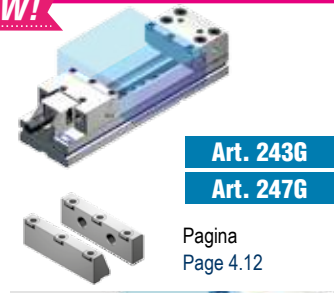

Art. 243G
Art. 247G
Pagina
Page 4.12



Art. 210
Pagina
Page 4.20



Art. 188
Pagina
Page 4.21

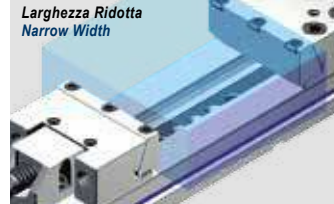
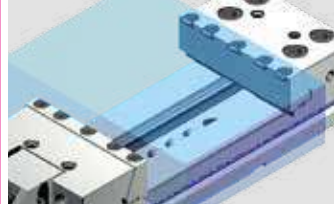

NEW INSERT GRIP JAW PLATES



Art. 160
Pagina
Page 4.14



Art. 200
Pagina
Page 4.15



Art. 212
Pagina
Page 4.19



Art. 217
Pagina
Page 4.20

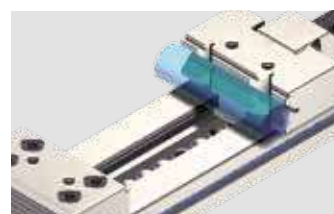
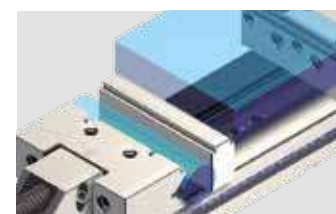
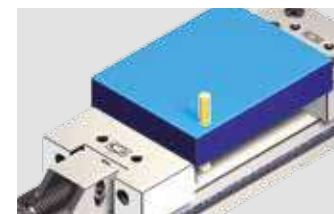
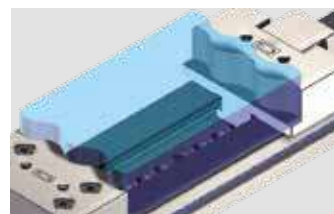

ESEMPI APPLICATIVI APPLICATION EXAMPLES

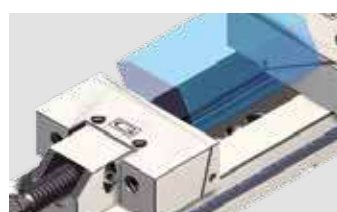
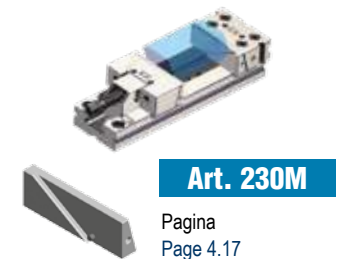
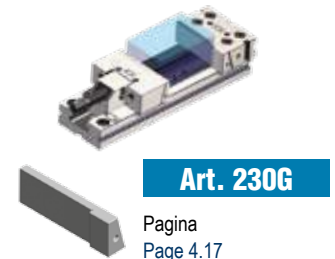
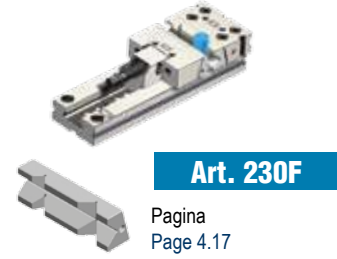
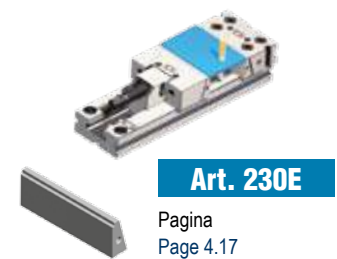
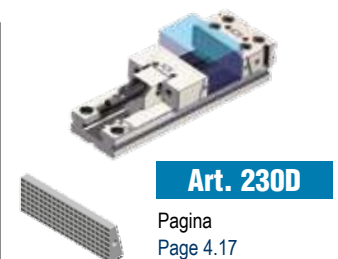
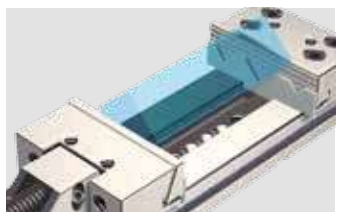
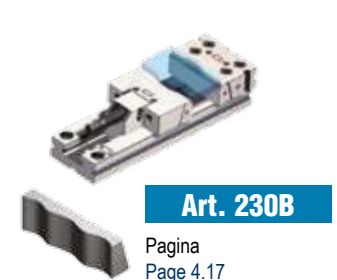

Ganasce STANDARD / STANDARD jaws

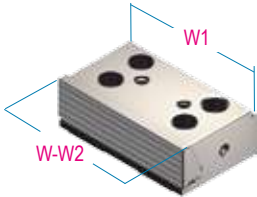
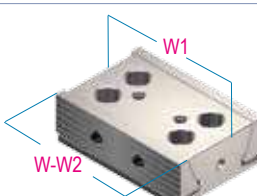
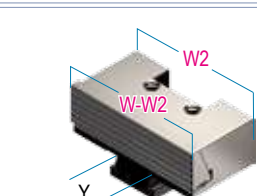
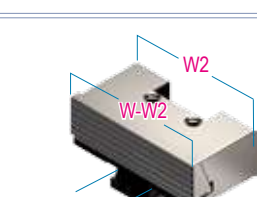
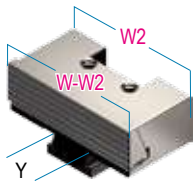
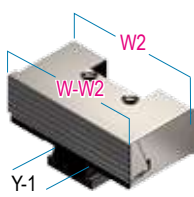
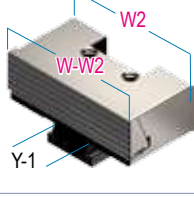
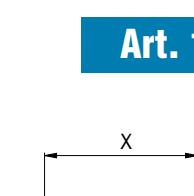
Tipo (grandezza) morsa / Vise (type) size	1	2	3	4	5	6
Art. 120 W Ganasce fissa. Larghezza normale (W) Fixed jaw. Normal width (W)						
Cod.						
Art. 121 W2 Ganasce fissa. Larghezza ridotta rettificata (W2) Fixed jaw. Narrow width ground (W2)						
Cod.						
Art. 123 W Ganasce fissa doppia. Larghezza normale (W) Double fixed jaw. Normal width (W)						
Cod.						
Art. 124 W2 Ganasce fissa doppia. Larghezza ridotta rettificata (W2) Double fixed jaw. Narrow width ground (W2)						
Cod.						
Art. 127 W Ganasce mobile monoblocco guidata. Larghezza normale (W) Guided movable solid jaw. Normal width (W)						
Cod.						
Art. 129 W2 Ganasce mobile monoblocco guidata. Larghezza ridotta (W2) Guided movable solid jaw. Narrow width (W2)						
Cod.						
Art. 126 W Ganasce mobile oscillante . Larghezza normale (W) Floating movable jaw. Normal width (W)						
Cod.						
Art. 128 W2 Ganasce mobile oscillante . Larghezza ridotta (W2) Floating movable jaw. Narrow width (W2)						
Cod.						

Art. 120

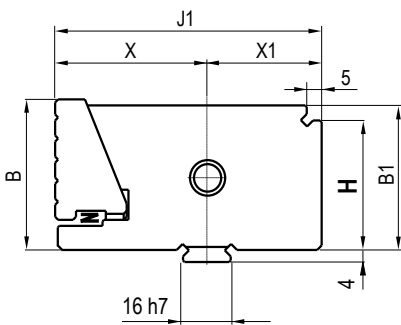

Art. 123

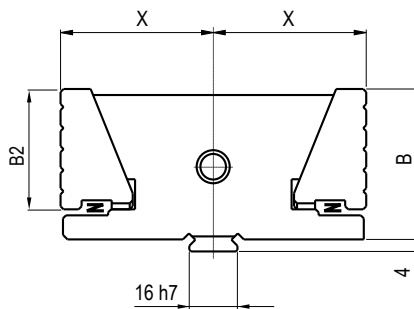

Art. 127

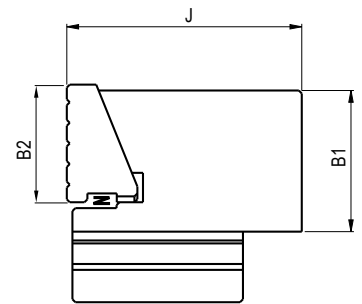

W1 = W2 + 1mm

Tipo / Type	1	2	3	4	5	6
W	100	125	150	175	200	300
W2	74	94	124	144	169	194
Y	21	28	41	51	61	71
Y - 1	20	27	40	50	60	70
B	30	40	50	60	65	80
B1	28	38	48	58	63	78
B2	24,5	32	39	43	53	63
* H	23	33	43	53	53	68
J	50	60	80	90	100	120
X	42,4	42,4	50,9	55,4	66,4	73,1
X1	35,5	35,5	38,5	41,5	47	47
J1	77,9	77,9	89,4	96,9	113,4	120,1

* DIMENSIONE DA ACCOPPIARE AD Art. 212 + 217 + 214 - DIMENSION TO BE MATCHED WITH Art. 212 + 217 + 214

Ricambi per ganasce STANDARD / Spares for STANDARD jaws

Tipo (grandezza) morsa / Vise (type) size

1 2 3 4 5 6

PIASTRE TEMPRATE RIGATE O QUADRETTATE

HARDENED GROOVED OR SERRATED JAW PLATES

Standard

A richiesta / On request

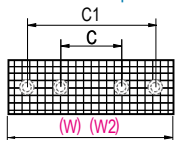
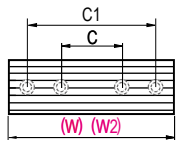

Art. 230 (W)

Art. 230S (W)

Per ganaschia fissa e mobile - Art. 120, 126, 127 - Larghezza normale (W)
For fixed and movable jaw - Art. 120, 126, 127 - Normal width (W)

Art. 231

Art. 231S

Per ganaschia fissa e mobile - Art. 121, 128, 129 - Larghezza ridotta (W2)
For fixed and movable jaw - Art. 121, 128, 129 - Narrow width (W2)

Standard

A richiesta / On request

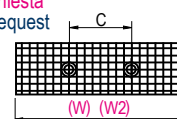
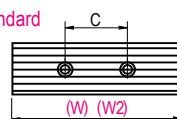

Art. 248 (W)

Art. 248S (W)

Per ganaschia fissa doppia Art. 123 - Larghezza normale (W)
For double fixed jaw Art. 123 - Normal width (W)

Art. 249 (W2)

Art. 249S (W2)

Per ganaschia fissa doppia Art. 124 - Larghezza ridotta (W2)
For double fixed jaw Art. 124 - Narrow width (W2)

Per qualsiasi piastra ganaschia speciale, raddoppiare il prezzo / For special tailor made jaw plate double the price

W	100	125	150	175	200	300
W2	74	94	124	144	169	194
A	14	20	24	24	29	35
B2	24,5	32	39	43	53	63
C	20	32	50	50	76	90
C1	62	80	90	116	138	184

Cod. Art. 230	1.65.10000	1.65.20000	1.65.30000	1.65.40000	1.65.50000	1.65.60000
Cod. Art. 230S	4.23.0S100	4.23.0S200	4.23.0S300	4.23.0S400	4.23.0S500	4.23.0S600

Cod. Art. 231	1.65.11000	1.65.21000	1.65.31000	1.65.41000	1.65.51000	1.65.61000
Cod. Art. 231S	4.23.1S100	4.23.1S200	4.23.1S300	4.23.1S400	4.23.1S500	4.23.1S600

ATTENZIONE - ATTENTION:

IN FASE D'ORDINE VERIFICARE QUOTE C - C1 - CHECK DIMENSIONS C - C1 IN CASE OF ORDER

Cod. Art. 248	1.65.14000	1.65.24000	1.65.34000	1.65.44000	1.65.54000	1.65.64000
Cod. Art. 248S	4.24.8S100	4.24.8S200	4.24.8S300	4.24.8S400	4.24.8S500	4.24.8S600

Cod. Art. 249	1.65.15000	1.65.25000	1.65.35000	1.65.45000	1.65.55000	1.65.65000
Cod. Art. 249S	4.24.9S100	4.24.9S200	4.24.9S300	4.24.9S400	4.24.9S500	4.24.9S600

PIASTRE LISCE TEMPRATE

Fornibili a richiesta su ganasce e morse senza variazione di prezzo

HARDENED SMOOTH JAW PLATES

Available on request for complete jaws and vises without price change

Art. 232 (W)

Per ganaschia fissa e mobile - Art. 120, 127, 129 - Larghezza normale (W)
For fixed and movable jaw - Art. 120, 127, 129 - Normal width (W)

Art. 233 (W2)

Per ganaschia fissa e mobile - Art. 121, 128, 129 - Larghezza ridotta (W2)
For fixed and movable jaw - Art. 121, 128, 129 - Narrow width (W2)

Art. 250 (W)

Per ganaschia fissa doppia Art. 123 - Larghezza normale (W)
For double fixed jaw Art. 123 - Normal width (W)

Art. 251 (W2)

Per ganaschia fissa doppia Art. 124 - Larghezza ridotta (W2)
For double fixed jaw Art. 124 - Narrow width (W2)

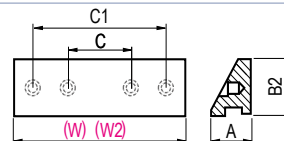

Cod. Art. 232	1.65.10100	1.65.20100	1.65.30100	1.65.40100	1.65.50100	1.65.60100
---------------	------------	------------	------------	------------	------------	------------

Cod. Art. 233	1.65.11100	1.65.21100	1.65.31100	1.65.41100	1.65.51100	1.65.61100
---------------	------------	------------	------------	------------	------------	------------

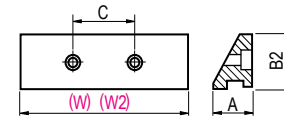

Cod. Art. 250	1.65.14100	1.65.24100	1.65.34100	1.65.44100	1.65.54100	1.65.64100
---------------	------------	------------	------------	------------	------------	------------

Cod. Art. 251	1.65.15100	1.65.25100	1.65.35100	1.65.45100	1.65.55100	1.65.65100
---------------	------------	------------	------------	------------	------------	------------

PIASTRE IN ACCIAIO LAVORABILE (DOLCE)

Fornibili a richiesta su ganasce e morse senza variazione di prezzo

MACHINEABLE STEEL JAW PLATES (SOFT)

Available on request for complete jaws and vises without price change

Art. 234 (W)

Per ganaschia fissa e mobile - Art. 120, 127, 129 - Larghezza normale (W)
For fixed and movable jaw - Art. 120, 127, 129 - Normal width (W)

Art. 235 (W2)

Per ganaschia fissa e mobile - Art. 121, 128, 129 - Larghezza ridotta (W2)
For fixed and movable jaw - Art. 121, 128, 129 - Narrow width (W2)

Art. 252 (W)

Per ganaschia fissa doppia Art. 123 - Larghezza normale (W)
For double fixed jaw Art. 123 - Normal width (W)

Art. 253 (W2)

Per ganaschia fissa doppia Art. 124 - Larghezza ridotta (W2)
For double fixed jaw Art. 124 - Super narrow width (W2)

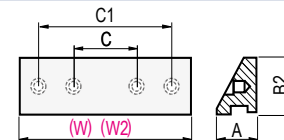

Cod. Art. 234	1.65.10200	1.65.20200	1.65.30200	1.65.40200	1.65.50200	1.65.60200
---------------	------------	------------	------------	------------	------------	------------

Cod. Art. 235	1.65.11200	1.65.21200	1.65.31200	1.65.41200	1.65.51200	1.65.61200
---------------	------------	------------	------------	------------	------------	------------

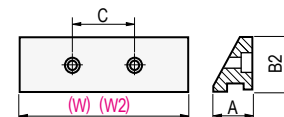

Cod. Art. 252	1.65.14200	1.65.24200	1.65.34200	1.65.44200	1.65.54200	1.65.64200
---------------	------------	------------	------------	------------	------------	------------

Cod. Art. 253	1.65.15200	1.65.25200	1.65.35200	1.65.45200	1.65.55200	1.65.65200
---------------	------------	------------	------------	------------	------------	------------

Ganasce con PIASTRE PIANE / STRAIGHT PLATE jaws

Tipo (grandezza) morsa / Vise (type) size		1	2	3	4	5	6			
Art. 140 W	Ganasce fissa. Larghezza normale (W) Fixed jaw. Normal width (W)			Cod.	2.14.01000	2.14.02000	2.14.03000	2.14.04000	2.14.05000	2.14.06000
Art. 141 W2	Ganasce fissa. Larghezza ridotta rettificata (W2) Fixed jaw. Narrow width ground (W2)			Cod.	2.14.11000	2.14.12000	2.14.13000	2.14.14000	2.14.15000	2.14.16000
Art. 143 W	Ganasce fissa doppia. Larghezza normale (W) Double fixed jaw. Normal width (W)			Cod.	2.14.31000	2.14.32000	2.14.33000	2.14.34000	2.14.35000	2.14.36000
Art. 144 W2	Ganasce fissa doppia. Larghezza ridotta rettificata (W2) Double fixed jaw. Narrow width ground (W2)			Cod.	2.14.41000	2.14.42000	2.14.43000	2.14.44000	2.14.45000	2.14.46000
Art. 146 W	Ganasce mobile monoblocco guidata. Larghezza normale (W) Guided movable solid jaw. Normal width (W)			Cod.	2.14.61000	2.14.62000	2.14.63000	2.14.64000	2.14.65000	2.14.66000
Art. 147 W2	Ganasce mobile monoblocco guidata. Larghezza ridotta (W2) Guided movable solid jaw. Narrow width (W2)			Cod.	2.14.71000	2.14.72000	2.14.73000	2.14.74000	2.14.75000	2.14.76000
Art. 148 W	Ganasce mobile monoblocco oscillante. Larghezza normale (W) Floating movable solid jaw. Normal width (W)			Cod.	2.14.81000	2.14.82000	2.14.83000	2.14.84000	2.14.85000	2.14.86000
Art. 149 W2	Ganasce mobile monoblocco oscillante. Larghezza ridotta (W2) Floating movable solid jaw. Narrow width (W2)			Cod.	2.14.91000	2.14.92000	2.14.93000	2.14.94000	2.14.95000	2.14.96000

Art. 140

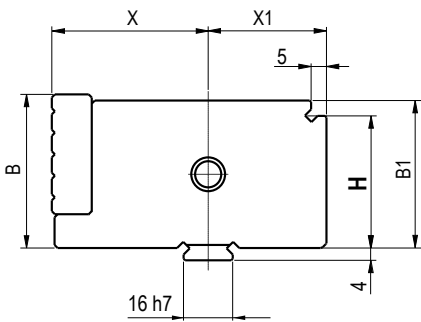

Art. 143

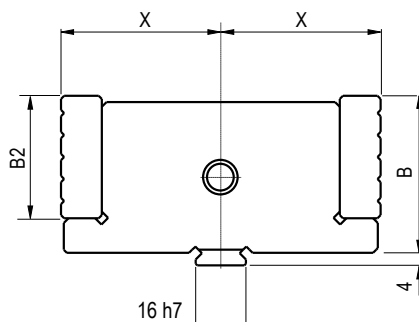

Art. 146

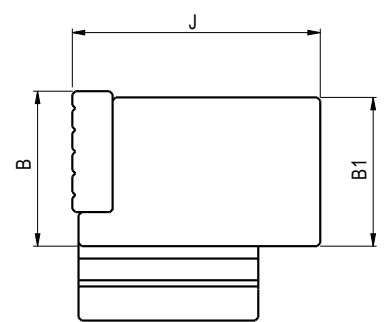

W1 = W2 + 1mm

Tipo / Type	1	2	3	4	5	6
W	100	125	150	175	200	300
W2	74	94	124	144	169	194
Y	21	28	41	51	61	71
Y-1	20	27	40	50	60	70
B	30	40	50	60	65	80
B1	28	38	48	58	63	78
B2	24,5	32	40	43	48	63
* H	23	33	43	53	53	68
J	50	60	80	90	100	120
X	42,4	42,4	50,9	55,4	66,4	73,1
X1	35,5	35,5	38,5	41,5	47	47

* DIMENSIONE DA ACCOPPIARE AD Art. 212 + 217 + 214 - DIMENSION TO BE MATCHED WITH Art. 212 + 217 + 214

Ricambi per ganasce con PIASTRE PIANE / Spares for STRAIGHT STD jaws

Tipo (grandezza) morsa / Vise (type) size

1 2 3 4 5 6

PIASTRE PIANE TEMPRATE, RIGATE O QUADRETTATE

HARDENED GROOVED OR SERRATED STRAIGHT JAW PLATES

Dotazione normale delle ganasce e delle morse complete
Standard equipment on complete jaws and vises

Per qualsiasi piastra ganascia speciale, raddoppiare il prezzo / For special tailor made jaw plate double the price

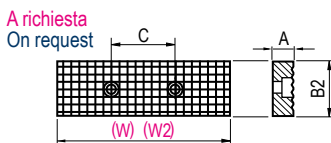
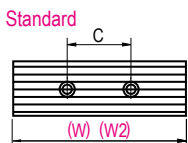

Art. 242

(W)

Art. 242S

(W)

Per ganascia fissa e mobile - Art. 140, 143, 146 - Larghezza normale (W)
For fixed and movable jaw - Art. 140, 143, 146 - Normal width (W)

W	100	125	150	175	200	300
W2	74	94	124	144	169	194
A	12	12	13	13	18	18
B2	24,5	32	40	43	48	56
C	25	32	50	50	76	90

Cod. Art. 242	1.65.16000	1.65.26000	1.65.36000	1.65.46000	1.65.56000	1.65.66000
Cod. Art. 242S	4.24.2S100	4.24.2S200	4.24.2S300	4.24.2S400	4.24.2S500	4.24.2S600

Art. 243

(W2)

Art. 243S

(W2)

Per ganascia fissa e mobile - Art. 141, 144, 147 - Larghezza ridotta (W2)
For fixed and movable jaw - Art. 141, 144, 147 - Narrow width (W2)

Cod. Art. 243	1.65.17000	1.65.27000	1.65.37000	1.65.47000	1.65.57000	1.65.67000
Cod. Art. 243S	4.24.3S100	4.24.3S200	4.24.3S300	4.24.3S400	4.24.3S500	4.24.3S600

PIASTRE PIANE LISCE TEMPRATE

Fornibili a richiesta su ganasce e morse senza variazione di prezzo

HARDENED SMOOTH STRAIGHT JAW PLATES

Available on request for complete jaws and vises without price change

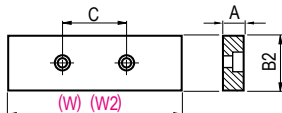

Art. 244

(W)

Per ganascia fissa e mobile - Art. 140, 143, 146 - Larghezza normale (W)
For fixed and movable jaw - Art. 140, 143, 146 - Normal width (W)

Cod. Art. 244	4.24.41000	4.24.42000	4.24.43000	4.24.44000	4.24.45000	4.24.46000
---------------	------------	------------	------------	------------	------------	------------

Art. 245

(W2)

Per ganascia fissa e mobile - Art. 141, 144, 147 - Larghezza ridotta (W2)
For fixed and movable jaw - Art. 141, 144, 147 - Narrow width (W2)

Cod. Art. 245	4.24.51000	4.24.52000	4.24.53000	4.24.54000	4.24.55000	4.24.56000
---------------	------------	------------	------------	------------	------------	------------

PIASTRE PIANE IN ACCIAIO LAVORABILE (DOLCE)

Fornibili a richiesta su ganasce e morse senza variazione di prezzo

MACHINEABLE STEEL STRAIGHT JAW PLATES (SOFT HRC)

Available on request for complete jaws and vises without price change

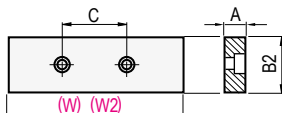

Art. 246

(W)

Per ganascia fissa e mobile - Art. 140, 143, 146 - Larghezza normale (W)
For fixed and movable jaw - Art. 140, 143, 146 - Normal width (W)

Cod. Art. 246	1.65.16200	1.65.26200	1.65.36200	1.65.46200	1.65.56200	1.65.66200
---------------	------------	------------	------------	------------	------------	------------

Art. 247

(W2)

Per ganascia fissa e mobile - Art. 141, 144, 147 - Larghezza ridotta (W2)
For fixed and movable jaw - Art. 141, 144, 147 - Narrow width (W2)

Cod. Art. 247	1.65.17200	1.65.27200	1.65.37200	1.65.47200	1.65.57200	1.65.67200
---------------	------------	------------	------------	------------	------------	------------

PIASTRE PIANE TEMPRATE GRIP

Fornibili a richiesta su ganasce e morse senza variazione di prezzo

HARDENED STRAIGHT JAW PLATES GRIP

Available on request for complete jaws and vises without price change



PIASTRE GANASCE "GRIP" JAW PLATES

Superficie
Surface

Pressione
Pressure

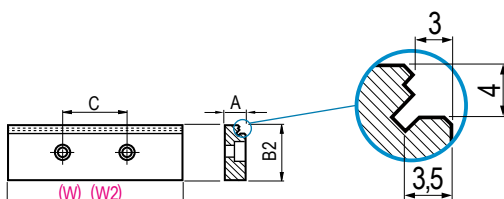

Art. 246T

(W)

Per ganascia fissa e mobile - Art. 140, 143, 146 - Larghezza normale (W)
For fixed and movable jaw - Art. 140, 143, 146 - Normal width (W)

Cod. Art. 246T	4.24.6T100	4.24.6T200	4.24.6T300	4.24.6T400	4.24.6T500	4.24.6T600
----------------	------------	------------	------------	------------	------------	------------

Art. 247T

(W2)

Per ganascia fissa e mobile - Art. 141, 144, 147 - Larghezza ridotta (W2)
For fixed and movable jaw - Art. 141, 144, 147 - Narrow width (W2)

Cod. Art. 247T	4.24.7T100	4.24.7T200	4.24.7T300	4.24.7T400	4.24.7T500	4.24.7T600
----------------	------------	------------	------------	------------	------------	------------

PIASTRE GANASCE CON INSERTI GRIP INSERT GRIP JAW PLATES

NEW!

Tipo (grandezza) morsa / Vise (type) size	1	2	3	4	5	6
---	---	---	---	---	---	---

Art. 242G **W**

Piastra Ganascia con Inserti GRIP. Larghezza normale (W)
Jaw plate with GRIP insert. Normal width (W)

Cod.	1.24.2G100	1.24.2G200	1.24.2G300	1.24.2G400	1.24.2G500	1.24.2G600

ATTENZIONE - ATTENTION:
Utilizzare solo con viti posteriori ben serrate - Using only with rear screws strong clamped

Art. 243G **W2**

Piastra Ganascia con Inserti GRIP. Larghezza ridotta rettificata (W1)
Jaw plate with GRIP insert. Narrow width ground (W1)

Cod.	1.24.3G100	1.24.3G200	1.24.3G300	1.24.3G400	1.24.3G500	1.24.3G600

Art. 246G **W**

Piastra Piana con Inserti GRIP. Larghezza normale (W)
Straight Plate with GRIP inserts. Normal width (W)

Cod.	1.24.6G100	1.24.6G200	1.24.6G300	1.24.6G400	1.24.6G500	1.24.6G600

Art. 247G **W2**

Piastra Piana con Inserti GRIP. Larghezza ridotta rettificata (W1)
Straight Plate with GRIP inserts. Narrow width ground (W1)

Cod.	1.24.7G100	1.24.7G200	1.24.7G300	1.24.7G400	1.24.7G500	1.24.7G600

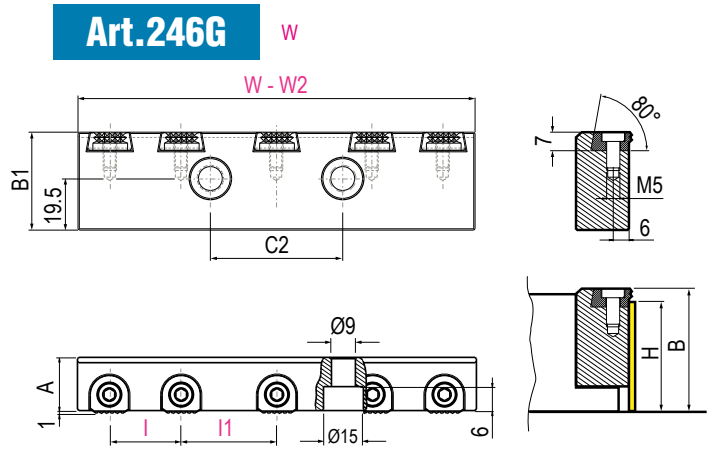
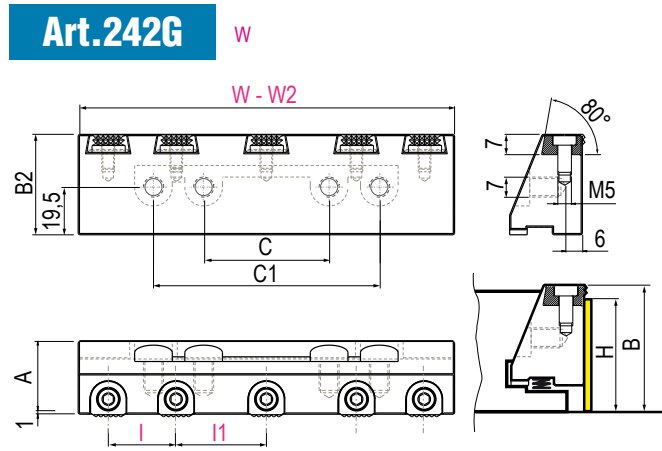

Dotazione Standard - Standard Equipment
1 pc. Art.313 parallela magnetica - 1 pc. Art.313 magnetic parallel

Tipo / Type	1	2	3	4	5	6
W	100	125	150	175	200	300
W2	74	94	124	144	169	194
I	35	43	36-27	35	27	33
I1	25	32	47	28,5	35	27
C	20	32	50	50	76	90
C1	62	80	90	116	138	184
C2	25	32	50	50	76	80
B	30	40	50	60	65	80
B1	24,5	32	40	43	48	56
B2	24,5	32	40	40	53	53
A	14	20	24	24	29	35
A1	12	12	13	13	18	18
H	25	35	45	55	60	75

4

PIASTRE GANASCE CON INSERTI GRIP INSERT GRIP JAW PLATES

NEW!

Art.242G

Piastra Ganaschia con Inserti GRIP
Jaw plate with GRIP inserts

Art.246G

Piastra Piana con Inserti GRIP
Straight Plate with GRIP inserts

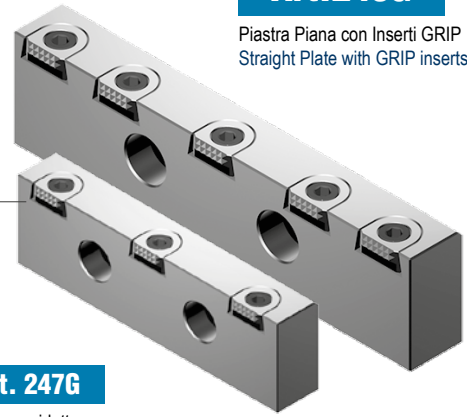
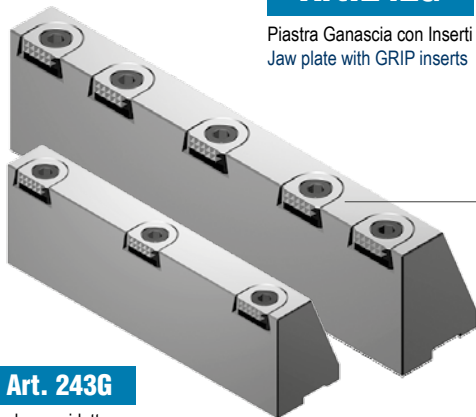

Art. 243G

Larghezza ridotta
Narrow width

Art. 247G

Larghezza ridotta
Narrow width

Inserti Grip - Grip Inserts

Art. 220 G01

Per materiali di durezza normale
For standard workpieces hardness clamping

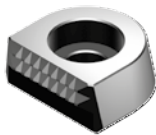

Art. 220 G02

Per materiali di notevole durezza.
For hardened workpieces clamping

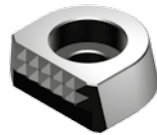

Art. 220 G11

Per materiali teneri
For soft material clamping



Cod. 4.22.01000 / G01

Cod. 4.22.01000 / G02

Cod. 4.22.01000 / G11

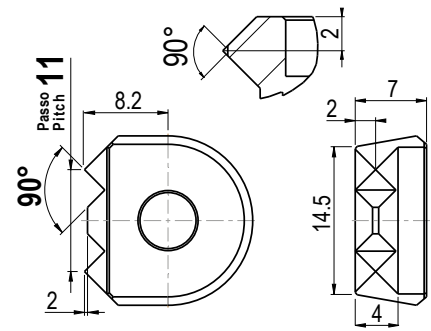
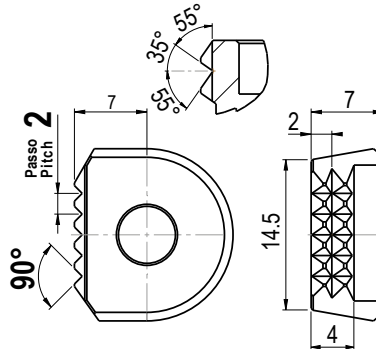
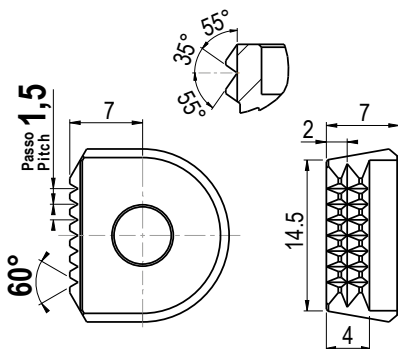

Tipo / Type	1	2	3	4	5	6
Art.242G - Art.246G	3 pcs each jaw plate	3 pcs each jaw plate	5 pcs each jaw plate	5 pcs each jaw plate	7 pcs each jaw plate	9 pcs each jaw plate
Art.243G - Art.247G	3 pcs each jaw plate	3 pcs each jaw plate	3 pcs each jaw plate	5 pcs each jaw plate	5 pcs each jaw plate	7 pcs each jaw plate



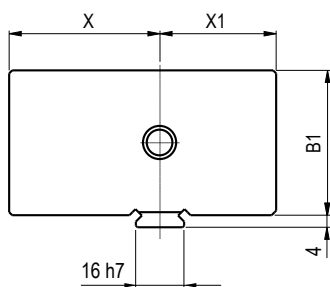
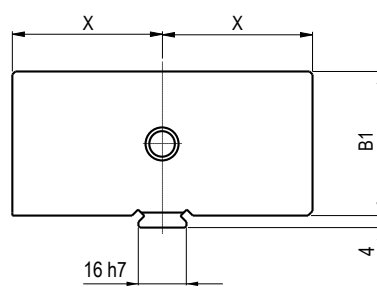
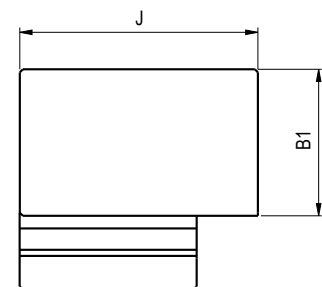

Ganasce lavorabili (dolci) MONOBLOCCO / SOLID machineable (soft) jaws

Tipo (grandezza) morsa / Vise (type) size		1	2	3	4	5	6	
Art. 160 W3 Ganascia fissa. Larghezza normale (W3) Fixed jaw. Normal width (W3)		Cod.	2.16.01000	2.16.02000	2.16.03000	2.16.04000	2.16.05000	2.16.06000
Art. 161 W1 Ganascia fissa. Larghezza ridotta rettificata (W1) Fixed jaw. Narrow width grinded (W1)		Cod.	2.16.11000	2.16.12000	2.16.13000	2.16.14000	2.16.15000	2.16.16000
Art. 163 W3 Ganascia fissa doppia. Larghezza normale (W3) Double fixed jaw. Normal width (W3)		Cod.	2.16.31000	2.16.32000	2.16.33000	2.16.34000	2.16.35000	2.16.36000
Art. 164 W1 Ganascia fissa doppia. Larghezza ridotta rettificata (W1) Double fixed jaw. Narrow width grinded (W1)		Cod.	2.16.41000	2.16.42000	2.16.43000	2.16.44000	2.16.45000	2.16.46000
Art. 166 W3 Ganascia mobile monoblocco guidata. Larghezza normale (W3) Guided movable solid jaw. Normal width (W3)		Cod.	2.16.61000	2.16.62000	2.16.63000	2.16.64000	2.16.65000	2.16.66000
Art. 167 W2 Ganascia mobile monoblocco guidata. Larghezza ridotta (W2) Guided movable solid jaw. Narrow width (W2)		Cod.	2.16.71000	2.16.72000	2.16.73000	2.16.74000	2.16.75000	2.16.76000
Art. 168 W3 Ganascia mobile monoblocco oscillante. Larghezza normale (W3) Floating movable solid jaw. Normal width (W3)		Cod.	2.16.81000	2.16.82000	2.16.83000	2.16.84000	2.16.85000	2.16.86000
Art. 169 W2 Ganascia mobile monoblocco oscillante. Larghezza ridotta (W2) Floating movable solid jaw. Narrow width (W2)		Cod.	2.16.91000	2.16.92000	2.16.93000	2.16.94000	2.16.95000	2.16.96000

HB= 290
Art. 160

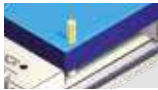
Art. 163

Art. 166

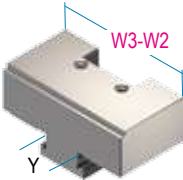
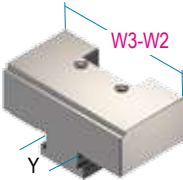
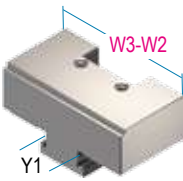
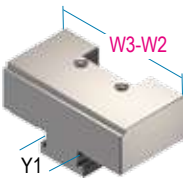
Art.	1	2	3	4	5	6
W3	96	121	146	171	196	296
W1	75	95	125	145	170	195
W2	74	94	124	144	169	194
B1	28	38	48	58	63	78
Y	21	28	41	51	61	71
Y-1	20	27	40	50	60	70
J	50	60	80	90	100	120
X	42,4	42,4	50,9	55,4	66,4	73,1
X1	35,5	35,5	36,5	41,5	47	47

Ganasce monoblocco con GRADINO. Temprate / Solid jaws with STEP. Case hardened

Tipo (grandezza) morsa / Vise (type) size	1	2	3	4	5	6
Art. 200 W3 Ganasce fissa. Larghezza normale (W3) Fixed jaw. Normal width (W3)  	Cod. 2.20.01000	2.20.02000	2.20.03000	2.20.04000	2.20.05000	2.20.06000
Art. 201 W1 Ganasce fissa. Larghezza ridotta rettificata (W1) Fixed jaw. Narrow width ground (W1) 	Cod. 2.20.11000	2.20.12000	2.20.13000	2.20.14000	2.20.15000	2.20.16000
Art. 203 W3 Ganasce fissa doppia. Larghezza normale (W3) Double fixed jaw. Normal width (W3) 	Cod. 2.20.31000	2.20.32000	2.20.33000	2.20.34000	2.20.35000	2.20.36000
Art. 204 W1 Ganasce fissa doppia. Larghezza ridotta rettificata (W1) Double fixed jaw. Narrow width ground (W1) 	Cod. 2.20.41000	2.20.42000	2.20.43000	2.20.44000	2.20.45000	2.20.46000
Art. 208 W3 Ganasce mobile monoblocco guidata. Larghezza normale (W3) Guided movable solid jaw. Normal width (W3) 	Cod. 2.20.81000	2.20.82000	2.20.83000	2.20.84000	2.20.85000	2.20.86000
Art. 209 W2 Ganasce mobile monoblocco guidata. Larghezza ridotta (W2) Guided movable solid jaw. Narrow width (W2) 	Cod. 2.20.91000	2.20.92000	2.20.93000	2.20.94000	2.20.95000	2.20.96000
Art. 206 W3 Ganasce mobile monoblocco oscillante. Larghezza normale (W3) Floating movable solid jaw. Normal width (W3) 	Cod. 2.20.61000	2.20.62000	2.20.63000	2.20.64000	2.20.65000	2.20.66000
Art. 207 W2 Ganasce mobile monoblocco oscillante. Larghezza ridotta (W2) Floating movable solid jaw. Narrow width (W2) 	Cod. 2.20.71000	2.20.72000	2.20.73000	2.20.74000	2.20.75000	2.20.76000

HRC= 60

Art. 200

Art. 203

Art. 208

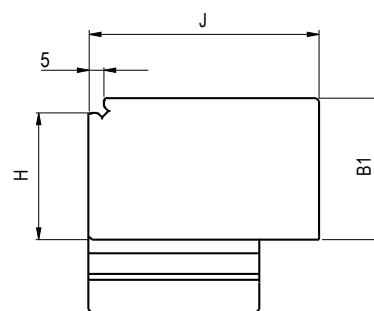
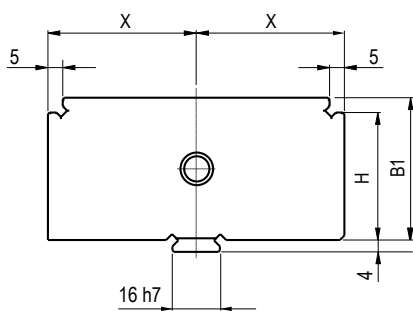
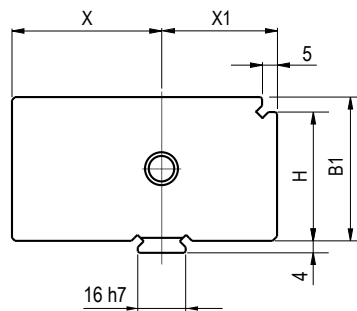

Art.	1	2	3	4	5	6
W3	96	121	146	171	196	296
W1	75	95	125	145	170	195
W2	74	94	124	144	169	194
Y	21	28	41	51	61	71
Y-1	20	27	40	50	60	70
B1	28	38	48	58	63	78
* H	23	33	43	53	53	68
J	50	60	80	90	100	120
X	42,4	42,4	50,9	55,4	66,4	73,1
X1	35,5	35,5	38,5	41,5	47	47

* DIMENSIONE DA ACCOPPIARE AD Art. 2012 + 217 + 214 - DIMENSION TO BE MATCHED WITH Art. 212 + 217 + 214

Piastra ganascia StdFLEX a cambio rapido / StdFLEX quick change jaw plates

Tipo (grandezza) morsa / Vise (type) size

1 **2** **3** **4** **5** **6**
Art. 120A

 Ganascia fissa
 Fixed jaw

Cod. 4.12.0A100 4.12.0A200 4.12.0A300 4.12.0A400 4.12.0A500 4.12.0A600

Art. 123A

 Ganascia fissa doppia
 Double fixed jaw

Cod. 4.12.3A100 4.12.3A200 4.12.3A300 4.12.3A400 4.12.3A500 4.12.3A600

Art. 126A

 Ganascia mobile oscillante
 Floating movable jaw



Cod. 4.12.6A100 4.12.6A200 4.12.6A300 4.12.6A400 4.12.6A500 4.12.6A600

Art. 127A

 Ganascia mobile guidata
 Guided movable jaw

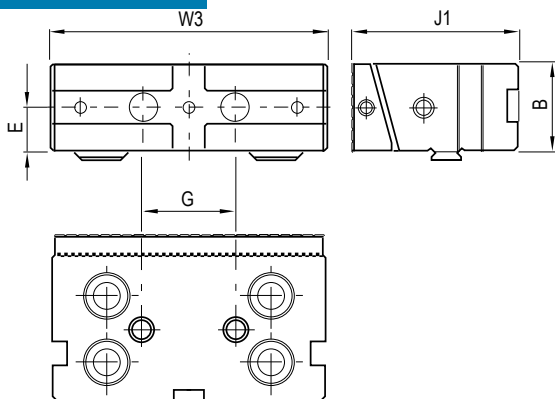
Cod. 4.12.7A100 4.12.7A200 4.12.7A300 4.12.7A400 4.12.7A500 4.12.7A600

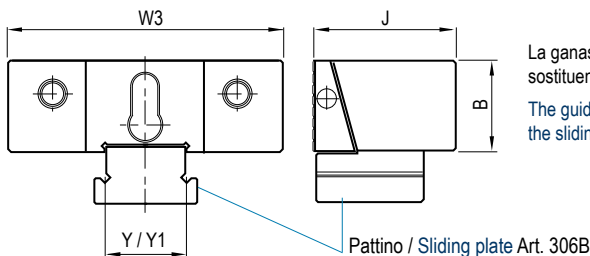
Art. 120A

HRC= 60
Ganacce StandardFLEX con piastre intercambiabili manualmente (Sistema a pettine)
StandardFLEX jaws with interchangeable jaw plates by hand (Comb system)

Art. 127A

La ganascia mobile guidata, Art. 127A, può essere tramutata in ganascia mobile oscillante, sostituendo il pattino, Art. 306B, con il pattino Art. 306C (vedi pag. 4-26)

The guided movable jaw, Art. 127A, could be transformed in a floating movable jaw by simply exchanging the sliding plate, Art. 306B, with sliding plate Art. 306C (see page 4-26)

mm	1	2	3	4	5	6
W3	96	121	146	171	196	296
W1	95	120	145	170	195	295
B	28	38	48	58	63	78
E	14	19	25	27	30	47
G	-	-	50	50	50	50
J	50	60	80	90	100	120
J1	77,9	77,9	89,4	96,9	113,4	120,4
Y	21	28	41	51	61	71
Y1	20	27	40	50	60	70

Piastrine ganascia StdFLEX a cambio rapido / StdFLEX quick change jaw plates

Tipo (grandezza) morsa / Vise (type) size

1 2 3 4 5 6

Piastrine ganasce rapide singole. Ricambi per ganasce rapide a pettine
Single quick change jaw plates. Spares for quick change comb jaw

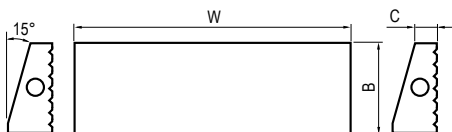

W	95	120	145	170	195	295
B	28	38	48	58	63	78
C	9	11	11	11	14	14

Art. 230B

Piastra ganascia intercambiabile dolce a pettine
Soft comb interchangeable jaw plate

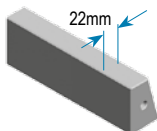

Cod.	4.23.0B101	4.23.0B201	4.23.0B301	4.23.0B401	4.23.0B501	4.23.0B601
------	------------	------------	------------	------------	------------	------------

Art. 230C

Piastra ganascia intercambiabile liscia a pettine
Smooth comb interchangeable jaw plate

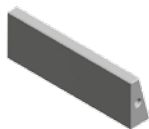

Cod.	4.23.0C101	4.23.0C201	4.23.0C301	4.23.0C401	4.23.0C501	4.23.0C601
------	------------	------------	------------	------------	------------	------------

Art. 230D

Piastra ganascia intercambiabile zigrinata a pettine
Serrated comb interchangeable jaw plate

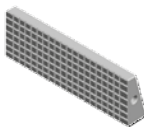

Cod.	4.23.0D101	4.23.0D201	4.23.0D301	4.23.0D401	4.23.0D501	4.23.0D601
------	------------	------------	------------	------------	------------	------------

Art. 230E

Piastra ganascia intercambiabile a gradino a pettine
Step comb interchangeable jaw plate



Vedi selezione piastrine ganascia a pag. 4.18
See jaw step selection pag. 4.18

Cod.	4.23.0E101	4.23.0E201	4.23.0E301	4.23.0E401	4.23.0E501	4.23.0E601
------	------------	------------	------------	------------	------------	------------

Art. 230F

Piastra ganascia intercambiabile prismatica a pettine
Prismatic comb interchangeable jaw plate

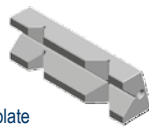

Ø min / max	A	6 / 16	9 / 24	13 / 38	15 / 40	15 / 42	15 / 42
Ø min / max	B	4 / 10	7 / 18	9 / 24	9 / 24	9 / 24	9 / 24

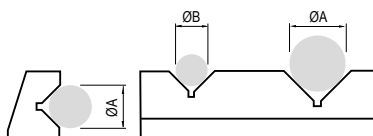

Cod.	4.23.0F101	4.23.0F201	4.23.0F301	4.23.0F401	4.23.0F501	4.23.0F601
------	------------	------------	------------	------------	------------	------------

Art. 230G

Piastra ganascia intercambiabile a pettine con arresto a 90°
90° interchangeable comb jaw plate

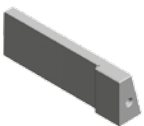

Solo 1 per morsa !! Just 1 pc each vise !!

Cod.	4.23.0G101	4.23.0G201	4.23.0G301	4.23.0G401	4.23.0G501	4.23.0G601
------	------------	------------	------------	------------	------------	------------

Art. 230H

Piastra ganascia intercambiabile bombata a pettine
Round comb interchangeable jaw plate

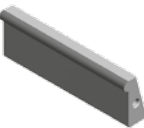

Solo 1 per morsa !! Just 1 pc each vise !!

Cod.	4.23.0H101	4.23.0H201	4.23.0H301	4.23.0H401	4.23.0H501	4.23.0H601
------	------------	------------	------------	------------	------------	------------

Art. 230M

Piastra ganascia intercambiabile a pettine per angolo di 30° o 45°
30° or 45° angle interchangeable comb jaw plate

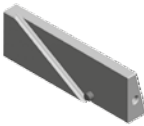

Solo 1 per morsa !! Just 1 pc each vise !!

Cod.	4.23.0M101	4.23.0M201	4.23.0M301	4.23.0M401	4.23.0M501	4.23.0M601
------	------------	------------	------------	------------	------------	------------

Ganasce StandardFLEX a cambio rapido / StandardFLEX quick change jaws

Tipo (grandezza) morsa / Vise (type) size	1	2	3	4	5	6
---	---	---	---	---	---	---

Art. 230E Set

Set di coppie di piastre ganasce a cambio rapido a gradino Art. 230E
Set of pairs of quick change step jaw plates Art 230E

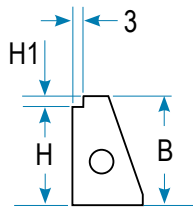
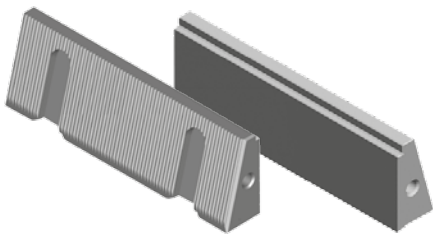

RISPARMIO DEL 40 % - SAVE 40 %

B	28	38	48	58	63	78
H1	Set di 8 pezzi / Set of 8 pcs	3	3	3	3	3
		5	5	5	5	5
		8	8	8	8	10
		13	13	13	13	13
		-	18	18	18	18
H	Set di 12 pezzi / Set of 12 pcs	-	23	23	23	23
		-	28	28	28	28
	Set di 14 pezzi / Set of 14 pcs	-	43	43	43	43
		-	53	53	53	53
	Set di 16 pezzi / Set of 16 pcs	-	68	68	68	68
Cod.	4.23.0E112	4.23.0E212	4.23.0E312	4.23.0E412	4.23.0E512	4.23.0E612

Prezzo set di coppie - Price set of pairs

Cod.	4.23.0E101	4.23.0E201	4.23.0E301	4.23.0E401	4.23.0E501	4.23.0E601
------	------------	------------	------------	------------	------------	------------

Prezzo Cad. se acquistate con set - Price each in case of purchase of a set

Art. 605G1

Vite a gradino / Step screw



Cod. 6.60.5G101

Art. 605G2

Perno a molla / Spring pin



Cod. 6.60.5G202

Art. 605G3

Molla / Spring



Cod. 6.60.5G301

Risparmio del **33%** sul raccoglitore Art.320 (vuoto) se acquistato insieme ad un set di piastre ganasce **Art.230A**
Save **33%** purchasing the rack Art.320 together with the small or big set of straight magnetic parallels plates **Art.230E**

Art. 320A

Portapiastre Art.320 completo di piastre ganasce a cambio rapido a gradino Art. 230E
Rack Art.320 complete of quick change step jaw plates Art 230E



Cod. 4.32.0A100 4.32.0A200 4.32.0A300 4.32.0A400 4.32.0A500 4.32.0A600

Art. 320

Portapiastre
Rack



Cod. 4.32.01000 4.32.02000 4.32.03000 4.32.04000 4.32.05000 4.32.06000

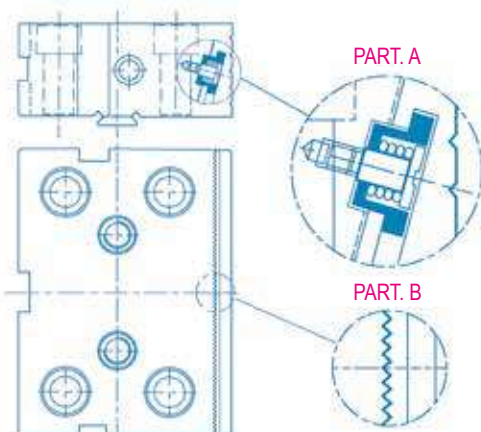

Rapida sostituzione delle piastre ganasce discendenti senza bisogno di alcun utensile

Il nuovo sistema con piastre ganasce intercambiabili, conferisce alla morsa STD un ulteriore aumento di versatilità dato dalla rapidità di sostituzione delle piastre ganasce e dalla precisione di riposizionamento.

La rapidità di sostituzione delle piastre ganasce è resa possibile dal nuovo sistema con perno a molla (PART. A), mentre le righe prismatiche (PART. B) effettuate con mola sagomata sui piani d'appoggio rendono possibile un riposizionamento di elevata precisione.

Quick hand change of downward jaw plates - no tools needed

The new system with quick interchangeable jaw plates increases the STD vise versatility, and allows the quick jaw allows plates replacement and their high precision repositioning.

The speed of the jaw replacement is allowed by the new design of pin with spring (PART. A), while the prismatic grooves (PART. B), made with shaped grind wheel on the surface plates, allow a perfect repositioning.

The wide range of interchangeable jaw plates can satisfy the most varied workholding needs.

Ganasce MOBILI INTERMEDIE / INTERMEDIATE MOVABLE jaws

Tipo (grandezza) morsa / Vise (type) size

1 2 3 4 5 6

Art. 212 W3

Ganasce mobile intermedia con doppio gradino.
Larghezza normale (W3)

Intermediate movable jaw with double step.
Normal width (W3)

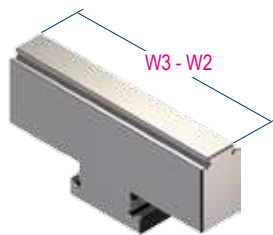

Cod. 1.21.21000 1.21.22000 1.21.23000 1.21.24000 1.21.25000 1.21.26000



Art. 213 W2

Ganasce mobile intermedia con doppio gradino.
Larghezza ridotta (W2)

Intermediate movable jaw with double step.
Narrow width (W2)

Cod. 1.21.31000 1.21.32000 1.21.33000 1.21.34000 1.21.35000 1.21.36000

Art. 214 W3

Ganasce mobile intermedia prismatica.
Larghezza normale (W3)

Prismatic intermediate movable jaw.
Normal width (W3)

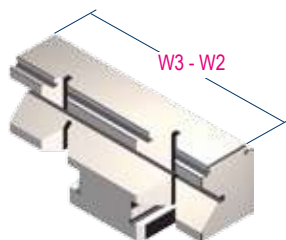

Cod. 1.21.41000 1.21.42000 1.21.43000 1.21.44000 1.21.45000 1.21.46000

Art. 215 W2

Ganasce mobile intermedia.
Larghezza ridotta (W2)

Intermediate movable jaw.
Narrow width (W2)

Cod. 1.21.51000 1.21.52000 1.21.53000 1.21.54000 1.21.55000 1.21.56000

Art. 224 W3

Ganasce mobile intermedia.
Larghezza normale (W3)

Intermediate movable jaw.
Normal width (W3)

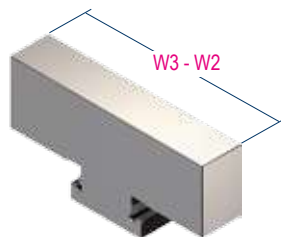

Cod. 1.22.41000 1.22.42000 1.22.43000 1.22.44000 1.22.45000 1.22.46000

Art. 225 W2

Ganasce mobile intermedia.
Larghezza ridotta (W2)

Intermediate movable jaw.
Narrow width (W2)

Cod. 1.22.51000 1.22.52000 1.22.53000 1.22.54000 1.22.55000 1.22.56000

Art. 212

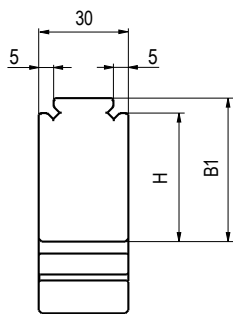

Art. 214

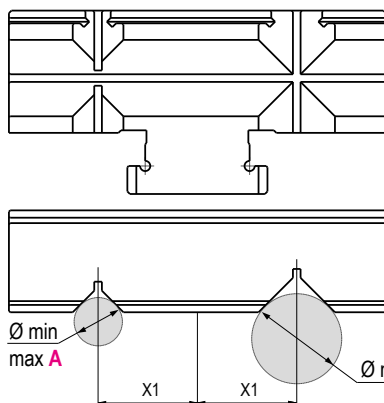

Art. 224

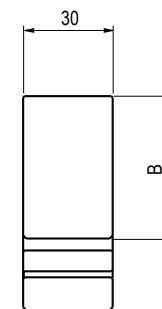
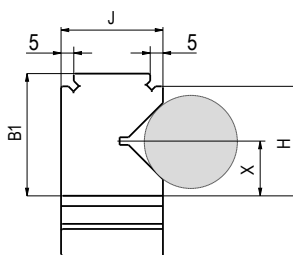

Art.	1	2	3	4	5	6
W3	96	121	146	171	196	296
W2	74	94	124	144	169	194
B	30	40	50	60	65	80
B1	28	38	48	58	63	78
H	23	33	43	53	53	68
J	30	30	40	40	45	50
X	11,5	16,5	21,5	26,5	26,5	34
X1	25	33	39	50	55	70
Ø min/max A	4 - 10	7 - 18	9 - 24	9 - 24	9 - 24	10 - 28
Ø min/max B	6 - 16	9 - 24	13 - 38	15 - 40	15 - 42	18 - 46

Ganasce MOBILI PRISMATICHE / PRISMATIC MOVABLE jaws

Tipo (grandezza) morsa / Vise (type) size	1	2	3	4	5	6
Art. 217 W3 Ganascia mobile guidata prismatica. Larghezza normale (W3) Prismatic guided movable jaw. Normal width (W3)	Cod. 2.21.71000	2.21.72000	2.21.73000	2.21.74000	2.21.75000	2.21.76000
Art. 218 W2 Ganascia mobile guidata prismatica. Larghezza ridotta (W2) Prismatic guided movable jaw. Narrow width (W2)	Cod. 2.21.81000	2.21.82000	2.21.83000	2.21.84000	2.21.85000	2.21.86000

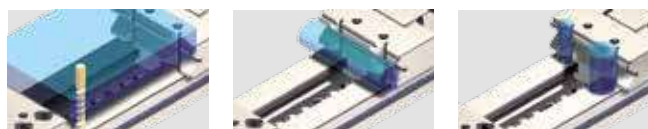
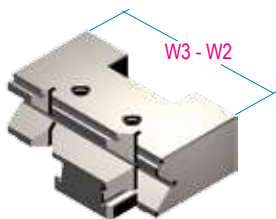

Art. 152 W2 Inserto prismatico. Larghezza ridotta (W2) Prismatic insert. Narrow width (W2)	Cod. 4.15.21000	4.15.22000	4.15.23000	4.15.24000	4.15.25000	4.15.26000
--	-----------------	------------	------------	------------	------------	------------

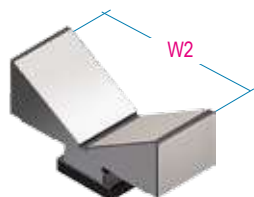

Ganasce per PARTICOLARI TONDI / Jaws for ROUND WORKPIECE

Art. 210 W3 Ganascia mobile oscillante. Larghezza normale (W3) Floating movable jaw. Normal width (W3)	Cod. 2.21.01000	2.21.02000	2.21.03000	2.21.04000	2.21.05000	2.21.06000
Art. 211 W2 Ganascia mobile oscillante. Larghezza ridotta (W2) Floating movable jaw. Narrow width (W2)	Cod. 2.21.11000	2.21.12000	2.21.13000	2.21.14000	2.21.15000	2.21.16000

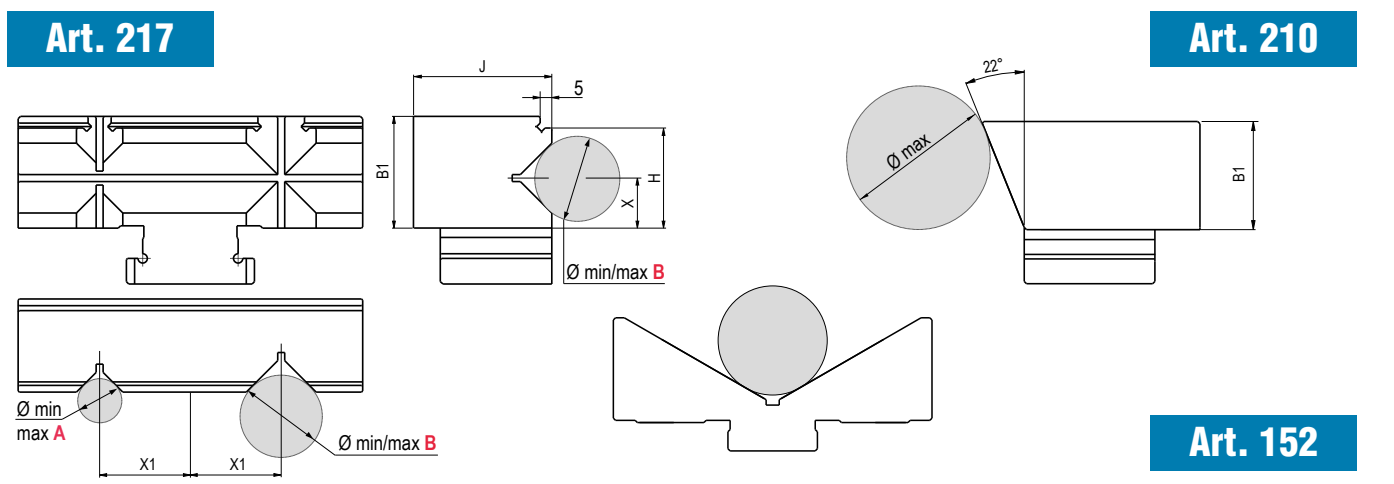
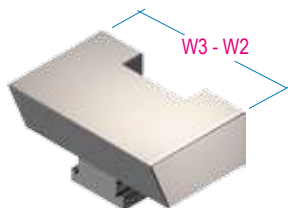

mm	1	2	3	4	5	6
W3	96	121	146	171	196	296
W2	74	94	124	144	169	194
B1	28	38	48	58	63	78
H	23	33	43	53	53	68
J	50	60	80	90	100	120
X	11,5	16,5	21,5	26,5	31,5	34
X1	25	33	39	50	50	70
Ø min / max A Art. 217	4 - 10	7 - 18	9 - 24	9 - 24	9 - 24	10 - 28
Ø min / max B Art. 217	6 - 16	9 - 24	13 - 38	15 - 40	15 - 42	18 - 46
Ø min / max Art. 152			A richiesta	On request		
Ø max Art. 210	35	50	65	80	85	105

Ganasce MOBILI OLEODINAMICHE / HYDRAULIC MOVABLE jaws

Tipo (grandezza) morsa / Vise (type) size

1 2 3 4 5 6
Art. 188

Ganascia mobile oscillante con pistoni idraulici indipendenti. Larghezza normale
 Floating movable jaw with independent hydraulic pistons. Normal width

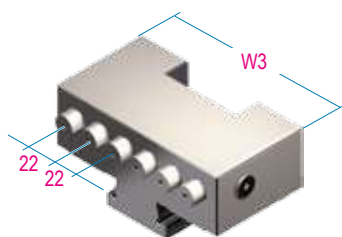

Cod. 2.18.81000 2.18.82000 2.18.83000 2.18.84000 2.18.85000 2.18.86000

Art. 254

Inserti prismatici per ganasce fisse con piastre piane. Larghezza normale
 Prismatic insert for straight fixes jaws. Normal width

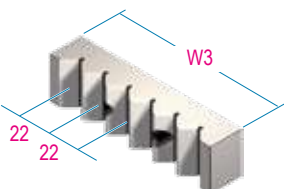
Art.188 + Art. 254

Da utilizzare insieme per il serraggio di pezzi tondi
 To be used together for round workpieces clamping

Cod. 1.25.41000 1.25.42000 1.25.43000 1.25.44000 1.25.45000 1.25.46000

Utilizzabili anche con ganasce mobili oleodinamiche Art. 188
 Used also for hydraulic movable jaws Art. 188

Art. 192

Ganascia mobile oscillante con 2 segmenti oscillanti e puntali sferici lisci.
 Floating movable jaw with two floating elements and spherical smooth points.

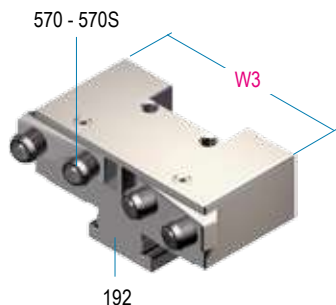

Per serraggio di particolari irregolari
 For irregular workpieces clamping

Art. 192S

Ganascia mobile oscillante con 2 elementi oscillanti e puntali sferici zigrinati.
 Floating movable jaw with two floating elements and spherical serrated points.

Cod. 4.19.21000 4.19.22000 4.19.23000 4.19.24000 4.19.25000 4.19.26000

Cod. 4.19.2S100 4.19.2S200 4.19.2S300 4.19.2S400 4.19.2S500 4.19.2S600

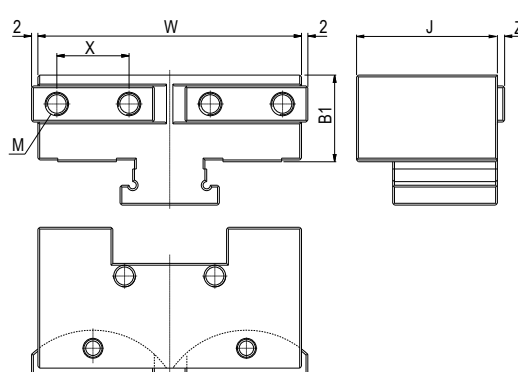
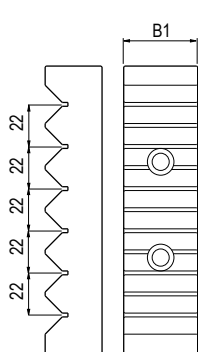
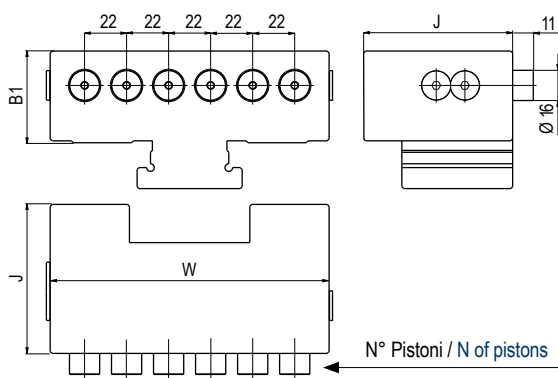
Art. 188
Art. 254
Art. 192

Art.	1	2	3	4	5	6
W3	96	121	146	171	196	296
J	48	58	78	88	98	118
B1	28	38	48	58	63	78
X	30	40	40	40	60	60
M	M10	M12	M12	M12	M16	M16
N	4	4	6	7	8	12
Z	3	4	4	4	7	7

PARALLELE MODULARI MAGNETICHE AD INNESTO RAPIDO QUICK MAGNETIC MODULAR PARALLEL PLATES

Queste piastre d'appoggio modulari parallele sono una ulteriore opportunita' del sistema modulare Gerardi. Esso consente infatti il posizionamento rapido e preciso di parallele piane o angolari per la lavorazione di pezzi piatti da forare e/o filettare.

Nessun problema di magnetismo sui trucioli

The modular bearing parallelsplates are a further opportunity of the Gerardi modular system. It allows in fact the quick and accurate positioning of straight or angular parallels plates to machine (milling, drilling and tapping) flat pieces of any size and dimension without disassembling or positioning the fixture again.
No problem with chips magnetic

VANTAGGI:

- Rapidita' e precisione di installazione.
 - Risparmio rispetto alla sostituzione della ganaschia intera.
 - Minori ingombri e costi rispetto alle parallele standard.
 - Usiamo parallele magnetiche con piastre ganasce avvitate
- Naturalmente tutti i componenti sono in acciaio speciale per molle e rettificati con tolleranze centesimali.

ADVANTAGES:

- Quick and accurate positioning.
 - Saving with respect to the substitution of the whole jaw.
 - Space and money saving with respect to the standard parallel plates.
 - Use magnetic plates with jaw plates completely tightened
- Of course each component is made of hardened and ground spring steel and the accuracy is within 0,02 mm.

ESEMPI DI APPLICAZIONE - TYPICAL ARRANGEMENTS

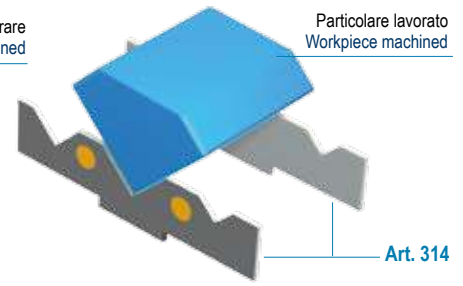
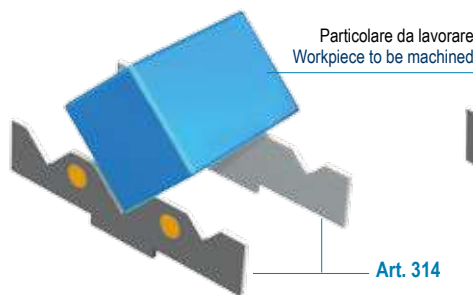
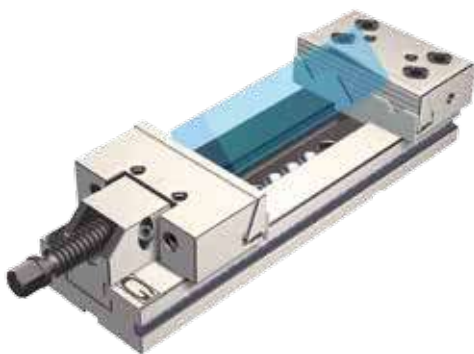
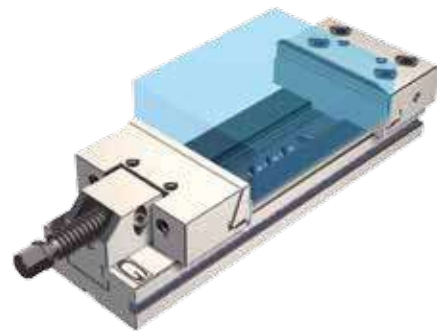

Art. 317

Rastrelliera per piastre parallele magnetiche piane e angolari
 Rak for straight and angular parallels magnetic plates

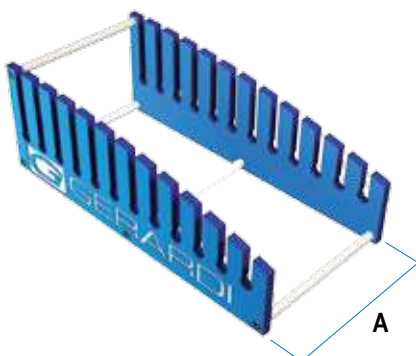

Per morse tipo (grandezza) da 1 a 6
 For vises (type) size 1 ÷ 6

A	60	70	80	100	120	150
Cod.	4.31.71000	4.31.72000	4.31.73000	4.31.74000	4.31.75000	4.31.76000

Risparmio del 33 % sulla rastrelliera Art. 317 (Vuota) se acquistata insieme al set piccolo o grande di parallele magnetiche piane o angolari!

Save 33 % purchasing the rack Art. 317 Together with the small or big set of straight magnetic parallels plates !

Tipo (grandezza) morsa / Vise (type) size

1
2
3
4
5
6
Art. 313

 Coppia di piastre parallele magnetiche piane
 Pair of straight parallels magnetic plates

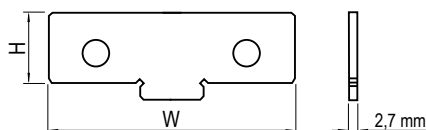
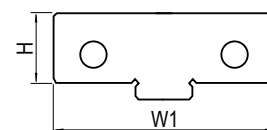
Art. 313

Art. 313R

Art. 313

W	100	125	150	175	200	300
H	23	33	43	53	53	68
Cod.	4.31.31000	4.31.32000	4.31.33000	4.31.34000	4.31.35000	4.31.36000

Art. 313R

W1	74	94	124	144	169	194
H	23	33	43	53	53	68
Cod.	4.31.3R100	4.31.3R200	4.31.3R300	4.31.3R400	4.31.3R500	4.31.3R600

Art. 313R

 Coppia di piastre parallele magnetiche piane ridotte
 Pair of straight parallels magnetic narrow plates

Art. 310
Set piccolo di piastre parallele magnetiche piane (Fino a 6 coppie)
 Small set of straight magnetic parallels plates (Max 6 pairs)

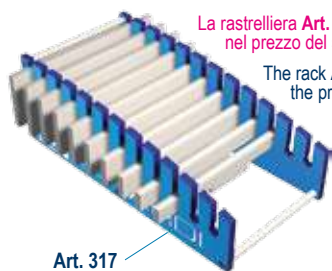
Art. 311
Set grande di piastre parallele magnetiche piane (Fino a 10 coppie)
 Big set of straight magnetic parallels plates (Max 10 pairs)

La rastrelliera Art. 317 (vuota) NON è inclusa nel prezzo del set. Vedi pag. 4.22

The rack Art. 317 (empty) is NOT included in the price of the set. See pag. 4.22

Art. 310

W	100	125	150	175	200	300
H Standard for INSERT GRIP	-	-	-	20	20	30
	-	-	15	25	25	35
	-	15	20	30	30	40
	-	20	25	35	35	45
	15	25	30	40	40	50
	18	28	35	45	45	54
	20	30	40	50	50	60
	23	33	43	53	53	68
	25	35	45	55	57	70
	27	37	47	57	60	75
Cod.	4.31.01000	4.31.02000	4.31.03000	4.31.04000	4.31.05000	4.31.06000

Art. 311

Cod.	-	-	4.31.13000	4.31.14000	4.31.15000	4.31.16000
------	---	---	------------	------------	------------	------------

Art. 314

 Coppia di piastre parallele magnetiche angolari
 Pair of angular magnetic parallels plates

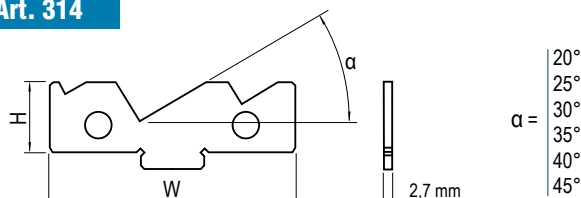
Art. 314

Art. 310

W	100	125	150	175	200	300
H	23	33	43	53	53	68
Cod.	4.31.41000	4.31.42000	4.31.43000	4.31.44000	4.31.45000	4.31.46000

Art. 312
Set di 6 coppie di piastre parallele magnetiche angolari
 Set of 6 pairs of angular magnetic parallels plates

W	100	125	150	175	200	300
α				20°		
				25°		
				30°		
				35°		
				40°		
				45°		
Cod.	4.31.21000	4.31.22000	4.31.23000	4.31.24000	4.31.25000	4.31.26000

Art. 313A

 Coppia di magneti per parallele
 Pair of magnets for parallels











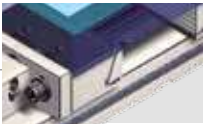

NON MODULARI - NOT MODULAR

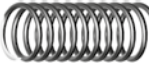
Richiedono aggiustaggio in opera - Adjustment needed before working

Cod. 4.31.3A100

Per qualsiasi parallela speciale, raddoppiare il prezzo / For special tailor made parallel double the price

ACCESSORI e parti staccate per ganasce / ACCESSORIES and loose parts for jaws

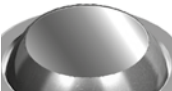
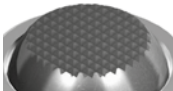
Tipo (grandezza) morsa / Vise (type) size		1	2	3	4	5	6	
Art. 132 Prolunga per ganascia mobile. Larghezza normale Extension for movable jaw. Normal width		NO StandardFLEX						
		Cod.	2.13.21000	2.13.22000	2.13.23000	2.13.24000	2.13.25000	2.13.26000
Art. 134 Prolunga per ganascia mobile. Super ridotta Extension for movable jaw. Super narrow		Cod.	2.13.41000	2.13.42000	2.13.43000	2.13.44000	2.13.45000	2.13.46000
		Art. 133 Prolunga per ganascia fissa. Larghezza normale Extension for fixed jaw. Normal width		Cod.	2.13.31000	2.13.32000	2.13.33000	2.13.34000
Art. 135 Prolunga per ganascia fissa. Ridotta e super ridotta Extension for fixed jaw. Narrow and super narrow				NO StandardFLEX				
		Cod.	2.13.51000	2.13.52000	2.13.53000	2.13.54000	2.13.55000	2.13.56000
Art. 260 Segmento oscillante per ganasce mobili. Art. 190 - 191 Floating segment for movable jaws. Art. 190 - 191		Cod.	1.26.01000	1.26.02000	1.26.03000	1.26.04000	1.26.05000	1.26.06000
		Art. 362 Molla per piastre ganasce Spring for jaw plates		Cod.	0.70.10000	0.70.20000	0.70.30000	0.70.40000
Art. 380 Vite TCEI fissaggio corpo ganascia fissa Hex socket and screw for fixed jaw body				Cod.	0.01.11030	0.01.10865	0.01.11450	0.01.11660
		Art. 381 Vite TCEI fissaggio piastra ganascia fissa Hex socket screw for fixed plate		Cod.	0.01.10565	0.01.11240	0.01.11451	0.01.11661
Art. 382 Vite TCEI fissaggio piastra ganascia mobile Hex socket and screw for movable jaw plate				Cod.	0.01.10525	0.01.10830	0.01.10840	0.01.10845
		Art. 383 Vite TCEI fissaggio piastra ganascia fissa doppia Hex socket and screw for double fixed jaw		Cod.	0.01.10520	0.01.10620	0.01.10820	0.01.11820
Art. 384 Vite TCEI per arresto laterale Hex socket and screw for workstop				Cod.	0.06.11100	0.06.22200	0.06.33300	0.06.44400
		Art. 431 Rondella per arresto laterale Washer for workstop		Cod.	2.43.11000	2.43.12000	2.43.13000	2.43.14000
Art. 440 Dado per arresto laterale Nut for workstop				Cod.	2.44.01000	2.44.02000	2.44.03000	2.44.04000
		Art. 570 Puntale sferico liscio Smooth spherical point		Cod.	1.57.01000	1.57.02000	1.57.03000	1.57.04000
Art. 570S Puntale sferico zigrinato Serrated spherical point				Cod.	1.57.0S100	1.57.0S200	1.57.0S300	1.57.0S400

CORPI GANASCE STANDARD / BODIES STANDARD JAWS

Tipo (grandezza) morsa / Vise (type) size

1	2	3	4	5	6
---	---	---	---	---	---

Art. 300

Corpo ganascia fissa. Larghezza normale
Body fixed jaw. Normal width

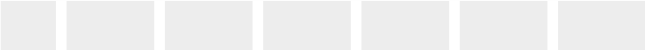

Cod.	1.35.10000	1.35.20000	1.35.30000	1.35.40000	1.35.50000	1.35.60000
------	------------	------------	------------	------------	------------	------------

Art. 301

Corpo ganascia fissa. Larghezza ridotta rettificata
Body fixed jaw. Narrow width ground

Cod.	1.35.10300	1.35.20300	1.35.30300	1.35.40300	1.35.50300	1.35.60300
------	------------	------------	------------	------------	------------	------------

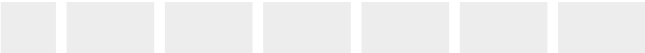
Art. 303

Corpo ganascia fissa doppia. Larghezza normale
Double body fixed jaw. Normal width



Cod.	1.35.10900	1.35.20900	1.35.30900	1.35.40900	1.35.50900	1.35.60900
------	------------	------------	------------	------------	------------	------------

Art. 304

Corpo ganascia fissa doppia. Larghezza ridotta rettificata
Double body fixed jaw. Narrow width ground

Cod.	1.35.11200	1.35.21200	1.35.31200	1.35.41200	1.35.51200	1.35.61200
------	------------	------------	------------	------------	------------	------------

Art. 306

Corpo ganascia mobile guidata. Larghezza normale
Body guided movable jaw. Normal width

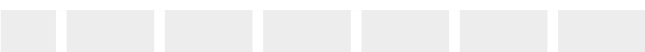

Cod.	1.36.10000	1.36.20000	1.36.30000	1.36.40000	1.36.50000	1.36.60000
------	------------	------------	------------	------------	------------	------------

Art. 307

Corpo ganascia mobile guidata. Larghezza ridotta rettificata
Body guided movable jaw. Narrow width ground

Cod.	1.36.11000	1.36.21000	1.36.31000	1.36.41000	1.36.51000	1.36.61000
------	------------	------------	------------	------------	------------	------------

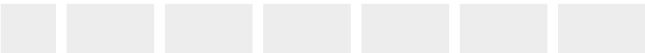
Art. 308

Corpo ganascia mobile oscillante. Larghezza normale
Body floating movable jaw. Normal width

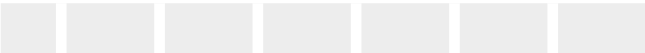

Cod.	1.36.10400	1.36.20400	1.36.30400	1.36.40400	1.36.50400	1.36.60400
------	------------	------------	------------	------------	------------	------------

Art. 309

Corpo ganascia mobile oscillante. Larghezza ridotta
Body floating movable jaw. Narrow width

Cod.	1.36.10700	1.36.20700	1.36.30700	1.36.40700	1.36.50700	1.36.60700
------	------------	------------	------------	------------	------------	------------

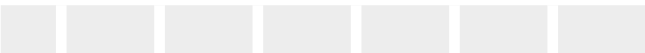
Art. 190







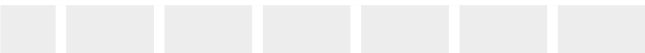

Corpo ganascia mobile oscillante
con 2 segmenti oscillanti. Larghezza normale
Body floating movable jaw
with 2 floating segments. Normal width



Cod.	2.19.01000	2.19.02000	2.19.03000	2.19.04000	2.19.05000	2.19.06000
------	------------	------------	------------	------------	------------	------------



CORPI GANASCE PIANE / BODY - STRAIGHT JAWS

Tipo (grandezza) morsa / Vise (type) size	1	2	3	4	5	6
Art. 315 Corpo ganascia fissa. Larghezza normale Body fixed jaw. Normal width 	Cod. 1.35.11800	1.35.21800	1.35.31800	1.35.41800	1.35.51800	1.35.61800
Art. 316 Corpo ganascia fissa. Larghezza ridotta rettificata Body fixed jaw. Narrow width ground 	Cod. 1.35.12100	1.35.22100	1.35.32100	1.35.42100	1.35.52100	1.35.62100
Art. 318 Corpo ganascia fissa doppia. Larghezza normale Double body fixed jaw. Normal width 	Cod. 1.35.12700	1.35.22700	1.35.32700	1.35.42700	1.35.52700	1.35.62700
Art. 319 Corpo ganascia fissa doppia. Larghezza ridotta rettificata Double body fixed jaw. Narrow width ground 	Cod. 1.35.13000	1.35.23000	1.35.33000	1.35.43000	1.35.53000	1.35.63000
Art. 321 Corpo ganascia mobile guidata. Larghezza normale Body guided movable jaw. Normal width 	Cod. 1.36.11600	1.36.21600	1.36.31600	1.36.41600	1.36.51600	1.36.61600
Art. 322 Corpo ganascia mobile guidata. Larghezza ridotta rettificata Body guided movable jaw. Narrow width ground 	Cod. 1.36.12200	1.36.22200	1.36.32200	1.36.42200	1.36.52200	1.36.62200
Art. 323 Corpo ganascia mobile oscillante. Larghezza normale Body floating movable jaw. Normal width 	Cod. 1.36.11300	1.36.21300	1.36.31300	1.36.41300	1.36.51300	1.36.61300
Art. 324 Corpo ganascia mobile oscillante. Larghezza ridotta rettificata Body floating movable jaw. Narrow width ground 	Cod. 1.36.11900	1.36.21900	1.36.31900	1.36.41900	1.36.51900	1.36.61900

CORPI GANASCE PER PIASTRE INTERCambiabili MANUALMENTE JAW BODIES FOR QUICK INTRCHANGEABLE JAW PLATES

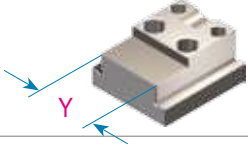
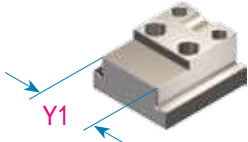
Art. 300A Corpo ganascia fissa Fixed jaw body 	Cod. 1.30.0A100	1.30.0A200	1.30.0A300	1.30.0A400	1.30.0A500	1.30.0A600
Art. 303A Corpo ganascia fissa doppia Double fixed jaw body 	Cod. 1.30.3A100	1.30.3A200	1.30.3A300	1.30.3A400	1.30.3A500	1.30.3A600
Art. 306A Corpo ganascia mobile guidata Guided movable jaw body 	Cod. 1.30.6A100	1.30.6A200	1.30.6A300	1.30.6A400	1.30.6A500	1.30.6A600
Art. 306B Pattino per ganasce mobili guidate Sliding plate for guided movable jaw 	Cod. 1.30.6B100	1.30.6B200	1.30.6B300	1.30.6B400	1.30.6B500	1.30.6B600
Art. 306C Pattino per ganasce mobili oscillanti Sliding plate for floating movable jaw 	Cod. 1.30.6C100	1.30.6C200	1.30.6C300	1.30.6C400	1.30.6C500	1.30.6C600

Y1 = Y - 1mm

GRUPPI PREASSEMBLATI / PRE-ASSEMBLED GROUP

Tipo (grandezza) morsa / Vise (type) size	1	2	3	4	5	6
Art. 105 Base girevole Swivel base	Ø B 180	225	290	320	370	400
	C 50	52	65	80	94	116
	D 112	146	175	200	220	240
	E 155	195	245	272	310	340
	F 20	23	28	28	34	38
	G 11	14	20	20	25	25
	H 6,5	8,5	12,5	12,5	17	17
	L 7	10	13	13	17	17
	M 12	14	20	20	26	26
	N 10	13	16	16	20	20
	O 6,5	8,5	12,5	12,5	16,5	16,5
	kg 3,3	5,5	10,8	13	21	25,3
	Cod. 2.10.51000	2.10.52000	2.10.53000	2.10.54000	2.10.55000	2.10.56000

Art. 105 - Senza alcuna dotazione
Art. 105 - Supplied without accessory equipment

Art. 365 Anello esterno per base girevole Outer ring swivel base		Cod. 1.81.11000	1.81.21000	1.81.31000	1.81.41000	1.81.51000	1.81.61000
Art. 366 Anello interno per base girevole Inner ring swivel base		Cod. 1.81.12000	1.81.22000	1.81.32000	1.81.42000	1.81.52000	1.81.62000
Art. 367 Staffa per base girevole Clamp swivel base		Cod. 1.84.10000	1.84.20000	1.84.30000	1.84.40000	1.84.50000	1.84.60000
Art. 368 Spina cilindrica per base girevole Straight pin swivel base		Cod. 0.80.11000	0.80.21000	0.80.31000	0.80.41000	0.80.51000	0.80.61000
Art. 420 Vite esagonale per base girevole Bolt swivel base		Cod. 0.05.08035	0.05.10035	0.05.10040	0.05.12050	0.05.14060	0.05.14060
Art. 430 Rondella per base girevole Washer swivel base		Cod. 0.75.18416	0.75.11052	0.75.11052	0.75.11325	0.75.11525	0.75.11525

Art. 105 Base girevole / Swivel base
(Art. 365 + 366 + 367 + 368 + 420 + 430)

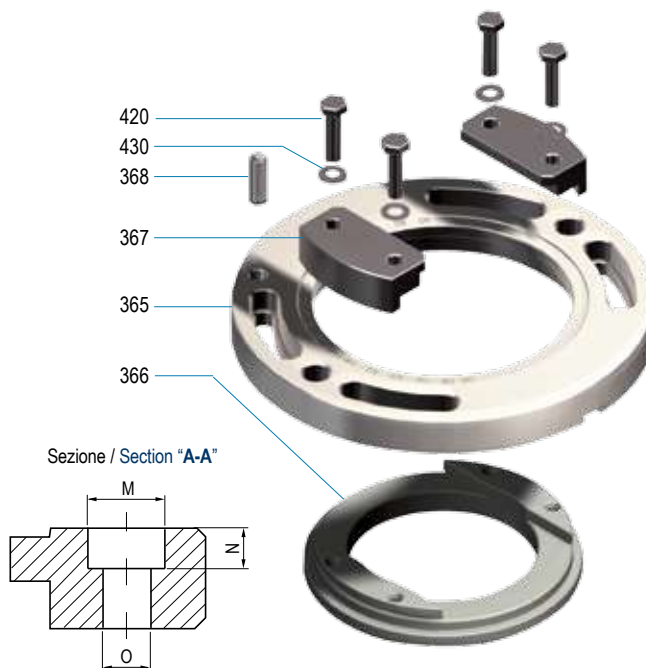
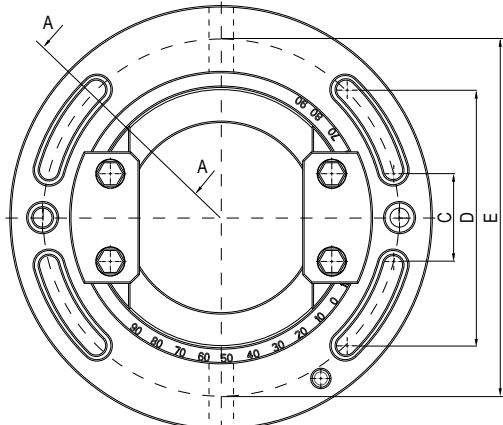
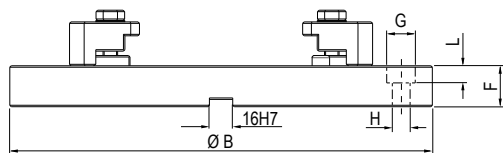

Art.	Pag.
365	4.27
366	4.27
367	4.27
368	4.27
420	4.27
430	4.27
-	-
-	-
-	-
-	-
-	-

GRUPPI PREASSEMBLATI / PRE-ASSEMBLED GROUP

4

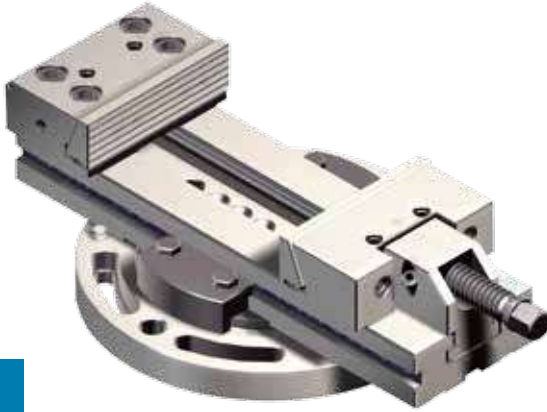

Art. 2

Morsa STD Art. 1 + Base girevole Art.105
Art. 1 STD vise + Swivel base Art.105



Art. 2A

Morsa STD Art. 1A + Base girevole Art.105
Art. 1A STD vise + Swivel base Art.105

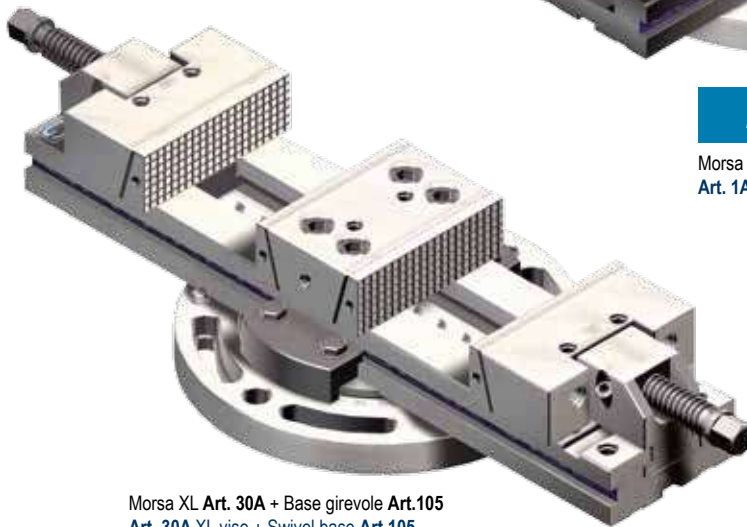

Morsa XL Art. 30A + Base girevole Art.105
Art. 30A XL vise + Swivel base Art.105

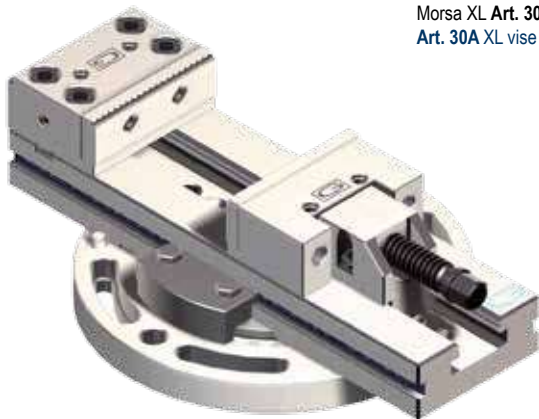

Morsa STD Art. 15 + Base girevole Art.105
Art. 15 STD vise + Swivel base Art.105



Art. 2

Morsa STD Art. 1 + Base girevole Art.105
Art. 1 STD vise + Swivel base Art.105

STAFFE DI ANCORAGGIO PER MORSE / VISE HOLDING CLAMPING

Art. 296

Coppia di staffe Art. 298 complete di vite e dado a T (Art. 287) / Pair of vise holding clamps Art. 298 complete of screws and T nuts (Art. 287)

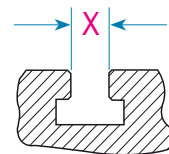
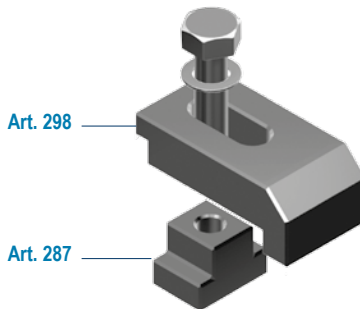
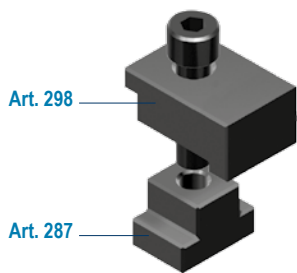

Specificare sempre la cava della vostra macchina

Always specify the machine T-slot dimension

Morse / Vises		Tipo (grandezza) morse / Vise (type) size							
STD	1	1 - 2		3 - 4		5 - 6			
FMS	1	1		2 - 3		4 - 5 - 6			
MULTIFLEX	1	1		2 - 3		--			
MULTITASKING	-	3		-					
COMPACT GRIP	-	1 - 2 - 3		-					
Staffe / Holding Clamps	1 x M8	1 x M10	1 x M12	1 x M16	2 x M12	2 x M16	3 x M12	3 x M16	
Cod.	2.29.61000 / M8	2.29.61000 / M10	2.29.61000 / M12	2.29.61000 / M16	2.29.63000 / M12	2.29.63000 / M16	2.29.65000 / M12	2.29.65000 / M16	

Art. 298

Staffe di ancoraggio per morse (Venduta singolarmente) / Vise holding clamps (Single)

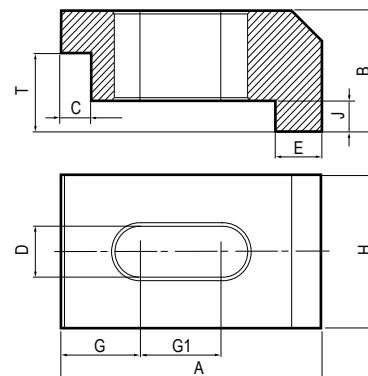
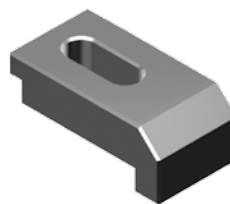
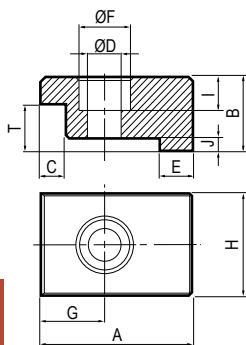
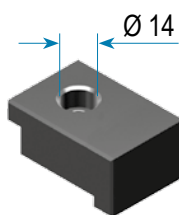

Solo per tipo 1 x M8
Only for type 1 x M8

Morse / Vises		Tipo (grandezza) morse / Vise (type) size							
STD	1	1 - 2		3 - 4		5 - 6			
FMS	1	1		2 - 3		4 - 5 - 6			
MULTIFLEX	1	1		2 - 3		--			
MULTITASKING	-	3		-					
COMPACT GRIP	-	1 - 2 - 3		-					
Staffe / Holding Clamps	1 x M8	1 x M10	1 x M12	1 x M16	2 x M12	2 x M16	3 x M12	3 x M16	
A	50	50	50	50	76	76	86	86	
B	24	24	24	24	30	30	40	40	
C	6	6	6	6	6	6	10	10	
Ø D	8,5	11	13	17	13	17	13	17	
E	10	10	10	10	13	13	15	15	
Ø F	14	-	-	-	-	-	-	-	
G / G1	17	16 / 15	17,5 / 13	19 / 9	17 / 22	16 / 15	26 / 27	26 / 27	
H	34	34	34	34	42	42	50	50	
I	8	10	10	10	-	-	-	-	
J	4	4	4	4	10	10	10	10	
T ± 0,1	15	15	15	15	20	20	26	26	
Cod.	2.29.81000 / M8	2.29.81000 / M10	2.29.81000 / M12	2.29.81000 / M16	2.29.83000 / M12	2.29.83000 / M16	2.29.85000 / M12	2.29.85000 / M16	

Art. 287

 Dadi per cave a T
 Nuts for T slots

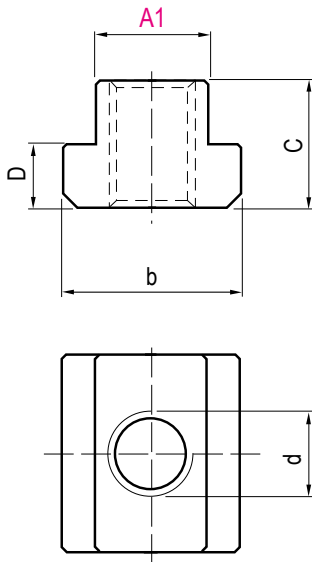
DIN 508

 In fase d'ordine,
 completare il codice
 specificando il
 numero **N** di dado a T

 In the purchase order
 specify the **N** number
 of the T nut in the code

Esempio / Example

Cod. 2.28.74000 / 24

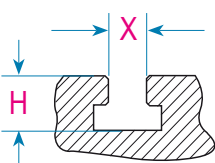
DIN 650

 Specificare sempre la cava
 della vostra macchina

 Always specify
 the machine T-slot dimension

N	d	A1	b	C	D	N	d	A1	b	C	D
01	M5 x 6	5,7	10	8	4	31	M14 x 24	23,7	40	32	16
02	M5 x 8	7,7	13	10	5	32	M16 x 18	17,7	28	20	10
03	M5 x 10	9,7	15	12	6	33	M16 x 20	19,7	32	24	12
04	M6 x 8	7,7	13	10	5	34	M16 x 22	21,7	35	28	14
05	M6 x 10	9,7	15	12	6	35	M16 x 24	23,7	40	32	16
06	M6 x 12	11,7	18	14	7	36	M16 x 28	27,7	44	36	18
07	M8 x 10	9,7	15	12	6	37	M16 x 30	29,7	48	38	19
08	M8 x 12	11,7	18	14	7	38	M16 x 36	35,6	54	44	22
09	M8 x 14	13,7	22	16	8	39	M18 x 20	19,7	32	24	12
10	M8 x 16	15,7	25	18	9	40	M18 x 22	21,7	35	28	14
11	M8 x 18	17,7	28	20	10	41	M18 x 24	23,7	40	32	16
12	M10 x 12	11,7	18	14	7	42	M18 x 28	27,7	44	36	18
13	M10 x 14	13,7	22	16	8	43	M18 x 30	29,7	48	38	19
14	M10 x 16	15,7	25	18	9	44	M18 x 36	35,6	54	44	22
15	M10 x 18	17,7	28	20	10	45	M20 x 22	21,7	35	28	14
16	M10 x 20	19,7	32	24	12	46	M20 x 24	23,7	40	32	16
17	M10 x 22	21,7	35	28	14	47	M20 x 28	27,7	44	36	18
18	M10 x 24	23,7	40	32	16	48	M20 x 30	29,7	48	38	19
19	M12 x 14	13,7	22	16	8	49	M20 x 36	35,6	54	44	22
20	M12 x 16	15,7	25	18	9	50	M20 x 42	41,6	65	52	26
21	M12 x 18	17,3	28	20	10	51	M20 x 48	47,6	75	60	30
22	M12 x 20	19,7	32	24	12	52	M24 x 28	27,7	44	36	18
23	M12 x 22	21,7	35	28	14	53	M24 x 30	29,7	48	38	19
24	M12 x 24	23,7	40	32	16	54	M24 x 36	35,6	54	44	22
25	M12 x 28	27,7	44	36	18	55	M24 x 42	41,6	65	52	26
26	M12 x 30	29,7	48	38	19	56	M24 x 48	47,6	75	60	30
27	M14 x 16	15,7	25	18	9	57	M30 x 36	35,6	54	44	22
28	M14 x 18	17,7	28	20	10	58	M30 x 42	41,6	65	52	26
29	M14 x 20	19,7	32	24	12	59	M30 x 48	47,6	75	60	30
30	M14 x 22	21,7	35	28	14	60	M30 x 54	53,6	85	70	35
X		0 ÷ 22		23 ÷ 36		37 ÷ 54					
Cod.		2.28.72000 / N		2.28.740000 / N		2.28.76000 / N					

ATTREZZI e DOTAZIONI / TOOLS and EQUIPMENT

Tipo (grandezza) morsa / Vise (type) size	1	2	3	4	5	6
---	---	---	---	---	---	---

Art. 297

Coppia di tasselli di posizionamento completi di vite M5 x 10 / **Specificare sempre quota B**
 Pair of positioning key-nuts with M5 x 10 clamping screw / **Specify always B dimension**



Altri tipi e misure
 fornibili a richiesta
 Other types and dimensions
 available on request

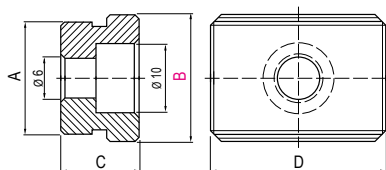

A	16									
B	10	12	14	16	18	20	22	24	28	36
C	10	10	10	10	10	12	12	12	12	12
D	25									
Cod.	2.29.71000									

Art. 291

Tappo incavo per alloggiamento sfera **solo per Art.1A**
 Concave cap for sphere **only for Art.1A**



Ø	21	25	25	25	25	25
Cod.	1.29.11000	1.29.12000	1.29.13000	1.29.14000	1.29.15000	1.29.16000

Art. 325

Chiave esagonale a bussola
 Hexagon bushing



CH	14	16	17	18	19	21
Cod.	0.09.32514	0.09.32516	0.09.32517	0.09.32518	0.09.32519	0.09.32521
CH	22	24	27	30	32	-
Cod.	0.09.32522	0.09.32524	0.09.32527	0.09.32530	0.09.32532	-

Art. 370

Arresto laterale completo
 Complete workstop

Art. 370

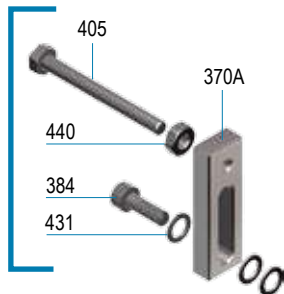

Cod.	2.37.01000	2.37.03000	2.37.05000
------	------------	------------	------------

Art. 405

Vite principale per arresto laterale (Ricambio)
 Main bolt for workstop (Spare)

Cod.	1.77.10120	1.77.16180
------	------------	------------

Art. 370A

Staffa per arresto laterale (Ricambio)
 Klamps for workstop (Spare)

Cod.	2.37.0A100	2.37.0A300	2.37.0A500
------	------------	------------	------------

Art. 375

Chiave a pipa
 Box wrench

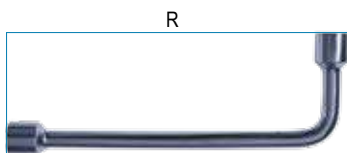

CH	12	19	22	30
R	200	250	285	480
Cod.	0.09.41160	0.09.42180	0.09.43320	0.09.43360

Art. 376

Chiave a T
 T wrench



CH	4	5	6	10
Cod.	0.09.21400	0.09.22500	0.09.23600	0.09.25100

Art. 377

Chiave esagonale serie lunga
 Hexagon wrench long reach

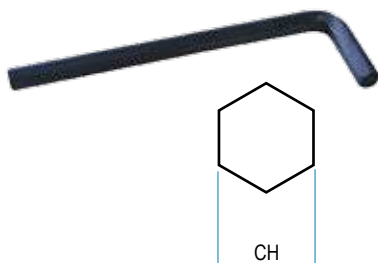

CH	2	2,5	3	3,5	4	4,5
Cod.	0.09.37702	0.09.37725	0.09.37703	0.09.37735	0.09.37704	0.09.37745
CH	5	6	7	8	9	10
Cod.	0.09.37705	0.09.37706	0.09.37707	0.09.37708	0.09.37709	0.09.37710
CH	12	13	14	17	19	-
Cod.	0.09.37712	0.09.37713	0.09.37714	0.09.37717	0.09.37719	-

Tipo (grandezza) morsa / Vise (type) size	1	2	3
---	---	---	---

Art. 357

Chiave dinamometrica digitale a
 cricchetto con attacco 1/2"
 Torque wrench digital ratchet type with
 hexagon with 1/2" driver square



Nm	10÷135	20÷200	34÷340
Cod.	2.35.71000	2.35.72000	2.35.73000

DISPOSITIVI MECCANICI / MECHANICAL BLOCKING DEVICES

Tipo (grandezza) morsa / Vise (type) size	1	2	3	4	5	6
Art. 258						
Gruppo di serraggio meccanico completo senza accessori Mechanical clamping device complete No accessories						
						
kg	0,4	1	1,9	2,9	5,3	7,8
Cod.	2.25.81000	2.25.82000	2.25.83000	2.25.84000	2.25.85000	2.25.86000

 Per le forze di serraggio vedi pag. 4.00
 For clamping force see page 4.00

RICAMBI / SPARE PARTS
Art. 360

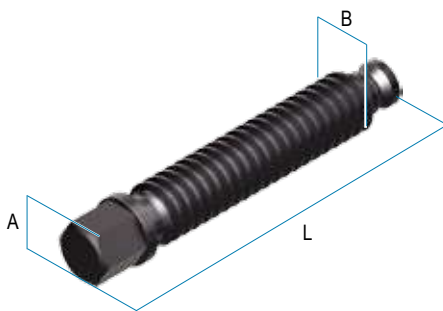
 Vite di spinta. Normale
 Clamping bolt. Normal

A	12	19	22	30
B	M12	TPN 18 x 4	TPN 24 x 5	TPN 30 x 5
L	100	130	150	190
Cod.	1.90.10144	1.90.20184	1.90.30245	1.90.50366

Art. 355

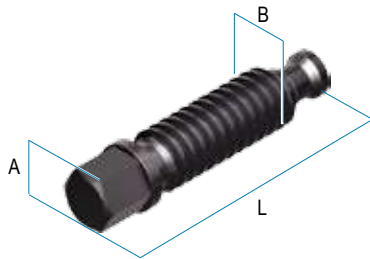
 Vite di spinta. Ridotta
 Clamping bolt. Short

A	12	19	22	30
B	M12	TPN 18 x 4	TPN 24 x 5	TPN 30 x 5
L	90	100	115	150
Cod.	1.90.14144	1.90.24184	1.90.34245	1.90.54366

Art. 356

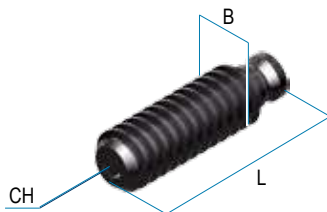
 Vite di spinta. Super ridotta
 Clamping bolt. Super short

CH	6	8	10	12
B	M12	TPN 18 x 4	TPN 24 x 5	TPN 30 x 5
L	53	73	81	113
Cod.	1.35.61000	1.35.62000	1.35.60003	1.35.60005

Art. 282

 Supporto di serraggio meccanico
 Mechanical clamping device support

Cod.	2.28.21000	2.28.22000	2.28.23000	2.28.24000	2.28.25000	2.28.26000

Art. 410

 Grano
 Setscrew

	0.06.20810	0.06.21012	0.06.21216	0.06.21620	0.06.21630	0.06.31360
Cod.	M8 x 20	M10 x 25	M12 x 30	M12 x 40	M20 x 50	M20 x 50
	CH. 3	CH. 5	CH. 6	CH. 6	CH. 10	CH. 10

Art. 361

 Sfera
 Ball

Cod.	1.36.11001	1.36.12002	1.36.13003	1.36.14004	1.36.15005	1.36.16006
	9/16"	3/4"	7/8"	7/8"	1 1/8"	1 1/8"

SERVOCOMANDI OLEODINAMICI / HYDRAULIC SERVO UNITS

Tipo (grandezza) morsa / Vise (type) size	1	2	3	4	5	6
Art. 257 Gruppo di serraggio a vite idraulica (Autonomo) Hydraulic hand screw clamping device (Self contained)						
Cod.	-	2.25.73000	2.25.74000	2.25.75000	2.25.76000	
Art. 284 Supporto di serraggio per mandrino a vite idraulica Clamping support for hydraulic spindle						
Cod.	-	2.28.43000	2.28.44000	2.28.45000	2.28.46000	
Art. 286 Mandrino a vite idraulica Hydraulic spindle						
Kn	-		12		20	
A	-		420		359	
Cod.	-		4.28.63000		4.28.65000	
Art. 295 Gruppo di serraggio a vite idraulica compatto Compact hydraulic hand screw clamping device						
Cod.	-	4.29.53000	4.29.54000	-	-	
Art. 294 Supporto di serraggio per mandrino compatto a vite idraulica Clamping support for compact hydraulic spindle						
Cod.	-	4.29.43000	4.29.44000	-	-	
Art. 293 Mandrino compatto a vite idraulica Compact hydraulic spindle						
Kn	-		10		-	
A	-		173			
Cod.	-		4.29.33000	4.29.34000	-	-
Art. 290 Manovella per mandrino a vite idraulica Crank hydraulic spindle						
Cod.	-			0.09.73000		
Art. 292 Prolunga per Art. 290 Extension for Art. 290						
A		160 / 260				
Cod.	-			4.29.23000		

METODI ALTERNATIVI DI SERRAGGIO

ALTERNATIVE CLAMPING OPTION

Il gruppo di serraggio a vite idraulica, è un moltiplicatore di forza manuale alternativo al gruppo di serraggio meccanico **Art. 258**; Tale dispositivo consente di applicare la medesima forza di serraggio della vite manuale con uno sforzo minore.

Il mandrino a vite idraulica è azionato manualmente tramite l'apposita manovella in dotazione **Art. 290**.

Verificare che il vano tra ganaschia mobile **A** e supporto vite **B** sia pulito, in modo che il mandrino idraulico possa scorrere liberamente senza impedimenti che potrebbero causare attriti e di conseguenza minor forza di serraggio.

Ruotare in senso orario il mandrino utilizzando la manovella in dotazione **Art. 290**, muovendo la ganaschia mobile **A** in avanti fino al contatto con il pezzo da serrare. Un' ulteriore rotazione farà scattare la frizione e di conseguenza da quel momento inizia la forza di spinta idraulica e mentre il mandrino rimane fermo, avanza la vite **1** che spinge lo stantuffo **2** nella camera d'olio **3** generando pressione. Dopo il precarico meccanico **ogni giro di manovella genera una forza K. Quando il mandrino arriva in battuta, sviluppa la massima forza possibile.**

4

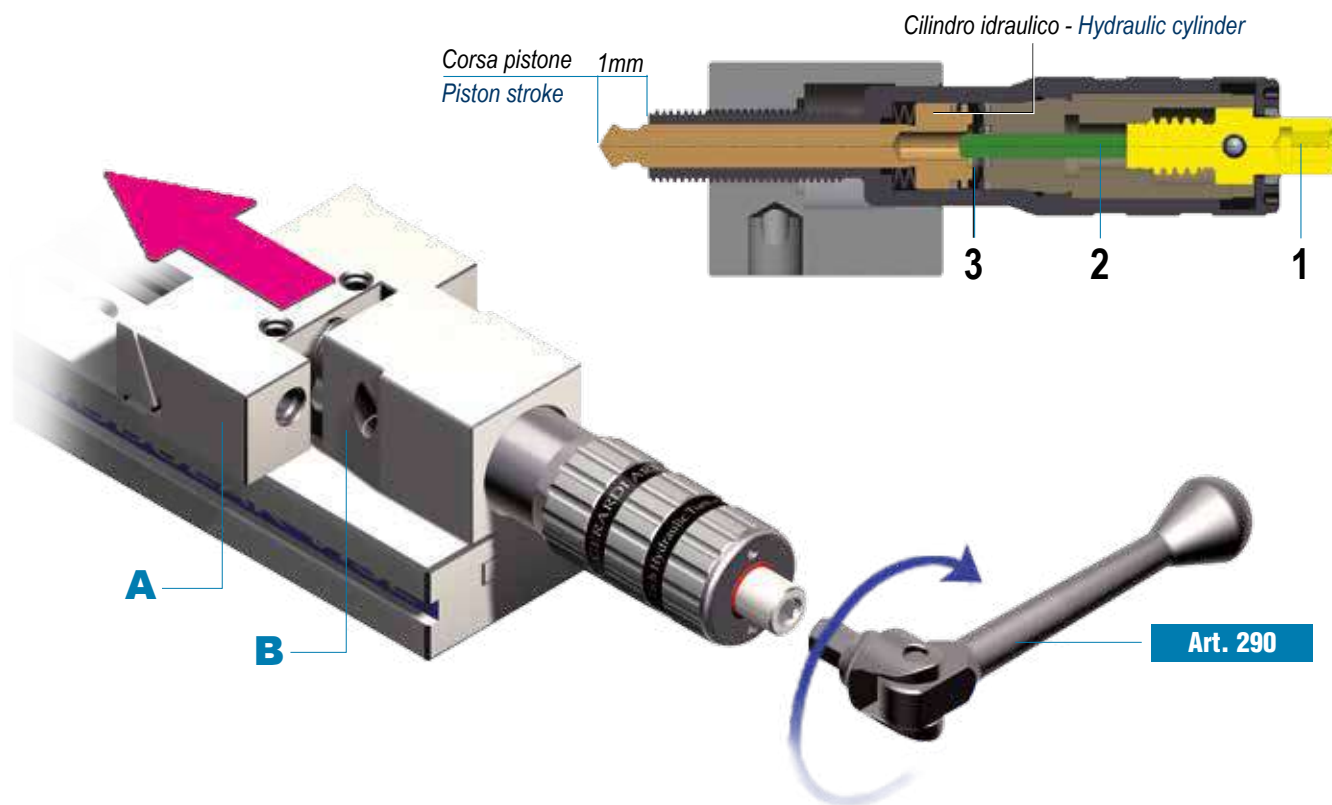

ATTENZIONE !
 Quando il mandrino arriva in battuta, una ulteriore pressione sviluppata sulla manovella (Art. 290) potrebbe danneggiare in modo irreparabile il moltiplicatore.

ATTENTION !
 When the spindle reach the end of his stroke, a further pressure on the wrench (Art. 290) can seriously damage the pressure multiplier

The hand hydraulic clamping group is a manual power multiplier alternative to the mechanical clamping group **Art.258**. This device allows to reach the same clamping power reachable with the mechanical screw through a minimum effort. The hand hydraulic screw is manually operated by the proper wrench **Art.290**. Make sure that space between the movable jaw **A** and the main spindle support **B** is clean so that the hydraulic spindle can move freely without chips inside causing frictions and consequently less clamping power.

Turn clockwise the spindle using the wrench **Art. 290** supplied in the standard equipment until the movable jaw **A** touches workpiece. A further rotation will start the power multiplier action; at every spindle turn an increasing clamping power will be applied to the workpiece. A further rotation will make the crank slip and the hydraulic power will start. The hydraulic spindle will stop turning but the screw **1** will move forward to push the small piston **2** into the oil chamber **3** creating an overpressure and obviously clamping force. After the mechanical pre-loading **each turn of the wrench produce a K force** **When the spindle reaches the end of its possible run it reaches its max possible power.**

DIAGRAMMI SERRAGGIO MECCANICO CON CHIAVE DINAMOMETRICA DIAGRAMS MECHANICAL CLAMPING WITH TORQUE WRENCH



GRUPPI DI SERRAGGIO IDRAULICI

(Art. 257 - Art.295)

I diagrammi seguenti consentono di determinare le forze di serraggio ottenibili con le i seguenti gruppi di serraggio idraulici di varia grandezza (da 1 a 6), in funzione del momento applicato

HYDRAULIC CLAMPING DEVICES

(Art. 257 - Art. 295)

The following diagrams give the clamping force that can be obtained with each hydraulic clamping devices type (size 1 to 6) depending on the torque

Art. 257

Autonomo - Self contained

Gruppo di serraggio a Vite Idraulica TIPO 3/4
Hydraulic hand screw clamping device TYPE

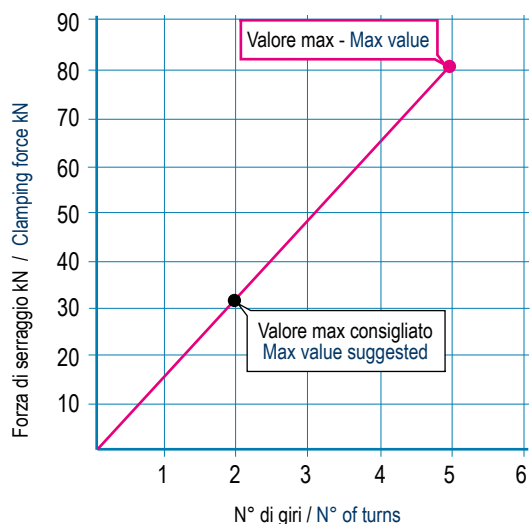

Art. 257

Autonomo - Self contained

Gruppo di serraggio a Vite Idraulica TIPO 5/6
Hydraulic hand screw clamping device TYPE

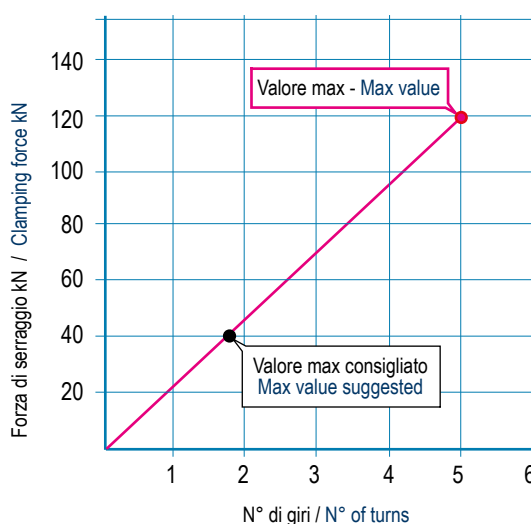

Art. 295

Compatto - Compact

Gruppo di serraggio a Vite Idraulica TIPO 3/4
Hydraulic hand screw clamping device TYPE

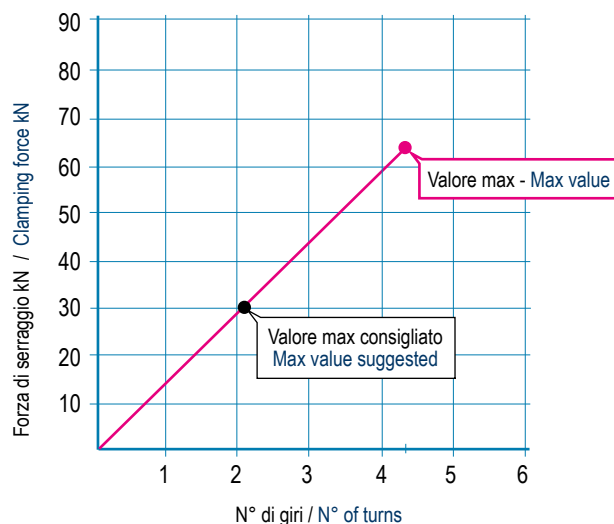

SERVOCOMANDI OLEODINAMICI / HYDRAULIC SERVO UNITS

Tipo (grandezza) morsa / Vise (type) size	1	2	3	4	5	6
---	---	---	---	---	---	---

Art. 271

Supporto di serraggio con cilindro idraulico
Clamping support with hydraulic cylinder
SEMPLICE EFFETTO - SIMPLE EFFECT



Cod.	2.27.11000	2.27.12000	2.27.13000	2.27.14000	2.27.15000	2.27.16000
Corsa Stroke	30	40				

Art. 271D

NEW!

Supporto di serraggio con cilindro idraulico
Clamping support with hydraulic cylinder
DOPPIO EFFETTO - DOUBLE EFFECT

Cod.	2.27.1D100	2.27.1D200	2.27.1D300	2.27.1D400	2.27.1D500	2.27.1D600
Corsa Stroke	30	40				

Art. 283

Supporto di serraggio per cilindro idraulico
Clamping support for hydraulic cylinder



Cod.	2.28.31000	2.28.32000	2.28.33000	2.28.34000	2.28.35000	2.28.36000
------	------------	------------	------------	------------	------------	------------

Art. 285

Cilindro idraulico a semplice effetto.
Serraggio idraulico e apertura meccanica
Hydraulic cylinder single acting.
Hydraulic clamping and mechanical opening



Cod.	2.28.51000	2.28.52000	2.28.53000	2.28.55000
------	------------	------------	------------	------------

Art. 569

Cilindro idraulico a doppio effetto. Apertura e chiusura idrauliche
Hydraulic cylinder double acting. Hydraulic opening and clamping



Cod.	1.56.91000	1.56.92000	1.56.93000	1.56.95000
------	------------	------------	------------	------------

Specifico per sistemi robotizzati - Specific for robotic applications

Esempi di applicazione / Typical arrangements

Cilindri idraulici montati su morse STD
Hydraulic cylinder assembled on STD vises

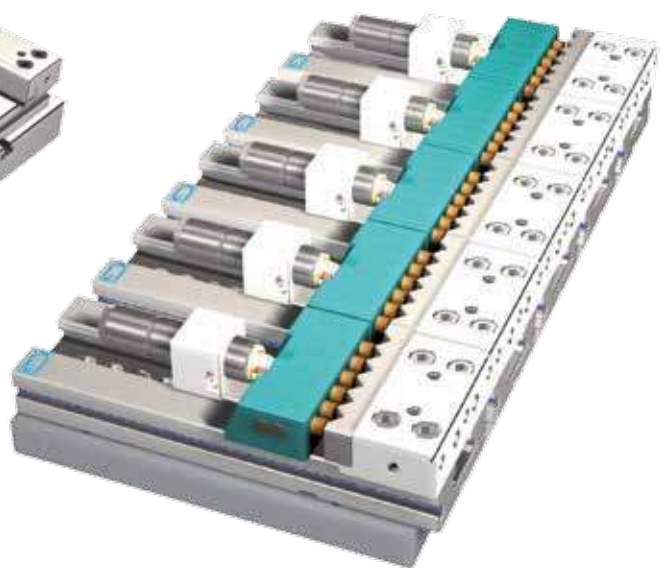
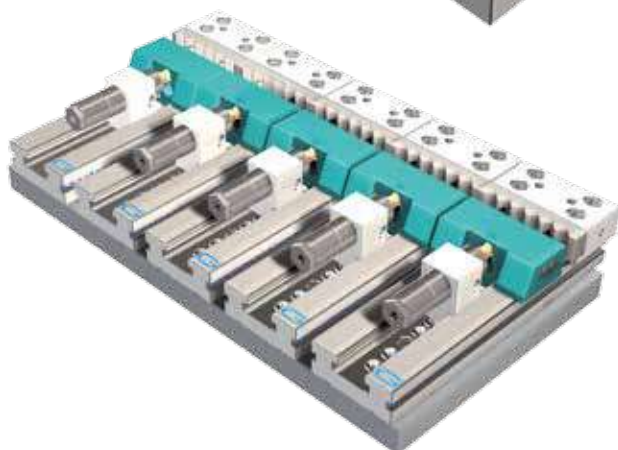

Cilindri idraulici assemblati con ganasce oleodinamiche **Art.188** per serraggi in serie di particolari tondi in verticale
Hydraulic cylinders assembled with oleodynamic jaws **Art.188** for clamping of multiple round workpieces in vertical

Parti di ricambio per CILINDRI IDRAULICI / Spare part for HYDRAULIC CYLINDER

Cilindro diametro esterno (mm) / Cylinder outside diameter (mm)	T1	T2	T3 & T4	T5 & T6
	30	40	40	50
Art. 285 Cilindro idraulico a semplice effetto Single acting hydraulic cylinder				
Art. 285A Cilindro / Cylinder	Cod. 4.28.5A100	4.28.5A200	4.28.5A300	4.28.5A500
Art. 285B Guarnizione pistone / Piston seal	Cod. 4.28.5B100	4.28.5B200	4.28.5B300	4.28.5B500
Art. 285C Pistone / Piston	Cod. 4.28.5C100	4.28.5C200	4.28.5C300	4.28.5C500
Art. 285D Molla / Spring	Cod. 4.28.5D100	4.28.5D200	4.28.5D300	4.28.5D500
Art. 285E Bussola / Bushing	Cod. 4.28.5E100	4.28.5E200	4.28.5E300	4.28.5E500
Art. 285F Ghiera / Blocking nut	Cod. 4.28.5F100	4.28.5F200	4.28.5F300	4.28.5F500
Art. 285G Guarnizione / Seal	Cod. 4.28.5G100	4.28.5G200	4.28.5G300	4.28.5G500
Art. 285H Anello guida / Guiding ring	Cod. 4.28.5H100	4.28.5H200	4.28.5H300	4.28.5H500
Diametro filettato cilindro / Cylinder O.D.	30	40	40	50
Corsa / Stroke	30	40	40	40
Area effettiva del cilindro / Cylinder effective area	3	7	7	9,6
Pressione max. d'esercizio / Max operating pressure: bar (1 bar = 14,5 psi)	450			
Pressione max. d'esercizio / Max operating pressure: psi (1 psi = 0,069 bar)	6525			

Cilindro diametro esterno (mm) / Cylinder outside diameter (mm)	T1	T2	T3 & T4	T5 & T6
	30	40	40	50
Art. 569 Cilindro idraulico a doppio effetto Double acting hydraulic cylinder				
Art. 569A Cilindro / Cylinder	Cod. 4.56.9A100	4.56.9A200	4.56.9A300	4.56.9A500
Art. 285B Guarnizione pistone / Piston seal	Cod. 4.28.5B100	4.28.5B200	4.28.5B300	4.28.5B500
Art. 569B Prolunga cilindro / Cylinder extension	Cod. 4.56.9B100	4.56.9B200	4.56.9B300	4.56.9B500
Art. 569C Pistone / Piston	Cod. 4.56.9C100	4.56.9C200	4.56.9C300	4.56.9C500
Art. 569D Anello guida / Guiding ring	Cod. 4.56.9D100	4.56.9D200	4.56.9D300	4.56.9D500
Art. 569E Raschiatore / Scraping seal	Cod. 4.56.9E100	4.56.9E200	4.56.9E300	4.56.9E500
Art. 569F Guarnizione cilindro / Cylinder seal	Cod. 4.56.9F100	4.56.9F200	4.56.9F300	4.56.9F500
Art. 569G Guarnizione / Seal	Cod. 4.56.9G100	4.56.9G200	4.56.9G300	4.56.9G500
Art. 285H Anello guida / Guiding ring	Cod. 4.28.5H100	4.28.5H200	4.28.5H300	4.28.5H500
Diametro filettato cilindro / Cylinder O.D.	30	40	40	50
Corsa / Stroke	20	33	33	40
Area effettiva del cilindro / Cylinder effective area	3	7	7	9,6
Pressione max. d'esercizio / Max operating pressure: bar (1 bar = 14,5 psi)	450			
Pressione max. d'esercizio / Max operating pressure: psi (1 psi = 0,069 bar)	6525			

COMANDO MANUALE singolo effetto / single effect MANUAL CONTROL

Tipo (grandezza) morsa / Vise (type) size	1	2	3	4	5	6
---	---	---	---	---	---	---

Art. 390

N° 1 serraggio
N° 1 clamping

MORSA NON COMPRESA
WISE NOT INCLUDED

Art. 393 + Art. 271 + Art. 403 (m 1,5)

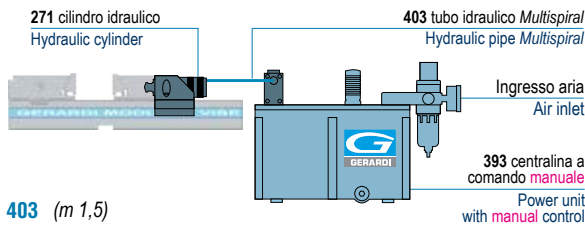

Cod. 4.39.01000 4.39.02000 4.39.03000 4.39.04000 4.39.05000 4.39.06000

--	--	--	--	--	--	--

Art. 390/2

N° 2 serraggi contemporanei
N° 2 simultaneously clamping

Art. 390 + n° 1 Art. 271

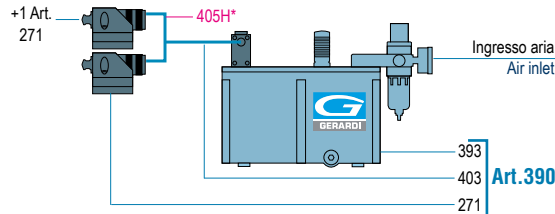

Cod. 4.39.01002 4.39.02002 4.39.03002 4.39.04002 4.39.05002 4.39.06002

--	--	--	--	--	--	--

* Non incluso (Pag. 4.38) / Not included (Pag. 4.38) 405H*

Art. 390/3

N° 3 serraggi contemporanei
N° 3 simultaneously clamping

Art. 390 + n° 2 Art. 271

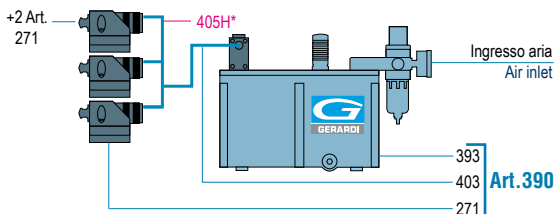

Cod. 4.39.01003 4.39.02003 4.39.03003 4.39.04003 4.39.05003 4.39.06003

--	--	--	--	--	--	--

* Non incluso (Pag. 4.38) / Not included (Pag. 4.38)

Art. 390/4

N° 4 serraggi contemporanei
N° 4 simultaneously clamping

Art. 390 + n° 3 Art. 271

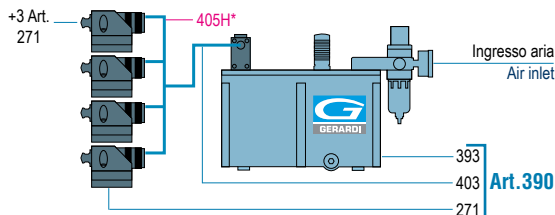

Cod. 4.39.01004 4.39.02004 4.39.03004 4.39.04004 4.39.05004 4.39.06004

--	--	--	--	--	--	--

* Non incluso (Pag. 4.38) / Not included (Pag. 4.38)

Art. 407

Gruppo di serraggio indipendente
Independent clamping group

Art. 271 + Art. 397 + Art. 403 (m 1,5)

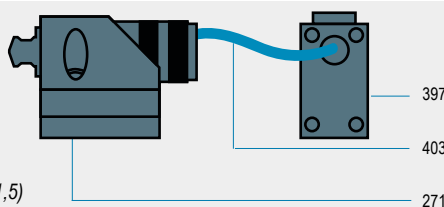

Cod. 4.40.71000 4.40.72000 4.40.73000 4.40.74000 4.40.75000 4.40.76000

--	--	--	--	--	--	--

Art. 390A / 2

N° 2 serraggi indipendenti
N° 2 independent clamping

Art. 390 + n° 1 Art. 407

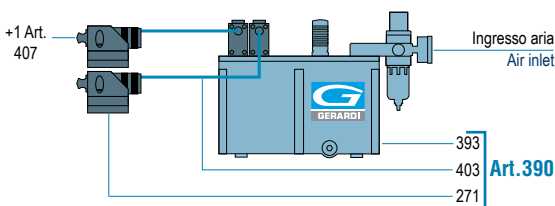

Cod. 4.39.0A102 4.39.0A202 4.39.0A302 4.39.0A402 4.39.0A502 4.39.0A602

--	--	--	--	--	--	--

Art. 390A / 3

N° 3 serraggi indipendenti
N° 3 independent clamping

Art. 390 + n° 2 Art. 407

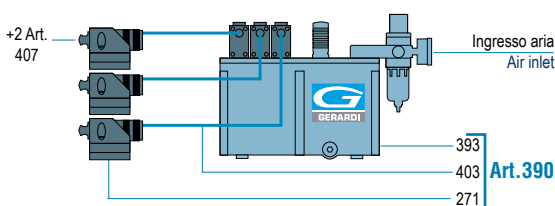

Cod. 4.39.0A103 4.39.0A203 4.39.0A303 4.39.0A403 4.39.0A503 4.39.0A603

--	--	--	--	--	--	--

Art. 390A / 4

N° 4 serraggi indipendenti
N° 4 independent clamping

Art. 390 + n° 3 Art. 407

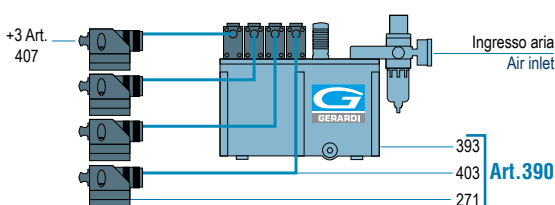

Cod. 4.39.0A104 4.39.0A204 4.39.0A304 4.39.0A404 4.39.0A504 4.39.0A604

--	--	--	--	--	--	--

COMANDO ELETTRICO singolo effetto da CNC / single effect SOLENOID CONTROL by CNC

Tipo (grandezza) morsa / Vise (type) size

1 2 3 4 5 6

Art. 391

N° 1 serraggio
N° 1 clamping

MORSA NON COMPRESA
WISE NOT INCLUDED

Art. 395 + Art. 271 + Art. 403 (m 1,5)

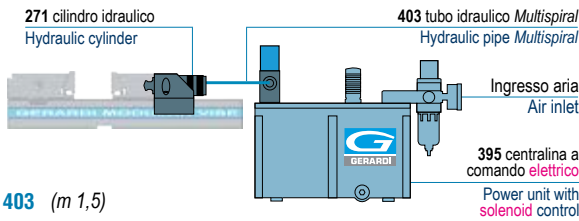

Cod. 4.39.11000 4.39.12000 4.39.13000 4.39.14000 4.39.15000 4.39.16000

Art. 391 / 2

N° 2 serraggi contemporanei
N° 2 simultaneously clamping

Art. 391 + n° 1 Art. 271

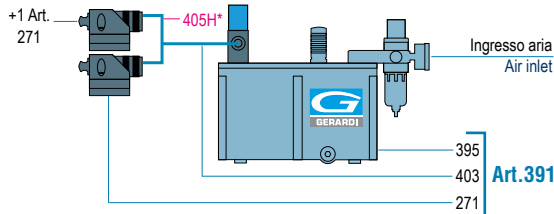

Cod. 4.39.11002 4.39.12002 4.39.13002 4.39.14002 4.39.15002 4.39.16002

* Non incluso (Pag. 4.38) / Not included (Pag. 4.38)

Art. 391 / 3

N° 3 serraggi contemporanei
N° 3 simultaneously clamping

Art. 391 + n° 2 Art. 271

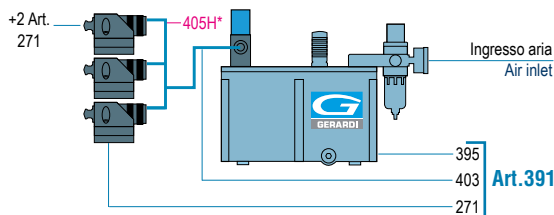

Cod. 4.39.11003 4.39.12003 4.39.13003 4.39.14003 4.39.15003 4.39.16003

* Non incluso (Pag. 4.38) / Not included (Pag. 4.38)

Art. 391 / 4

N° 4 serraggi contemporanei
N° 4 simultaneously clamping

Art. 391 + n° 3 Art. 271

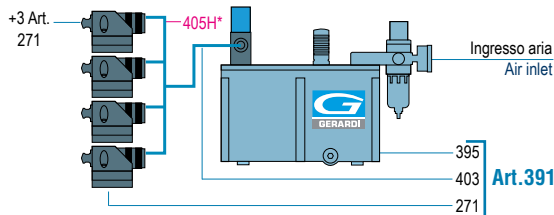

Cod. 4.39.11004 4.39.12004 4.39.13004 4.39.14004 4.39.15004 4.39.16004

* Non incluso (Pag. 4.38) / Not included (Pag. 4.38)

Art. 407A

Gruppo di serraggio indipendente
Independent clamping group

Art. 271 + Art. 398 + Art. 403 (m 1,5)

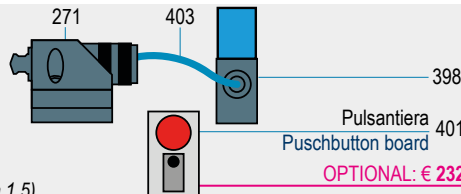

Cod. 4.40.7A100 4.40.7A200 4.40.7A300 4.40.7A400 4.40.7A500 4.40.7A600

OPTIONAL: € 232

Art. 391A / 2

N° 2 serraggi indipendenti
N° 2 independent clamping

Art. 391 + n° 1 Art. 407A

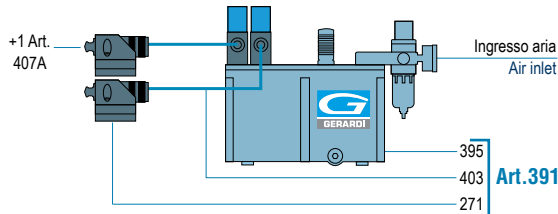

Cod. 4.39.1A102 4.39.1A202 4.39.1A302 4.39.1A402 4.39.1A502 4.39.1A602

Art. 391A / 3

N° 3 serraggi indipendenti
N° 3 independent clamping

Art. 391 + n° 2 Art. 407A

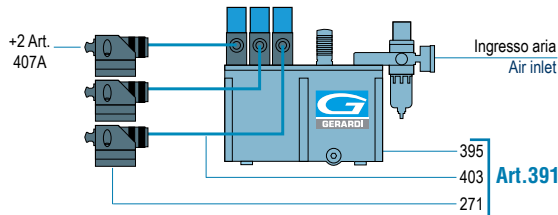

Cod. 4.39.1A103 4.39.1A203 4.39.1A303 4.39.1A403 4.39.1A503 4.39.1A603

Art. 391A / 4

N° 4 serraggi indipendenti
N° 4 independent clamping

Art. 391 + n° 3 Art. 407A

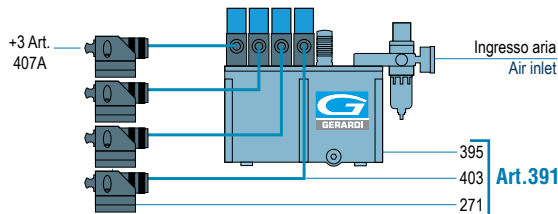

Cod. 4.39.1A104 4.39.1A204 4.39.1A304 4.39.1A404 4.39.1A504 4.39.1A604

COMANDO PNEUMATICO singolo effetto / single effect PNEUMATIC CONTROL

Tipo (grandezza) morsa / Vise (type) size	1	2	3	4	5	6
---	---	---	---	---	---	---

Art. 392

402/90 Valvola pneumatica
Pneumatic valve

403 tubo idraulico Multispiral
Hydraulic pipe Multispiral

271 cilindro idraulico
Hydraulic cylinder

Ingresso aria
Air inlet

394 centralina a comando pneumatico
Power unit with air control valve

N° 1 serraggio
N° 1 clamping

**MORSA NON COMPRESA
VISE NOT INCLUDED**

Art. 394 + 271 + 402 + 403 (m 1,5)

Cod.	4.39.21000	4.39.22000	4.39.23000	4.39.24000	4.39.25000	4.39.26000
------	------------	------------	------------	------------	------------	------------

* Non incluso (Pag. 4.38) / Not included (Pag. 4.38)

Art. 392 / 2

N° 2 serraggi contemporanei
N° 2 simultaneously clamping

+1 Art. 271

-405H*

Ingresso aria
Air inlet

394
402
403
271

Art.392

Cod.	4.39.21002	4.39.22002	4.39.23002	4.39.24002	4.39.25002	4.39.26002
------	------------	------------	------------	------------	------------	------------

* Non incluso (Pag. 4.38) / Not included (Pag. 4.38)

Art. 392 / 3

N° 3 serraggi contemporanei
N° 3 simultaneously clamping

+2 Art. 271

-405H*

Ingresso aria
Air inlet

394
402
403
271

Art.392

Cod.	4.39.21003	4.39.22003	4.39.23003	4.39.24003	4.39.25003	4.39.26003
------	------------	------------	------------	------------	------------	------------

* Non incluso (Pag. 4.38) / Not included (Pag. 4.38)

Art. 392 / 4

N° 4 serraggi contemporanei
N° 4 simultaneously clamping

+3 Art. 271

-405H*

Ingresso aria
Air inlet

394
402
403
271

Art.392

Cod.	4.39.21004	4.39.22004	4.39.23004	4.39.24004	4.39.25004	4.39.26004
------	------------	------------	------------	------------	------------	------------

* Non incluso (Pag. 4.38) / Not included (Pag. 4.38)

Art. 407B

402 Valvola pneumatica
Pneumatic valve

Gruppo di serraggio indipendente
Independent clamping group

396

403

271

Art. 271 + 396 + 402 + 403 (m 1,5)

Cod.	4.40.7B100	4.40.7B200	4.40.7B300	4.40.7B400	4.40.7B500	4.40.7B600
------	------------	------------	------------	------------	------------	------------

Art. 392A / 2

N° 2 serraggi indipendenti
N° 2 independent clamping

+1 Art. 271

+1 Art. 402

Ingresso aria
Air inlet

394
402
403
271

Art.392

Cod.	4.39.2A102	4.39.2A202	4.39.2A302	4.39.2A402	4.39.2A502	4.39.2A602
------	------------	------------	------------	------------	------------	------------

Art. 392A / 3

N° 3 serraggi indipendenti
N° 3 independent clamping

+2 Art. 271

+2 Art. 402

Ingresso aria
Air inlet

394
402
403
271

Art.392

Cod.	4.39.2A103	4.39.2A203	4.39.2A303	4.39.2A403	4.39.2A503	4.39.2A603
------	------------	------------	------------	------------	------------	------------

Art. 392A / 4

N° 4 serraggi indipendenti
N° 4 independent clamping

+3 Art. 271

+3 Art. 402

Ingresso aria
Air inlet

394
402
403
271

Art.392

Cod.	4.39.2A104	4.39.2A204	4.39.2A304	4.39.2A404	4.39.2A504	4.39.2A604
------	------------	------------	------------	------------	------------	------------

4

ACCESSORI e RICAMBI

ACCESSORIES and SPARE PARTS

N.B. Le centraline sono fornite senza olio
N.B The power units are supplied without oil

Art. 393

Centralina a comando **manuale singolo**
 Pressione max 450bar
 Con mantenimento e ripristino automatico della pressione desiderata

Power unit with **single manual** control
 Max pression 450bar
 Automatic retention and reset of desired pressure



Cod. 4.39.34500

Art. 397

Blocco modulare per comando **manuale** aggiuntivo per ogni morsa extra

Modular block for **manual** control for each extra vise

Ingresso aria (Ø 8 - 7bar)
 Air inlet (Ø 8 - 7bar)



Cod. 4.39.70000

Art. 397B

Blocco base per comando **manuale**
 Base block for **manual** control

Ingresso aria (Ø 8 - 7bar)
 Air inlet (Ø 8 - 7bar)



Cod. 4.39.7B000

Art. 394

Centralina a comando **pneumatico remoto**
 (Tramite Art. 402 extra) - Pressione max 450bar
 Con mantenimento e ripristino automatico della pressione desiderata

Power unit with **remote pneumatic** control
 (Through Art. 402 extra) - Max pression 450bar
 Automatic retention and reset of desired pressure



Cod. 4.39.44500

Ingresso aria (Ø 8 - 7bar)
 Air inlet (Ø 8 - 7bar)



Ingresso aria (Ø 8 - 7bar)
 Air inlet (Ø 8 - 7bar)



Art. 396

Blocco modulare per comando **pneumatico** aggiuntivo per ogni morsa extra

Modular block for **pneumatic** control for each extra vise



Cod. 4.39.60000

Art. 396B

Blocco base per comando **pneumatico**
 Base block for **pneumatic** control



Cod. 4.39.6B000

Art. 395

Centralina a comando **elettrico**
 Pressione max 450bar
 Con mantenimento e ripristino automatico della pressione desiderata

Power unit with **electrical** control
 Max pression 450bar
 Automatic retention and reset of desired pressure



Cod. 4.39.54500

Su richiesta:
 12V / 24V / ...V
 On request:
 12V / 24V / ...V

Ingresso aria (Ø 8 - 7bar)
 Air inlet (Ø 8 - 7bar)



Su richiesta:
 12V / 24V / ...V
 On request:
 12V / 24V / ...V

Ingresso aria (Ø 8 - 7bar)
 Air inlet (Ø 8 - 7bar)



Art. 398

Blocco modulare per comando **elettrico** aggiuntivo per ogni morsa extra

Modular block for **electric** control for each extra vise



Cod. 4.39.80000

Art. 398B

Blocco base per comando **pneumatico**
 Base block for **pneumatic** control



Cod. 4.39.8B000

COMANDO MANUALE doppio effetto / double effect MANUAL CONTROL

Tipo (grandezza) morsa / Vise (type) size	1	2	3	4	5	6
---	---	---	---	---	---	---

Art. 390B

N° 1 serraggio
N° 1 clamping

MORSA NON COMPRESA
WISE NOT INCLUDED

Art.393D + Art.271D + Art.403 (m 1,5)

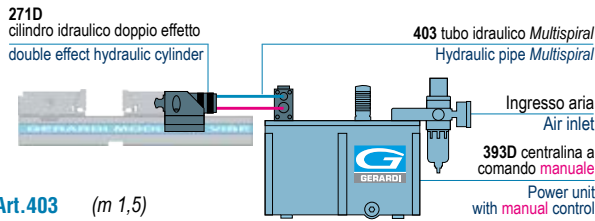

Cod. 4.39.0B100 4.39.0B200 4.39.0B300 4.39.0B400 4.39.0B500 4.39.0B600

--	--	--	--	--	--	--

Art. 390B/2

N° 2 serraggi contemporanei
N° 2 simultaneously clamping

Art. 390B + n° 1 Art.271D

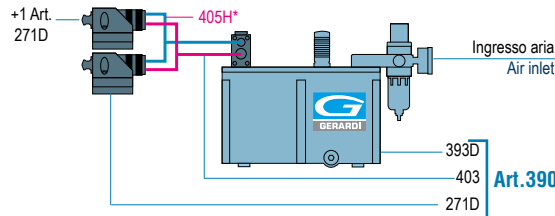

Cod. 4.39.0B102 4.39.0B202 4.39.0B302 4.39.0B402 4.39.0B502 4.39.0B602

--	--	--	--	--	--	--

* Non incluso (Pag. 4.38) / Not included (Pag. 4.38)

Art. 390B/3

N° 3 serraggi contemporanei
N° 3 simultaneously clamping

Art. 390B + n° 2 Art.271D

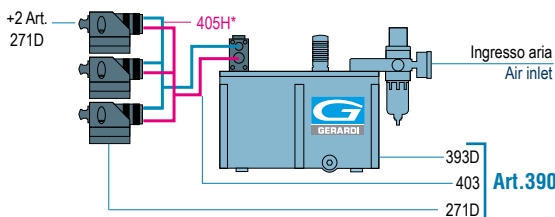

Cod. 4.39.0B103 4.39.0B203 4.39.0B303 4.39.0B403 4.39.0B503 4.39.0B603

--	--	--	--	--	--	--

* Non incluso (Pag. 4.38) / Not included (Pag. 4.38)

Art. 390B/4

N° 4 serraggi contemporanei
N° 4 simultaneously clamping

Art. 390B + n° 3 Art.271D

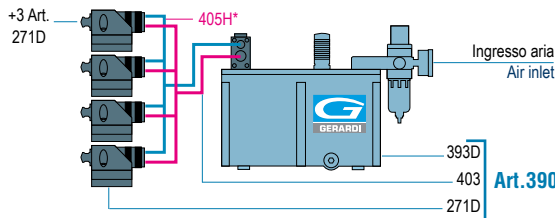

Cod. 4.39.0B104 4.39.0B204 4.39.0B304 4.39.0B404 4.39.0B504 4.39.0B604

--	--	--	--	--	--	--

* Non incluso (Pag. 4.38) / Not included (Pag. 4.38)

Art. 407C

Gruppo di serraggio indipendente
Independent clamping group

Art.271D + Art. 403 + Art. 397D (m 1,5)

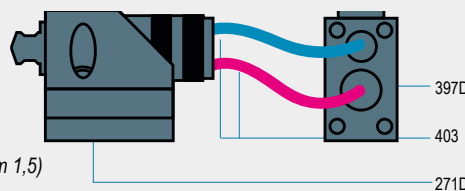

Cod. 4.40.7C100 4.40.7C200 4.40.7C300 4.40.7C400 4.40.7C500 4.40.7C600

--	--	--	--	--	--	--

Art. 390C / 2

N° 2 serraggi indipendenti
N° 2 independent clamping

Art. 390B + n° 1 Art. 407C

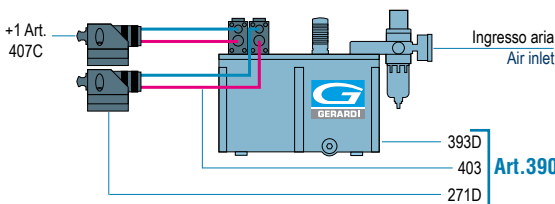

Cod. 4.39.0C102 4.39.0C202 4.39.0C302 4.39.0C402 4.39.0C502 4.39.0C602

--	--	--	--	--	--	--

Art. 390C / 3

N° 3 serraggi indipendenti
N° 3 independent clamping

Art. 390B + n° 2 Art. 407C

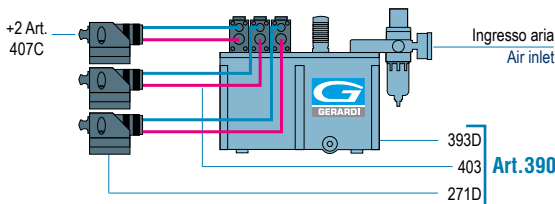

Cod. 4.39.0C103 4.39.0C203 4.39.0C303 4.39.0C403 4.39.0C503 4.39.0C603

--	--	--	--	--	--	--

Art. 390C / 4

N° 4 serraggi indipendenti
N° 4 independent clamping

Art. 390B + n° 3 Art. 407C

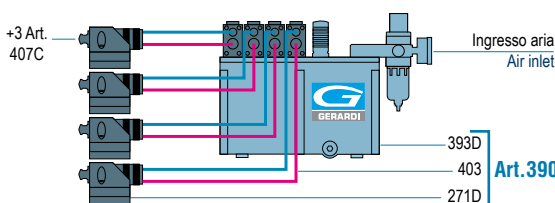

Cod. 4.39.0C104 4.39.0C204 4.39.0C304 4.39.0C404 4.39.0C504 4.39.0C604

--	--	--	--	--	--	--

COMANDO ELETTRICO doppio effetto da CNC / double effect SOLENOID CONTROL by CNC

Tipo (grandezza) morsa / Vise (type) size

1 2 3 4 5 6

Art. 391B

271D
cilindro idraulico doppio effetto
double effect hydraulic cylinder

403 tubo idraulico Multispiral
Hydraulic pipe Multispiral

N° 1 serraggio
N° 1 clamping

MORSA NON COMPRESA
VISE NOT INCLUDED

Art. 395D + Art.271D + Art. 403 (m 1,5)

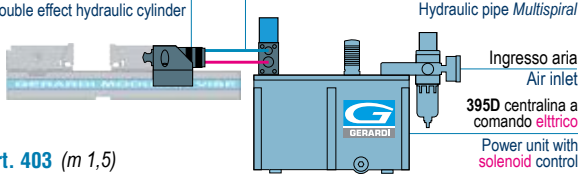

Cod. 4.39.1B100 4.39.1B200 4.39.1B300 4.39.1B400 4.39.1B500 4.39.1B600

--	--	--	--	--	--

Art. 391B / 2

N° 2 serraggi contemporanei
N° 2 simultaneously clamping

Art. 391B + n° 1 Art.271D

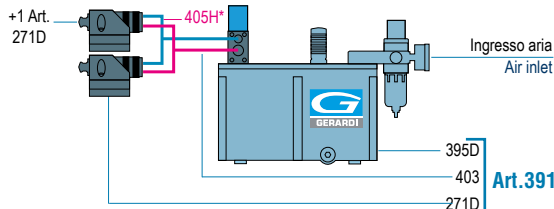

Cod. 4.39.1B102 4.39.1B202 4.39.1B302 4.39.1B402 4.39.1B502 4.39.1B602

--	--	--	--	--	--

Art.391B * Non incluso (Pag. 4.38) / Not included (Pag. 4.38)

Art. 391B / 3

N° 3 serraggi contemporanei
N° 3 simultaneously clamping

Art. 391B + n° 2 Art.271D

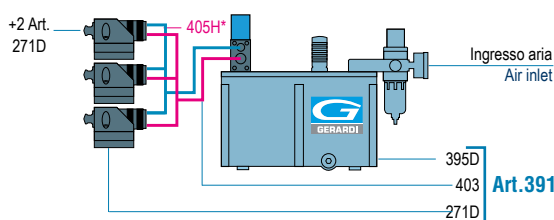

Cod. 4.39.1B103 4.39.1B203 4.39.1B303 4.39.1B403 4.39.1B503 4.39.1B603

--	--	--	--	--	--

Art.391B * Non incluso (Pag. 4.38) / Not included (Pag. 4.38)

Art. 391B / 4

N° 4 serraggi contemporanei
N° 4 simultaneously clamping

Art. 391B + n° 3 Art.271D

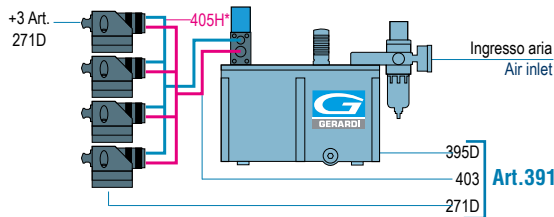

Cod. 4.39.1B104 4.39.1B204 4.39.1B304 4.39.1B404 4.39.1B504 4.39.1B604

--	--	--	--	--	--

Art.391B * Non incluso (Pag. 4.38) / Not included (Pag. 4.38)

Art. 407D

Gruppo di serraggio indipendente
Independent clamping group

Art.271D + Art. 403 + Art.398D (m 1,5)

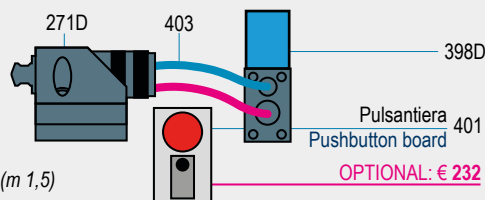

Cod. 4.40.7D100 4.40.7D200 4.40.7D300 4.40.7D400 4.40.7D500 4.40.7D600

--	--	--	--	--	--

Pulsantiera 401
Pushbutton board
OPTIONAL: € 232

Art. 391C / 2

N° 2 serraggi indipendenti
N° 2 independent clamping

Art. 391B + n° 1 Art. 407D

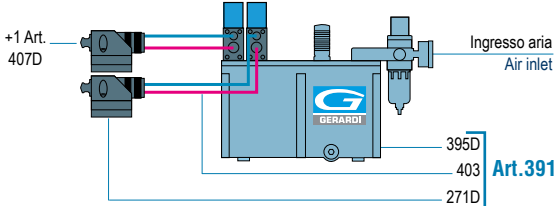

Cod. 4.39.1C102 4.39.1C202 4.39.1C302 4.39.1C402 4.39.1C502 4.39.1C602

--	--	--	--	--	--

Art.391B

Art. 391C / 3

N° 3 serraggi indipendenti
N° 3 independent clamping

Art. 391B + n° 2 Art. 407D

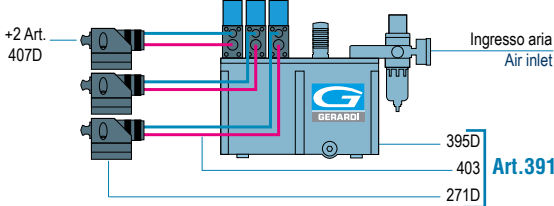

Cod. 4.39.1C103 4.39.1C203 4.39.1C303 4.39.1C403 4.39.1C503 4.39.1C603

--	--	--	--	--	--

Art.391B

Art. 391C / 4

N° 4 serraggi indipendenti
N° 4 independent clamping

Art. 391B + n° 3 Art. 407D

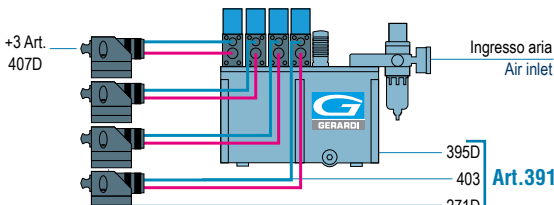

Cod. 4.39.1C104 4.39.1C204 4.39.1C304 4.39.1C404 4.39.1C504 4.39.1C604

--	--	--	--	--	--

Art.391B

COMANDO PNEUMATICO doppio effetto / double effect PNEUMATIC CONTROL

Tipo (grandezza) morsa / Vise (type) size	1	2	3	4	5	6
---	---	---	---	---	---	---

Art. 392B

N° 1 serraggio
N° 1 clamping

**MORSA NON COMPRESA
VISE NOT INCLUDED**

Art. 394D + 271D + 402 + 403 (m 1,5)

402/90 Valvola pneumatica
Pneumatic valve

271D cilindro idraulico doppio effetto
double effect hydraulic cylinder

403 tubo idraulico Multispiral
Hydraulic pipe Multispiral

Ingresso aria
Air inlet

394D centralina a comando pneumatico
Power unit with air control valve

Cod.	4.39.2B100	4.39.2B200	4.39.2B300	4.39.2B400	4.39.2B500	4.39.2B600
------	------------	------------	------------	------------	------------	------------

* Non incluso (Pag. 4.38) / Not included (Pag. 4.38)

Art. 392B / 2

N° 2 serraggi contemporanei
N° 2 simultaneously clamping

Art. 392B + n° 1 Art.271D

+1 Art. 271D

405H*

Ingresso aria
Air inlet

394D
402
403
271D

Art.392B

Cod.	4.39.2B102	4.39.2B202	4.39.2B302	4.39.2B402	4.39.2B502	4.39.2B602
------	------------	------------	------------	------------	------------	------------

* Non incluso (Pag. 4.38) / Not included (Pag. 4.38)

Art. 392B / 3

N° 3 serraggi contemporanei
N° 3 simultaneously clamping

Art. 392B + n° 2 Art.271D

+2 Art. 271D

405H*

Ingresso aria
Air inlet

394D
402
403
271D

Art.392B

Cod.	4.39.2B103	4.39.2B203	4.39.2B303	4.39.2B403	4.39.2B503	4.39.2B603
------	------------	------------	------------	------------	------------	------------

* Non incluso (Pag. 4.38) / Not included (Pag. 4.38)

Art. 392B / 4

N° 4 serraggi contemporanei
N° 4 simultaneously clamping

Art. 392B + n° 3 Art.271D

+3 Art. 271D

405H*

Ingresso aria
Air inlet

394D
402
403
271D

Art.392B

Cod.	4.39.2B104	4.39.2B204	4.39.2B304	4.39.2B404	4.39.2B504	4.39.2B604
------	------------	------------	------------	------------	------------	------------

* Non incluso (Pag. 4.38) / Not included (Pag. 4.38)

Art. 407E

Gruppo di serraggio indipendente
Independent clamping group

Art.271D + 396D + 402 + 403 (m 1,5)

402 Valvola pneumatica
Pneumatic valve

396D

403

271D

Cod.	4.40.7E100	4.40.7E200	4.40.7E300	4.40.7E400	4.40.7E500	4.40.7E600
------	------------	------------	------------	------------	------------	------------

Art. 392C / 2

N° 2 serraggi indipendenti
N° 2 independent clamping

Art. 392B + n° 1 Art. 407B

+1 Art. 407E

Ingresso aria
Air inlet

394D
402
403
271D

Art.392B

Cod.	4.39.2C102	4.39.2C202	4.39.2C302	4.39.2C402	4.39.2C502	4.39.2C602
------	------------	------------	------------	------------	------------	------------

Art. 392C / 3

N° 3 serraggi indipendenti
N° 3 independent clamping

Art. 392B + n° 2 Art. 407B

+1 Art. 402/90

+2 Art. 407E

Ingresso aria
Air inlet

394D
402
403
271D

Art.392B

Cod.	4.39.2C103	4.39.2C203	4.39.2C303	4.39.2C403	4.39.2C503	4.39.2C603
------	------------	------------	------------	------------	------------	------------

Art. 392C / 4

N° 4 serraggi indipendenti
N° 4 independent clamping

Art. 392B + n° 3 Art. 407B

+1 Art. 402/90

+2 Art. 407E

Ingresso aria
Air inlet

394D
402
403
271D

Art.392B

Cod.	4.39.2C104	4.39.2C204	4.39.2C304	4.39.2C404	4.39.2C504	4.39.2C604
------	------------	------------	------------	------------	------------	------------

ACCESSORI e RICAMBI

ACCESSORIES and SPARE PARTS

N.B. Le centraline sono fornite senza olio
N.B. The power units are supplied without oil

Art. 393D

Centralina a comando **manuale doppio**
 Pressione max 450bar
 Con mantenimento e ripristino automatico della pressione desiderata

Power unit with **double manual** control
 Max pression 450bar
 Automatic retention and reset of desired pressure



Cod. 4.39.3D450

Art. 397D

Blocco modulare per comando **manuale** aggiuntivo per ogni morsa extra

Modular block for **manual** control for each extra vise

Ingresso aria (Ø 8 - 7bar)
 Air inlet (Ø 8 - 7bar)



Cod. 4.39.7D000

Art. 397C

Blocco base per comando **manuale**
 Base block for **manual** control

Ingresso aria (Ø 8 - 7bar)
 Air inlet (Ø 8 - 7bar)



Cod. 4.39.7C000

Art. 394D

Centralina a comando **pneumatico remoto doppio** (Tramite Art. 402 extra) - Pressione max 450bar
 Con mantenimento e ripristino automatico della pressione desiderata

Power unit with **double remote pneumatic** control (Through Art. 402 extra) - Max pression 450bar
 Automatic retention and reset of desired pressure



Cod. 4.39.4D450

Ingresso aria (Ø 8 - 7bar)
 Air inlet (Ø 8 - 7bar)



Ingresso aria (Ø 8 - 7bar)
 Air inlet (Ø 8 - 7bar)



Art. 396D

Blocco modulare per comando **pneumatico** aggiuntivo per ogni morsa extra

Modular block for **pneumatic** control for each extra vise



Cod. 4.39.6D000

Art. 396C

Blocco base per comando **pneumatico**
 Base block for **pneumatic** control



Cod. 4.39.6C000

Art. 395D

Centralina a comando **elettrico**
 Pressione max 450bar
 Con mantenimento e ripristino automatico della pressione desiderata

Power unit with **electrical** control
 Max pression 450bar
 Automatic retention and reset of desired pressure



Cod. 4.39.5D450

Su richiesta:
 12V / 24V / ...V
 On request:
 12V / 24V / ...V



Ingresso aria (Ø 8 - 7bar)
 Air inlet (Ø 8 - 7bar)

Cod. 4.39.D8000

Art. 398C

Blocco base per comando **pneumatico**
 Base block for **pneumatic** control



Ingresso aria (Ø 8 - 7bar)
 Air inlet (Ø 8 - 7bar)

Cod. 4.39.8C000

Art. 398D

Blocco modulare per comando **elettrico** aggiuntivo per ogni morsa extra

Modular block for **electric** control for each extra vise

ACCESSORI e RICAMBI ACCESSORIES and SPARE PARTS

Art. 399

Gruppo filtro riduttore più lubrificatore
Compressed air preparation unit



Cod. 4.39.90000

Art. 400

Pedale bistabile
Two positions foot pedal



Cod. 4.40.00000

Art. 401

Pulsantiera per 1 azionamento
Puschbutton board for one control operation



Cod. 4.40.10000

Art. 402

Valvola pneumatica frontale, 2 vie
Frontal pneumatic valve, 2 ways



Cod. 4.40.20000

Art. 402/90

Distributore leva angolare a 90°, 3 vie
90° angular valve, 3 ways



Cod. 9.40.29000

Art. 405H

Per ogni metro extra / For each extra meter:

Coduttura Tubolare in acciaio zincato (m 1,0)
Suitable galvanized steel pipe (m 1,0)



Ø 6

Cod. 4.40.5H000

Art. 403

Per ogni metro extra / For each extra meter:

Tubo idraulico Multispiral 760bar completo di attacco rapido Art. 270A (m 1,5)
Hydraulic pipe *Multispiral* 760 bar complete with rapid connection Art. 270A (m 1,5)



Cod. 4.40.30000

Art. 404

Manometro 400bar
Oil pressure gauge 400bar



Cod. 4.40.40000

ACCESSORI e RICAMBI ACCESSORIES and SPARE PARTS

Art. 270A

Attacco idraulico rapido femmina
Quick hydraulic female connection



Cod. 4.27.0A000

Art. 270B

Innesto idraulico rapido maschio
Quick hydraulic male connection



Cod. 4.27.0B000

Art. ID03

Raccordo idraulico a "L" maschio cilindrico Ø6 - 1/4" Gas
"L" hydraulic male parallel adaptor Ø6 - 1/4" Gas



Cod. 9.ID.03000

Art. ID04

Raccordo idraulico a "T" centrale maschio cilindrico Ø6 - 1/4" Gas
"T" hydraulic male parallel adaptor Ø6 - 1/4" Gas



Cod. 9.ID.04000

Art. ID05

Riduzione idraulica Ø6 - 1/4" Gas
Hydraulic straight male adaptor Ø6 - 1/4" Gas



Cod. 9.ID.05000

Art. 505

Pressostato 400bar
Pressure switch 400bar



Cod. 0.50.50000

ISTRUZIONI INSTRUCIONS

La centralina per serraggi idraulici ed i suoi derivati, nasce per soddisfare tutte le esigenze connesse all'azionamento di cilindri oleodinamici ove sia richiesta bassa portata ed elevate pressioni. La particolare forma costruttiva della centralina permette di ottenere, in ingombri estremamente contenuti, un impianto di elevate prestazioni. L'elemento pompante utilizzato consente, grazie ai particolari criteri costruttivi, di collocare la centralina in ambienti altamente ostili come, per esempio, l'area di lavoro di macchine utensili. L'esclusivo sistema modulare di controllo del flusso idraulico permette di comandare separatamente, con una sola unità, fino a sei utilizzi distinti.

The hydropneumatic power unit for hydraulic clamping devices and its bi-products are designed to meet all needs regarding the powering of hydraulic cylinders where low flow rates and high pressures are required. The special design shape of the power unit is such that a high performance system can be implemented taking up very little space. Thanks to the special design principles, the pump section adopted allows the hydropneumatic power unit to be installed in very hostile environments, such as the work area of machine tools, etc. The unique modular hydraulic flow control system allows controlling up to 6 separate users from just the one power unit.

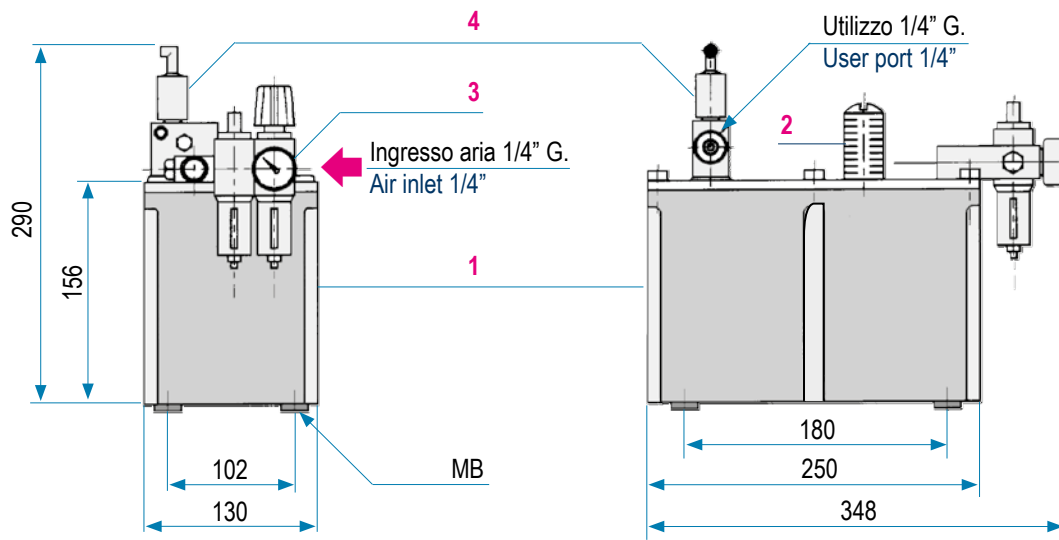

CARATTERISTICHE TECNICHE

SPECIFICATION

Centralina tipo / Power unit type 450 T 2/3/4

Pressione massima aria: Max permissible air pressure:	7 bar
Pressione aria consigliata: Recommended air pressure:	5,5 bar
Tipo di olio raccomandato: idraulico Recommended grade of oil: hydraulic	68 CSt
Portata Deliveries	0,9 L / 1' Litres / min
Capacità serbatoio Tank capacity	3 L
Delta massimo su pilotaggi elettrici: Max delta on electric pilot section:	+ 10% - 5%
Pressione minima su pilotaggio pneumatico: Minimum pressure on pneumatic control:	5 bar
Pressione massima consentita per eventuale pilotaggio elettroidraulico: Max pressure for electrohydraulic control:	150 bar
Numero massimo consigliato di utilizzi: Max permissible air pressure	6

La pompa nella versione base viene fornita completa di:

- serbatoio in teflon 1
- tappo di carica
- silenziatore 2
- attacco di alimentazione aria del tipo ad innesto rapido D8 3
- un blocco di comando oleodinamico 4

The pump in its basic version is supplied complete with:

- teflon tank 1
- fill plug
- silencer 2
- quick acting air connector fitting type D8 3
- hydraulic control block 4

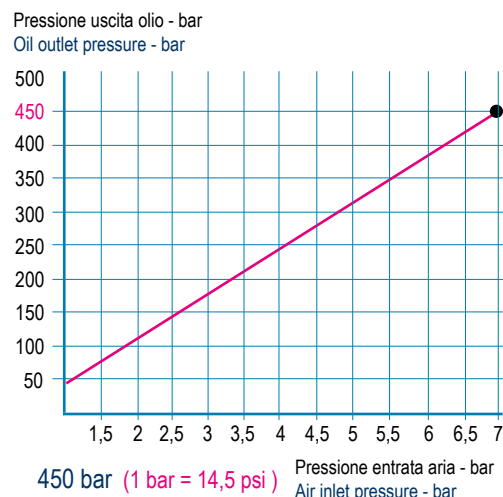

Tipo (grandezza) morsa / Vise (type) size

1
2
3
4
5
6
Art. 266

 Gruppo di serraggio con centralina oleodinamica completa apparato elettrico. **A semplice effetto**
Art. 502 + Art. 271 + Art. 403

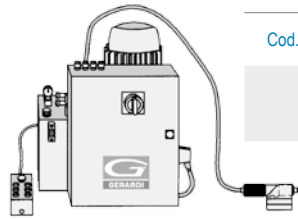
 Hydraulic clamping device complete with motor-driven power unit. **Single acting**

Cod.	2.26.61000	2.26.62000	2.26.63000	2.26.64000	2.26.65000	2.26.66000
------	------------	------------	------------	------------	------------	------------

--	--	--	--	--	--	--

Art. 267

 Gruppo di serraggio con centralina oleodinamica completa di apparato elettrico. **A doppio effetto.**
Art. 503 + Art. 271 + Art. 403

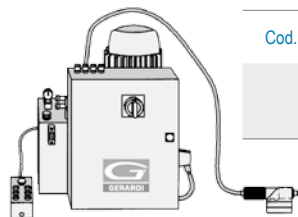
 Hydraulic clamping device complete with motor-driven power unit. **Double acting**

Cod.	2.26.71000	2.26.72000	2.26.73000	2.26.74000	2.26.75000	2.26.76000
------	------------	------------	------------	------------	------------	------------

--	--	--	--	--	--	--

Art. 502

 Centralina oleodinamica a **semplice effetto**

 (Unità elettroidraulica senza gruppo di bloccaggio **Art. 271**)

 Electric motor-driven hydraulic power unit **single acting**
 (Without blocking device **Art. 271**)

Cod.	2.50.20000
------	------------

--	--

Art. 503

 Centralina oleodinamica a **doppio effetto**

 (Unità elettroidraulica senza gruppo di bloccaggio **Art. 271**)

 Electric motor-driven hydraulic power unit **double acting**
 (Without blocking device **Art. 271**)

Cod.	2.50.30000
------	------------

--	--

La lunghezza standard dei collegamenti elettrici e idraulici, è di 1600 mm.

Extra lunghezze saranno quotate separatamente.

Per bloccaggi multipli chiedere la quotazione

Standard lenght for electrical wire and high pressure hose is 1600 mm.

Extra lenght will be quoted separatly.

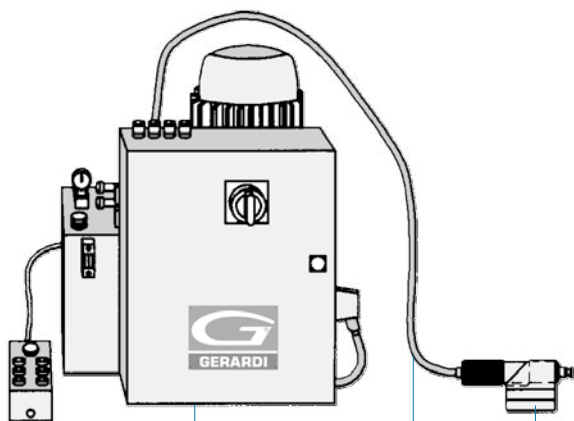
For multiple clamping, ask for specific quotation
Art. 266

Art. 502

Art. 403

Art. 271

GRUPPI DI BLOCCAGGIO CON CENTRALINA OLEODINAMICA
HYDRAULIC BLOCKING DEVICE WITH MOTOR DRIVEN POWER UNIT

Tipo e caratteristiche Type and characteristics		Art. 266 - Art. 502	Art. 267 - Art. 503
		A effetto semplice Single-acting	A doppio effetto Double-acting
Pressione max d'esercizio Max opening pressure	bar	600	
	psi	8.700	
Portata Delivery	l / min	40	
Potenza motore Motor power	KW	5,5	
Massima capacità olio Max oil capacity	l / min	200	
Regolazione pressione Pressure adjustment		Pressostato	By pressure switch
Peso Weight	kg	-	-

SERRAGGIO IDRAULICO HYDRAULIC CLAMPING

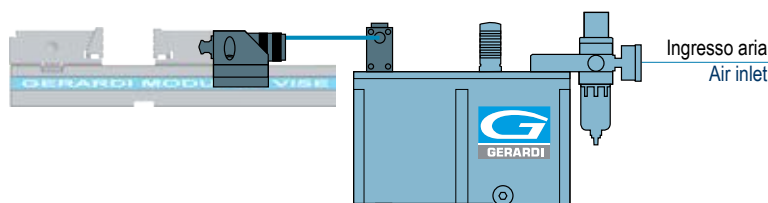

TRAMITE GRUPPI DI SERRAGGIO PNEUMATICI E OLEODINAMICI

I diagrammi seguenti consentono di determinare le forze di serraggio ottenibili con le morse di varia grandezza (da 1 a 6), provvisti di vari dispositivi di bloccaggio idraulico, in funzione della pressione dei fluidi (aria e olio)

THROUGH PNEUMO-HYDRAULIC AND HYDRAULIC CLAMPING DEVICES

The following diagrams give the clamping force that can be obtained with each vise type (size 1 to 6) when equipped with hydraulic blocking devices, as a function of the fluid pressure (air or oil)

4

MORSE MODULARI TIPO 1 MODULAR VISES TYPE 1

Cilindro idraulico Art. 285 - 568 - 569
Ø interno 20 mm - Superficie efficace 3 cm²
Hydraulic cylinder Art. 285 - 568 - 569
Cylinder I.D. 20 mm - Effective area 3 cm²

Con moltiplicatore di pressione Art. 393 (Tipo 450)
With pressure multiplier Art.393 (Type 450)

Pressione entrata aria bar / Air inlet pressure bar

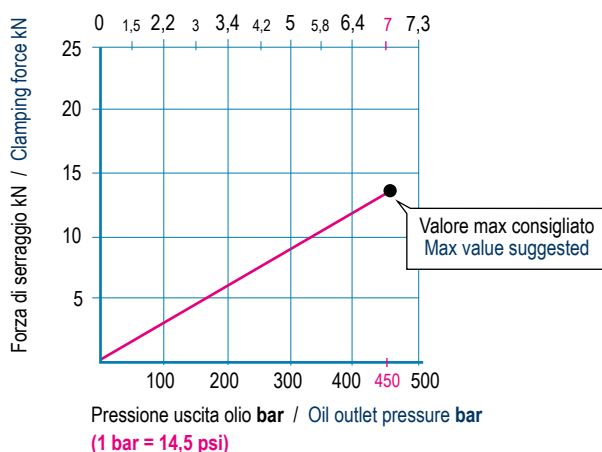

Con centralina elettroidraulica Art. 266 - 267 - 502 - 503
With motor driven hydraulic power unit Art. 266 - 267 - 502 - 503

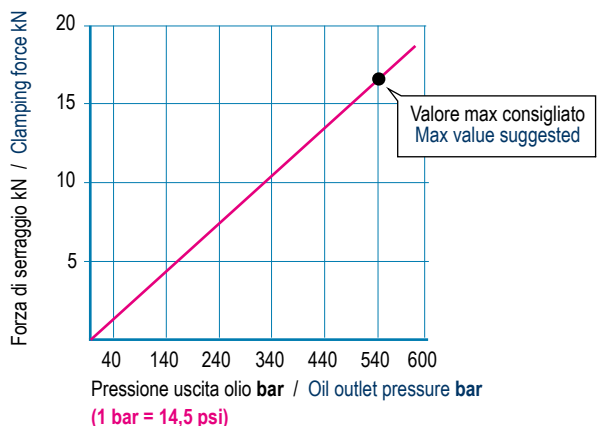

NB: Alcuni fattori, come la lubrificazione, lo staffaggio, gli attriti ed altro, possono modificare i valori indicati fino a ± 10%.
Per un corretto utilizzo non superare i valori indicati nel grafico

MORSE MODULARI TIPO 2-3-4 MODULAR VISES TYPE 2-3-4

Cilindro idraulico Art. 285 - 568 - 569
Ø interno 30 mm - Superficie efficace 7 cm²
Hydraulic cylinder Art. 285 - 568 - 569
Cylinder I.D. 30 mm - Effective area 7 cm²

Con moltiplicatore di pressione Art. 393 (Tipo 450)
With pressure multiplier Art.393 (Type 450)

Pressione entrata aria bar / Air inlet pressure bar

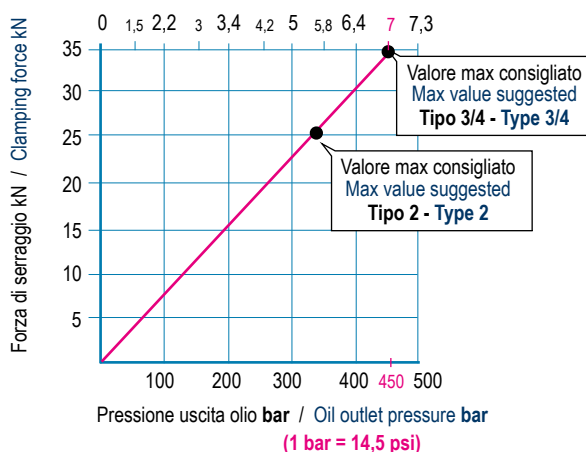

Con centralina elettroidraulica Art. 266 - 267 - 502 - 503
With motor driven hydraulic power unit Art. 266 - 267 - 502 - 503

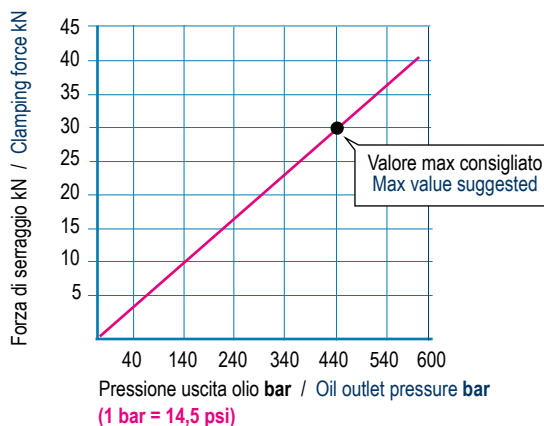

Some factor as lubrication, clamping on the machine table, frictions and more can modify above values within a ± 10% range.
For optimum operation do not exceed chart values.

SERRAGGIO IDRAULICO HYDRAULIC CLAMPING

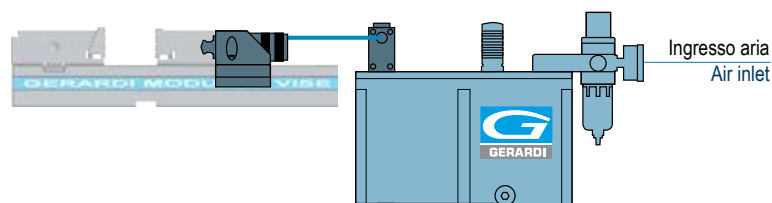

TRAMITE GRUPPI DI SERRAGGIO PNEUMATICI E OLEODINAMICI

I diagrammi seguenti consentono di determinare le forze di serraggio ottenibili con le morse di varia grandezza (da 1 a 6), provvisti di vari dispositivi di bloccaggio idraulici, in funzione della pressione dei fluidi (aria e olio)

THROUGH PNEUMO-HYDRAULIC AND HYDRAULIC CLAMPING DEVICES

The following diagrams give the clamping force that can be obtained with each vise type (size 1 to 6) when equipped with hydraulic blocking devices, as a function of the fluid pressure (air or oil)

MORSE MODULARI TIPO 5 MODULAR VISES TYPE 5

Cilindro idraulico Art. 285 - 568 - 569
Ø interno 40 mm - Superficie efficace 12,5 cm²
Hydraulic cylinder Art. 285 - 568 - 569
Cylinder I.D. 40 mm - Effective area 12.5 cm²

Con moltiplicatore di pressione Art. 393 (Tipo 450)
With pressure multiplier Art.393 (Type 450)

Pressione entrata aria bar / Air inlet pressure bar

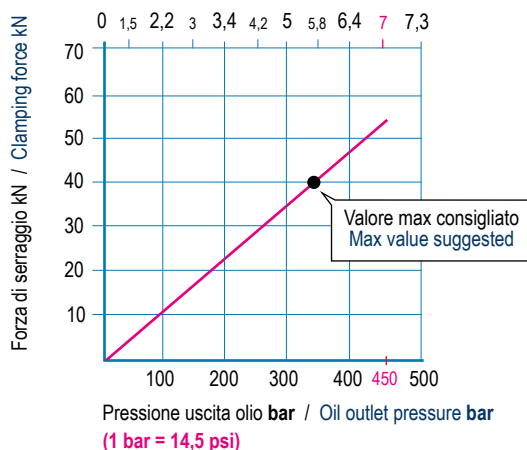

MORSE MODULARI TIPO 6 MODULAR VISES TYPE 6

Cilindro idraulico Art. 285 - 568 - 569
Ø interno 50 mm - Superficie efficace 19,6 cm²
Hydraulic cylinder Art. 285 - 568 - 569
Cylinder I.D. 50 mm - Effective area 19.6 cm²

Con moltiplicatore di pressione Art. 393 (Tipo 450)
With pressure multiplier Art.393 (Type 450)

Pressione entrata aria bar / Air inlet pressure bar

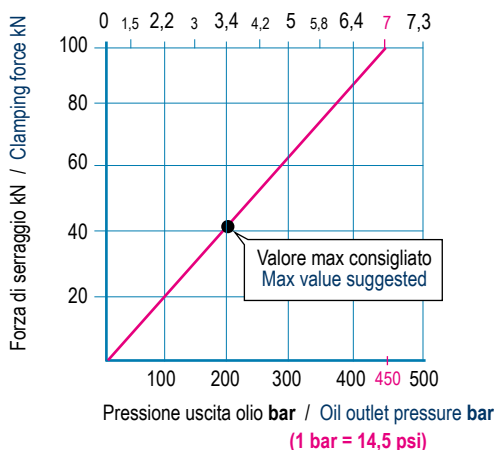

Con centralina elettroidraulica Art. 266 - 267 - 502 - 503
With motor driven hydraulic power unit Art. 266 - 267 - 502 - 503

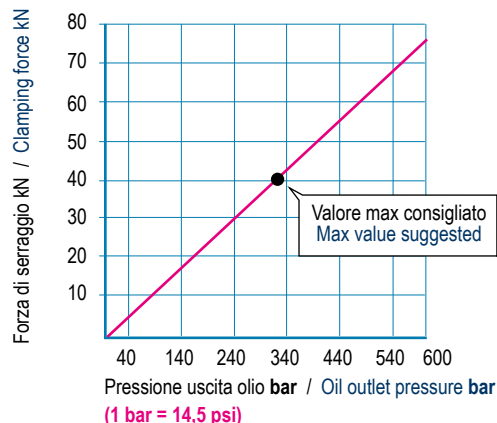

Con centralina elettroidraulica Art. 266 - 267 - 502 - 503
With motor driven hydraulic power unit Art. 266 - 267 - 502 - 503

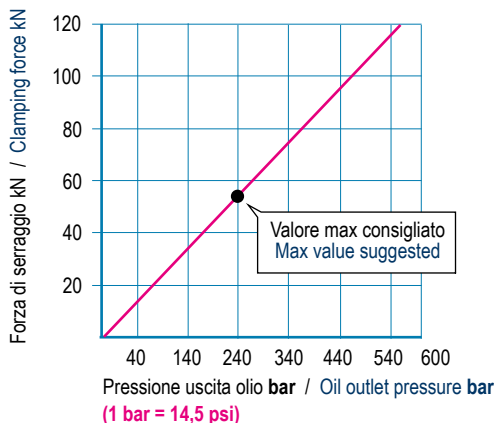

NB: Alcuni fattori, come la lubrificazione, lo staffaggio, gli attriti ed altro, possono modificare i valori indicati fino a ± 10%.
Per un corretto utilizzo non superare i valori indicati nel grafico

Some factor as lubrication, clamping on the machine table, frictions and more can modify above values within a ± 10% range.
For optimum operation do not exceed chart values.

CELLE DI CARICO / LOADING CELLS

Tipo (grandezza) morsa / Vise (type) size

1 2 3 4 5 6

Art. 272

Cella di carico **completa** per controllo forza di bloccaggio delle morse
Complete loading cells to check vise clamping force



kN	60	-	-
Cod.	4.27.26000	-	-
Ø A	90	-	-
B	37	-	-
C	4	-	-
D	30	-	-
E	c.a. 150	-	-

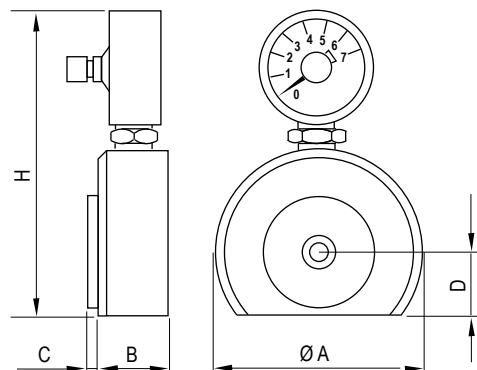

Art. 272A

Indicatore di forza kN
Force indicator kN



Cod.	4.27.2A600	-	-
------	------------	---	---

LA FORZA DELLA QUALITÀ ! THE STRENGTH OF QUALITY !

Art. 394

Pag. 4.41

Centralina a comando **pneumatico remoto**
(Tramite Art. 402 extra) - Pressione max 450bar
Con mantenimento e ripristino automatico della pressione desiderata

Power unit with **remote pneumatic** control
(Through Art. 402 extra) - Max pression 450bar
Automatic retention and reset of desired pressure

Art. 395

Pag. 4.41

Centralina a comando **elettrico**
Pressione max 450bar
Con mantenimento e ripristino automatico della pressione desiderata

Power unit with **electrical** control
Max pression 450bar
Automatic retention and reset of desired pressure

