

PRODUKTÜBERSICHT

PRODUCT OVERVIEW



Drehen
turning

Fräsen
milling

Drehen turning

Inhalt
content

	<p>ULTRAMINI</p>	<p>Bohrungsbearbeitung ab Ø 0.2 mm</p> <p>Grooving, boring and profiling starting at Ø 0.2 mm</p>	<p>1</p>	
	<p>MINICUT</p>	<p>Bohrungsbearbeitung ab Ø 7.8 mm</p> <p>Grooving, boring and profiling starting at Ø 7.8 mm</p>	<p>118</p>	
	<p>SWISSLINE</p>	<p>Miniaturaußenbearbeitung, zweischneidig</p> <p>miniature external machining, two-cutting edges</p>	<p>182</p>	
	<p>STECHDREH- WERKZEUGE</p>	<p>SYSTEM DED: Einstechen dreischneidig SYSTEM ZTP: Einstechen zweischneidig</p> <p>system DED: grooving with three-cutting edges system ZTP: grooving with two-cutting edges</p>	<p>230</p>	
	<p>NUTSTOSSEN</p>	<p>Herstellung von Längsnuten Breite 2-20 mm und Innensechskant</p> <p>Broaching keyways in the range of 2-20 mm and hexagon socket</p>	<p>278</p>	

Fräsen milling

Inhalt
content

	<p>MIKROMILL</p>	<p>Nut- und Formzirkularfräsen drei- und vierschneidig, ab Ø 1.3 mm</p> <p>Groove milling by circular interpolation with three and four cutting edges, starting at Ø 1.3 mm</p>	<p>312</p>	
	<p>MINIMILL</p>	<p>Nut- und Formzirkularfräsen drei- und sechsschneidig, ab Ø 10 mm</p> <p>Groove milling by circular interpolation with three and six cutting edges, starting at Ø 10 mm</p>	<p>334</p>	
	<p>SYSTEM 500</p>	<p>Nut- und Formfräsen Nut- und Trennfräsen</p> <p>Groove milling by circular interpolation groove milling and slotting cutter</p>	<p>430</p>	
	<p>rotaline</p>	<p>Ausspindeln ab Ø 0.4 mm</p> <p>Precision boring starting at Ø 0.4 mm</p>	<p>460</p>	

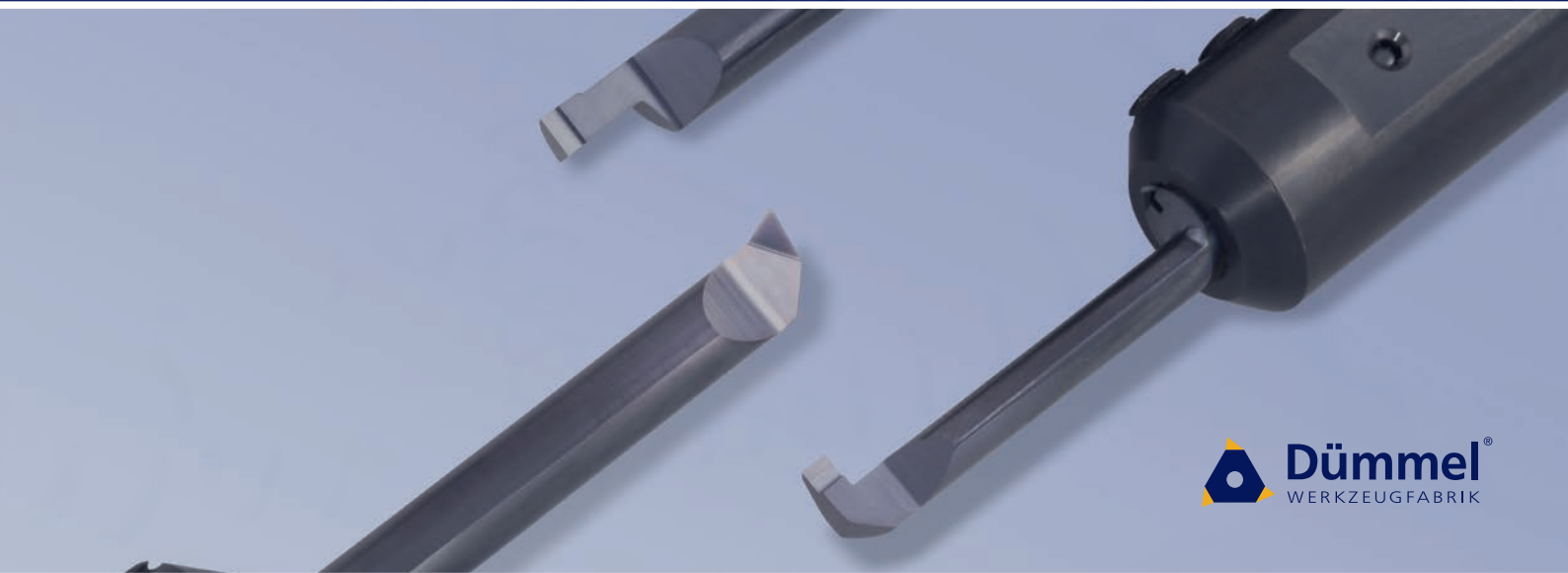

ULTRAMINI



Bohrungsbearbeitung ab \varnothing 0.2 mm

Grooving, boring and profiling
starting at \varnothing 0.2 mm

ULTRAMINI

Bohrungsbearbeitung
ab Ø 0.2 mm

grooving, boring and profiling
starting at Ø 0.2 mm

Übersicht

summary

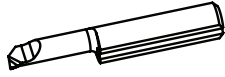

Allgemeine Beschreibung

general instructions

... 8



**Klemmhalter
Rundschaft**

**toolholder
straight shank**

**Maße
dimensions**

**Seite
page**

Typ 645	Klemmhalter	toolholder	Ø 12 - 28 D min. 0.2 - 5.0	... 11
Typ 645.PT	Klemmhalter, Premiumline mit verbesserter Kühlung	toolholder, Premiumline with improved cooling	Ø 12 - 28 D min. 0.2 - 5.0	... 12
Typ 676	Klemmhalter	toolholder	Ø 16 - 28 D min. 6.0 - 7.0	... 13
Typ 676.PT	Klemmhalter, Premiumline mit verbesserter Kühlung	toolholder, Premiumline with improved cooling	Ø 15.87 - 28 D min. 6.0 - 7.0	... 14
Typ 687 / 681	Klemmhalter	toolholder	Ø 16 - 20 / Ø 20 D min. 6.8 - 7.8 / D min. 7.8 - 10.5	... 15
Typ 687.PT	Klemmhalter, Premiumline mit verbesserter Kühlung	toolholder, Premiumline with improved cooling	Ø 16 - 20 D min. 6.8 - 7.8	... 16
Typ 640 / 650 / 660 / 670 / 680	Klemmhalter	toolholder	Ø 12 / Ø 12.7 D min. 0.2 - 7.8	... 17
Typ 645.K	Klemmhalter, ideal für Typ 520 und mit zentraler Kühlbohrung	toolholder, perfect for type 520 and with central cooling bore	Ø 12 - 20 D min. 0.2 - 5.0	... 18
Typ 676.K	Klemmhalter, ideal für Typ 520 und mit zentraler Kühlbohrung	toolholder, perfect for type 520 and with central cooling bore	Ø 16 - 20 D min. 6.0 - 7.0	... 19
TYP UMST	Klemmhalter, mit Hochdruckanschluss für Langdreher	toolholder, with high-pressure connection for Swiss type Machines	Ø 16 - 28 D min. 0.2 - 7.8	... 20
Typ UM600H	High-Performance-Klemmhalter, mit Kühlmittelanschluss	high-performance toolholder, with coolant connection	Ø 12 - 28 D min. 0.2 - 7.0	... 22

ULTRAMINI

Bohrungsbearbeitung
ab \varnothing 0.2 mm

grooving, boring and profiling
starting at \varnothing 0.2 mm

Übersicht

summary

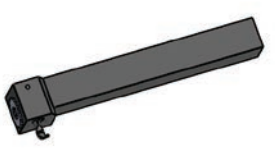
	Klemmhalter Quadratschaft und Rechteckschaft	toolholder square shank and rectangle shank	Maße dimensions	Seite page
Typ UM	Klemmhalter, Quadratschaft	toolholder, square shank	ab / starting at 10 x 10 mm D min. 0.2 - 7.0	... 25
Typ .IK.UHCM	Klemmhalter, Quadratschaft, mit Innenkühlung	toolholder, square shank, with internal cooling	ab / starting at 12 x 12 mm D min. 0.2 - 7.0	... 26
Typ .UM.18 / .UM.28	Klemmhalter, Quadratschaft, mit Innenkühlung	toolholder, square shank, with internal cooling	10 x 10 mm D min. 0.2 - 7.0	... 27
Typ .UM.18 / .UM.28	Klemmhalter, Quadratschaft, mit Innenkühlung	toolholder, square shank, with internal cooling	12 x 12 mm D min. 0.2 - 7.0	... 28
Typ TD0710	Klemmhalter, Rechteckschaft für Tornos DECO 7/10	toolholder, rectangle shank for Tornos DECO 7/10	25 x 26 mm D min. 0.2 - 7.0	... 29

	Höhenverstellbarer Klemmhalter und Reduzierhülse für Rückseitenbearbeitung auf Langdrehautomaten	height adjustable toolholder and reduction bush for rear end machining on Swiss type lathes	Maße dimensions	Seite page
Typ UMHV	Höhenverstellbarer Klemmhalter und Reduzierhülse	height adjustable toolholder and reduction bush	D min. ab 0.2 / starting at 0.2	... 30

ULTRAMINI

Bohrungsbearbeitung
ab Ø 0.2 mm

grooving, boring and profiling
starting at Ø 0.2 mm

Übersicht

summary

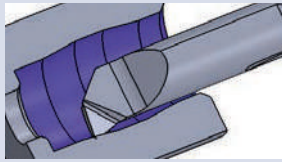

Schneideinsätze
Ausdrehen und Kopieren

inserts
boring and profiling

Maße
dimensions

Seite
page

Typ 050	Ausdrehen und Kopieren	boring and profiling	D min. 0.2 - 9.8	... 32
Superfinish Typ F050	Superfinish Ausdrehen für perfekte Oberflächen	Superfinish boring for perfect surface quality	D min. 4.0 - 6.8	... 37
Typ 050.20	Ausdrehen und Kopieren mit Geometrie 20° / 20°	boring and profiling with geometry 20° / 20°	D min. 2.0 - 5.0	... 38
Typ 053	Ausdrehen und Kopieren mit Eckenradius 0.03 mm	boring and profiling with corner radius 0.03 mm	D min. 2.8 - 4.0	... 39
Typ 055	Ausdrehen und Kopieren mit Eckenradius 0.05 mm	boring and profiling with corner radius 0.05 mm	D min. 2.0 - 6.0	... 40
Typ 050....B	Ausdrehen und Kopieren mit innerer Kühlmittelzufuhr	boring and profiling with through coolant	D min. 6.0 - 6.8	... 42
Typ 050....C	Ausdrehen und Kopieren mit Spantreppe für bessere Spankontrolle	boring and profiling with chipbreaker for better chipcontrol	D min. 2.0 - 6.8	... 43
Mediline Typ M050	Ausdrehen und Kopieren mit innerer Kühlmittelzufuhr und modifizierter Geometrie	boring and profiling with through coolant and modified profile	D min. 0.5 - 4.0	... 45
Xtraline Typ X050	Ausdrehen und Kopieren mit innerer Kühlmittelzufuhr, Spantreppe, extra stabile Ausführung	boring and profiling with through coolant, chipbreaker and extra solid construction	D min. 1.0 - 7.0	... 47
Hardline Typ 050	Ausdrehen und Kopieren, Hartbearbeitung bis 66 HRC	boring and profiling, hard machining up to 66 HRC	D min. 2.0 - 6.8	... 52
Typ 050..../CBN	Ausdrehen und Kopieren, für Hartbearbeitung	boring and profiling, for hard machining	D min. 2.8 - 6.8	... 54
Typ 047	Ausdrehen und Kopieren mit Geometrie 47° / 8°	boring and profiling with geometry 47° / 8°	D min. 2.0 - 6.0	... 55
Typ 090	Ausdrehen und Kopieren mit Geometrie 20° / 90°	boring and profiling with geometry 20° / 90°	D min. 2.8 - 5.0	... 56

ULTRAMINI

Bohrungsbearbeitung
ab \varnothing 0.2 mm

grooving, boring and profiling
starting at \varnothing 0.2 mm

Übersicht

summary

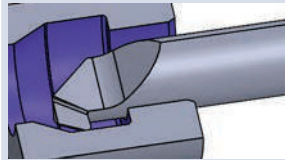

**Schneideinsätze
Rückwärtsdrehen**

**inserts
backboring**

**Maße
dimensions**

**Seite
page**

Typ 080

Rückwärtsdrehen

backboring

D min. 3.0 - 7.0

... 57

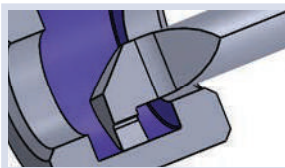

**Schneideinsätze
Stechdrehen**

**inserts
grooving**

**Maße
dimensions**

**Seite
page**

Typ 001 / 0015

Stechdrehen

grooving

D min. 1.0 / 1.5
t max. 0.2 / 0.4

... 59

Typ 002

Stechdrehen

grooving

D min. 2.0
t max. 0.4

... 60

Typ 003

Stechdrehen

grooving

D min. 3.0
t max. 0.6

... 61

Typ 004

Stechdrehen

grooving

D min. 4.0
t max. 0.8

... 62

Typ 004M

Stechdrehen
mit Eckenradius

grooving
with corner radius

D min. 4
t max. 0.8

... 63

Typ 005

Stechdrehen

grooving

D min. 5
t max. 1.0

... 64

Typ 005M

Stechdrehen
mit Eckenradius

grooving
with corner radius

D min. 5
t max. 1.0

... 66

Typ 006

Stechdrehen

grooving

D min. 6
t max. 1.8

... 68

Typ 006M

Stechdrehen
mit Eckenradius

grooving
with corner radius

D min. 6
t max. 1.8

... 70

Typ 007

Stechdrehen

grooving

D min. 6.8
t max. 2.5

... 72

Typ 007M

Stechdrehen
mit Eckenradius

grooving
with corner radius

D min. 6.8
t max. 2.5

... 74

Typ 008M

Stechdrehen
mit Eckenradius

grooving
with corner radius

D min. 7.8
t max. 3.0

... 76

↳ ...

ULTRAMINI

Bohrungsbearbeitung
ab Ø 0.2 mm

grooving, boring and profiling
starting at Ø 0.2 mm

Übersicht

summary



Schneideinsätze Stechdrehen

inserts grooving

Maße dimensions

Seite page

... ↴

Typ 10M	Stechdrehen mit Eckenradius und innerer Kühlmittelzufuhr	grooving with corner radius and through coolant	D min. 10.5 t max. 4.0	... 77
Typ 004 / 005 / 006 / 007	Stechdrehen und Kopieren mit Vollradius	grooving and profiling with full radius	D min. 4.0 R 0.5 - 1.0	... 78
Typ 060	Ausdrehen und Fasen	boring and chamfering	D min. 3.0 - 6.8	... 79
Typ 070	Vorstechen und Fasen	pregrooving and chamfering	D min. 4.0 - 6.0	... 80

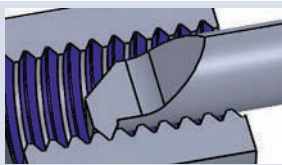

Schneideinsätze Gewindedrehen, innen

inserts threading, internal

Maße dimensions

Seite page

Typ Gewindedrehen	metrisches ISO-Gewinde, Teilprofil, innen	type threading, metric ISO-thread, partial profile, internal	D min. 1.56 - 7.0 P = 0.4 - 1.75	... 82
Typ Gewindedrehen	metrisches ISO-Gewinde, Vollprofil, innen	type threading, metric ISO-thread, full profile, internal	D min. 4.0 - 7.0 P = 0.5 - 1.5	... 84
Typ Gewindedrehen	Whitworth-Gewinde, Teilprofil, innen	type threading, Whitworth thread, partial profile, internal	D min. 4.8 - 7.0	... 85
Typ Gewindedrehen	Whitworth-Gewinde, Vollprofil, innen	type threading, Whitworth thread, full profile, internal	D min. 6.0	... 86
Typ Gewindedrehen	NPT-Gewinde, Teilprofil, innen	type threading, NPT thread, partial profile, internal	D min. 6.0	... 87
Typ Gewindedrehen	Trapezgewinde, Teilprofil, innen	type threading, trapezoidal thread, partial profile, internal	D min. 7.0 P = 2.0 - 3.0	... 88

ULTRAMINI

Bohrungsbearbeitung
ab \varnothing 0.2 mm

grooving, boring and profiling
starting at \varnothing 0.2 mm

Übersicht

summary

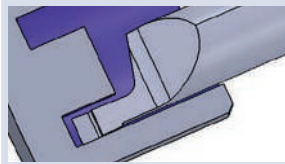

Schneideinsätze Axialstechen

inserts face grooving

Maße dimensions

Seite page

Typ	Schneideinsätze Axialstechen	inserts face grooving	Maße dimensions	Seite page
Typ 510M	Axialstechen mit Eckenradius	face grooving with corner radius	D min. 5.0 t max. 4.0	... 90
Typ 610	Axialstechen	face grooving	D min. 6.0 t max. 3.5	... 91
Typ 610M	Axialstechen mit Eckenradius	face grooving with corner radius	D min. 6.0 t max. 6.0	... 92
Typ 610	Axialstechen mit Vollradius	face grooving with full radius	D min. 6.0 t max. 6.0	... 93
Typ 620	Axialstechen am Zapfen vorbei	face grooving in pivots	D min. 6.0 t max. 6.0	... 94
Typ 620M	Axialstechen am Zapfen vorbei, mit Eckenradius	face grooving in pivots, with corner radius	D min. 6.0 t max. 6.0	... 95
Typ 010	Axialstechen	face grooving	D min. 6.0 t max. 3.5	... 96
Typ 010M	Axialstechen mit Eckenradius	face grooving with corner radius	D min. 8.0 t max. 6.0	... 98
Typ 010	Axialstechen mit Vollradius	face grooving with full radius	D min. 8.0 t max. 6.0	... 100
Typ 015	Axialstechen	face grooving	D min. 8.0 t max. 3.0	... 101
Typ 015M	Axialstechen mit Eckenradius	face grooving with corner radius	D min. 8.0 t max. 3.0	... 102
Typ 012 / 016	Axialstechen mit Eckenradius und doppeltem Kühlkanal	face grooving with corner radius and double internal cooling	D min. 12.0 t max. 2.0	... 103
Typ 020	Axialstechen mit Eckenradius und doppeltem Kühlkanal	face grooving with corner radius and double internal cooling	D min. 20.0 t max. 4.0	... 104
Typ 520	Fasen	chamfering	D min. 1.0 t max. 4.0	... 105



ULTRAMINI

Bohrungsbearbeitung
ab Ø 0.2 mm

grooving, boring and profiling
starting at Ø 0.2 mm

Übersicht

summary



Sets Ultramini

Halter und Schneiden (Rechte Ausführung)

sets Ultramini

toolholder and inserts (righthand version)

Maße dimensions

Seite page

SET.1

- Ausdrehen und Kopieren
- Ausdrehen und Fasen
- Stechdrehen

- boring and profiling
- boring and chamfering
- grooving

... 106

SET.2

- Stechdrehen

- grooving

... 106

SET.3

- Ausdrehen und Kopieren

- boring and profiling

... 107

SET.6R

- Axialstechen

- face grooving

... 107

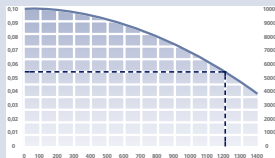

Technische Hinweise

Technical Instructions

Seite page

Grundsätzliche Informationen zum
Werkzeugprogramm Ultramini

Basic informations about the tool
program Ultramini

... 108

Allgemeine Informationen zum
Gewindeschneiden

General informations about threading

... 109

Hartmetallsorten und Beschichtungen

carbide grades and coatings

... 111

Schnittdaten

cutting data

... 113

ULTRAMINI

Bohrungsbearbeitung
ab \varnothing 0.2 mm

grooving, boring and profiling
starting at \varnothing 0.2 mm

Allgemeine Beschreibung

general instruction

Ultramini:

Das überlegene System in der Mini-Bohrungsbearbeitung mit über 1000 Schneideinsätzen!

Ultramini:

The superior system in the world of miniature machining with over 1000 different inserts!

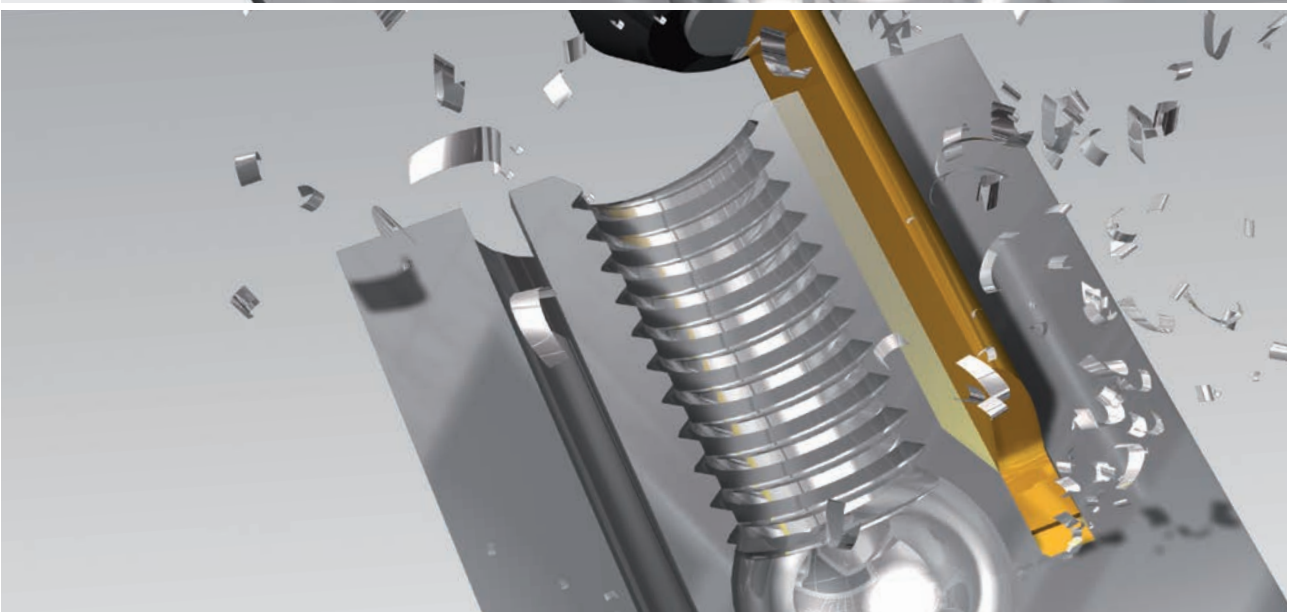

ULTRAMINI

Bohrungsbearbeitung
ab \varnothing 0.2 mm

grooving, boring and profiling
starting at \varnothing 0.2 mm

Allgemeine Beschreibung

Superfinish, Mediline, Xtraline und Hardline

general instruction
Superfinish, Mediline, Xtraline and Hardline



Superfinish Typ F050

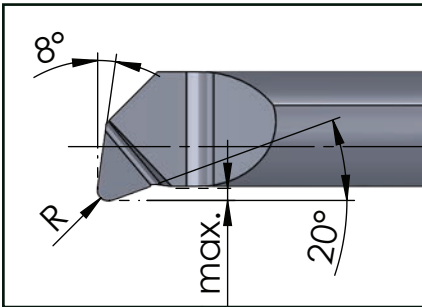

- Großer Eckenradius für hohe Oberflächenqualität
- Sonderhartmetall für einen stabilen und schwingungsarmen Aufbau
- Optimierte Beschichtung für eine geringe Rauhtiefe in der Bohrung
- Bei Einsatz im PT-Halter verbesserte Kühlung
- Big corner radius for high surface quality
- Premium carbide for a strong and low-vibration construction
- Optimized coating causes extremely low surface roughness in the bore
- Better cooling by using PT-toolholder

Mediline Typ M050

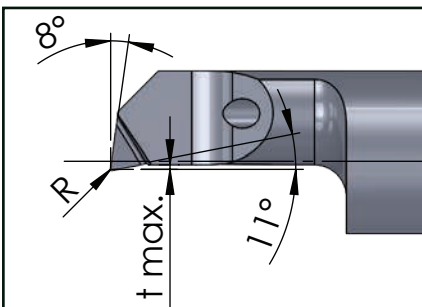

- Modifizierte Geometrie speziell für Materialien aus der Medizintechnik
- Innere Kühlmittelzufuhr
- Reduziertes t max. für höhere Stabilität
- Ausgezeichnete Oberflächenqualität der Schneide
- Eckenradius verspricht längere Standzeit und bessere Oberflächenqualität
- Modified geometry specifically designed for materials of medical technology
- Coolant delivered thru the tool
- Reduced t max. for higher stability
- Superior grinding surface quality
- Corner radius provides longer tool life and better surface finishes

ULTRAMINI

Bohrungsbearbeitung
ab \varnothing 0.2 mm

grooving, boring and profiling
starting at \varnothing 0.2 mm

Allgemeine Beschreibung

Superfinish, Mediline, Xtraline und Hardline

general instruction
Superfinish, Mediline, Xtraline und Hardline

Xtraline Typ X050

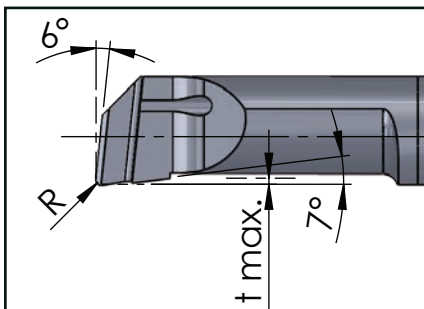

- Modifizierte Geometrie speziell für Nickel- und Chromlegierungen
- Innere Kühlmittelzufuhr
- Position der Kühlmittelzufuhr optimiert für beste Stabilität
- Reduziertes t max. für höhere Stabilität
- Variabler Eckenradius verspricht längere Standzeit und bessere Oberflächenqualität
- Spantreppe reduziert Schneidkräfte und ermöglicht höhere Schnittgeschwindigkeiten
- Modified geometry specifically designed for Nickel and Chrome based alloys
- Coolant delivered thru the tool
- Coolant hole location optimized for greatest tool rigidity
- Reduced t max. for higher stability
- Various corner radius provides for longer tool life and better surface finishes
- Chip breaker reduces cutting forces and provides for higher cutting feed

Hardline Typ 050

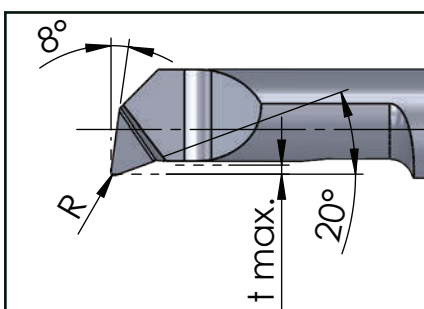

- Wirtschaftlicher als CBN
- Bis 66 HRC einsetzbar
- Optimal für dünnwandige Materialien
- Universell einsetzbar
- Scharfe Schneide
- Nur mit Kühlung arbeiten
- More economical than CBN
- Machine up to HRC 66
- Perfect for thin wall materials
- Very universal
- Sharp insert
- Don't use without cooling



ULTRAMINI

Bohrungsbearbeitung
ab Ø 0.2 mm

grooving, boring and profiling
starting at Ø 0.2 mm

Typ 645

Klemmhalter

toolholder

ab Ø 12 - 28 mm
für Schneideinsatz mit
D min. 0.2 - 5.0 mm

starting at Ø 12 - 28 mm
for insert with
D min. 0.2 - 5.0 mm

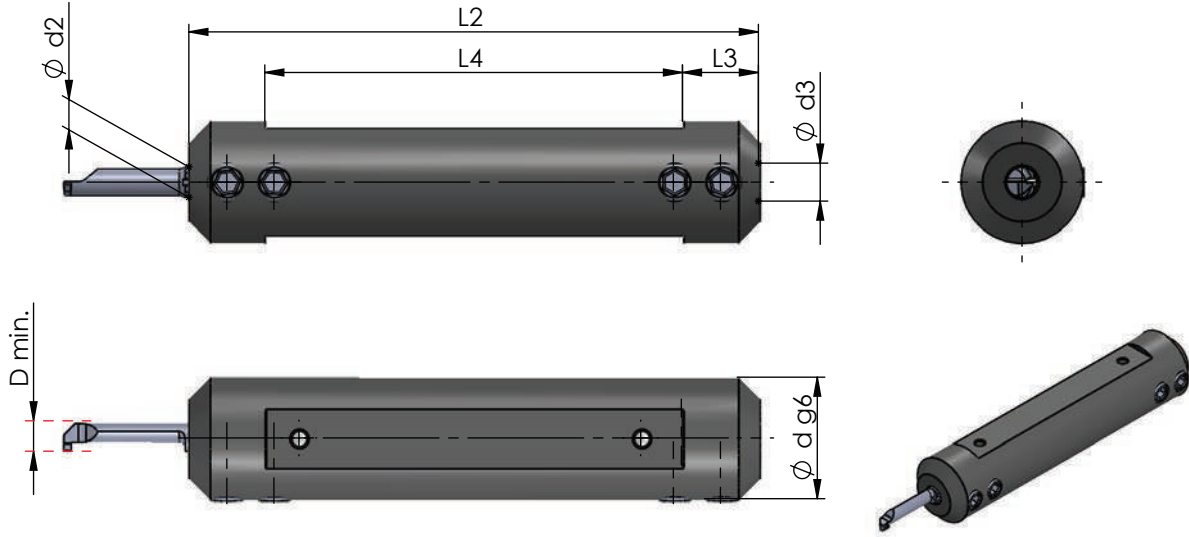

Klemmhalter für rechte und linke
Schneideinsätze einsetzbar

toolholder for right and left
inserts usable

Abmessungen in mm

dimensions in mm

Bestellnummer part number	Ø d g6	Ø d (inch)	L2	L3	L4	Spannschraube screw	Schraubenschlüssel wrench	Anzugs- drehmoment torque	Ø d2 ≤ Ø d h6 Schneideinsatz insert	Ø d3 ≤ Ø d h6 Schneideinsatz insert
645.0012-D	12		75	10	55	110.640	111.645	1.2 Nm	4	5
645.0016-D	16		75	10	55	110.645	111.645	1.2 Nm	4	5
645.0018-D	18		90	10	70	110.645	111.645	1.2 Nm	4	5
645.001905-D	19.05	3/4"	90	10	70	110.645	111.645	1.2 Nm	4	5
645.0020-D	20		90	10	70	110.650	111.645	1.2 Nm	4	5
645.0022-D	22		90	10	70	110.650	111.645	1.2 Nm	4	5
645.0025-D	25		95	10	75	110.650	111.645	1.2 Nm	4	5
645.00254-D	25.4	1"	95	10	75	110.650	111.645	1.2 Nm	4	5
645.0028-D	28		95	10	75	110.650	111.645	1.2 Nm	4	5

Bestellbeispiel:
645.0012-D

order-example:
645.0012-D

ULTRAMINI

Bohrungsbearbeitung
ab Ø 0.2 mm

grooving, boring and profiling
starting at Ø 0.2 mm

Typ 645.PT

Klemmhalter,
Premiumline mit
verbesserter Kühlung

toolholder,
Premiumline with
improved cooling

ab Ø 12 - 28 mm
für Schneideinsatz mit
D min. 0.2 - 5.0 mm

starting at Ø 12 - 28 mm
for insert with
D min. 0.2 - 5.0 mm

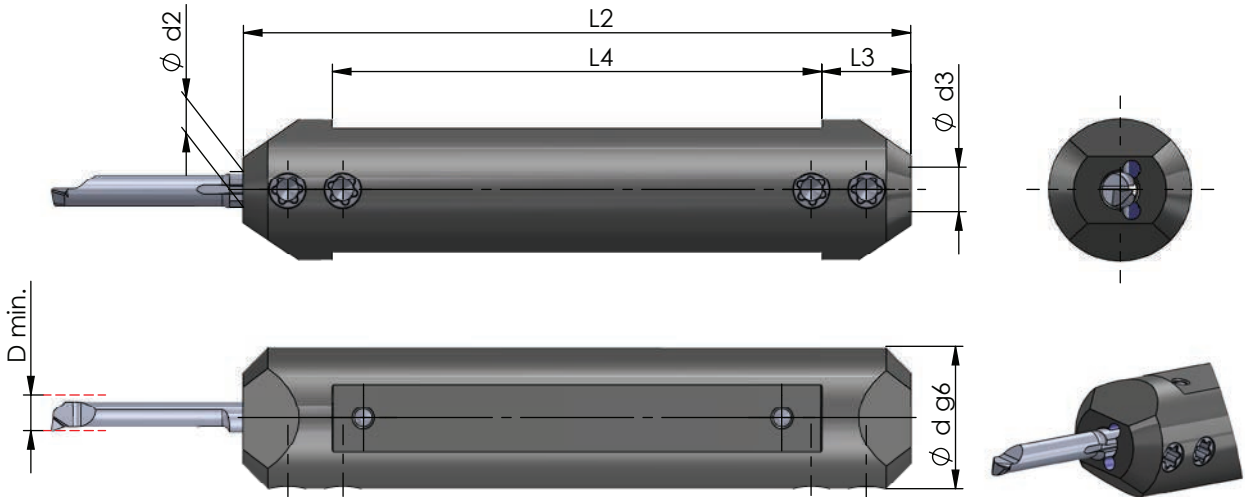

Klemmhalter für rechte und linke
Schneideinsätze einsetzbar

toolholder for right and left
inserts usable

Abmessungen in mm

dimensions in mm

Bestellnummer part number	Abmessungen in mm			dimensions in mm			Anzugs- drehmoment torque			Schneideinsatz insert	
	Ø d g6	Ø d (inch)	L2	L3	L4	Spannschraube screw	Schraubenschlüssel wrench	Anzugs- drehmoment torque	Ø d2 ≤ Ø d h6 Schneideinsatz insert	Ø d3 ≤ Ø d h6 Schneideinsatz insert	
645.PT12-D	12		75	10	55	PT12	T10F	1.2 Nm	4	5	
645.PT127-D	12.7	1/2"	75	10	55	PT12	T10F	1.2 Nm	4	5	
645.PT1587-D	15.87	5/8"	75	10	55	PT16	T10F	1.2 Nm	4	5	
645.PT16-D	16		75	10	55	PT16	T10F	1.2 Nm	4	5	
645.PT18-D	18		90	10	70	PT16	T10F	1.2 Nm	4	5	
645.PT1905-D	19.05	3/4"	90	10	70	PT16	T10F	1.2 Nm	4	5	
645.PT20-D	20		90	10	70	PT20	T10F	1.2 Nm	4	5	
645.PT22-D	22		90	10	70	PT20	T10F	1.2 Nm	4	5	
645.PT25-D	25		95	10	75	PT20	T10F	1.2 Nm	4	5	
645.PT254-D	25.4	1"	95	10	75	PT20	T10F	1.2 Nm	4	5	
645.PT28-D	28		95	10	75	PT20	T10F	1.2 Nm	4	5	

Bestellbeispiel:
645.PT12-D

order-example:
645.PT12-D

ULTRAMINI

Bohrungsbearbeitung
ab Ø 0.2 mm

grooving, boring and profiling
starting at Ø 0.2 mm

Typ 676

Klemmhalter

toolholder

ab Ø 16 - 28 mm
für Schneideinsatz mit
D min. 6.0 - 7.0 mm

starting at Ø 16 - 28 mm
for insert with
D min. 6.0 - 7.0 mm

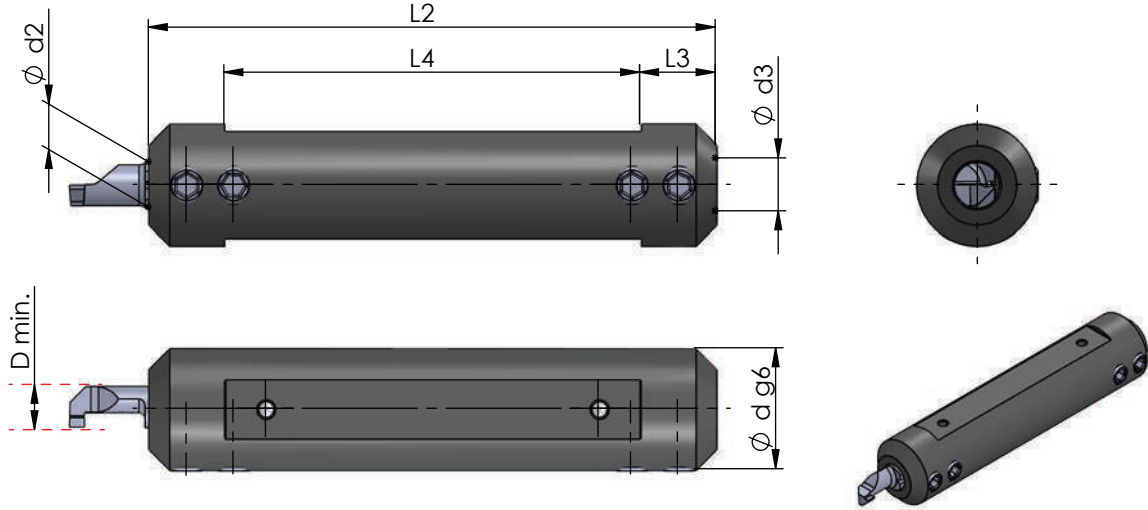

Klemmhalter für rechte und linke
Schneideinsätze einsetzbar

toolholder for right and left
inserts usable

Abmessungen in mm

dimensions in mm

Bestellnummer part number	Abmessungen in mm			dimensions in mm			Spannschraube screw	Schraubenschlüssel wrench	Anzugs- drehmoment torque	Schneideinsatz insert	
	Ø d g6	Ø d (inch)	L2	L3	L4	Ø d2 ≤				Ø d h6 Schneideinsatz insert	Ø d3 ≤
676.0016-D	16		75	10	55	110.645	111.645	1.2 Nm	6	7	
676.0018-D	18		90	10	70	110.645	111.645	1.2 Nm	6	7	
676.001905-D	19.05	3/4"	90	10	70	110.645	111.645	1.2 Nm	6	7	
676.0020-D	20		90	10	70	110.650	111.645	1.2 Nm	6	7	
676.0022-D	22		90	10	70	110.650	111.645	1.2 Nm	6	7	
676.0025-D	25		95	10	75	110.650	111.645	1.2 Nm	6	7	
676.00254-D	25.4	1"	95	10	75	110.650	111.645	1.2 Nm	6	7	
676.0028-D	28		95	10	75	110.650	111.645	1.2 Nm	6	7	

Bestellbeispiel:
676.0016-D

order-example:
676.0016-D

ULTRAMINI

Bohrungsbearbeitung
ab Ø 0.2 mm

grooving, boring and profiling
starting at Ø 0.2 mm

Typ 676.PT

Klemmhalter,
Premiumline mit
verbesserter Kühlung

toolholder,
Premiumline with
improved cooling

ab Ø 15.87 - 28 mm
für Schneideinsatz mit
D min. 6.0 - 7.0 mm

starting at Ø 15.87 - 28 mm
for insert with
D min. 6.0 - 7.0 mm

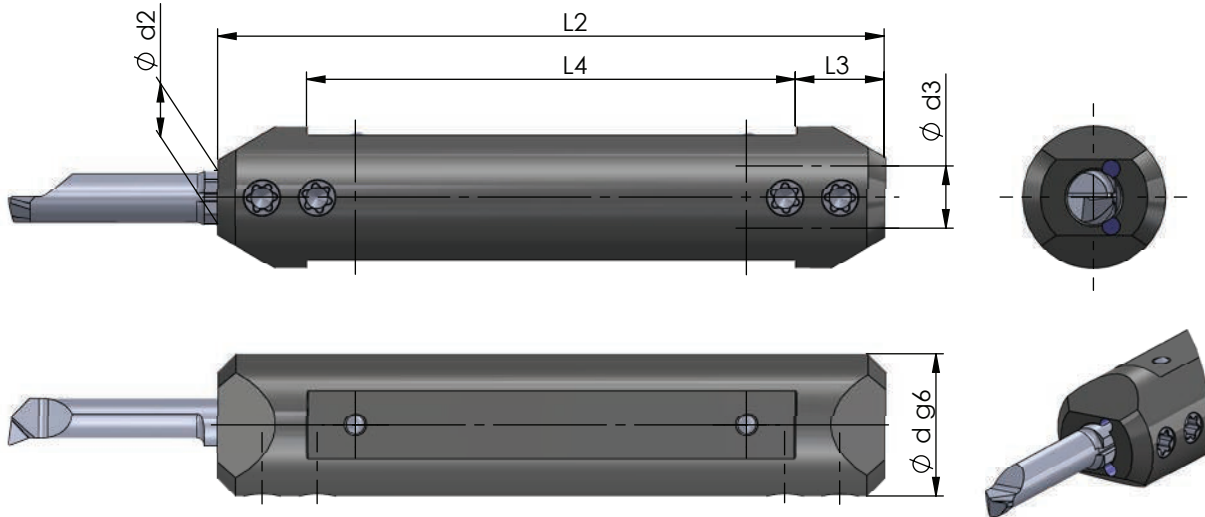

Klemmhalter für rechte und linke
Schneideinsätze einsetzbar

toolholder for right and left
inserts usable

Abmessungen in mm

dimensions in mm

Bestellnummer part number	Abmessungen in mm					dimensions in mm			dimensions in mm	
	Ø d g6	Ø d (inch)	L2	L3	L4	Spannschraube screw	Schraubenschlüssel wrench	Anzugs- drehmoment torque	Ø d2 ≤ Ø d h6 Schneideinsatz insert	Ø d3 ≤ Ø d h6 Schneideinsatz insert
676.PT1587-D	15.87	5/8"	75	10	55	PT16	T10F	1.2 Nm	6	7
676.PT16-D	16		75	10	55	PT16	T10F	1.2 Nm	6	7
676.PT18-D	18		90	10	70	PT16	T10F	1.2 Nm	6	7
676.PT1905-D	19.05	3/4"	90	10	70	PT16	T10F	1.2 Nm	6	7
676.PT20-D	20		90	10	70	PT20	T10F	1.2 Nm	6	7
676.PT22-D	22		90	10	70	PT20	T10F	1.2 Nm	6	7
676.PT25-D	25		95	10	75	PT20	T10F	1.2 Nm	6	7
676.PT254-D	25.4	1"	95	10	75	PT20	T10F	1.2 Nm	6	7
676.PT28-D	28		95	10	75	PT20	T10F	1.2 Nm	6	7

Bestellbeispiel:
676.PT16-D

order-example:
676.PT16-D

ULTRAMINI

Bohrungsbearbeitung
ab Ø 0.2 mm

grooving, boring and profiling
starting at Ø 0.2 mm

Typ 687 / 681

Klemmhalter

toolholder

ab Ø 16 - 20 mm
für Schneideinsatz mit D min. 6.8 - 7.8 mm
und D min. 7.8 - 10.5 mm

starting at Ø 16 - 20 mm
for insert with D min. 6.8 - 7.8 mm
and D min. 7.8 - 10.5 mm

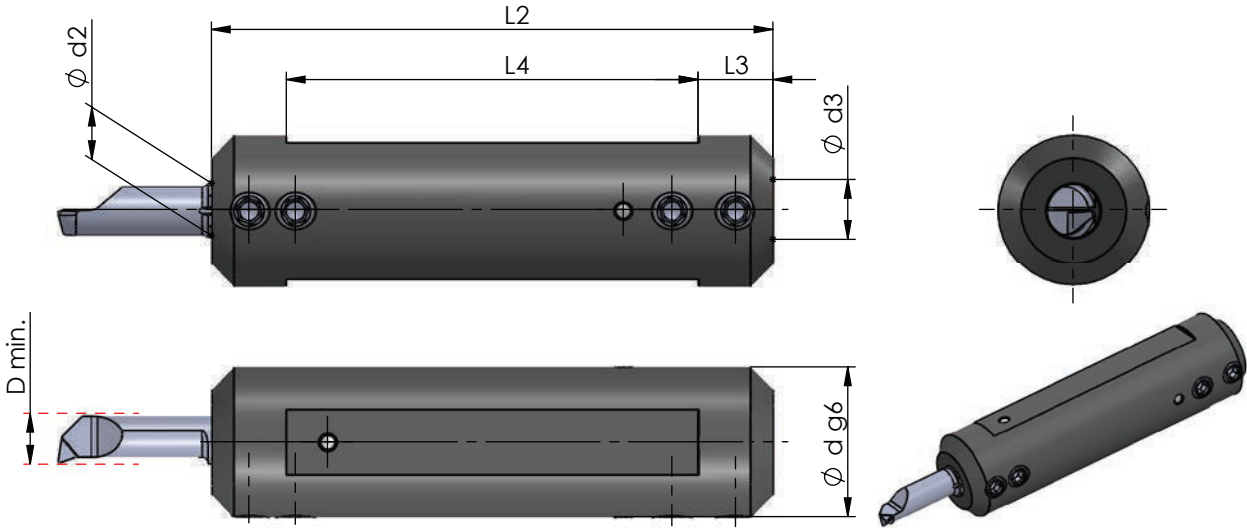

Klemmhalter für rechte und linke
Schneideinsätze einsetzbar

toolholder for right and left
inserts usable

Abmessungen in mm

dimensions in mm

Bestellnummer part number	Abmessungen in mm				Spannschraube screw	Schraubenschlüssel wrench	Anzugs- drehmoment torque	Schneideinsatz insert	
	Ø d g6	L2	L3	L4				Ø d2 ≤	Ø d h6 Schneideinsatz insert
687.0016-D	16	75	10	55	110.687-16	111.687	2.5 Nm	7	8
687.0020-D	20	90	10	70	110.687-16	111.687	2.5 Nm	7	8
681.0020-D	20	100	10	80	110.640	111.645	1.2 Nm	8	10

Bestellbeispiel:
687.0016-D

order-example:
687.0016-D

ULTRAMINI

Bohrungsbearbeitung
ab $\varnothing 0.2$ mm

grooving, boring and profiling
starting at $\varnothing 0.2$ mm

Typ 687.PT

Klemmhalter,
Premiumline mit
verbesserter Kühlung

toolholder,
Premiumline with
improved cooling

ab $\varnothing 16 - 20$ mm
für Schneideinsatz mit
D min. 6.8 - 7.8 mm

starting at $\varnothing 16 - 20$ mm
for insert with
D min. 6.8 - 7.8 mm

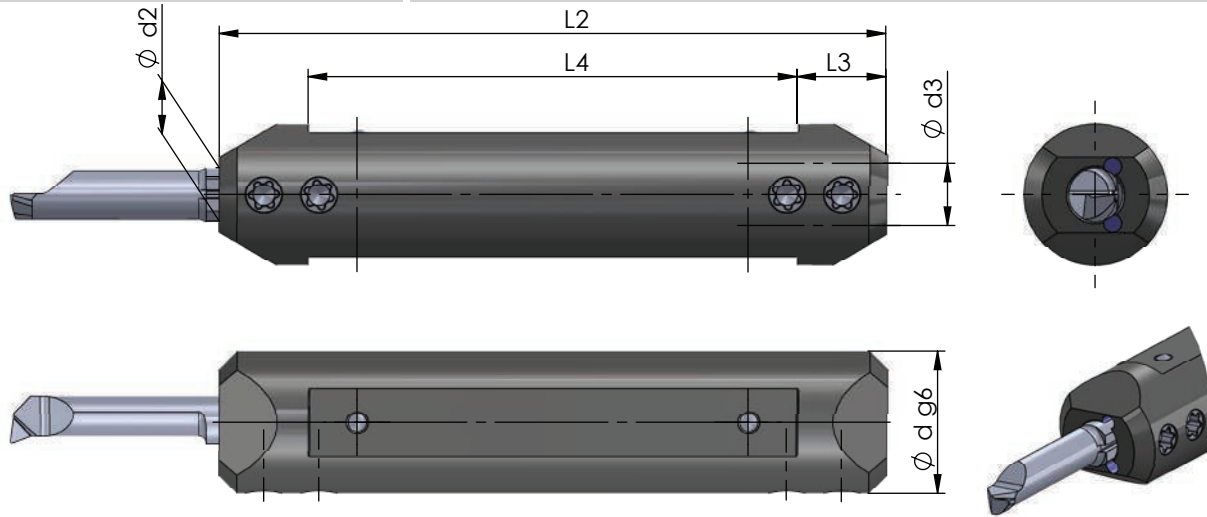

Klemmhalter für rechte und linke
Schneideinsätze einsetzbar

toolholder for right and left
inserts usable

Abmessungen in mm

dimensions in mm

Bestellnummer part number	Abmessungen in mm				Spannschraube screw	Schraubenschlüssel wrench	Anzugs- drehmoment torque	Schneideinsatz insert	
	$\varnothing d g6$	L2	L3	L4				$\varnothing d2$	$\varnothing d h6$
687.PT16-D	16	75	10	55	PT12	T10F	1.2 Nm	7	8
687.PT20-D	20	90	10	70	PT16	T10F	1.2 Nm	7	8

Bestellbeispiel:
687.PT16-D

order-example:
687.PT16-D

ULTRAMINI

Bohrungsbearbeitung
ab Ø 0.2 mm

grooving, boring and profiling
starting at Ø 0.2 mm

Typ 640 / 650 / 660 / 670 / 680

Klemmhalter

toolholder

ab Ø 12 / 12.7 mm
für Schneideinsatz mit
D min. 0.2 - 7.8 mm

starting at Ø 12 / 12.7 mm
for insert with
D min. 0.2 - 7.8 mm

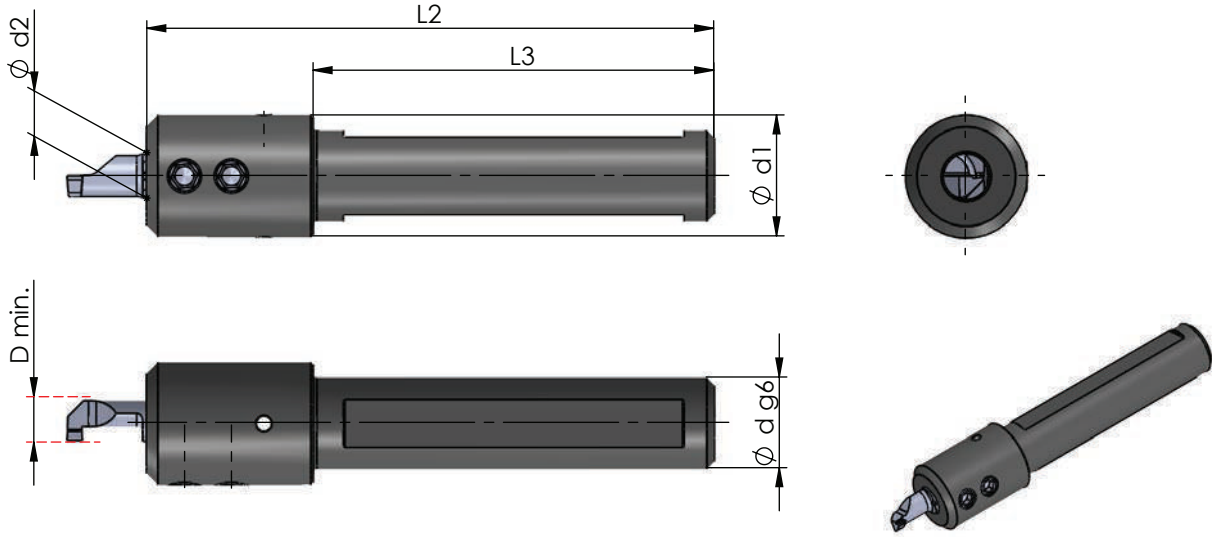

Klemmhalter für rechte und linke
Schneideinsätze einsetzbar

toolholder for right and left
inserts usable

Abmessungen in mm

dimensions in mm

Bestellnummer part number	Ø d g6	Ø d (inch)	L2	Ø d1	L3	Spannschraube screw	Schraubenschlüssel wrench	Anzugs- drehmoment torque	Ø d2 Ø d h6 Schneideinsatz insert
640.0012	12		75	16	53	G016	111.645	1.2 Nm	4
650.0012	12		75	16	53	G016	111.645	1.2 Nm	5
660.0012	12		75	16	53	G016	111.645	1.2 Nm	6
660.0127	12.7	1/2"	75	16	53	G016	111.645	1.2 Nm	6
670.0012	12		75	16	53	G016	111.645	1.2 Nm	7
670.0127	12.7	1/2"	75	16	53	G016	111.645	1.2 Nm	7
680.0012	12		75	16	53	G016	111.645	1.2 Nm	8
680.0127	12.7	1/2"	75	16	53	G016	111.645	1.2 Nm	8

Bestellbeispiel:
640.0012

order-example:
640.0012

ULTRAMINI

Bohrungsbearbeitung
ab $\varnothing 0.2$ mm

grooving, boring and profiling
starting at $\varnothing 0.2$ mm

Typ 645.K

Klemmhalter, ideal für Typ 520
und mit zentraler Kühlbohrung

toolholder, perfect for type 520
and with central cooling bore

ab $\varnothing 12 - 20$ mm
für Schneideinsatz mit
D min. 0.2 - 5.0 mm

starting at $\varnothing 12 - 20$ mm
for insert with
D min. 0.2 - 5.0 mm

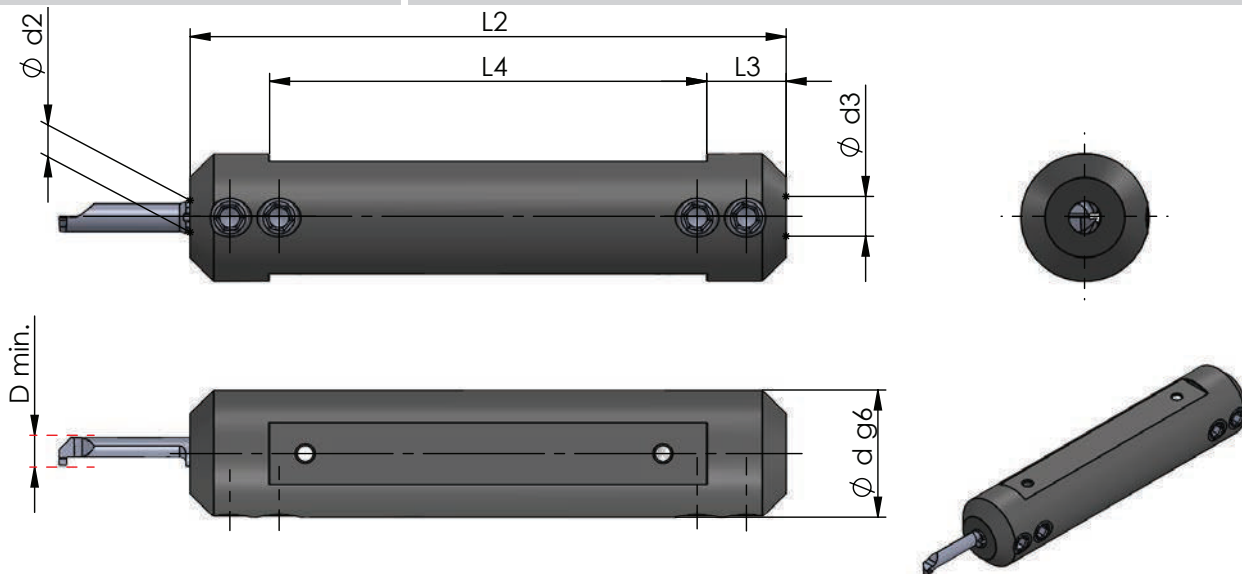

Klemmhalter für rechte und linke
Schneideinsätze einsetzbar

toolholder for right and left
inserts usable

Abmessungen in mm

dimensions in mm

Bestellnummer part number	$\varnothing d6$	L2	L3	L4	Spannschraube screw	Schraubenschlüssel wrench	Anzugs- drehmoment torque	Schneideinsatz insert	
								$\varnothing d2$	$\varnothing d3$
645.K012-D	12	75	10	55	110.640	111.645	1.2 Nm	4	5
645.K016-D	16	75	10	55	110.645	111.645	1.2 Nm	4	5
645.K020-D	20	90	10	70	110.650	111.645	1.2 Nm	4	5

Bestellbeispiel:
645.K012-D

order-example:
645.K012-D

ULTRAMINI

Bohrungsbearbeitung
ab Ø 0.2 mm

grooving, boring and profiling
starting at Ø 0.2 mm

Typ 676.K

Klemmhalter, ideal für Typ 520
und mit zentraler Kühlbohrung

toolholder, perfect for type 520
and with central cooling bore

ab Ø 16 - 20 mm
für Schneideinsatz mit
D min. 6.0 - 7.0 mm

starting at Ø 16 - 20 mm
for insert with
D min. 6.0 - 7.0 mm

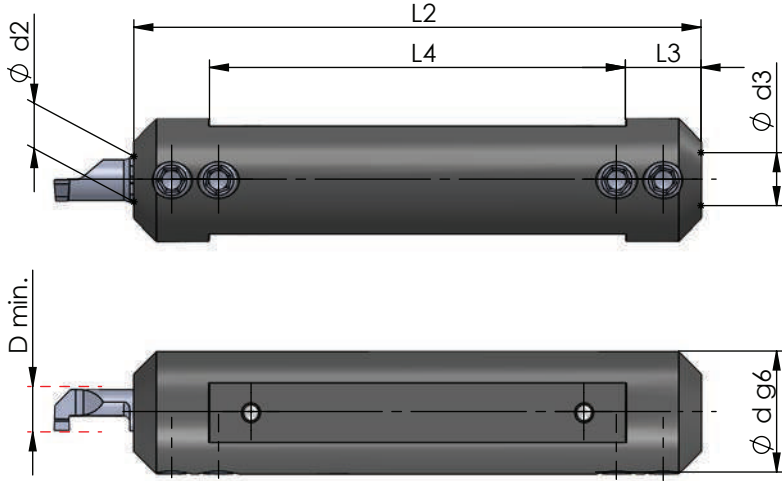

Klemmhalter für rechte und linke
Schneideinsätze einsetzbar

toolholder for right and left
inserts usable

Abmessungen in mm

dimensions in mm

Bestellnummer part number	Abmessungen in mm				Spannschraube screw	Schraubenschlüssel wrench	Anzugs- drehmoment torque	Schneideinsatz insert	
	Ø d g6	L2	L3	L4				Ø d2 ≤ Ø d h6	Ø d3 ≤ Ø d h6
676.K016-D	16	75	10	55	110.645	111.645	1.2 Nm	6	7
676.K020-D	20	90	10	70	110.650	111.645	1.2 Nm	6	7

Bestellbeispiel:
676.K016-D

order-example:
676.K016-D

ULTRAMINI

Bohrungsbearbeitung
ab Ø 0.2 mm

grooving, boring and profiling
starting at Ø 0.2 mm

Typ UMST

Klemmhalter,
mit Hochdruckanschluss
für Langdreher

toolholder,
with high-pressure connection
for Swiss type Machines

ab Ø 16 - 28 mm
für Schneideinsatz mit
D min. 0.2 - 7.8 mm

starting at Ø 16 - 28 mm
for insert with
D min. 0.2 - 7.8 mm

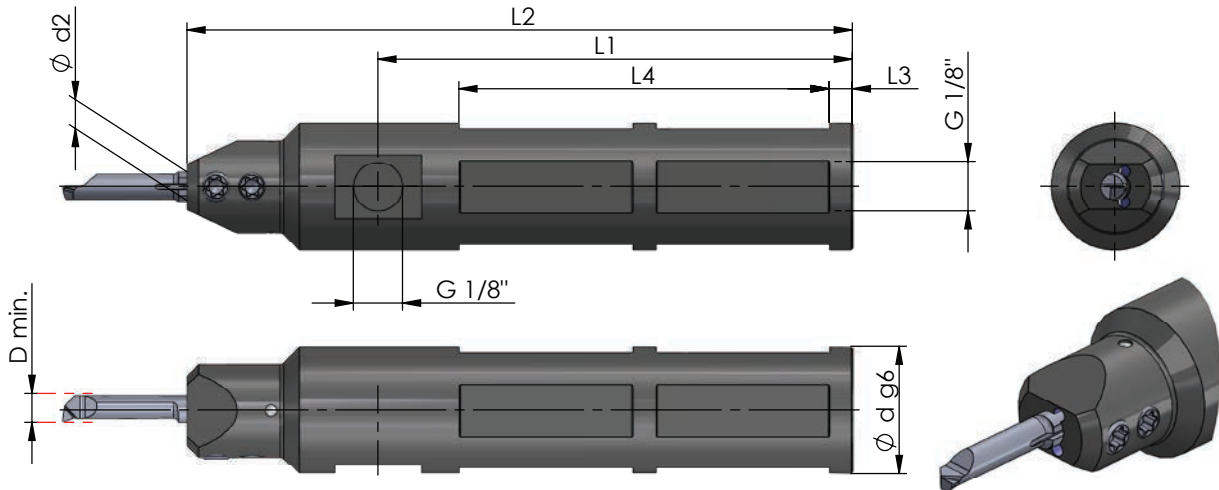

Klemmhalter für rechte und linke
Schneideinsätze einsetzbar

toolholder for right and left
inserts usable

Abmessungen in mm

dimensions in mm

Bestellnummer part number	Ø d g6		L1	L2	L3	L4	Spannschraube screw	Schrauben- schlüssel wrench	Anzugs- drehmoment torque	Schneideinsatz insert	
	Ø d2	Ø d h6									
UMST.0016.4	16		82	115	4	64	PT16	T10F	1.2 Nm	4	
UMST.0016.5	16		82	115	4	64	PT16	T10F	1.2 Nm	5	
UMST.0016.6	16		82	115	4	64	PT16	T10F	1.2 Nm	6	
UMST.0016.7	16		82	115	4	64	PT16	T10F	1.2 Nm	7	
UMST.0016.8	16		82	115	4	64	PT16	T10F	1.2 Nm	8	
UMST.001905.4	19.05	3/4"	82	115	4	64	PT16	T10F	1.2 Nm	4	
UMST.001905.5	19.05	3/4"	82	115	4	64	PT16	T10F	1.2 Nm	5	
UMST.001905.6	19.05	3/4"	82	115	4	64	PT16	T10F	1.2 Nm	6	
UMST.001905.7	19.05	3/4"	82	115	4	64	PT16	T10F	1.2 Nm	7	
UMST.001905.8	19.05	3/4"	82	115	4	64	PT16	T10F	1.2 Nm	8	
UMST.0020.4	20		82	115	4	64	PT16	T10F	1.2 Nm	4	
UMST.0020.5	20		82	115	4	64	PT16	T10F	1.2 Nm	5	
UMST.0020.6	20		82	115	4	64	PT16	T10F	1.2 Nm	6	
UMST.0020.7	20		82	115	4	64	PT16	T10F	1.2 Nm	7	
UMST.0020.8	20		82	115	4	64	PT16	T10F	1.2 Nm	8	
↳ ...											

Bestellbeispiel:
UMST.0016.4

order-example:
UMST.0016.4

ULTRAMINI

Bohrungsbearbeitung
ab Ø 0.2 mm

grooving, boring and profiling
starting at Ø 0.2 mm

Typ UMST

Klemmhalter,
mit Hochdruckanschluss
für Langdreher

toolholder,
with high-pressure connection
for Swiss type Machines

ab Ø 16 - 28 mm
für Schneideinsatz mit
D min. 0.2 - 7.8 mm

starting at Ø 16 - 28 mm
for insert with
D min. 0.2 - 7.8 mm

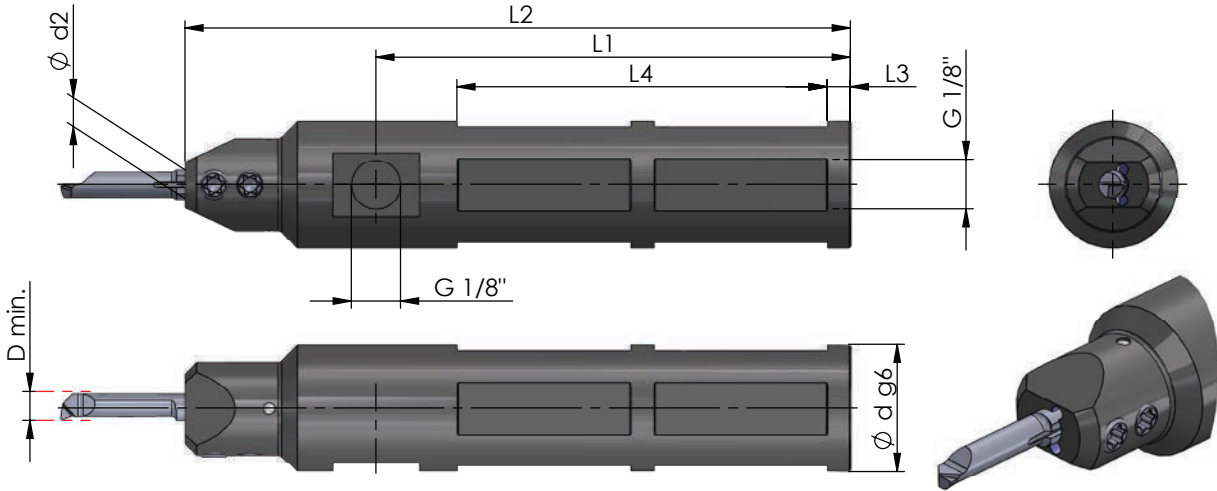

Klemmhalter für rechte und linke
Schneideinsätze einsetzbar

toolholder for right and left
inserts usable

Abmessungen in mm

dimensions in mm

Bestellnummer part number	Ø d g6	Ø d (inch)	L1	L2	L3	L4	Spannschraube screw	Schrauben- schlüssel wrench	Anzugs- drehmoment torque	Ø d2 Ø d h6 Schneideinsatz insert
⋮ ↴										
UMST.0022.4	22		82	115	4	64	PT16	T10F	1.2 Nm	4
UMST.0022.5	22		82	115	4	64	PT16	T10F	1.2 Nm	5
UMST.0022.6	22		82	115	4	64	PT16	T10F	1.2 Nm	6
UMST.0022.7	22		82	115	4	64	PT16	T10F	1.2 Nm	7
UMST.0022.8	22		82	115	4	64	PT16	T10F	1.2 Nm	8
UMST.00254.4	25.4	1"	82	115	4	64	PT16	T10F	1.2 Nm	4
UMST.00254.5	25.4	1"	82	115	4	64	PT16	T10F	1.2 Nm	5
UMST.00254.6	25.4	1"	82	115	4	64	PT16	T10F	1.2 Nm	6
UMST.00254.7	25.4	1"	82	115	4	64	PT16	T10F	1.2 Nm	7
UMST.00254.8	25.4	1"	82	115	4	64	PT16	T10F	1.2 Nm	8
UMST.0028.4	28		82	115	4	64	PT16	T10F	1.2 Nm	4
UMST.0028.5	28		82	115	4	64	PT16	T10F	1.2 Nm	5
UMST.0028.6	28		82	115	4	64	PT16	T10F	1.2 Nm	6
UMST.0028.7	28		82	115	4	64	PT16	T10F	1.2 Nm	7
UMST.0028.8	28		82	115	4	64	PT16	T10F	1.2 Nm	8

Bestellbeispiel:
UMST.0022.4

order-example:
UMST.0022.4

ULTRAMINI

Bohrungsbearbeitung
ab $\varnothing 0.2$ mm

grooving, boring and profiling
starting at $\varnothing 0.2$ mm

Typ UM600H

High-Performance-Klemmhalter
mit Kühlmittelsanschluss

high-performance toolholder
with coolant connection

ab $\varnothing 12 - 28$ mm
für Schneideinsatz mit
D min. 0.2 - 7.0 mm

starting at $\varnothing 12 - 28$ mm
for insert with
D min. 0.2 - 7.0 mm

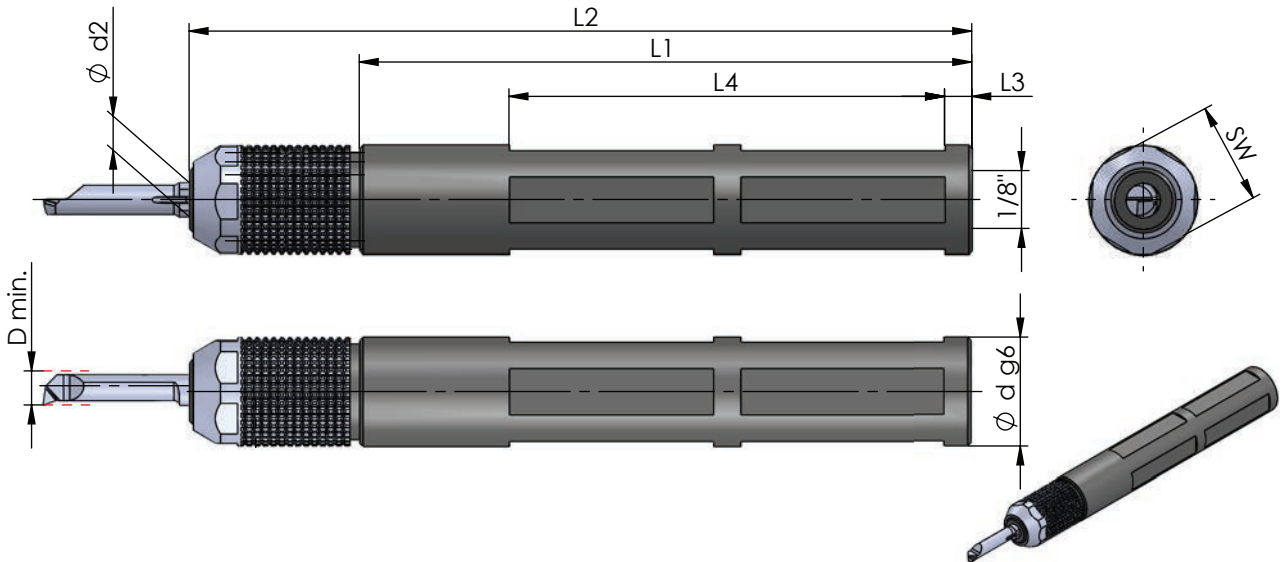

Klemmhalter für rechte und linke
Schneideinsätze einsetzbar

toolholder for right and left
inserts usable

Abmessungen in mm

dimensions in mm

Bestellnummer part number	$\varnothing d g6$	$\varnothing d$ (inch)	L2	L1	L3	L4	Überwurfmutter union nut	Klemmkeil nut	Schneideinsatz insert	
									$\varnothing d2$	$\varnothing d h6$
UM600H.0012.4	12		115	90	4	64	UM600H.M4	UM600H.K	4	
UM600H.0012.5	12		115	90	4	64	UM600H.M5	UM600H.K	5	
UM600H.0012.6	12		115	90	4	64	UM600H.M6	UM600H.K	6	
UM600H.0012.7	12		115	90	4	64	UM600H.M7	UM600H.K	7	
UM600H.0016.4	16		115	90	4	64	UM600H.M4	UM600H.K	4	
UM600H.0016.5	16		115	90	4	64	UM600H.M5	UM600H.K	5	
UM600H.0016.6	16		115	90	4	64	UM600H.M6	UM600H.K	6	
UM600H.0016.7	16		115	90	4	64	UM600H.M7	UM600H.K	7	

↳ ...

Merkmale:

- Handspannung ohne zusätzlichen Schlüssel
- Wiederholgenauigkeit $\pm 0,005$ mm (hohe Präzision)
- einfachste Bedienung
- ideal bei engen Platzverhältnissen
- Spannung mit Standardschlüssel SW15 möglich
- bei Einsatz von Rückwärtsdreher oder Hochdruckkühlung muss mit Schlüssel gespannt werden

characteristics:

- manual clamping without additional wrench
- continuous repeatability $\pm 0,005$ mm (high precision)
- simplest operation
- ideal where space is tight
- clamping by standard wrench SW15 is possible
- when backboring or high-pressure cooling you have to clamp with a wrench

Bestellbeispiel:
UM600H.0012.4

order-example:
UM600H.0012.4

ULTRAMINI

Bohrungsbearbeitung
ab Ø 0.2 mm

grooving, boring and profiling
starting at Ø 0.2 mm

Typ UM600H

High-Performance-Klemmhalter
mit Kühlmittelsanschluss

high-performance toolholder
with coolant connection

ab Ø 12 - 28 mm
für Schneideinsatz mit
D min. 0.2 - 7.0 mm

starting at Ø 12 - 28 mm
for insert with
D min. 0.2 - 7.0 mm

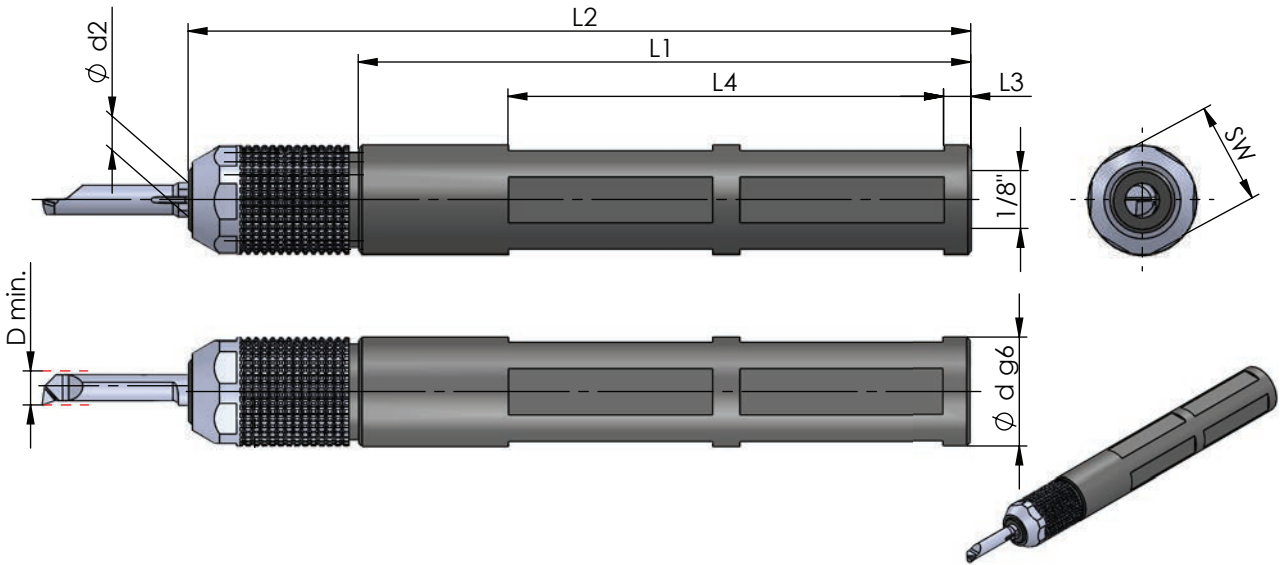

Klemmhalter für rechte und linke
Schneideinsätze einsetzbar

toolholder for right and left
inserts usable

Abmessungen in mm

dimensions in mm

Bestellnummer part number	Ø d g6		L2	L1	L3	L4	Überwurfmutter union nut	Klemmkeil nut	Ø d2 Ø d h6 Schneideinsatz insert
	Ø d (inch)								
⋮ ↴									
UM600H.001905.4	19.05	3/4"	115	90	4	64	UM600H.M4	UM600H.K	4
UM600H.001905.5	19.05	3/4"	115	90	4	64	UM600H.M5	UM600H.K	5
UM600H.001905.6	19.05	3/4"	115	90	4	64	UM600H.M6	UM600H.K	6
UM600H.001905.7	19.05	3/4"	115	90	4	64	UM600H.M7	UM600H.K	7
UM600H.0020.4	20		115	90	4	64	UM600H.M4	UM600H.K	4
UM600H.0020.5	20		115	90	4	64	UM600H.M5	UM600H.K	5
UM600H.0020.6	20		115	90	4	64	UM600H.M6	UM600H.K	6
UM600H.0020.7	20		115	90	4	64	UM600H.M7	UM600H.K	7
UM600H.0022.4	22		115	90	4	64	UM600H.M4	UM600H.K	4
UM600H.0022.5	22		115	90	4	64	UM600H.M5	UM600H.K	5
UM600H.0022.6	22		115	90	4	64	UM600H.M6	UM600H.K	6
UM600H.0022.7	22		115	90	4	64	UM600H.M7	UM600H.K	7
↳ ...									

Bestellbeispiel:
UM600H.001905.4

order-example:
UM600H.001905.4

ULTRAMINI

Bohrungsbearbeitung
ab Ø 0.2 mm

grooving, boring and profiling
starting at Ø 0.2 mm

Typ UM600H

High-Performance-Klemmhalter
mit Kühlmittelsanschluss

high-performance toolholder
with coolant connection

ab Ø 12 - 28 mm
für Schneideinsatz mit
D min. 0.2 - 7.0 mm

starting at Ø 12 - 28 mm
for insert with
D min. 0.2 - 7.0 mm

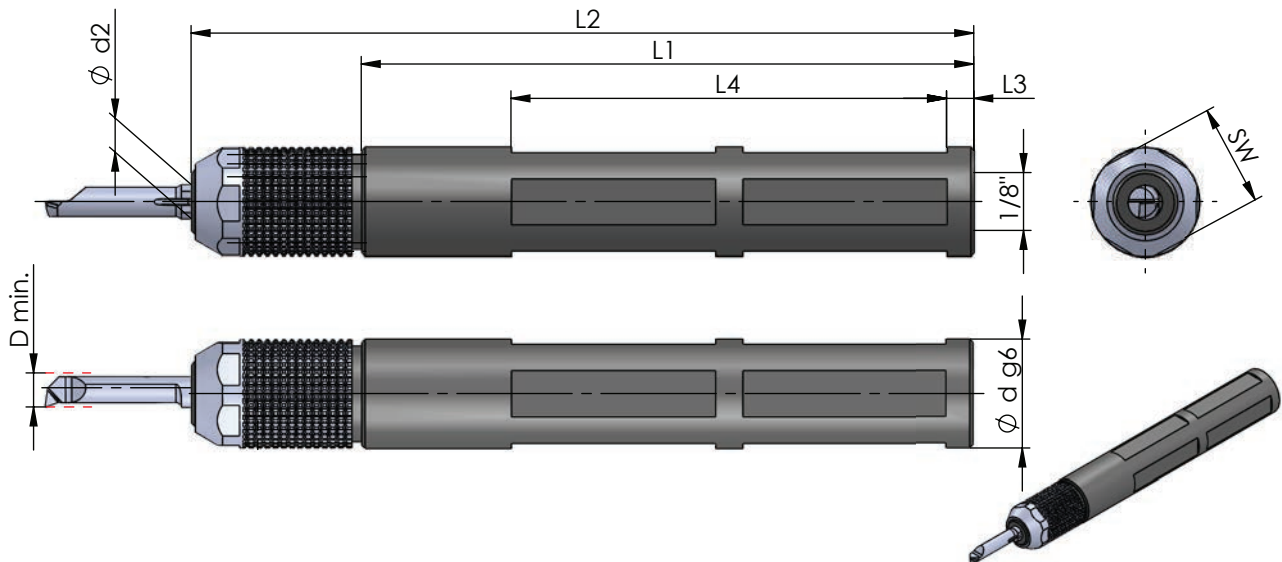

Klemmhalter für rechte und linke
Schneideinsätze einsetzbar

toolholder for right and left
inserts usable

Abmessungen in mm

dimensions in mm

Bestellnummer part number	Ø d g6	Ø d (inch)	L2	L1	L3	L4	Überwurfmutter union nut	Klemmkeil nut	Ø d2 Ø d h6 Schneideinsatz insert
...									
UM600H.0025.4	25		115	90	4	64	UM600H.M4	UM600H.K	4
UM600H.0025.5	25		115	90	4	64	UM600H.M5	UM600H.K	5
UM600H.0025.6	25		115	90	4	64	UM600H.M6	UM600H.K	6
UM600H.0025.7	25		115	90	4	64	UM600H.M7	UM600H.K	7
UM600H.00254.4	25.4	1"	115	90	4	64	UM600H.M4	UM600H.K	4
UM600H.00254.5	25.4	1"	115	90	4	64	UM600H.M5	UM600H.K	5
UM600H.00254.6	25.4	1"	115	90	4	64	UM600H.M6	UM600H.K	6
UM600H.00254.7	25.4	1"	115	90	4	64	UM600H.M7	UM600H.K	7
UM600H.0028.4	28		115	90	4	64	UM600H.M4	UM600H.K	4
UM600H.0028.5	28		115	90	4	64	UM600H.M5	UM600H.K	5
UM600H.0028.6	28		115	90	4	64	UM600H.M6	UM600H.K	6
UM600H.0028.7	28		115	90	4	64	UM600H.M7	UM600H.K	7

Bestellbeispiel:
UM600H.0025.4

order-example:
UM600H.0025.4

ULTRAMINI

Bohrungsbearbeitung
ab $\varnothing 0.2$ mm

grooving, boring and profiling
starting at $\varnothing 0.2$ mm

Typ UM

Klemhalter,
Quadratschaft

toolholder,
square shank

ab 10.0 x 10.0 mm
für Schneideinsätze
D min. 0.2 - 7.0 mm

starting at 10.0 x 10.0 mm
for insert
D min. 0.2 - 7.0 mm

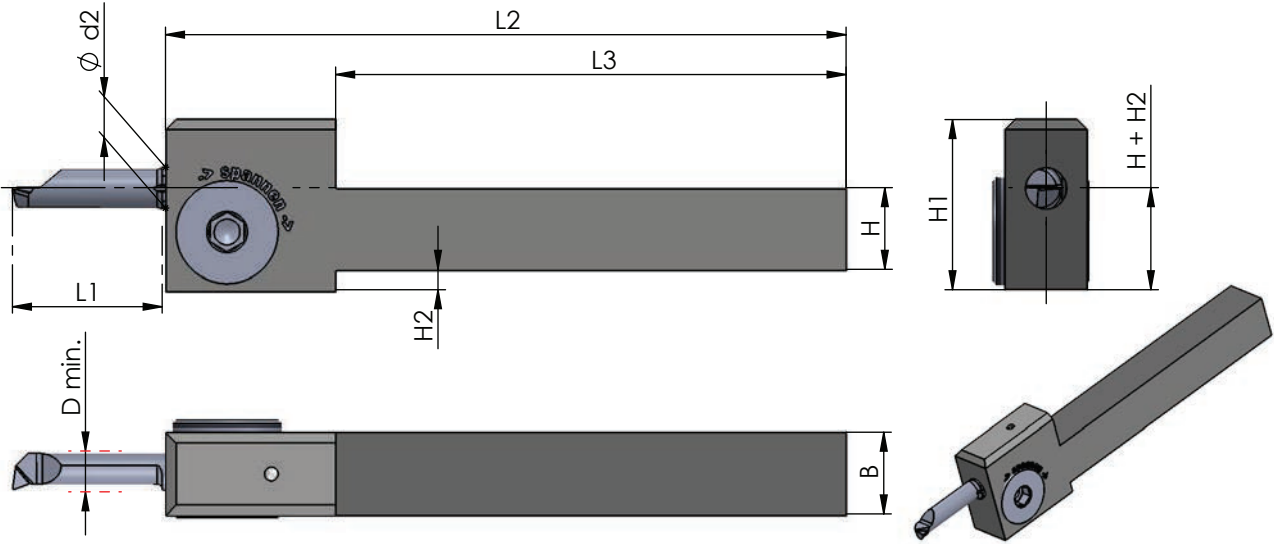

Klemhalter für rechte und linke
Schneideinsätze einsetzbar

toolholder for right and left
inserts usable

Abmessungen in mm

dimensions in mm

Bestellnummer part number	H	B	L2	L3	H1	H2	L1 Schneide / insert	Klemmelement locking element	Schraubenschlüssel wrench	Anzugs- drehmoment torque	$\varnothing d2$	$\varnothing d h6$	Schneideinsatz insert
											\leq		
UM.1010.4	10	10	100	75	22	2		UM12	111.INB5	2.0 NM			4
UM.1010.5	10	10	100	75	22	2		UM12	111.INB5	2.0 NM			5
UM.1212.4	12	12	100	75	22			UM12	111.INB5	2.0 NM			4
UM.1212.5	12	12	100	75	22			UM12	111.INB5	2.0 NM			5
UM.1212.6	12	12	100	75	25	3	-2	UM16	111.INB5	2.0 NM			6
UM.1616.4	16	16	125	100	25			UM12	111.INB5	2.0 NM			4
UM.1616.5	16	16	125	100	25			UM12	111.INB5	2.0 NM			5
UM.1616.6	16	16	125	100	25		-2	UM16	111.INB5	2.0 NM			6
UM.1616.7	16	16	125	100	25		-2	UM16	111.INB5	2.0 NM			7

Bestellbeispiel:
UM.1010.4

order-example:
UM.1010.4

ULTRAMINI

Bohrungsbearbeitung
ab $\varnothing 0.2$ mm

grooving, boring and profiling
starting at $\varnothing 0.2$ mm

Typ .IK.UHCM

Klemmhalter,
Quadratschaft,
mit Innenkühlung

toolholder,
square shank,
with internal cooling

ab 12.0 x 12.0 mm
für Schneideinsätze
D min. 0.2 - 7.0 mm

starting at 12.0 x 12.0 mm
for insert
D min. 0.2 - 7.0 mm

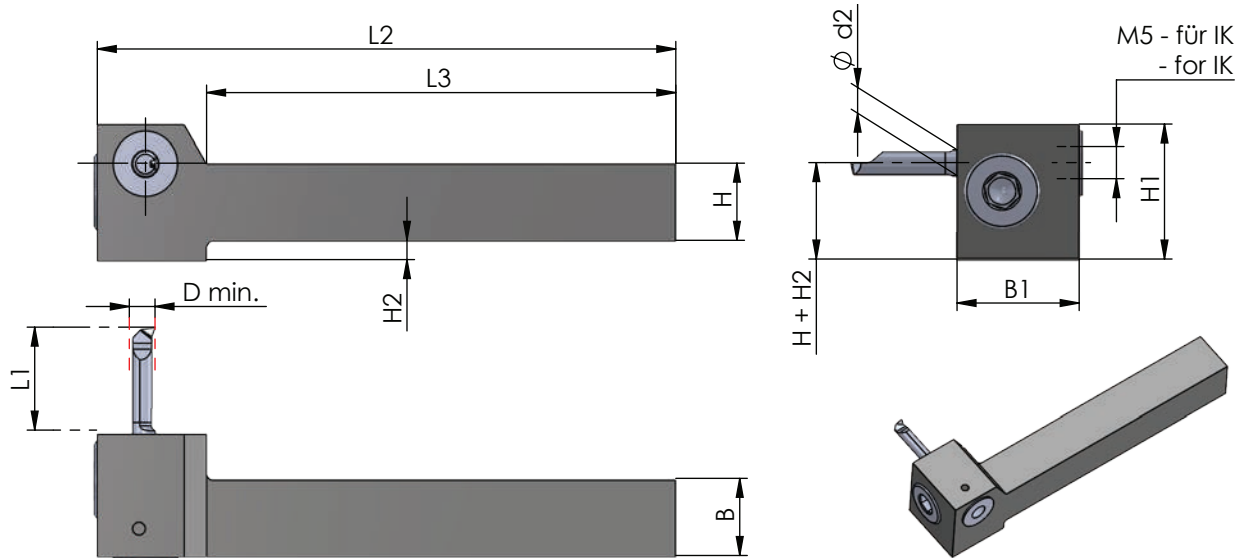

Klemmhalter für rechte und linke
Schneideinsätze einsetzbar

Abbildung: linksschneidend

Abmessungen in mm

toolholder for right and left
inserts usable

lefthand version shown

dimensions in mm

Bestellnummer part number	H	B	L2	L3	B1	H1	H2	L1	Schneide / insert	Klemmelement locking element	Schraubenschlüssel wrench	Anzugs- drehmoment torque	$\varnothing d2$ $\varnothing d h6$ Schneideinsatz insert
R/L .IK.UHCM.1212.4	12	12	90	73	20	18				UM12	111.INB5	2.0 NM	4
R/L .IK.UHCM.1212.5	12	12	90	73	20	18				UM12	111.INB5	2.0 NM	5
R/L .IK.UHCM.1212.6	12	12	90	73	20	21	3	-2		UM16	111.INB5	2.0 NM	6
R/L .IK.UHCM.1212.7	12	12	90	73	20	21	3	-2		UM16	111.INB5	2.0 NM	7
R/L .IK.UHCM.1616.4	16	16	130	113	20	22				UM12	111.INB5	2.0 NM	4
R/L .IK.UHCM.1616.5	16	16	130	113	20	22				UM12	111.INB5	2.0 NM	5
R/L .IK.UHCM.1616.6	16	16	130	113	20	22		-2		UM16	111.INB5	2.0 NM	6
R/L .IK.UHCM.1616.7	16	16	130	113	20	22		-2		UM16	111.INB5	2.0 NM	7

Kühlmittldruck max. 10 bar

Bestellbeispiel:
R.IK.UHCM.1212.4

Coolant pressure max. 10 bar

order-example:
R.IK.UHCM.1212.4

ULTRAMINI

Bohrungsbearbeitung
ab Ø 0.2 mm

grooving, boring and profiling
starting at Ø 0.2 mm

Typ .UM.18 / .UM.28

Klemmhalter,
Quadratschaft,
mit Innenkühlung

toolholder,
square shank,
with internal cooling

10.0 x 10.0 mm
für Schneideinsätze
D min. 0.2 - 7.0 mm

10.0 x 10.0 mm
for insert
D min. 0.2 - 7.0 mm

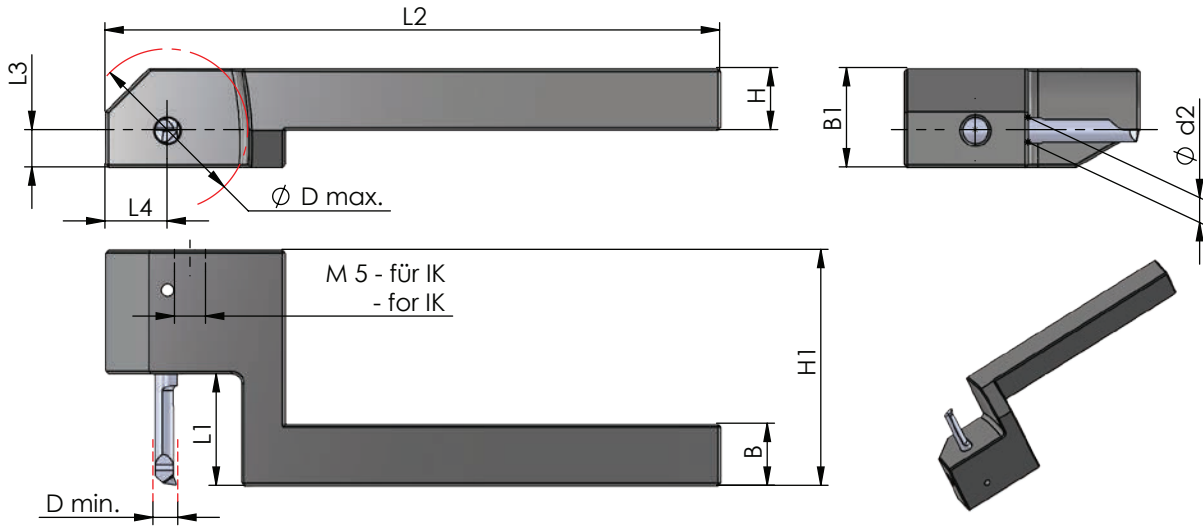

Rechts (R): wie gezeichnet
Links (L): spiegelbildlich

Rechte Schneidpl. in rechte Halter
Linke Schneidpl. in linkem Halter

Abmessungen in mm

righthand version (R): as shown
lefthand version (L): mirror image

use RH insert in RH tool holder and
LH insert in LH tool holder

dimensions in mm

Bestellnummer part number	H	B	L2	L1	L3	L4	H1	B1	Ø D max.	Spannschraube screw	Schraubenschlüssel wrench	Anzugs- drehmoment torque	Ø d2 Ø d h6 Schneideinsatz insert
R/L .UM.18.1010.4	10	10	99	18	6	10	38	16	26	110.650	111.645	1.2 Nm	4
R/L .UM.18.1010.5	10	10	99	18	6	10	38	16	26	110.650	111.645	1.2 Nm	5
R/L .UM.18.1010.6	10	10	99	18	6	10	38	16	26	110.650	111.645	1.2 Nm	6
R/L .UM.18.1010.7	10	10	99	18	6	10	38	16	26	110.650	111.645	1.2 Nm	7
R/L .UM.28.1010.4	10	10	99	28	6	10	48	16	26	110.650	111.645	1.2 Nm	4
R/L .UM.28.1010.5	10	10	99	28	6	10	48	16	26	110.650	111.645	1.2 Nm	5
R/L .UM.28.1010.6	10	10	99	28	6	10	48	16	26	110.650	111.645	1.2 Nm	6
R/L .UM.28.1010.7	10	10	99	28	6	10	48	16	26	110.650	111.645	1.2 Nm	7

Bestellbeispiel:
für rechte Ausführung
R.UM.18.1010.4

order-example:
righthand version
R.UM.18.1010.4

ULTRAMINI

Bohrungsbearbeitung
ab $\varnothing 0.2$ mm

grooving, boring and profiling
starting at $\varnothing 0.2$ mm

Typ .UM.18 / .UM.28

Klemmhalter,
Quadratschaft,
mit Innenkühlung

toolholder,
square shank,
with internal cooling

12.0 x 12.0 mm
für Schneideinsätze
D min. 0.2 - 7.0 mm

12.0 x 12.0 mm
for insert
D min. 0.2 - 7.0 mm

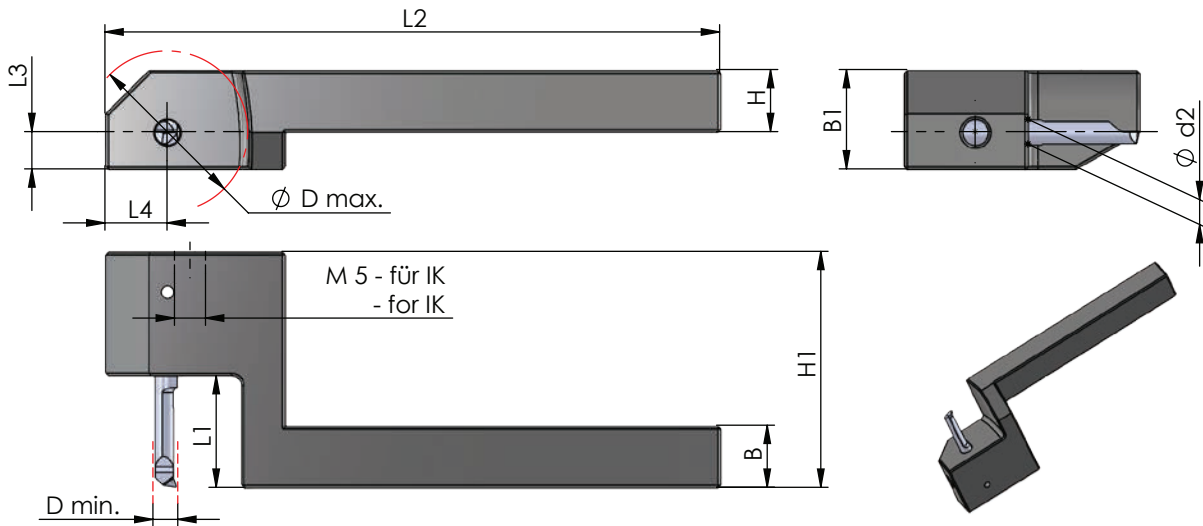

Rechts (R): wie gezeichnet
Links (L): spiegelbildlich

Rechte Schneidpl. in rechte Halter
Linke Schneidpl. in linkem Halter

Abmessungen in mm

righthand version (R): as shown
lefthand version (L): mirror image

use RH insert in RH tool holder and
LH insert in LH tool holder

dimensions in mm

Bestellnummer part number	H	B	L2	L1	L3	L4	H1	B1	Ø D max.	Spannschraube screw	Schraubenschlüssel wrench	Anzugs- drehmoment torque	Schneideinsatz insert	
													Ø d2	Ø d h6
R/L .UM.18.1212.4	12	12	99	18	6	10	38	18	26	110.650	111.645	1.2 Nm	4	
R/L .UM.18.1212.5	12	12	99	18	6	10	38	18	26	110.650	111.645	1.2 Nm	5	
R/L .UM.18.1212.6	12	12	99	18	6	10	38	18	26	110.650	111.645	1.2 Nm	6	
R/L .UM.18.1212.7	12	12	99	18	6	10	38	18	26	110.650	111.645	1.2 Nm	7	
R/L .UM.28.1212.4	12	12	99	28	6	10	48	18	26	110.650	111.645	1.2 Nm	4	
R/L .UM.28.1212.5	12	12	99	28	6	10	48	18	26	110.650	111.645	1.2 Nm	5	
R/L .UM.28.1212.6	12	12	99	28	6	10	48	18	26	110.650	111.645	1.2 Nm	6	
R/L .UM.28.1212.7	12	12	99	28	6	10	48	18	26	110.650	111.645	1.2 Nm	7	

Bestellbeispiel:
für rechte Ausführung
R.UM.18.1212.4

order-example:
righthand version
R.UM.18.1212.4

ULTRAMINI

Bohrungsbearbeitung
ab $\varnothing 0.2$ mm

grooving, boring and profiling
starting at $\varnothing 0.2$ mm

Typ TD0710

Klemmhalter,
Rechteckschaft
für Tornos DECO 7/10

toolholder,
rectangle shank
for Tornos DECO 7/10

für Schneideinsätze
D min. 0.2 - 7.0 mm

for insert
D min. 0.2 - 7.0 mm

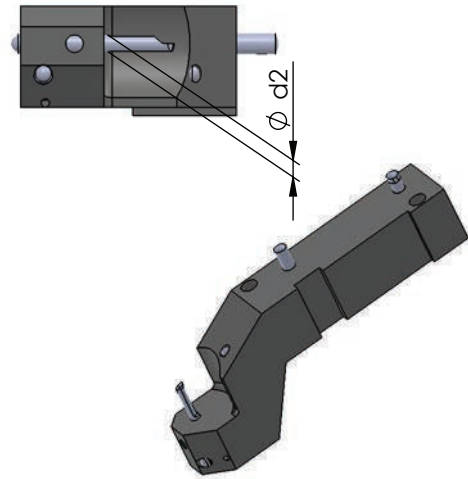
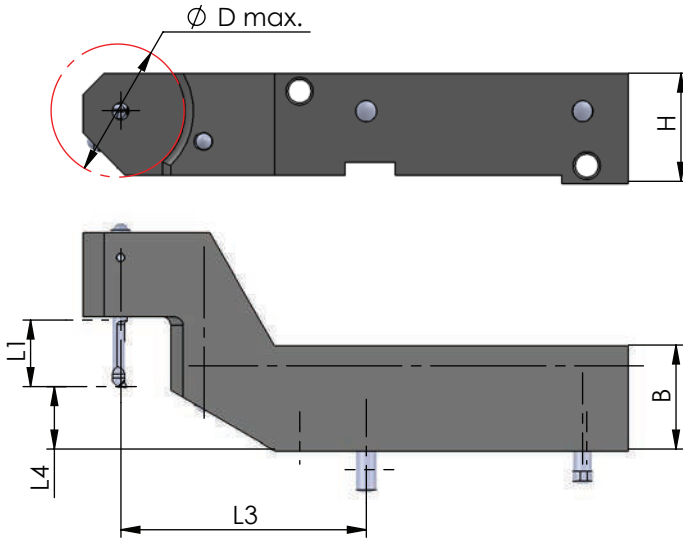

Rechts (R): wie gezeichnet
Links (L): spiegelbildlich

Rechte Schneidpl. in rechte Halter
Linke Schneidpl. in linkem Halter

Abmessungen in mm

righthand version (R): as shown
lefthand version (L): mirror image

use RH insert in RH tool holder and
LH insert in LH tool holder

dimensions in mm

Bestellnummer part number	H	B	L1	L3	L4	Ø D max.	Spannschraube screw	Schraubenschlüssel wrench	Anzugs- drehmoment torque	Ø d2
										Ø d h6 Schneideinsatz insert
R/L .TD0710.16.4	26	25	16	59	15	32	G016	111.645	1.2 Nm	4
R/L .TD0710.16.5	26	25	16	59	15	32	G016	111.645	1.2 Nm	5
R/L .TD0710.16.6	26	25	16	59	15	32	G016	111.645	1.2 Nm	6
R/L .TD0710.16.7	26	25	16	59	15	32	G016	111.645	1.2 Nm	7

Bestellbeispiel:
für rechte Ausführung
R.TD0710.16.4

order-example:
righthand version
R.TD0710.16.4

ULTRAMINI

Bohrungsbearbeitung
ab $\varnothing 0.2 \text{ mm}$

grooving, boring and profiling
starting at $\varnothing 0.2 \text{ mm}$

Typ UMHV

Höhenverstellbarer Klemmhalter und
Reduzierhülse für Rückseiten-
bearbeitung auf Langdrehautomaten

height adjustable toolholder and
reduction bush for rear end machining
on Swiss type lathes

ab $\varnothing 4 - 10 \text{ mm}$
für Schneideinsatz
ab $D \text{ min. } 0.2 \text{ mm}$

starting at $\varnothing 4 - 10 \text{ mm}$
for insert starting at
 $D \text{ min. } 0.2 \text{ mm}$

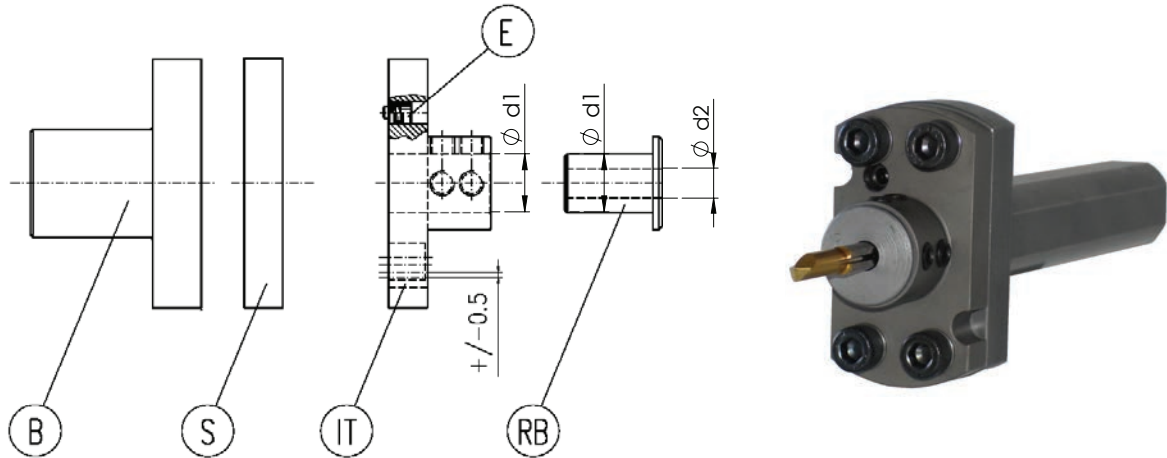

Abmessungen in mm

dimensions in mm

Bestellnummer part number	Position	Bezeichnung description	Abmessungen		$\varnothing d1 / \varnothing d2$ $\varnothing d1 \ll \varnothing d h6$ Schneideinsatz insert
			$\varnothing d1$	$\varnothing d2$	
UMHV-IT020110	IT	Klemmhalter Innendrehen / toolholder internal turning	10		10
UMHV-IT050110	IT		10		10
UMHV-IT90F0110	IT		10		10
UMHV-RBD1004	RB	Reduzierhülse / reduction bush		4	4
UMHV-RBD1005	RB			5	5
UMHV-RBD1006	RB			6	6
UMHV-RBD1007	RB			7	7
UMHV-RBD1008	RB			8	8
auf Anfrage / on request	B	Grundhalter / basic toolholder			
auf Anfrage / on request	S	Zwischenplatte / spacer			
auf Anfrage / on request	E	Excenter / excenter			

Bestellbeispiel:
UMHV-IT020110

order-example:
UMHV-IT020110

ULTRAMINI

Bohrungsbearbeitung
ab \varnothing 0.2 mm

grooving, boring and profiling
starting at \varnothing 0.2 mm

Impressionen

impressions

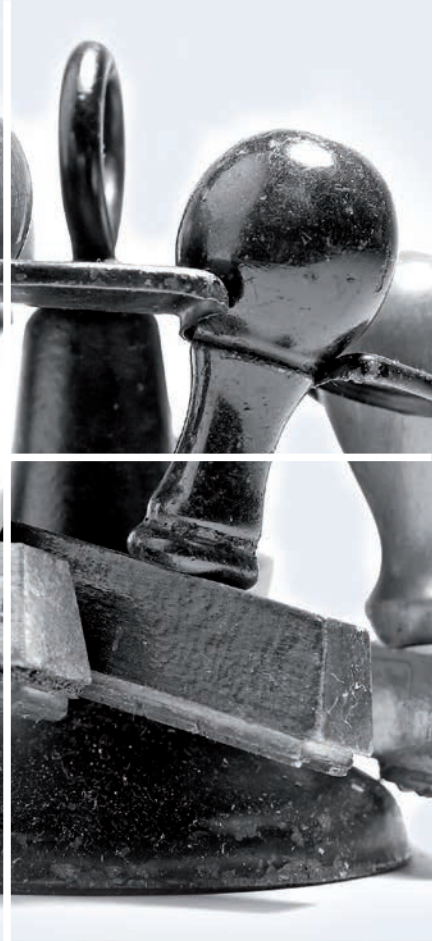

ULTRAMINI

Bohrungsbearbeitung
ab Ø 0.2 mm

grooving, boring and profiling
starting at Ø 0.2 mm

Typ 050

Audreihen und Kopieren

D min. 0.2 - 9.8 mm

boring and profiling

D min. 0.2 - 9.8 mm

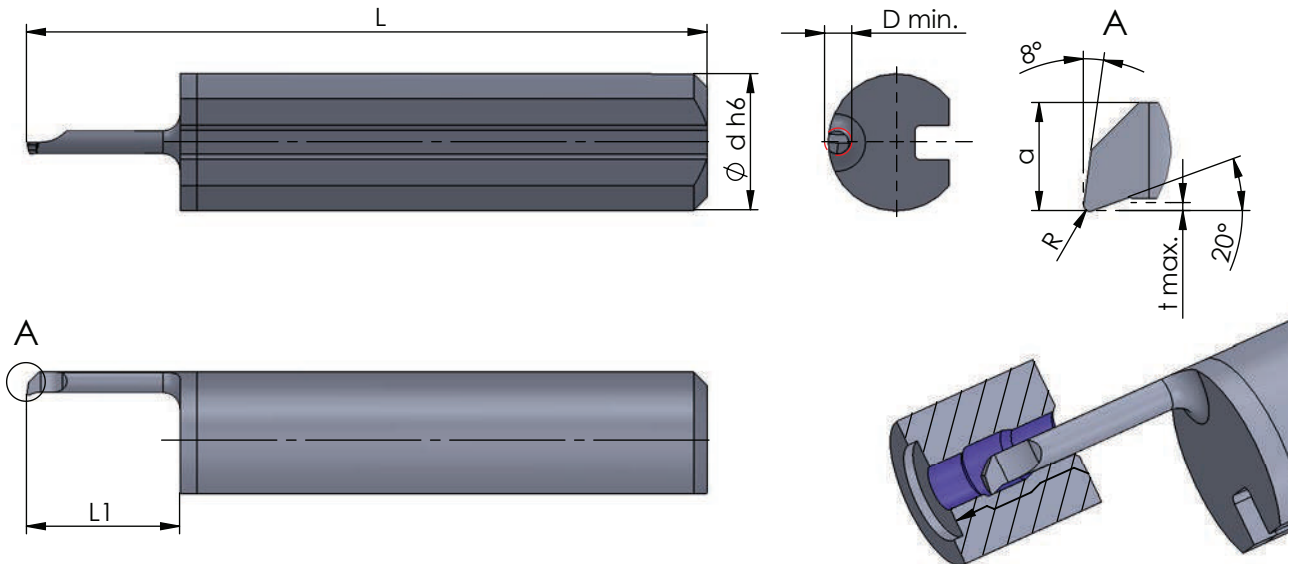

Rechts (R): wie gezeichnet
Links (L): spiegelbildlich

*zentrisch aufgebaut

Abmessungen in mm

righthand (R): as shown
lefthand version (L): mirror image

* central designed

dimensions in mm

Bestellnummer part number	R	f	a	L	L1	t max.	D min.	Ø d h6	K10F CN45F AL41F PD2F	Klemmhalter Typ	toolholder type
										640... 645... ...4	
R/L 050.02-1 *	0.02		0.15	20	1.0	-	0.2	4.0	●		
R/L 050.05-2	0.04		0.4	20	2.0	-	0.5	4.0	● ●		
R/L 050.06-2	0.04		0.5	20	2.0	0.05	0.6	4.0	● ●		
R/L 050.06-3	0.04		0.5	20	3.0	0.05	0.6	4.0	● ●		
R/L 050.08-4	0.04		0.7	20	4.0	0.05	0.8	4.0	● ●		
R/L 050.1-5	0.05		0.9	20	4.5	0.1	1.0	4.0	● ●		
R/L 050.1-7	0.05		0.9	22	6.5	0.1	1.0	4.0	● ●		
R/L 050.1-8	0.05		0.9	22	8.0	0.1	1.0	4.0	● ●		
R/L 050.15-5	0.05		1.3	19	5.0	0.1	1.5	4.0	● ●		
R/L 050.15-10	0.05		1.3	24	10.0	0.1	1.5	4.0	● ●		
R/L 050.15-12	0.05		1.3	26	12.0	0.1	1.5	4.0	●		
R/L 050.2-5	0.05		1.7	19	5.0	0.1	2.0	4.0	● ● ●		
R/L 050.2-10	0.05		1.7	24	10.0	0.1	2.0	4.0	● ● ●		
R/L 050.2-15	0.05		1.7	29	15.0	0.1	2.0	4.0	● ● ●		
↳ ...											

Weitere HM Sorten können Sie in der Sortenübersicht im Kapitel "Technische Hinweise" und der Preisliste finden.

Bestellbeispiel:
für rechte Ausführung und Sorte
R050.02-1/K10F

More carbide grades you can find in the grades summary in the chapter "technical instructions" and in the price list.

order-example:
righthand version and grade
R050.02-1/K10F

ULTRAMINI

Bohrungsbearbeitung
ab $\varnothing 0.2$ mm

grooving, boring and profiling
starting at $\varnothing 0.2$ mm

Typ 050

Audreihen und Kopieren

D min. 0.2 - 9.8 mm

boring and profiling

D min. 0.2 - 9.8 mm

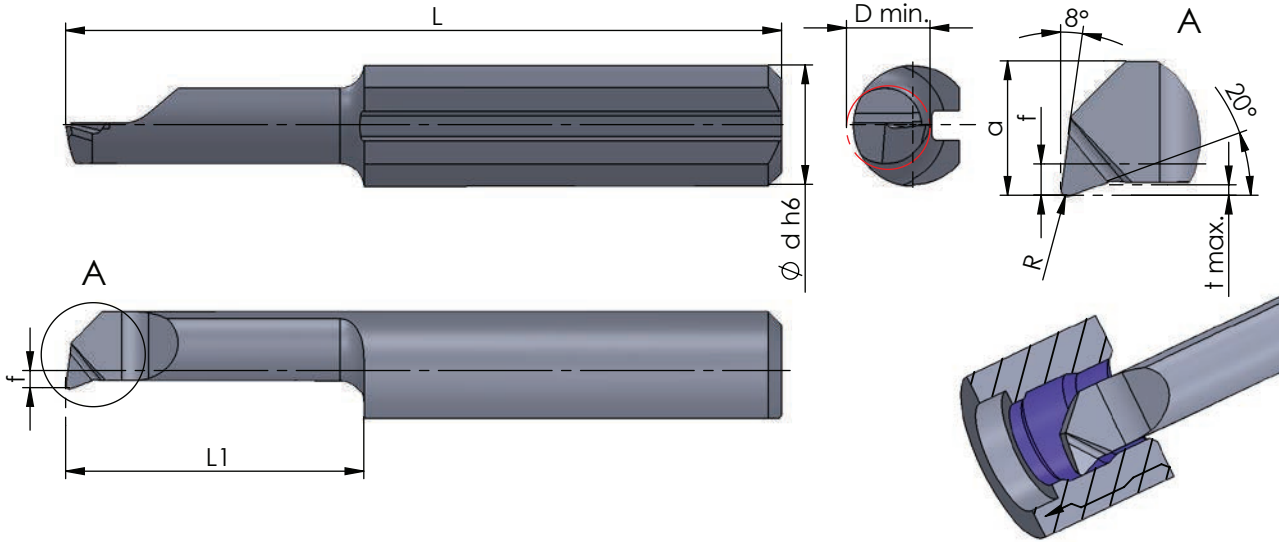

Rechts (R): wie gezeichnet
Links (L): spiegelbildlich

righthand (R): as shown
lefthand version (L): mirror image

Abmessungen in mm

dimensions in mm

Bestellnummer part number	R	f	a	L	L1	t max.	D min.	Ø d h6	K10F CN45F AL41F PD2F	Klemmhalter Typ	toolholder type
...											
R/L 050.25-5	0.05	0.2	2.2	19	5	0.15	2.5	4.0	● ● ●	640... 645... ...4	
R/L 050.25-10	0.05	0.2	2.2	24	10	0.15	2.5	4.0	● ● ●		
R/L 050.25-16	0.05	0.2	2.2	30	16	0.15	2.5	4.0	● ● ●		
R/L 050.3-10	0.1	0.6	2.6	24	10	0.2	2.8	4.0	● ● ●		
R/L 050.3-16	0.1	0.6	2.6	30	16	0.2	2.8	4.0	● ● ●		
R/L 050.3-20	0.1	0.6	2.6	34	20	0.2	2.8	4.0	● ● ●		
R/L 050.35-10	0.1	1.1	3.1	24	10	0.25	3.5	4.0	● ● ●		
R/L 050.35-16	0.1	1.1	3.1	30	16	0.25	3.5	4.0	● ● ●		
R/L 050.35-20	0.1	1.1	3.1	34	20	0.25	3.5	4.0	● ● ●		
R/L 050.35-24	0.1	1.1	3.1	38	24	0.25	3.5	4.0	● ●		
↳ ...											

Weitere HM Sorten können Sie in der Sortenübersicht im Kapitel "Technische Hinweise" und der Preisliste finden.

Bestellbeispiel:
für rechte Ausführung und Sorte
R050.25-5/AL41F

More carbide grades you can find in the grades summary in the chapter "technical instructions" and in the price list.

order-example:
righthand version and grade
R050.25-5/AL41F

ULTRAMINI

Bohrungsbearbeitung
ab $\varnothing 0.2$ mm

grooving, boring and profiling
starting at $\varnothing 0.2$ mm

Typ 050

Audreihen und Kopieren

D min. 0.2 - 9.8 mm

boring and profiling

D min. 0.2 - 9.8 mm

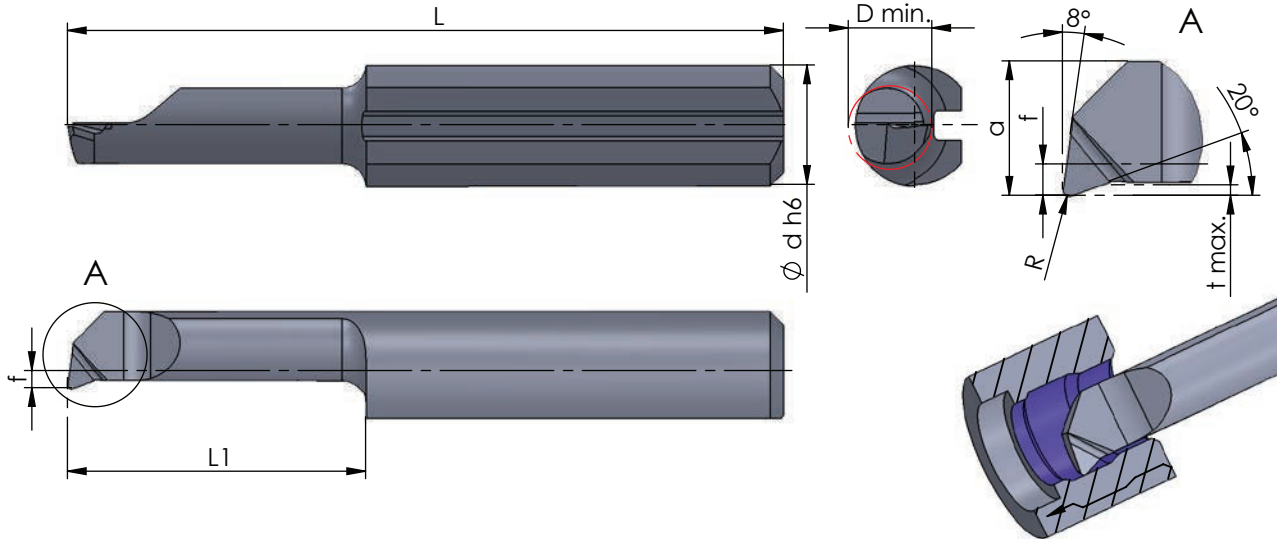

Rechts (R): wie gezeichnet
Links (L): spiegelbildlich

righthand (R): as shown
lefthand version (L): mirror image

Abmessungen in mm

dimensions in mm

Bestellnummer part number	R	f	a	L	L1	t max.	D min.	Ø d h6	K10F CN45F AL41F PD2F	Klemmhalter Typ	toolholder type	
										645, ...	640,4 650,5	
⋮ ↴												
R/L 050.4-10	0.1	1.5	3.5	24	10	0.3	4.0	4.0	● ● ●	645, ...	640,4	
R/L 050.4-16	0.1	1.5	3.5	30	16	0.3	4.0	4.0	● ● ●			
R/L 050.4-20	0.1	1.5	3.5	34	20	0.3	4.0	4.0	● ● ●			
R/L 050.4-24	0.1	1.5	3.5	38	24	0.3	4.0	4.0	● ● ●			
R/L 050.4-28	0.1	1.5	3.5	42	28	0.3	4.0	4.0	● ●			
R/L 050.5-10	0.15	1.9	4.4	25	10	0.5	5.0	5.0	● ● ●	645, ...	650,5	
R/L 050.5-15	0.15	1.9	4.4	30	15	0.5	5.0	5.0	● ● ●			
R/L 050.5-20	0.15	1.9	4.4	35	20	0.5	5.0	5.0	● ● ●			
R/L 050.5-25	0.15	1.9	4.4	40	25	0.5	5.0	5.0	● ● ●			
R/L 050.5-30	0.15	1.9	4.4	45	30	0.5	5.0	5.0	● ● ●			
R/L 050.5-35	0.15	1.9	4.4	50	35	0.5	5.0	5.0	● ●			
R/L 050.5-40	0.15	1.9	4.4	55	40	0.5	5.0	5.0	● ●			
↳ ...												

Weitere HM Sorten können Sie in der Sortenübersicht im Kapitel "Technische Hinweise" und der Preisliste finden.

Bestellbeispiel:
für rechte Ausführung und Sorte
R050.4-10/AL41F

More carbide grades you can find in the grades summary in the chapter "technical instructions" and in the price list.

order-example:
righthand version and grade
R050.4-10/AL41F

ULTRAMINI

Bohrungsbearbeitung
ab \varnothing 0.2 mm

grooving, boring and profiling
starting at \varnothing 0.2 mm

Typ 050

Audreihen und Kopieren

D min. 0.2 - 9.8 mm

boring and profiling

D min. 0.2 - 9.8 mm

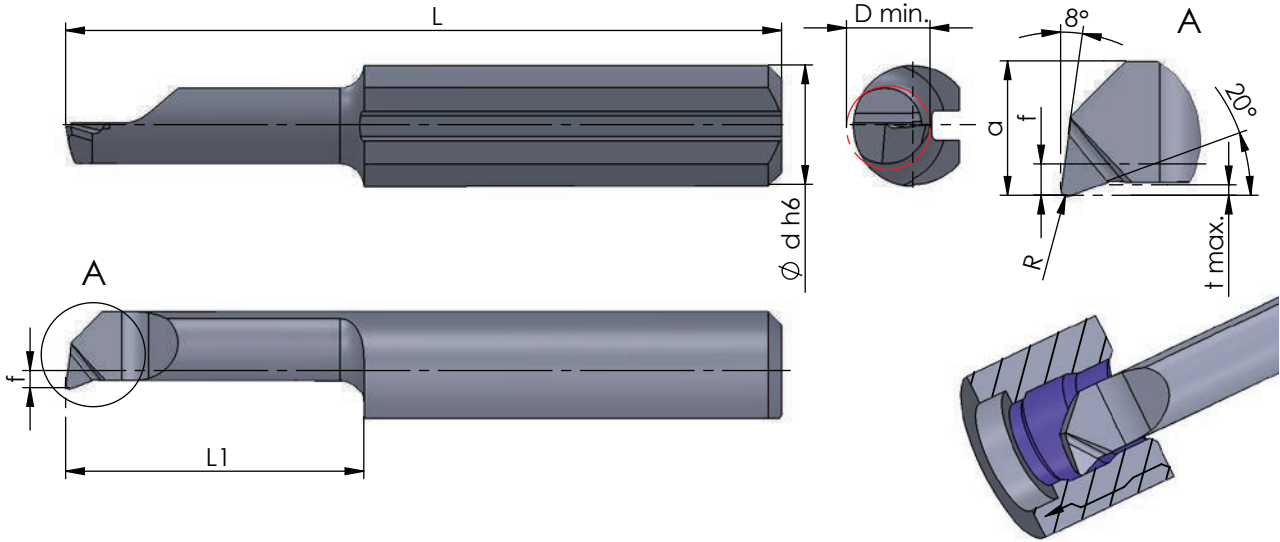

Rechts (R): wie gezeichnet
Links (L): spiegelbildlich

righthand (R): as shown
lefthand version (L): mirror image

Abmessungen in mm

dimensions in mm

Bestellnummer part number	R	f	a	L	L1	t max.	D min.	Ø d h6	K10F CN45F AL41F PD2F	Klemmhalter Typ toolholder type
R/L 050.6-15	0.15	2.3	5.3	30	15	0.5	6.0	6.0	● ● ●	676... 660... ...6
R/L 050.6-22	0.15	2.3	5.3	37	22	0.5	6.0	6.0	● ● ●	
R/L 050.6-25	0.15	2.3	5.3	40	25	0.5	6.0	6.0	● ● ●	
R/L 050.6-30	0.15	2.3	5.3	45	30	0.5	6.0	6.0	● ● ●	
R/L 050.6-35	0.15	2.3	5.3	50	35	0.5	6.0	6.0	● ● ●	
R/L 050.6-42	0.15	2.3	5.3	57	42	0.5	6.0	6.0	● ● ●	
R/L 050.7-20	0.15	2.8	6.3	35	20	0.6	6.8	7.0	● ● ●	676... 670... 687... ...7
R/L 050.7-25	0.15	2.8	6.3	40	25	0.6	6.8	7.0	● ● ●	
R/L 050.7-30	0.15	2.8	6.3	45	30	0.6	6.8	7.0	● ● ●	
R/L 050.7-35	0.15	2.8	6.3	50	35	0.6	6.8	7.0	● ● ●	
R/L 050.7-40	0.15	2.8	6.3	55	40	0.6	6.8	7.0	● ● ●	
R/L 050.7-45	0.15	2.8	6.3	60	45	0.6	6.8	7.0	● ● ●	
R/L 050.7-50	0.15	2.8	6.3	65	50	0.6	6.8	7.0	● ● ●	
↳ ...										

Weitere HM Sorten können Sie in der Sortenübersicht im Kapitel "Technische Hinweise" und der Preisliste finden.

Bestellbeispiel:
für rechte Ausführung und Sorte
R050.6-15/AL41F

More carbide grades you can find in the grades summary in the chapter "technical instructions" and in the price list.

order-example:
righthand version and grade
R050.6-15/AL41F

ULTRAMINI

Bohrungsbearbeitung
ab $\varnothing 0.2$ mm

grooving, boring and profiling
starting at $\varnothing 0.2$ mm

Typ 050

Audreihen und Kopieren

D min. 0.2 - 9.8 mm

boring and profiling

D min. 0.2 - 9.8 mm

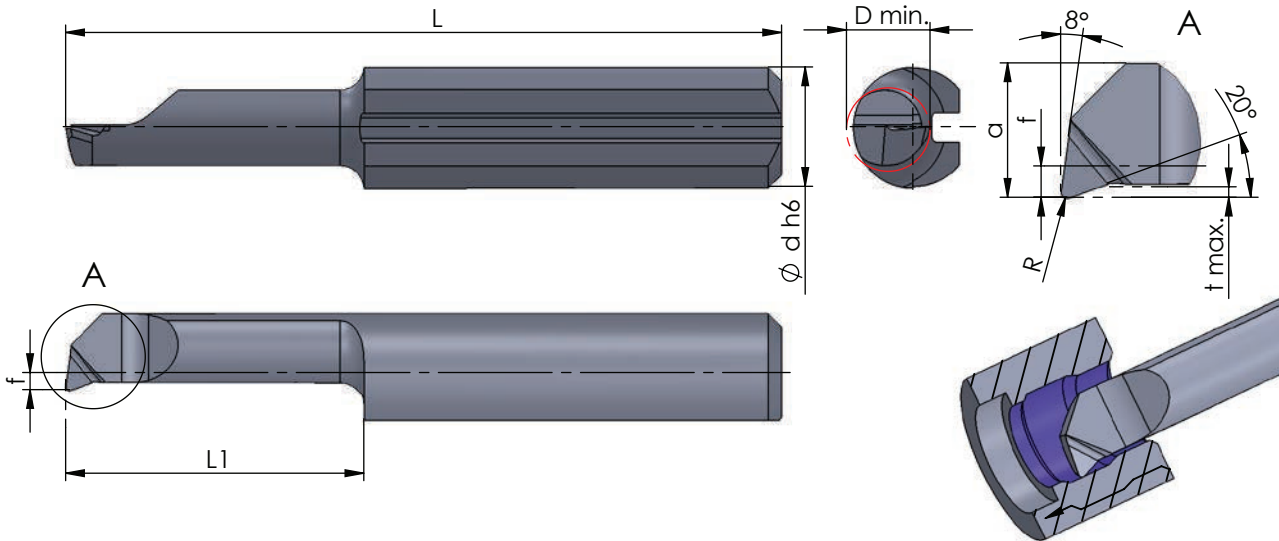

Rechts (R): wie gezeichnet
Links (L): spiegelbildlich

righthand (R): as shown
lefthand version (L): mirror image

Abmessungen in mm

dimensions in mm

Bestellnummer part number	R	f	a	L	L1	t max.	D min.	Ø d h6	Material				Klemmhalter Typ toolholder type
									K10F	CN45F	AL41F	PD2F	
...													
R/L 050.8-50	0.2	3.3	7.3	70	50	0.7	7.8	8.0			●		681... 680... 687... ...8
R/L 050.8-60	0.2	3.3	7.3	80	60	0.7	7.8	8.0			●		
R/L 050.10-35	0.2	4.2	9.2	60	35	1.0	9.8	10.0			●		

Weitere HM Sorten können Sie in der Sortenübersicht im Kapitel "Technische Hinweise" und der Preisliste finden.

Bestellbeispiel:
für rechte Ausführung und Sorte
R050.8-50/AL41F

More carbide grades you can find in the grades summary in the chapter "technical instructions" and in the price list.

order-example:
righthand version and grade
R050.8-50/AL41F

ULTRAMINI

Bohrungsbearbeitung
ab $\varnothing 0.2$ mm

grooving, boring and profiling
starting at $\varnothing 0.2$ mm

Superfinish Typ F050

Superfinish Ausdrehen für
perfekte Oberflächen

D min. 4.0 - 6.8 mm

Superfinish boring for
perfect surface quality

D min. 4.0 - 6.8 mm

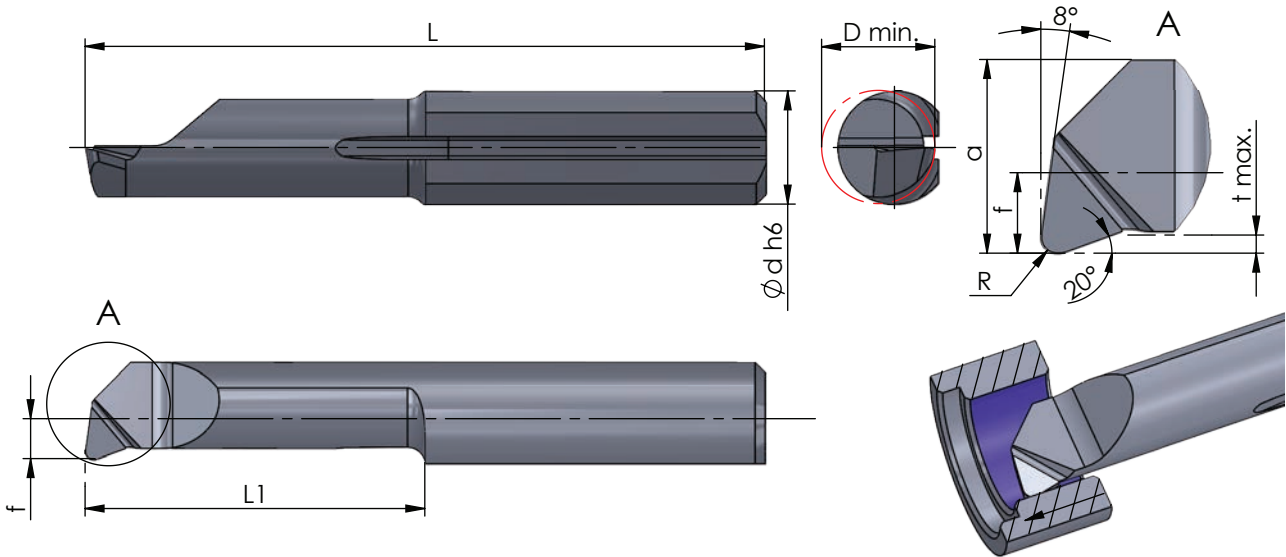

Rechts (R): wie gezeichnet
Links (L): spiegelbildlich

righthand (R): as shown
lefthand version (L): mirror image

Abmessungen in mm

dimensions in mm

	Bestellnummer part number	R	f	a	L	L1	t max.	D min.	Ø d h6	K10F	CN45F	AL41F	P18C-NH	Klemmhalter Typ	toolholder type
neu	R/L F050.4-10	0.4	1.35	3.35	24	10	0.25	4.0	4.0				●	645, ...	640,4
neu	R/L F050.4-20	0.4	1.35	3.35	34	20	0.25	4.0	4.0				●		
neu	R/L F050.5-15	0.4	1.80	4.30	30	15	0.40	5.0	5.0				●	645, ...	650,5
neu	R/L F050.5-25	0.4	1.80	4.30	40	25	0.40	5.0	5.0				●		
neu	R/L F050.6-15	0.4	2.20	5.20	30	15	0.50	6.0	6.0				●	676, ...	660,6
neu	R/L F050.6-30	0.4	2.20	5.20	45	30	0.50	6.0	6.0				●		
neu	R/L F050.7-20	0.4	2.70	6.20	35	20	0.50	7.0	6.8				●	676, ...	670, ... 687,7
neu	R/L F050.7-35	0.4	2.70	6.20	50	35	0.50	7.0	6.8				●		

Weitere HM Sorten können Sie in der Sortenübersicht im Kapitel "Technische Hinweise" und der Preisliste finden.

Bestellbeispiel:
für rechte Ausführung und Sorte
RF050.4-10/P18C-NH

weitere Informationen:

- siehe Allgemeine Beschreibung

more informations:

- look at the general instructions

More carbide grades you can find in the grades summary in the chapter "technical instructions" and in the price list.

order-example:
righthand version and grade
RF050.4-10/P18C-NH

ULTRAMINI

Bohrungsbearbeitung
ab $\varnothing 0.2$ mm

grooving, boring and profiling
starting at $\varnothing 0.2$ mm

Typ 050.20

Ausdrehen und Kopieren
mit Geometrie $20^\circ / 20^\circ$

boring and profiling
with geometry $20^\circ / 20^\circ$

D min. 2.0 - 5.0 mm

D min. 2.0 - 5.0 mm

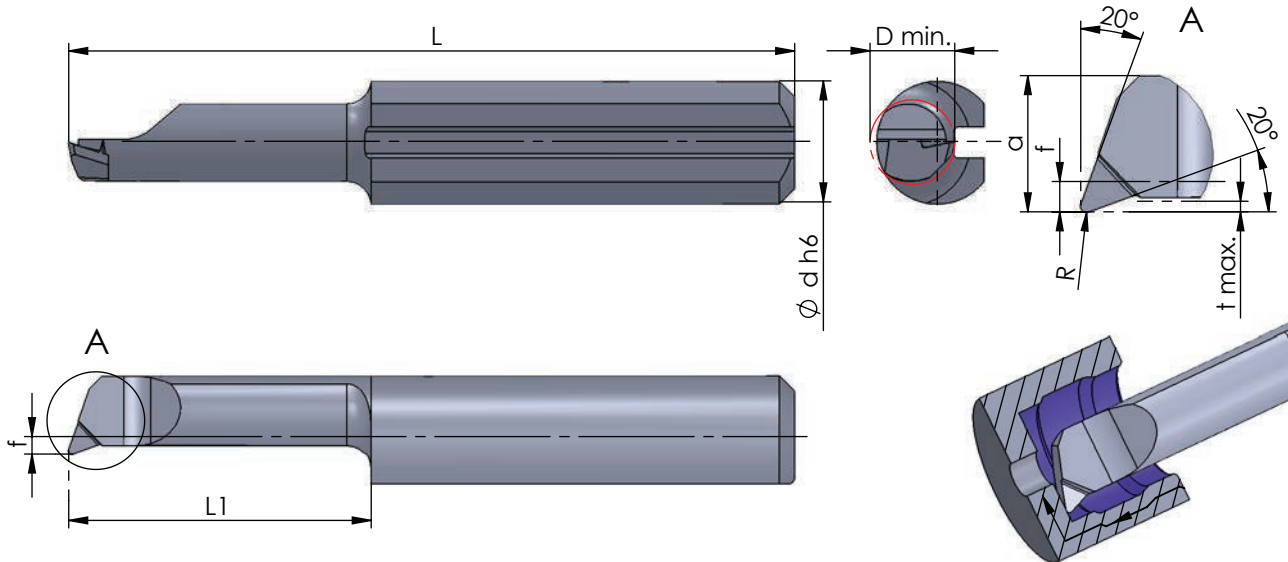

Rechts (R): wie gezeichnet
Links (L): spiegelbildlich

righthand (R): as shown
lefthand version (L): mirror image

Abmessungen in mm

dimensions in mm

Bestellnummer part number	R	f	a	L	L1	t max.	D min.	Ø d h6	K10F CN45F AL41F PD2F	Klemmhalter Typ toolholder type	
											645,...
R/L 050.20.2-5	0.05		1.7	19	5	0.1	2.0	4.0	●	645,...	640... ...4
R/L 050.20.2-10	0.05		1.7	24	10	0.1	2.0	4.0	●		
R/L 050.20.2-15	0.05		1.7	29	15	0.1	2.0	4.0	●		
R/L 050.20.3-10	0.1	0.6	2.6	24	10	0.2	2.8	4.0	●		
R/L 050.20.3-16	0.1	0.6	2.6	30	16	0.2	2.8	4.0	●		
R/L 050.20.3-20	0.1	0.6	2.6	34	20	0.2	2.8	4.0	●		
R/L 050.20.4-10	0.1	1.5	3.5	24	10	0.3	4.0	4.0	●		
R/L 050.20.4-16	0.1	1.5	3.5	30	16	0.3	4.0	4.0	●		
R/L 050.20.4-20	0.1	1.5	3.5	34	20	0.3	4.0	4.0	●		
R/L 050.20.4-24	0.1	1.5	3.5	38	24	0.3	4.0	4.0	●		
R/L 050.20.4-28	0.1	1.5	3.5	42	28	0.3	4.0	4.0	●		
R/L 050.20.5-10	0.15	1.9	4.4	25	10	0.5	5.0	5.0	●	650... ...5	
R/L 050.20.5-20	0.15	1.9	4.4	35	20	0.5	5.0	5.0	●		
R/L 050.20.5-35	0.15	1.9	4.4	50	35	0.5	5.0	5.0	●		

Weitere HM Sorten können Sie in der Sortenübersicht im Kapitel "Technische Hinweise" und der Preisliste finden.

Bestellbeispiel:
für rechte Ausführung und Sorte
R050.20.2-5/AL41F

More carbide grades you can find in the grades summary in the chapter "technical instructions" and in the price list.

order-example:
righthand version and grade
R050.20.2-5/AL41F

ULTRAMINI

Bohrungsbearbeitung
ab \varnothing 0.2 mm

grooving, boring and profiling
starting at \varnothing 0.2 mm

Typ 053

Audreihen und Kopieren
mit Eckenradius 0.03 mm

boring and profiling
with corner radius 0.03 mm

D min. 2.8 - 4.0 mm

D min. 2.8 - 4.0 mm

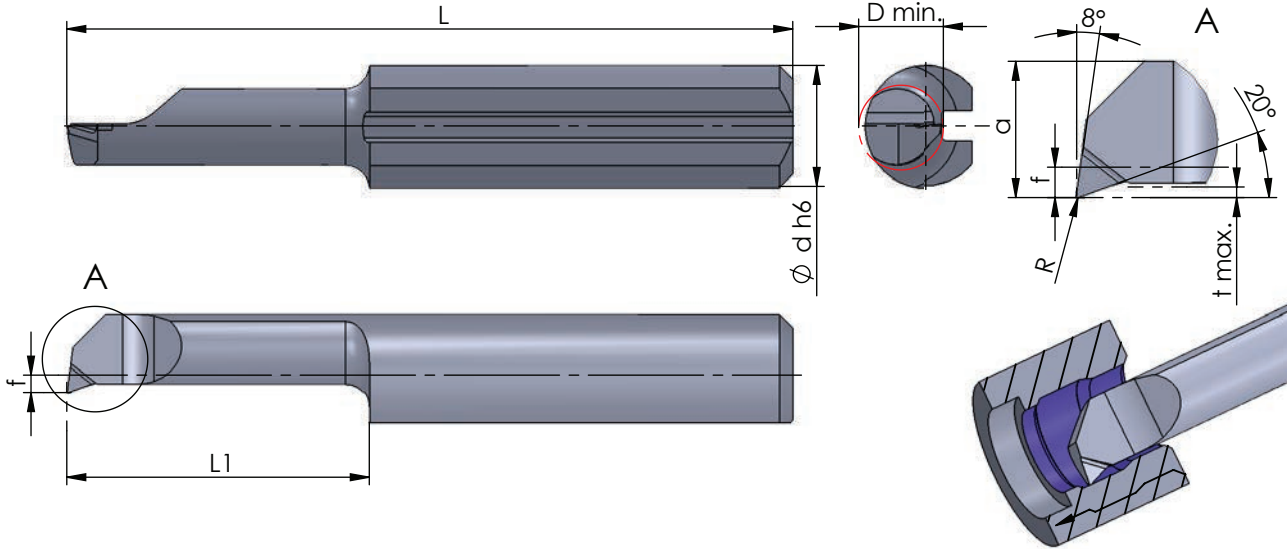

Rechts (R): wie gezeichnet
Links (L): spiegelbildlich

righthand (R): as shown
lefthand version (L): mirror image

Abmessungen in mm

dimensions in mm

Bestellnummer part number	R	f	a	L	L1	t max.	D min.	Ø d h6					Klemmhalter Typ toolholder type
									K10F	CN45F	AL41F	PD2F	
R/L 053.3-10	0.03	0.6	2.6	24	10	0.2	2.8	4.0			●		640... 645... ...4
R/L 053.3-16	0.03	0.6	2.6	30	16	0.2	2.8	4.0			●		
R/L 053.3-20	0.03	0.6	2.6	34	20	0.2	2.8	4.0			●		
R/L 053.4-10	0.03	1.5	3.5	24	10	0.3	4.0	4.0			●		
R/L 053.4-16	0.03	1.5	3.5	30	16	0.3	4.0	4.0			●		
R/L 053.4-20	0.03	1.5	3.5	34	20	0.3	4.0	4.0			●		
R/L 053.4-24	0.03	1.5	3.5	38	24	0.3	4.0	4.0			●		
R/L 053.4-28	0.03	1.5	3.5	42	28	0.3	4.0	4.0			●		

Weitere HM Sorten können Sie in der Sortenübersicht im Kapitel "Technische Hinweise" und der Preisliste finden.

Bestellbeispiel:
für rechte Ausführung und Sorte
R053.3-10/AL41F

More carbide grades you can find in the grades summary in the chapter "technical instructions" and in the price list.

order-example:
righthand version and grade
R053.3-10/AL41F

ULTRAMINI

Bohrungsbearbeitung
ab $\varnothing 0.2$ mm

grooving, boring and profiling
starting at $\varnothing 0.2$ mm

Typ 055

Ausdrehen und Kopieren
mit Eckenradius 0.05 mm

boring and profiling
with corner radius 0.05 mm

D min. 2.0 - 6.0 mm

D min. 2.0 - 6.0 mm

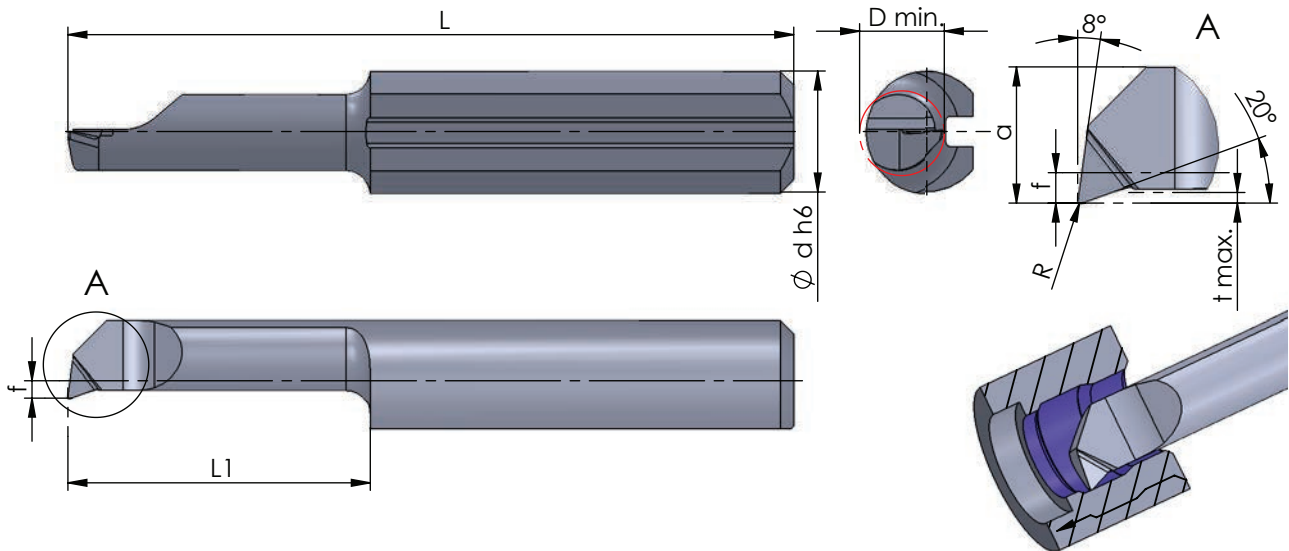

Rechts (R): wie gezeichnet
Links (L): spiegelbildlich

righthand (R): as shown
lefthand version (L): mirror image

Abmessungen in mm

dimensions in mm

Bestellnummer part number	R	f	a	L	L1	t max.	D min.	Ø d h6	Klemmhalter Typ toolholder type				
									K10F	CN45F	AL41F	PD2F	
R/L 055.2-5	0.05		1.7	19	5	0.1	2.0	4.0			●		640... 645... ...4
R/L 055.2-10	0.05		1.7	24	10	0.1	2.0	4.0			●		
R/L 055.2-15	0.05		1.7	29	15	0.1	2.0	4.0			●		
R/L 055.3-10	0.05	0.6	2.6	24	10	0.2	2.8	4.0			●		
R/L 055.3-16	0.05	0.6	2.6	30	16	0.2	2.8	4.0			●		
R/L 055.3-20	0.05	0.6	2.6	34	20	0.2	2.8	4.0			●		
R/L 055.4-10	0.05	1.5	3.5	24	10	0.3	4.0	4.0			●		
R/L 055.4-16	0.05	1.5	3.5	30	16	0.3	4.0	4.0			●		
R/L 055.4-20	0.05	1.5	3.5	34	20	0.3	4.0	4.0			●		
R/L 055.4-24	0.05	1.5	3.5	38	24	0.3	4.0	4.0			●		
R/L 055.4-28	0.05	1.5	3.5	42	28	0.3	4.0	4.0			●		
↳ ...													

Weitere HM Sorten können Sie in der Sortenübersicht im Kapitel "Technische Hinweise" und der Preisliste finden.

Bestellbeispiel:
für rechte Ausführung und Sorte
R055.2-5/AL41F

More carbide grades you can find in the grades summary in the chapter "technical instructions" and in the price list.

order-example:
righthand version and grade
R055.2-5/AL41F

ULTRAMINI

Bohrungsbearbeitung
ab $\varnothing 0.2$ mm

grooving, boring and profiling
starting at $\varnothing 0.2$ mm

Typ 055

Ausdrehen und Kopieren
mit Eckenradius 0.05 mm

boring and profiling
with corner radius 0.05 mm

D min. 2.0 - 6.0 mm

D min. 2.0 - 6.0 mm

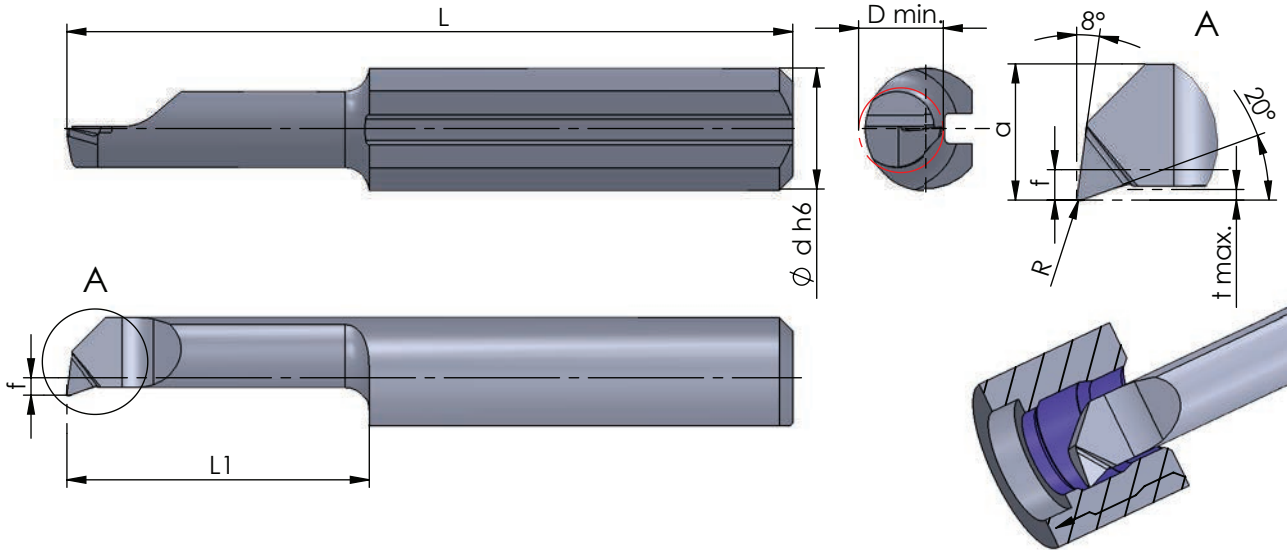

Rechts (R): wie gezeichnet
Links (L): spiegelbildlich

righthand (R): as shown
lefthand version (L): mirror image

Abmessungen in mm

dimensions in mm

Bestellnummer part number	R	f	a	L	L1	t max.	D min.	Ø d h6	K10F	CN45F	AL41F	PD2F	Klemmhalter Typ toolholder type
R/L 055.5-10	0.05	1.9	4.4	25	10	0.5	5.0	5.0			●		
R/L 055.5-15	0.05	1.9	4.4	30	15	0.5	5.0	5.0			●		
R/L 055.5-20	0.05	1.9	4.4	35	20	0.5	5.0	5.0			●		645... 650... ...5
R/L 055.5-25	0.05	1.9	4.4	40	25	0.5	5.0	5.0			●		
R/L 055.5-30	0.05	1.9	4.4	45	30	0.5	5.0	5.0			●		
R/L 055.5-35	0.05	1.9	4.4	50	35	0.5	5.0	5.0			●		
R/L 055.6-15	0.05	2.3	5.3	30	15	0.5	6.0	6.0			●		
R/L 055.6-22	0.05	2.3	5.3	37	22	0.5	6.0	6.0			●		
R/L 055.6-25	0.05	2.3	5.3	40	25	0.5	6.0	6.0			●		
R/L 055.6-30	0.05	2.3	5.3	45	30	0.5	6.0	6.0			●		
R/L 055.6-35	0.05	2.3	5.3	50	35	0.5	6.0	6.0			●		660... 676... ...6
R/L 055.6-42	0.05	2.3	5.3	57	42	0.5	6.0	6.0			●		

Weitere HM Sorten können Sie in der Sortenübersicht im Kapitel "Technische Hinweise" und der Preisliste finden.

Bestellbeispiel:
für rechte Ausführung und Sorte
R055.5-10/AL41F

More carbide grades you can find in the grades summary in the chapter "technical instructions" and in the price list.

order-example:
righthand version and grade
R055.5-10/AL41F

ULTRAMINI

Bohrungsbearbeitung
ab $\varnothing 0.2$ mm

grooving, boring and profiling
starting at $\varnothing 0.2$ mm

Typ 050....B

Ausdrehen und Kopieren
mit innerer Kühlmittelzufuhr

boring and profiling
with through coolant

D min. 6.0 - 6.8 mm
Auskrägung (L1) bis 7x D

D min. 6.0 - 6.8 mm
overhang length (L1) up to 7x D

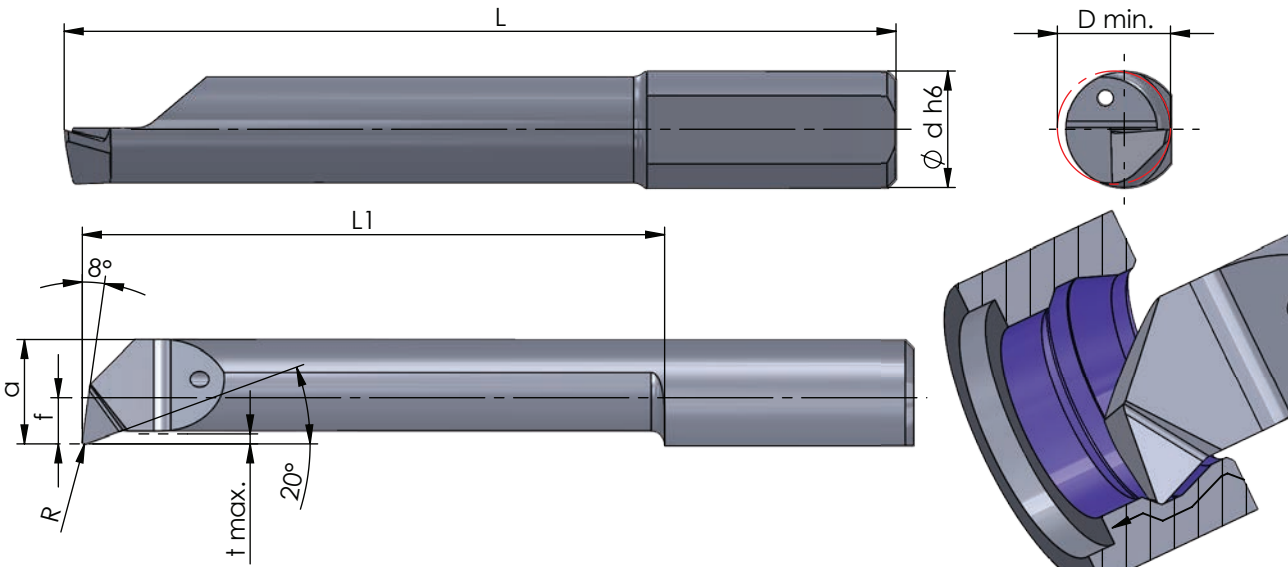

Rechts (R): wie gezeichnet
Links (L): spiegelbildlich

righthand (R): as shown
lefthand version (L): mirror image

Abmessungen in mm

dimensions in mm

Bestellnummer part number	R	f	a	L	L1	t max.	D min.	Ø d h6	Klemmhalter Typ				Klemmhalter Typ	toolholder type
									K10F	CN45F	AL41F	PD2F		
R/L 050.6-35B	0.15	2.3	5.3	50	35	0.5	6.0	6.0			●			
R/L 050.6-42B	0.15	2.3	5.3	57	42	0.5	6.0	6.0			●			660... ...6
R/L 050.7-35B	0.15	2.8	6.3	50	35	0.6	6.8	7.0			●	676...		
R/L 050.7-40B	0.15	2.8	6.3	55	40	0.6	6.8	7.0			●			
R/L 050.7-45B	0.15	2.8	6.3	60	45	0.6	6.8	7.0			●			670... 687... ...7
R/L 050.7-50B	0.15	2.8	6.3	65	50	0.6	6.8	7.0			●			

Weitere HM Sorten können Sie in der Sortenübersicht im Kapitel "Technische Hinweise" und der Preisliste finden.

Bestellbeispiel:
für rechte Ausführung und Sorte
R050.6-35B/AL41F

More carbide grades you can find in the grades summary in the chapter "technical instructions" and in the price list.

order-example:
righthand version and grade
R050.6-35B/AL41F

ULTRAMINI

Bohrungsbearbeitung
ab $\varnothing 0.2$ mm

grooving, boring and profiling
starting at $\varnothing 0.2$ mm

Typ 050....C

Ausdrehen und Kopieren
mit Spantreppe
für bessere Spantkontrolle

boring and profiling
with chipbreaker
for better chipcontrol

D min. 2.0 - 6.8 mm
Auskrägung (L1) bis 7x D

D min. 2.0 - 6.8 mm
overhang length (L1) up to 7x D

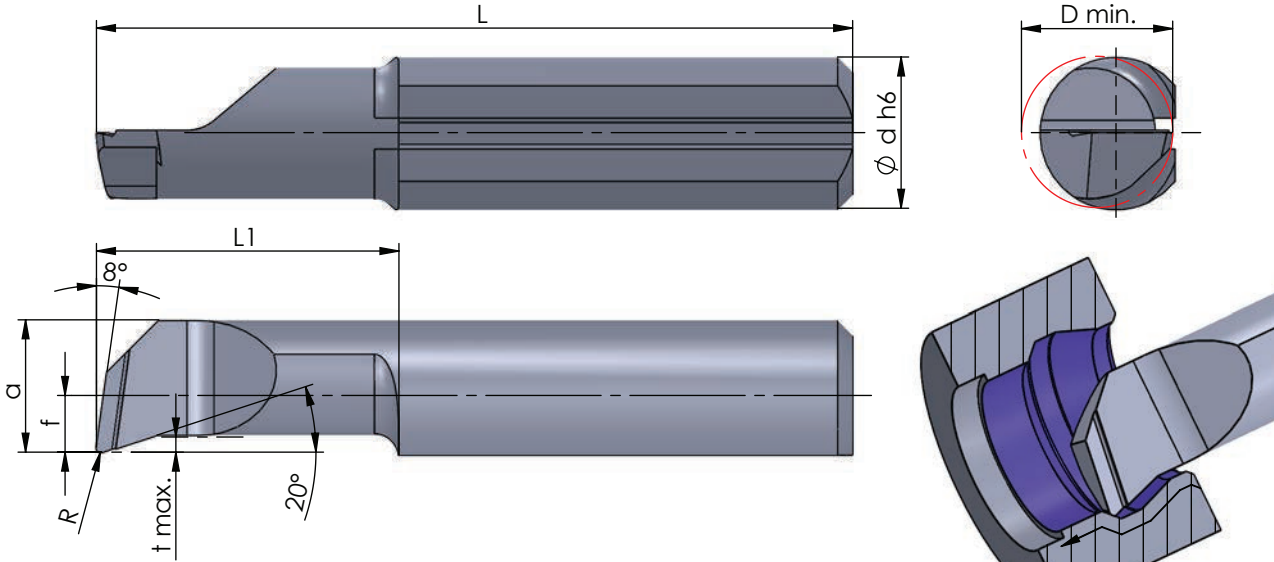

Rechts (R): wie gezeichnet
Links (L): spiegelbildlich

righthand (R): as shown
lefthand version (L): mirror image

Abmessungen in mm

dimensions in mm

Bestellnummer part number	R	f	a	L	L1	t max.	D min.	Ø d h6	K10F CN45F AL41F PD2F	Klemmhalter Typ toolholder type
R/L 050.2-10C	0.05		1.7	24	10	0.1	2.0	4.0	●	645... 640... ...4
R/L 050.3-10C	0.1	0.6	2.6	24	10	0.2	2.8	4.0	●	
R/L 050.3-16C	0.1	0.6	2.6	30	16	0.2	2.8	4.0	●	
R/L 050.4-10C	0.1	1.5	3.5	24	10	0.3	4.0	4.0	●	
R/L 050.4-16C	0.1	1.5	3.5	30	16	0.3	4.0	4.0	●	
R/L 050.4-20C	0.1	1.5	3.5	34	20	0.3	4.0	4.0	●	
R/L 050.4-24C	0.1	1.5	3.5	38	24	0.3	4.0	4.0	●	
R/L 050.4-28C	0.1	1.5	3.5	42	28	0.3	4.0	4.0	●	
R/L 050.5-10C	0.15	1.9	4.4	25	10	0.5	5.0	5.0	●	650... ...5
R/L 050.5-15C	0.15	1.9	4.4	30	15	0.5	5.0	5.0	● ●	
R/L 050.5-20C	0.15	1.9	4.4	35	20	0.5	5.0	5.0	●	
R/L 050.5-25C	0.15	1.9	4.4	40	25	0.5	5.0	5.0	●	
R/L 050.5-30C	0.15	1.9	4.4	45	30	0.5	5.0	5.0	●	
R/L 050.5-35C	0.15	1.9	4.4	50	35	0.5	5.0	5.0	●	
↳ ...										

Weitere HM Sorten können Sie in der Sortenübersicht im Kapitel "Technische Hinweise" und der Preisliste finden.

Bestellbeispiel:
für rechte Ausführung und Sorte
R050.2-10C/AL41F

More carbide grades you can find in the grades summary in the chapter "technical instructions" and in the price list.

order-example:
righthand version and grade
R050.2-10C/AL41F

ULTRAMINI

Bohrungsbearbeitung
ab \varnothing 0.2 mm

grooving, boring and profiling
starting at \varnothing 0.2 mm

Typ 050....C

Ausdrehen und Kopieren
mit Spantreppe
für bessere Spantkontrolle

boring and profiling
with chipbreaker
for better chipcontrol

D min. 2.0 - 6.8 mm
Auskrägung (L1) bis 7x D

D min. 2.0 - 6.8 mm
overhang length (L1) up to 7x D

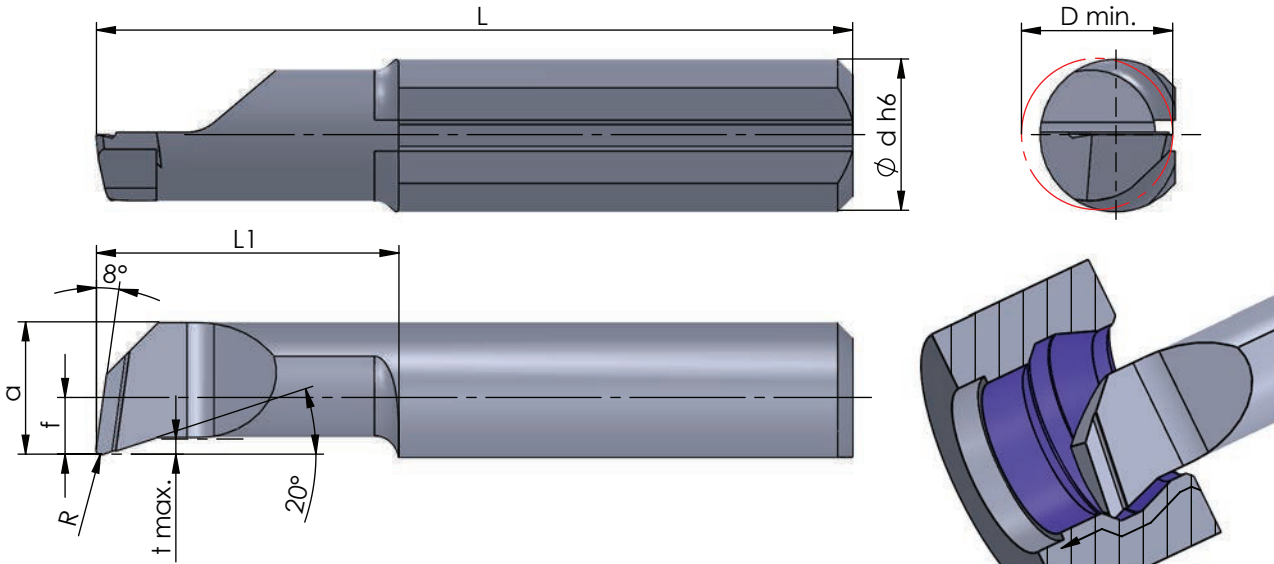

Rechts (R): wie gezeichnet
Links (L): spiegelbildlich

righthand (R): as shown
lefthand version (L): mirror image

Abmessungen in mm

dimensions in mm

Bestellnummer part number	R	f	a	L	L1	t max.	D min.	Ø d h6	Klemmhalter Typ toolholder type				
									K10F	CN45F	AL41F	PD2F	
...													
R/L 050.6-15C	0.15	2.3	5.3	30	15	0.5	6.0	6.0		●		676...	660... ...6
R/L 050.6-22C	0.15	2.3	5.3	37	22	0.5	6.0	6.0		●			
R/L 050.6-25C	0.15	2.3	5.3	40	25	0.5	6.0	6.0		●			
R/L 050.6-30C	0.15	2.3	5.3	45	30	0.5	6.0	6.0		●			
R/L 050.6-35C	0.15	2.3	5.3	50	35	0.5	6.0	6.0		●			
R/L 050.6-42C	0.15	2.3	5.3	57	42	0.5	6.0	6.0		●			
R/L 050.7-20C	0.15	2.8	6.3	35	20	0.6	6.8	7.0		●		676...	670... 687... ...7
R/L 050.7-25C	0.15	2.8	6.3	40	25	0.6	6.8	7.0		●			
R/L 050.7-30C	0.15	2.8	6.3	45	30	0.6	6.8	7.0		●			
R/L 050.7-35C	0.15	2.8	6.3	50	35	0.6	6.8	7.0		●			
R/L 050.7-40C	0.15	2.8	6.3	55	40	0.6	6.8	7.0		●			
R/L 050.7-45C	0.15	2.8	6.3	60	45	0.6	6.8	7.0		●			
R/L 050.7-50C	0.15	2.8	6.3	65	50	0.6	6.8	7.0		●			

Weitere HM Sorten können Sie in der Sortenübersicht im Kapitel "Technische Hinweise" und der Preisliste finden.

Bestellbeispiel:
für rechte Ausführung und Sorte
R050.6-15C/AL41F

More carbide grades you can find in the grades summary in the chapter "technical instructions" and in the price list.

order-example:
righthand version and grade
R050.6-15C/AL41F

ULTRAMINI

Bohrungsbearbeitung
ab $\varnothing 0.2$ mm

grooving, boring and profiling
starting at $\varnothing 0.2$ mm

Mediline Typ M050

Ausdrehen und Kopieren
mit innerer Kühlmittelzufuhr
und modifizierter Geometrie

boring and profiling
with through coolant
and modified profile

D min. 0.5 - 4.0 mm

D min. 0.5 - 4.0 mm

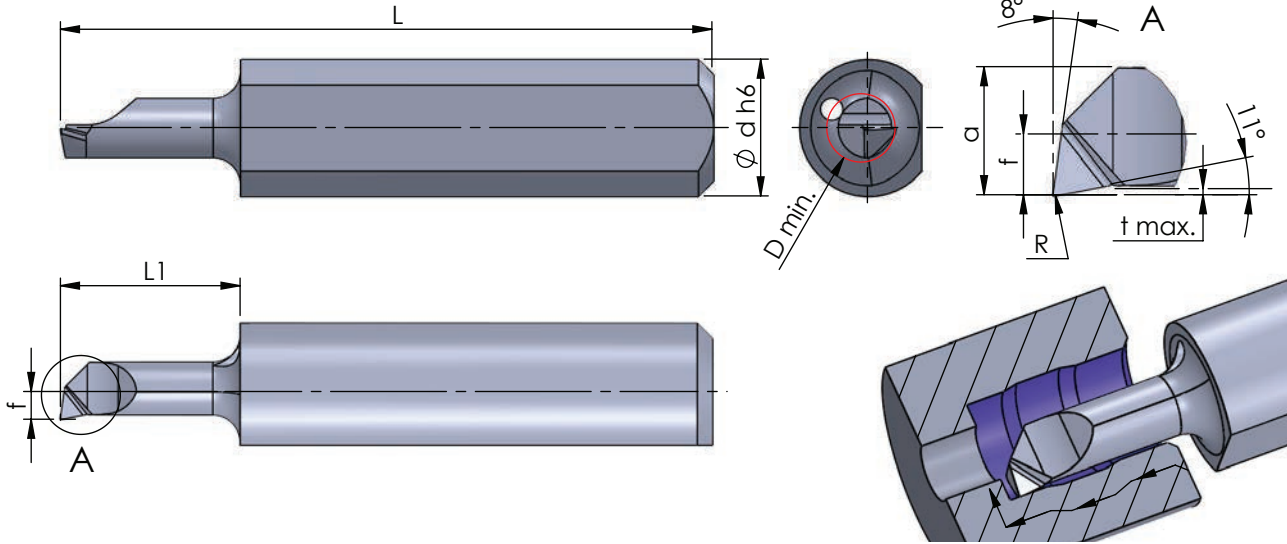

Rechts (R): wie gezeichnet
Links (L): spiegelbildlich

righthand (R): as shown
lefthand version (L): mirror image

Abmessungen in mm

dimensions in mm

Bestellnummer part number	R	f	a	L	L1	t max.	D min.	$\varnothing d h6$	K10F	CN45F	AL41F	P07C	Klemmhalter Typ	toolholder type
													640... 645... ...4	
R/L M050.05-2	0.02	0.2	0.4	20	2	0.02	0.5	4.0	●			●		
R/L M050.08-4	0.02	0.35	0.7	20	4	0.03	0.8	4.0	●			●		
R/L M050.1-5	0.02	0.4	0.9	20	5	0.05	1	4.0	●			●		
R/L M050.1-7	0.02	0.4	0.9	22	7	0.05	1	4.0	●			●		
R/L M050.15-5	0.02	0.6	1.35	19	5	0.08	1.5	4.0	●			●		
R/L M050.15-10	0.02	0.6	1.35	24	10	0.08	1.5	4.0	●			●		
R/L M050.2-5	0.02	0.8	1.7	19	5	0.08	2	4.0	●			●		
R/L M050.2-10	0.02	0.8	1.7	24	10	0.08	2	4.0	●			●		
↳ ...														

Weitere HM Sorten können Sie in der Sortenübersicht im Kapitel "Technische Hinweise" und der Preisliste finden.

Bestellbeispiel:
für rechte Ausführung und Sorte
RM050.05-2/P07C

weitere Informationen:

- siehe Allgemeine Beschreibung

more informations:

- look at the general instructions

More carbide grades you can find in the grades summary in the chapter "technical instructions" and in the price list.

order-example:
righthand version and grade
RM050.05-2/P07C

ULTRAMINI

Bohrungsbearbeitung
ab $\varnothing 0.2$ mm

grooving, boring and profiling
starting at $\varnothing 0.2$ mm

Mediline Typ M050

Audreihen und Kopieren
mit innerer Kühlmittelzufuhr
und modifizierter Geometrie

boring and profiling
with through coolant
and modified profile

D min. 0.5 - 4.0 mm

D min. 0.5 - 4.0 mm

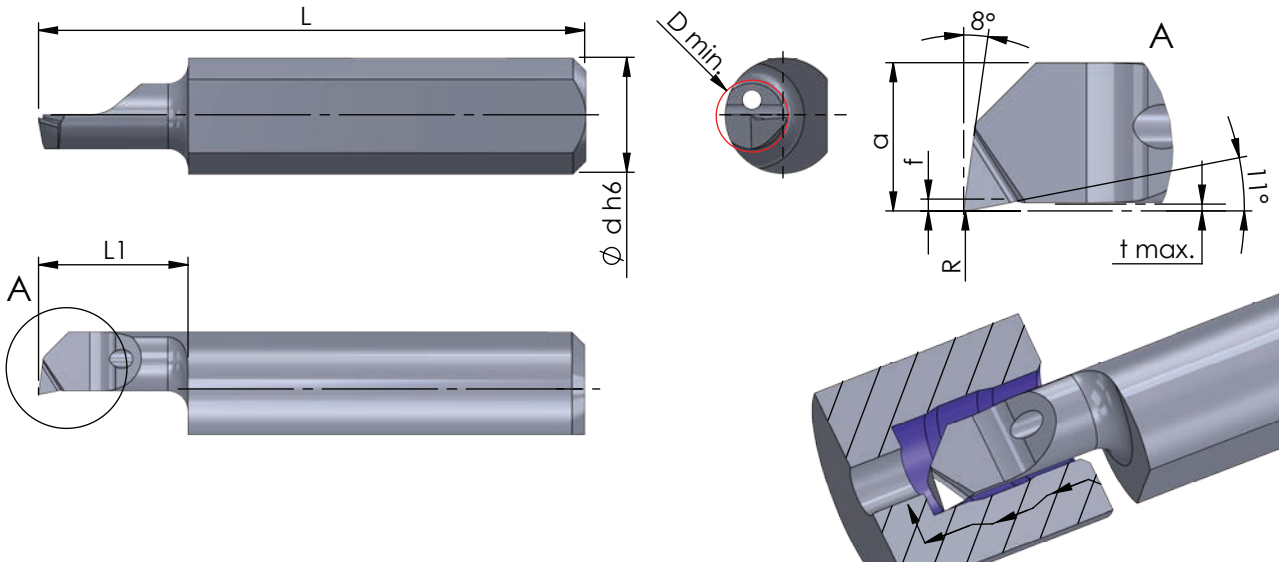

Rechts (R): wie gezeichnet
Links (L): spiegelbildlich

righthand (R): as shown
lefthand version (L): mirror image

Abmessungen in mm

dimensions in mm

Bestellnummer part number														Klemmhalter Typ toolholder type
	R	f	a	L	L1	t max.	D min.	\varnothing d h6	K10F	CN45F	AL41F	P07C		
...														
R/L M050.25-5	0.02	0.2	2.2	19	5	0.1	2.5	4.0	●			●	640... 645... ...4	
R/L M050.25-10	0.02	0.2	2.2	24	10	0.1	2.5	4.0	●			●		
R/L M050.3-10	0.02	0.6	2.6	24	10	0.15	3	4.0	●			●		
R/L M050.3-16	0.02	0.6	2.6	30	16	0.15	3	4.0	●			●		
R/L M050.35-10	0.02	1.1	3.1	24	10	0.17	3.5	4.0	●			●		
R/L M050.35-16	0.02	1.1	3.1	30	16	0.17	3.5	4.0	●			●		
R/L M050.35-20	0.02	1.1	3.1	34	20	0.17	3.5	4.0	●			●		
R/L M050.4-10	0.02	1.5	3.5	24	10	0.2	4	4.0	●			●		
R/L M050.4-16	0.02	1.5	3.5	30	16	0.2	4	4.0	●			●		
R/L M050.4-20	0.02	1.5	3.5	34	20	0.2	4	4.0	●			●		
R/L M050.4-24	0.02	1.5	3.5	38	24	0.2	4	4.0	●			●		

Weitere HM Sorten können Sie in der Sortenübersicht im Kapitel "Technische Hinweise" und der Preisliste finden.

Bestellbeispiel:
für rechte Ausführung und Sorte
RM050.25-5/P07C

weitere Informationen:
• siehe Allgemeine Beschreibung

more informations:
• look at the general instructions

More carbide grades you can find in the grades summary in the chapter "technical instructions" and in the price list.

order-example:
righthand version and grade
RM050.25-5/P07C

ULTRAMINI

Bohrungsbearbeitung
ab $\varnothing 0.2$ mm

grooving, boring and profiling
starting at $\varnothing 0.2$ mm

Xtraline Typ X050

Ausdrehen und Kopieren
mit innerer Kühlmittelzufuhr,
Spantreppe, extra stabile Ausführung

D min. 1.0 - 7.0 mm

boring and profiling
with through coolant,
chipbreaker and extra solid construction

D min. 1.0 - 7.0 mm

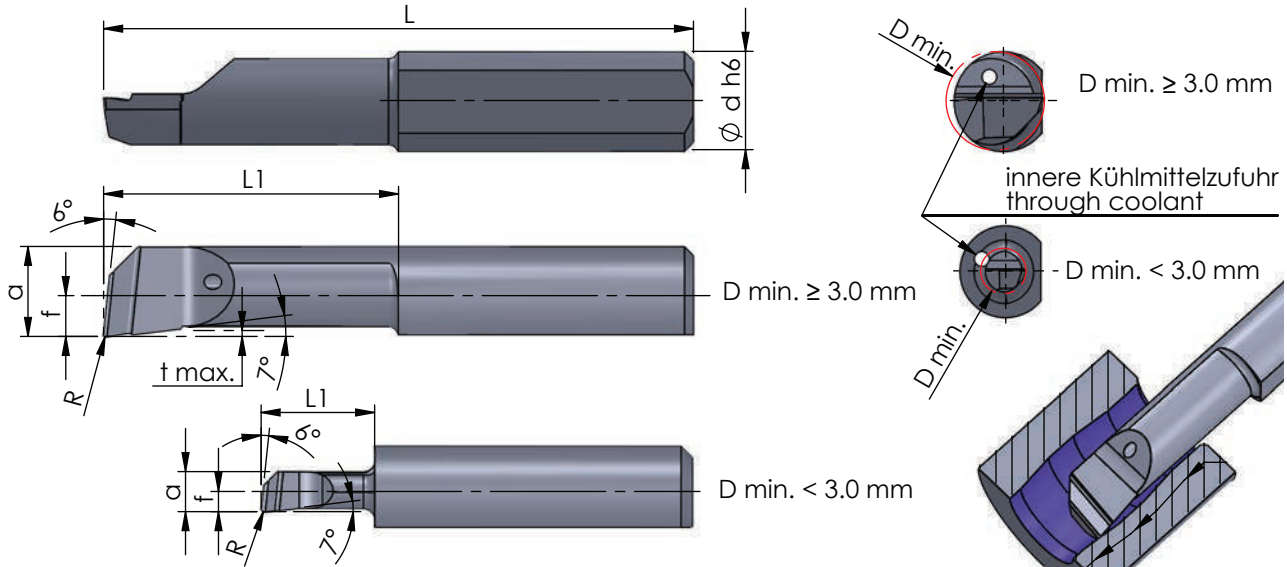

Rechts (R): wie gezeichnet
Links (L): spiegelbildlich

righthand (R): as shown
lefthand version (L): mirror image

Abmessungen in mm

dimensions in mm

Bestellnummer part number	R	f	a	L	L1	t max.	D min.	Ø d h6					Klemmhalter Typ toolholder type
									K10F	CN45F	AL41F	P18C	
R/L X050.1-5R05	0.05	0.45	0.9	20	5	0.03	1.0	4.0	●			●	640... 645... ...4
R/L X050.15-7R10	0.1	0.65	1.35	21	7	0.05	1.5	4.0	●			●	
R/L X050.2-5R15	0.15	0.9	1.8	19	5	0.1	2.0	4.0	●			●	
R/L X050.2-10R05	0.05	0.9	1.8	24	10	0.1	2.0	4.0	●			●	
R/L X050.2-10R15	0.15	0.9	1.8	24	10	0.1	2.0	4.0	●			●	
R/L X050.3-10R05	0.05	0.7	2.7	24	10	0.15	3.0	4.0	●			●	
R/L X050.3-10R20	0.2	0.7	2.7	24	10	0.15	3.0	4.0	●			●	
R/L X050.3-16R05	0.05	0.7	2.7	30	16	0.15	3.0	4.0	●			●	
R/L X050.3-16R10	0.1	0.7	2.7	30	16	0.15	3.0	4.0	●			●	
R/L X050.3-16R20	0.2	0.7	2.7	30	16	0.15	3.0	4.0	●			●	
↳ ...													

Weitere HM Sorten können Sie in der Sortenübersicht im Kapitel "Technische Hinweise" und der Preisliste finden.

Bestellbeispiel:
für rechte Ausführung und Sorte
RX050.1-5R05/P18C

weitere Informationen:
• siehe Allgemeine Beschreibung

more informations:
• look at the general instructions

More carbide grades you can find in the grades summary in the chapter "technical instructions" and in the price list.

order-example:
righthand version and grade
RX050.1-5R05/P18C

ULTRAMINI

Bohrungsbearbeitung
ab $\varnothing 0.2$ mm

grooving, boring and profiling
starting at $\varnothing 0.2$ mm

Xtraline Typ X050

Ausdrehen und Kopieren
mit innerer Kühlmittelzufuhr,
Spantreppe, extra stabile Ausführung

D min. 1.0 - 7.0 mm

boring and profiling
with through coolant,
chipbreaker and extra solid construction

D min. 1.0 - 7.0 mm

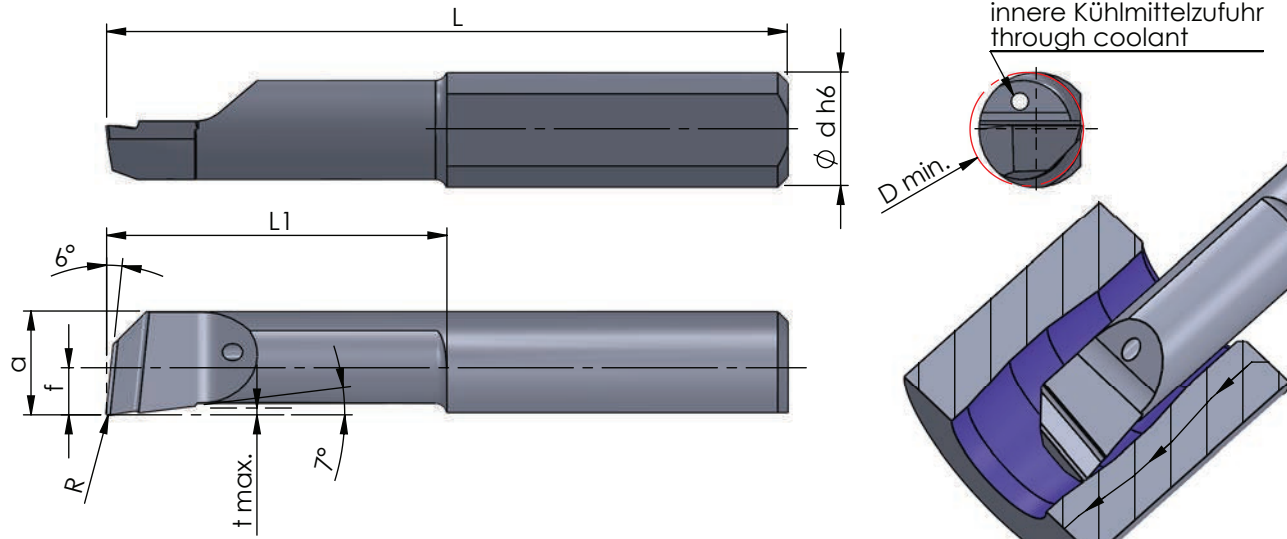

Rechts (R): wie gezeichnet
Links (L): spiegelbildlich

righthand (R): as shown
lefthand version (L): mirror image

Abmessungen in mm

dimensions in mm

Bestellnummer part number	R	f	a	L	L1	t max.	D min.	$\varnothing d h6$	Klemmhalter Typ toolholder type				
									K10F	CN45F	AL41F	P18C	
...													
R/L X050.4-10R10	0.1	1.6	3.6	24	10	0.2	4.0	4.0	●		●	645,...	640,4
R/L X050.4-10R20	0.2	1.6	3.6	24	10	0.2	4.0	4.0	●		●		
R/L X050.4-16R05	0.05	1.6	3.6	30	16	0.2	4.0	4.0	●		●		
R/L X050.4-16R10	0.1	1.6	3.6	30	16	0.2	4.0	4.0	●		●		
R/L X050.4-16R20	0.2	1.6	3.6	30	16	0.2	4.0	4.0	●		●		
R/L X050.4-16R40	0.4	1.6	3.6	30	16	0.2	4.0	4.0			●		
R/L X050.4-24R10	0.1	1.6	3.6	38	24	0.2	4.0	4.0	●		●		
R/L X050.4-24R20	0.2	1.6	3.6	38	24	0.2	4.0	4.0	●		●		
R/L X050.4-24R40	0.4	1.6	3.6	38	24	0.2	4.0	4.0			●		
...													

neu

neu

Weitere HM Sorten können Sie in der Sortenübersicht im Kapitel "Technische Hinweise" und der Preisliste finden.

Bestellbeispiel:
für rechte Ausführung und Sorte
RX050.4-10R10/P18C

weitere Informationen:
• siehe Allgemeine Beschreibung

more informations:
• look at the general instructions

More carbide grades you can find in the grades summary in the chapter "technical instructions" and in the price list.

order-example:
righthand version and grade
RX050.4-10R10/P18C

ULTRAMINI

Bohrungsbearbeitung
ab $\varnothing 0.2$ mm

grooving, boring and profiling
starting at $\varnothing 0.2$ mm

Xtraline Typ X050

Ausdrehen und Kopieren
mit innerer Kühlmittelzufuhr,
Spantreppe, extra stabile Ausführung

boring and profiling
with through coolant,
chipbreaker and extra solid construction

D min. 1.0 - 7.0 mm

D min. 1.0 - 7.0 mm

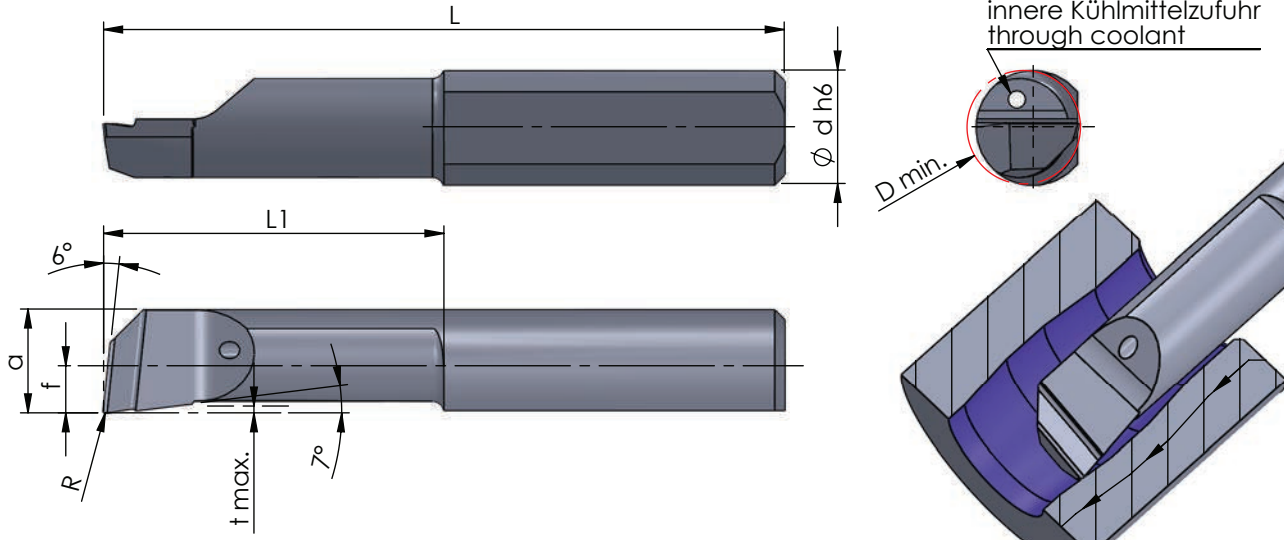

Rechts (R): wie gezeichnet
Links (L): spiegelbildlich

righthand (R): as shown
lefthand version (L): mirror image

Abmessungen in mm

dimensions in mm

Bestellnummer part number	R	f	a	L	L1	t max.	D min.	Ø d h6	K10F CN45F AL41F P18C	Klemmhalter Typ toolholder type
R/L X050.5-15R05	0.05	2.1	4.6	30	15	0.3	5.0	5.0	●	645, ... 650,5
R/L X050.5-15R10	0.1	2.1	4.6	30	15	0.3	5.0	5.0	●	
R/L X050.5-15R20	0.2	2.1	4.6	30	15	0.3	5.0	5.0	●	
R/L X050.5-15R40	0.4	2.1	4.6	30	15	0.3	5.0	5.0	●	
R/L X050.5-25R10	0.1	2.1	4.6	40	25	0.3	5.0	5.0	●	
R/L X050.5-25R20	0.2	2.1	4.6	40	25	0.3	5.0	5.0	●	
R/L X050.5-30R10	0.1	2.1	4.6	45	30	0.3	5.0	5.0	●	
R/L X050.5-30R20	0.2	2.1	4.6	45	30	0.3	5.0	5.0	●	
R/L X050.5-30R40	0.4	2.1	4.6	45	30	0.3	5.0	5.0	●	

Weitere HM Sorten können Sie in der Sortenübersicht im Kapitel "Technische Hinweise" und der Preisliste finden.

Bestellbeispiel:
für rechte Ausführung und Sorte
RX050.5-15R05/P18C

weitere Informationen:
• siehe Allgemeine Beschreibung

more informations:
• look at the general instructions

More carbide grades you can find in the grades summary in the chapter "technical instructions" and in the price list.

order-example:
righthand version and grade
RX050.5-15R05/P18C

ULTRAMINI

Bohrungsbearbeitung
ab Ø 0.2 mm

grooving, boring and profiling
starting at Ø 0.2 mm

Xtraline Typ X050

Ausdrehen und Kopieren
mit innerer Kühlmittelzufuhr,
Spantreppe, extra stabile Ausführung

boring and profiling
with through coolant,
chipbreaker
and extra solid construction

D min. 1.0 - 7.0 mm

D min. 1.0 - 7.0 mm

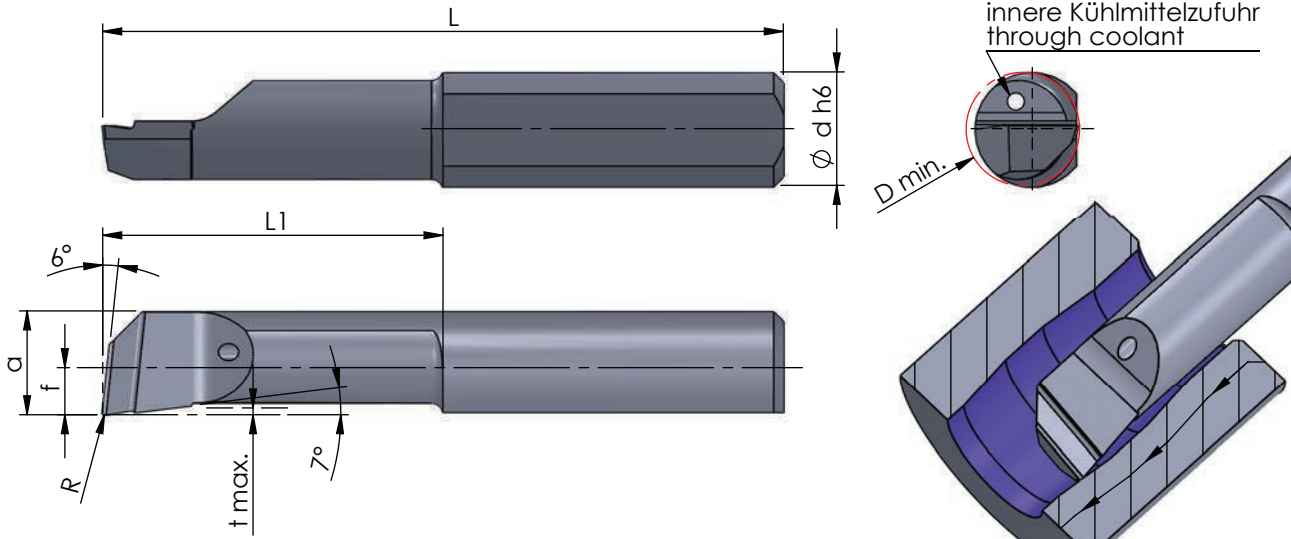

Rechts (R): wie gezeichnet
Links (L): spiegelbildlich

righthand (R): as shown
lefthand version (L): mirror image

Abmessungen in mm

dimensions in mm

Bestellnummer part number	R	f	a	L	L1	t max.	D min.	Ø d h6	Klemmhalter Typ toolholder type				
									K10F	CN45F	AL41F	P18C	
...													
R/L X050.6-15R05	0.05	2.5	5.5	30	15	0.4	6.0	6.0	●		●		
R/L X050.6-15R10	0.1	2.5	5.5	30	15	0.4	6.0	6.0	●		●		
R/L X050.6-15R20	0.2	2.5	5.5	30	15	0.4	6.0	6.0	●		●		
neu R/L X050.6-15R40	0.4	2.5	5.5	30	15	0.4	6.0	6.0			●		
R/L X050.6-22R20	0.2	2.5	5.5	37	22	0.4	6.0	6.0	●		●		
R/L X050.6-30R20	0.2	2.5	5.5	45	30	0.4	6.0	6.0	●		●		
neu R/L X050.6-30R40	0.4	2.5	5.5	45	30	0.4	6.0	6.0			●		
R/L X050.6-35R20	0.2	2.5	5.5	50	35	0.4	6.0	6.0	●		●		
neu R/L X050.6-42R20	0.2	2.5	5.5	57	42	0.4	6.0	6.0	●		●		
R/L X050.6-50R20	0.2	2.5	5.5	65	50	0.4	6.0	6.0	●		●		
↳ ...													

Weitere HM Sorten können Sie in der Sortenübersicht im Kapitel "Technische Hinweise" und der Preisliste finden.

Bestellbeispiel:
für rechte Ausführung und Sorte
RX050.6-15R05/P18C

weitere Informationen:
• siehe Allgemeine Beschreibung

more informations:
• look at the general instructions

More carbide grades you can find in the grades summary in the chapter "technical instructions" and in the price list.

order-example:
righthand version and grade
RX050.6-15R05/P18C

ULTRAMINI

Bohrungsbearbeitung
ab \varnothing 0.2 mm

grooving, boring and profiling
starting at \varnothing 0.2 mm

Xtraline Typ X050

Ausdrehen und Kopieren
mit innerer Kühlmittelzufuhr,
Spantreppe, extra stabile Ausführung

boring and profiling
with through coolant,
chipbreaker and extra solid construction

D min. 1.0 - 7.0 mm

D min. 1.0 - 7.0 mm

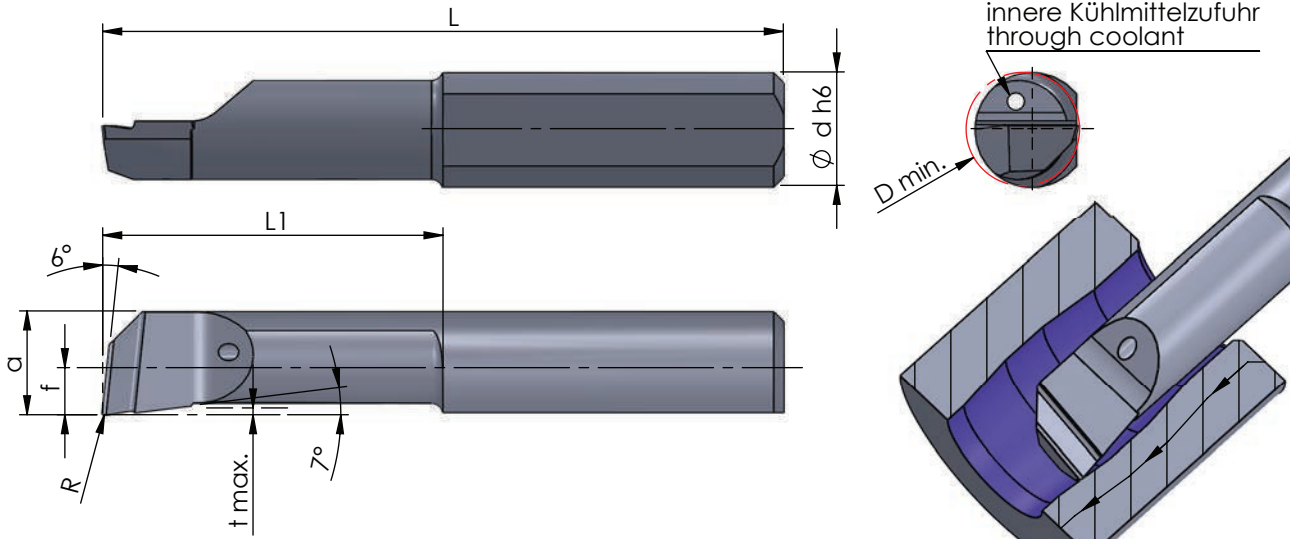

Rechts (R): wie gezeichnet
Links (L): spiegelbildlich

righthand (R): as shown
lefthand version (L): mirror image

Abmessungen in mm

dimensions in mm

neu
neu
neu
neu
neu

Bestellnummer part number	R	f	a	L	L1	t max.	D min.	$\varnothing d h6$	K10F	CN45F	AL41F	P18C	Klemmhalter Typ toolholder type		
↓															
R/L X050.7-25R20	0.2	3	6.5	40	25	0.5	7.0	7.0	●			●		676...	670... 687... ...7
R/L X050.7-30R20	0.2	3	6.5	45	30	0.5	7.0	7.0	●			●			
R/L X050.7-30R40	0.4	3	6.5	45	30	0.5	7.0	7.0				●			
R/L X050.7-35R20	0.2	3	6.5	50	35	0.5	7.0	7.0	●			●			
R/L X050.7-40R20	0.2	3	6.5	55	40	0.5	7.0	7.0	●			●			
R/L X050.7-45R20	0.2	3	6.5	60	45	0.5	7.0	7.0	●			●			
R/L X050.7-50R20	0.2	3	6.5	65	50	0.5	7.0	7.0	●			●			

Weitere HM Sorten können Sie in der Sortenübersicht im Kapitel "Technische Hinweise" und der Preisliste finden.

Bestellbeispiel:
für rechte Ausführung und Sorte
RX050.7-25R20/P18C

weitere Informationen:
• siehe Allgemeine Beschreibung

more informations:
• look at the general instructions

More carbide grades you can find in the grades summary in the chapter "technical instructions" and in the price list.

order-example:
righthand version and grade
RX050.7-25R20/P18C

ULTRAMINI

Bohrungsbearbeitung
ab $\varnothing 0.2$ mm

grooving, boring and profiling
starting at $\varnothing 0.2$ mm

Hardline Typ 050

Ausdrehen und Kopieren,
für Hartbearbeitung bis 66 HRC

boring and profiling,
for hard machining up to 66 HRC

D min. 2.0 - 6.8 mm
Auskrägung (L1) bis 7x D

D min. 2.0 - 6.8 mm
overhang length (L1) up to 7x D

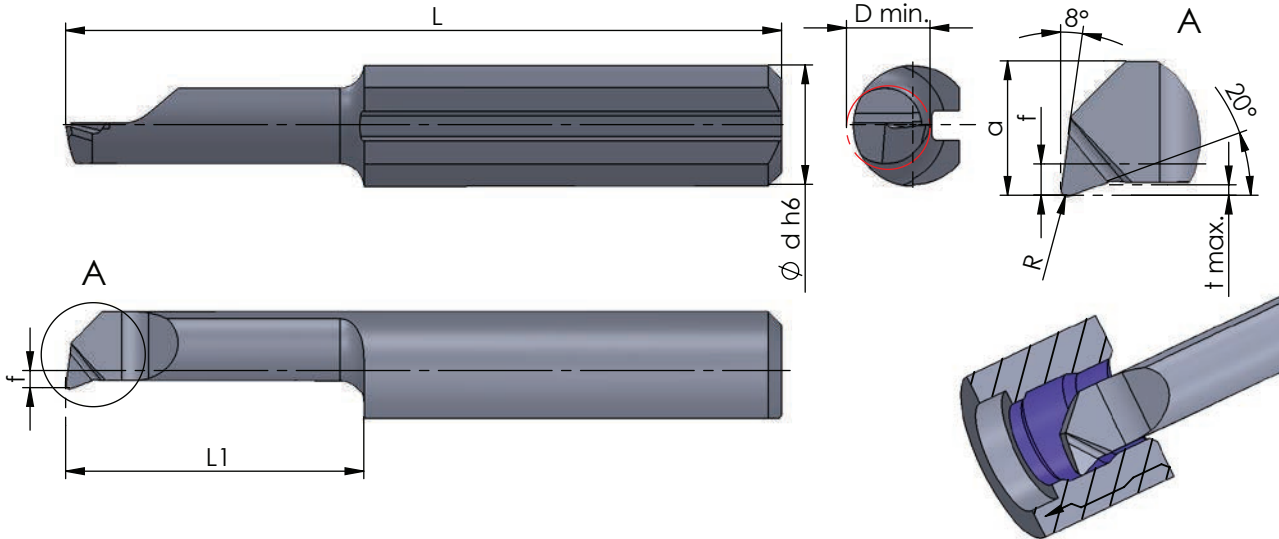

Rechts (R): wie gezeichnet
Links (L): spiegelbildlich

righthand (R): as shown
lefthand version (L): mirror image

Abmessungen in mm

dimensions in mm

Bestellnummer part number	R	f	a	L	L1	t max.	D min.	$\varnothing d h6$	K10F	CN45F	AL41F	XC2A-NH	Klemmhalter Typ toolholder type
R/L 050.2-5/XC2A-NH	0.05		1.7	19	5	0.1	2.0	4.0					645... 640... ...4
R/L 050.2-10/XC2A-NH	0.05		1.7	24	10	0.1	2.0	4.0					
R/L 050.2-15/XC2A-NH	0.05		1.7	29	15	0.1	2.0	4.0					
R/L 050.3-10/XC2A-NH	0.1	0.6	2.6	24	10	0.2	2.8	4.0					
R/L 050.3-16/XC2A-NH	0.1	0.6	2.6	30	16	0.2	2.8	4.0					
R/L 050.3-20/XC2A-NH	0.1	0.6	2.6	34	20	0.2	2.8	4.0					
R/L 050.4-10/XC2A-NH	0.1	1.5	3.5	24	10	0.3	4.0	4.0					
R/L 050.4-16/XC2A-NH	0.1	1.5	3.5	30	16	0.3	4.0	4.0					
R/L 050.4-20/XC2A-NH	0.1	1.5	3.5	34	20	0.3	4.0	4.0					
R/L 050.4-24/XC2A-NH	0.1	1.5	3.5	38	24	0.3	4.0	4.0					
R/L 050.4-28/XC2A-NH	0.1	1.5	3.5	42	28	0.3	4.0	4.0					
R/L 050.5-10/XC2A-NH	0.15	1.9	4.4	25	10	0.5	5.0	5.0					650... ...5
R/L 050.5-15/XC2A-NH	0.15	1.9	4.4	30	15	0.5	5.0	5.0					
R/L 050.5-20/XC2A-NH	0.15	1.9	4.4	35	20	0.5	5.0	5.0					
R/L 050.5-25/XC2A-NH	0.15	1.9	4.4	40	25	0.5	5.0	5.0					
↳ ...													

Weitere HM Sorten können Sie in der Sortenübersicht im Kapitel "Technische Hinweise" und der Preisliste finden.

Bestellbeispiel:
für rechte Ausführung und Sorte
R050.2-5/XC2A-NH

weitere Informationen:

- siehe Allgemeine Beschreibung

more informations:

- look at the general instructions

More carbide grades you can find in the grades summary in the chapter "technical instructions" and in the price list.

order-example:
righthand version and grade
R050.2-5/XC2A-NH

ULTRAMINI

Bohrungsbearbeitung
ab $\varnothing 0.2$ mm

grooving, boring and profiling
starting at $\varnothing 0.2$ mm

Hardline Typ 050

Ausdrehen und Kopieren,
für Hartbearbeitung bis 66 HRC

boring and profiling,
for hard machining up to 66 HRC

D min. 2.0 - 6.8 mm
Auskrägung (L1) bis 7x D

D min. 2.0 - 6.8 mm
overhang length (L1) up to 7x D

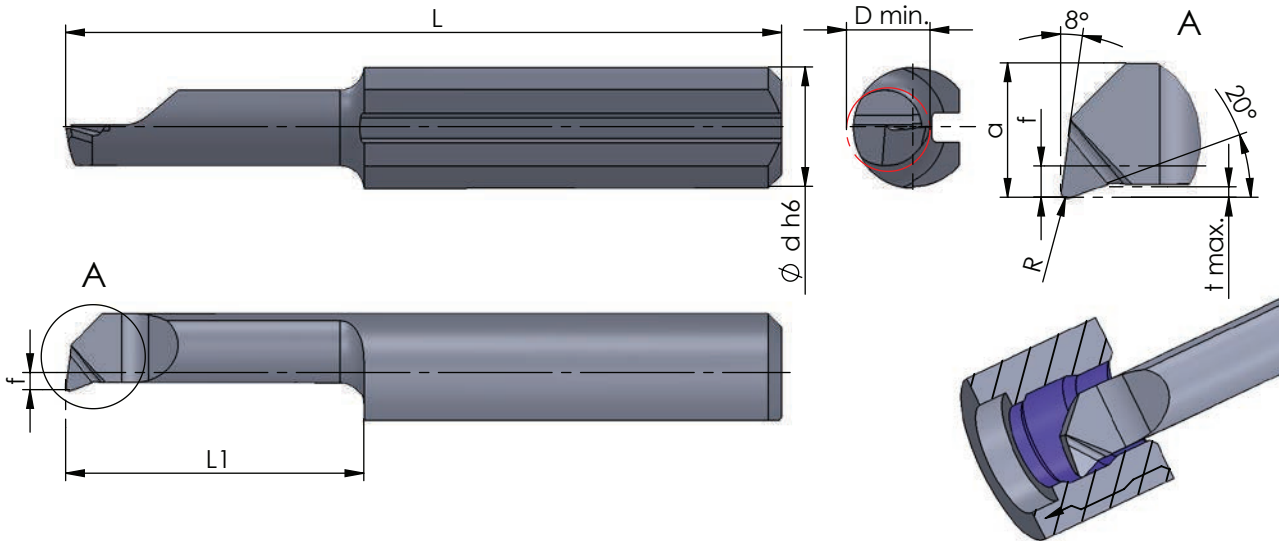

Rechts (R): wie gezeichnet
Links (L): spiegelbildlich

righthand (R): as shown
lefthand version (L): mirror image

Abmessungen in mm

dimensions in mm

Bestellnummer part number	R	f	a	L	L1	t max.	D min.	Ø d h6	K10F	CN45F	AL41F	XC2A-NH	Klemmhalter Typ toolholder type		
...															
R/L 050.5-30/XC2A-NH	0.15	1.9	4.4	45	30	0.5	5.0	5.0				●		645... 650... ...5	
R/L 050.5-35/XC2A-NH	0.15	1.9	4.4	50	35	0.5	5.0	5.0				●			
R/L 050.6-15/XC2A-NH	0.15	2.3	5.3	30	15	0.5	6.0	6.0				●			
R/L 050.6-22/XC2A-NH	0.15	2.3	5.3	37	22	0.5	6.0	6.0				●			
R/L 050.6-25/XC2A-NH	0.15	2.3	5.3	40	25	0.5	6.0	6.0				●		660... ...6	
R/L 050.6-30/XC2A-NH	0.15	2.3	5.3	45	30	0.5	6.0	6.0				●			
R/L 050.6-35/XC2A-NH	0.15	2.3	5.3	50	35	0.5	6.0	6.0				●			
R/L 050.6-42/XC2A-NH	0.15	2.3	5.3	57	42	0.5	6.0	6.0				●			
R/L 050.7-20/XC2A-NH	0.15	2.8	6.3	35	20	0.6	6.8	7.0				●	676...		
R/L 050.7-25/XC2A-NH	0.15	2.8	6.3	40	25	0.6	6.8	7.0				●			
R/L 050.7-30/XC2A-NH	0.15	2.8	6.3	45	30	0.6	6.8	7.0				●			
R/L 050.7-35/XC2A-NH	0.15	2.8	6.3	50	35	0.6	6.8	7.0				●		670... 687... ...7	
R/L 050.7-40/XC2A-NH	0.15	2.8	6.3	55	40	0.6	6.8	7.0				●			
R/L 050.7-45/XC2A-NH	0.15	2.8	6.3	60	45	0.6	6.8	7.0				●			
R/L 050.7-50/XC2A-NH	0.15	2.8	6.3	65	50	0.6	6.8	7.0				●			

Weitere HM Sorten können Sie in der Sortenübersicht im Kapitel "Technische Hinweise" und der Preisliste finden.

weitere Informationen:

- siehe Allgemeine Beschreibung

More carbide grades you can find in the grades summary in the chapter "technical instructions" and in the price list.

Bestellbeispiel:
für rechte Ausführung und Sorte
R050.5-30/XC2A-NH

more informations:

- look at the general instructions

order-example:
righthand version and grade
R050.5-30/XC2A-NH

ULTRAMINI

Bohrungsbearbeitung
ab \varnothing 0.2 mm

grooving, boring and profiling
starting at \varnothing 0.2 mm

Typ 050..../CBN

Ausdrehen und Kopieren,
für Hartbearbeitung

boring and profiling,
for hard machining

D min. 2.8 - 6.8 mm

D min. 2.8 - 6.8 mm

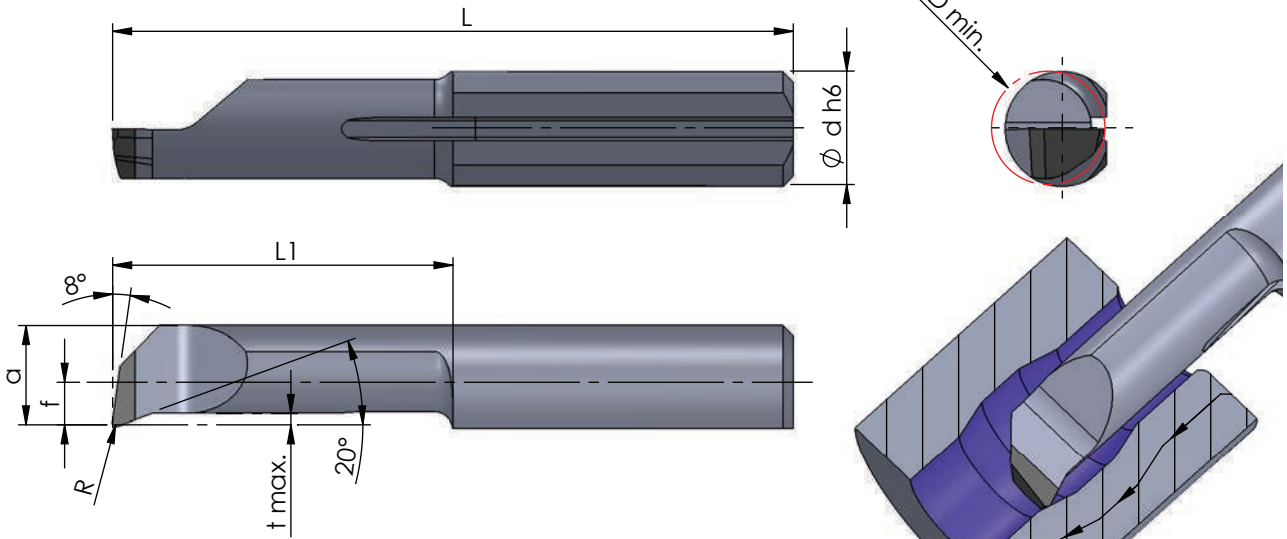

Rechts (R): wie gezeichnet
Links (L): spiegelbildlich

righthand (R): as shown
lefthand version (L): mirror image

Abmessungen in mm

dimensions in mm

Bestellnummer part number									K10F CN45F AL41F CBN	Klemmhalter Typ toolholder type	
	R	f	a	L	L1	t max.	D min.	\varnothing d h6			
R 050.3-10/CBN	0.1	0.6	2.6	25.5	10	0.2	2.8	4.0	●	645...	640... ...4
R 050.4-10/CBN	0.1	1.5	3.5	25.5	10	0.3	4.0	4.0	●		650... ...5
R 050.5-15/CBN	0.15	1.9	4.4	31.5	15	0.5	5.0	5.0	●	676...	660... ...6
R 050.6-15/CBN	0.15	2.3	5.3	31.5	15	0.5	6.0	6.0	●		670... 687... ...7
R 050.7-20/CBN	0.15	2.8	6.3	36.5	20	0.6	6.8	7.0	●		

Weitere HM Sorten können Sie in der Sorten-
übersicht im Kapitel "Technische Hinweise" und
der Preisliste finden.

Bestellbeispiel:
für rechte Ausführung und Sorte
R050.3-10/CBN

More carbide grades you can find in the grades
summary in the chapter "technical instructions"
and in the price list.

order-example:
righthand version and grade
R050.3-10/CBN

ULTRAMINI

Bohrungsbearbeitung
ab \varnothing 0.2 mm

grooving, boring and profiling
starting at \varnothing 0.2 mm

Typ 047

Audreihen und Kopieren
mit Geometrie $47^\circ / 8^\circ$

boring and profiling
with geometry $47^\circ / 8^\circ$

D min. 2.0 - 6.0 mm

D min. 2.0 - 6.0 mm

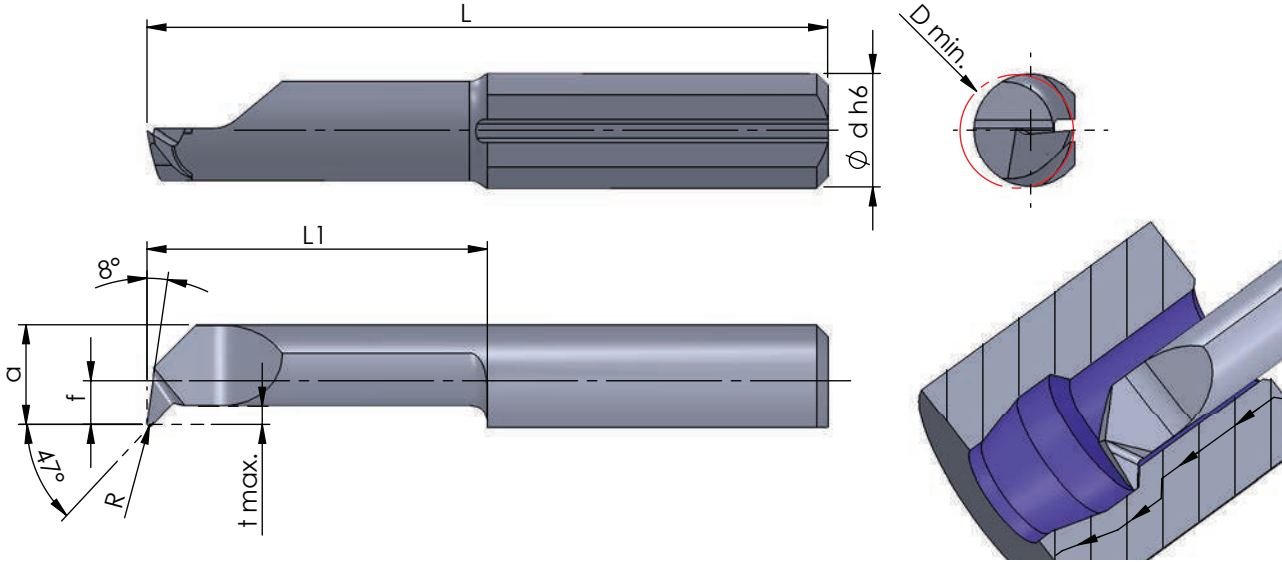

Rechts (R): wie gezeichnet
Links (L): spiegelbildlich

righthand (R): as shown
lefthand version (L): mirror image

Abmessungen in mm

dimensions in mm

Bestellnummer part number	R	f	a	L	L1	t max.	D min.	Ø d h6	K10F	CN45F	AL41F	P07C	Klemmhalter Typ toolholder type	
													645... 645... 645...	640... ...4 650... ...5
R/L 047T2-10	0.05		1.7	24	10	0.4	2.0	4.0			●		645... 645... 645...	640... ...4 650... ...5
R/L 047T3-15	0.1	0.6	2.6	29	15	0.6	2.8	4.0	●		●			
R/L 047T4-10	0.1	1.5	3.5	24	10	0.6	4.0	4.0			●			
R/L 047.4-20	0.1	1.5	3.5	34	20	0.3	4.0	4.0	●	●	●			
R/L 047T4-20	0.1	1.5	3.5	34	20	0.6	4.0	4.0			●		676... 660... ...6	
R/L 047T5-15	0.15	1.9	4.4	30	15	0.8	5.0	5.0			●			
R/L 047.5-25	0.15	1.9	4.4	40	25	0.5	5.0	5.0	●	●	●			
R/L 047T5-25	0.15	1.9	4.4	40	25	0.8	5.0	5.0			●			
R/L 047T6-22	0.15	2.3	5.3	37	22	1.8	6.0	6.0			●			
R/L 047.6-30	0.15	2.3	5.3	45	30	0.5	6.0	6.0	●	●	●			
R/L 047T6-30	0.15	2.3	5.3	45	30	1.8	6.0	6.0			●			

Weitere HM Sorten können Sie in der Sortenübersicht im Kapitel "Technische Hinweise" und der Preisliste finden.

Bestellbeispiel:
für rechte Ausführung und Sorte
R047T2-10/AL41F

More carbide grades you can find in the grades summary in the chapter "technical instructions" and in the price list.

order-example:
righthand version and grade
R047T2-10/AL41F

ULTRAMINI

Bohrungsbearbeitung
ab $\varnothing 0.2$ mm

grooving, boring and profiling
starting at $\varnothing 0.2$ mm

Typ 090

Ausdrehen und Kopieren
mit Geometrie $20^\circ / 90^\circ$

boring and profiling
with geometry $20^\circ / 90^\circ$

D min. 2.8 - 5.0 mm

D min. 2.8 - 5.0 mm

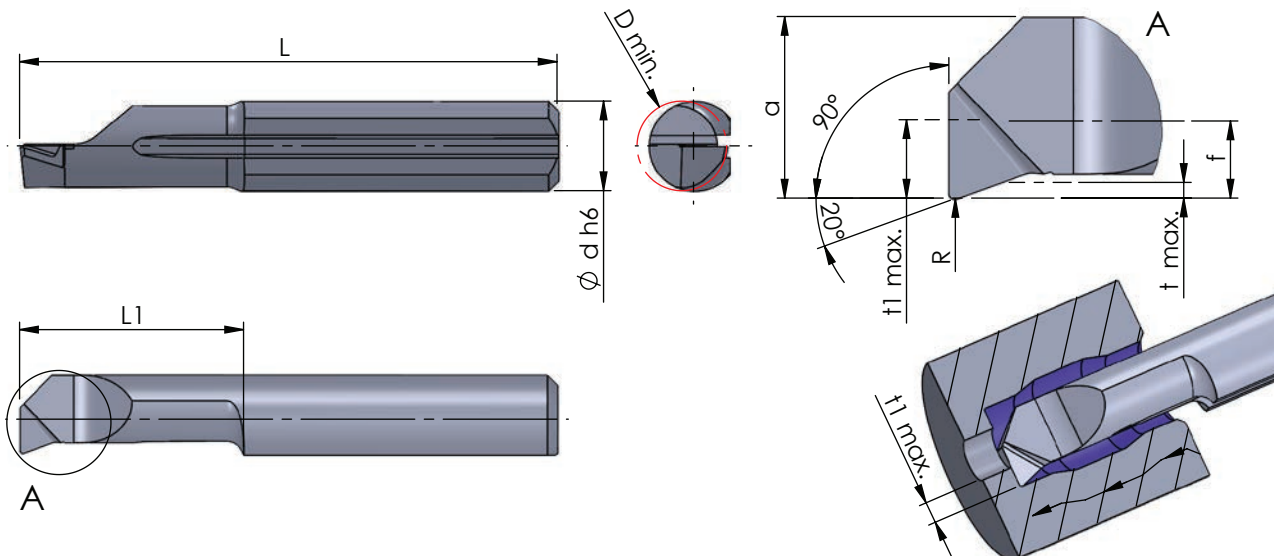

Rechts (R): wie gezeichnet
Links (L): spiegelbildlich

righthand (R): as shown
lefthand version (L): mirror image

Abmessungen in mm

dimensions in mm

Bestellnummer part number	R	f	a	L	L1	t max.	t1 max.	D min.	Ø d h6	Klemmhalter Typ				Klemmhalter Typ	toolholder type
										K10F	CN45F	AL41F	P07C		
R/L 090.3-10	0.1	0.6	2.6	24	10	0.2	0.8	2.8	4.0	●	●	●	●	645...	640... ...4
R/L 090.3-16	0.1	0.6	2.6	30	16	0.2	0.8	2.8	4.0	●	●	●	●		
R/L 090.4-10	0.1	1.5	3.5	24	10	0.3	1.5	4.0	4.0	●	●	●	●		
R/L 090.4-16	0.1	1.5	3.5	30	16	0.3	1.5	4.0	4.0	●	●	●	●		
R/L 090.5-10	0.15	1.9	4.4	25	10	0.5	1.8	5.0	5.0	●	●	●	●	650... ...5	
R/L 090.5-15	0.15	1.9	4.4	30	15	0.5	1.8	5.0	5.0	●	●	●	●		
R/L 090.5-20	0.15	1.9	4.4	35	20	0.5	1.8	5.0	5.0	●	●	●	●		

Weitere HM Sorten können Sie in der Sortenübersicht im Kapitel "Technische Hinweise" und der Preisliste finden.

Bestellbeispiel:
für rechte Ausführung und Sorte
R090.3-10/CN45F

More carbide grades you can find in the grades summary in the chapter "technical instructions" and in the price list.

order-example:
righthand version and grade
R090.3-10/CN45F

ULTRAMINI

Bohrungsbearbeitung
ab $\varnothing 0.2$ mm

grooving, boring and profiling
starting at $\varnothing 0.2$ mm

Typ 080

Rückwärtsdrehen

D min. 3.0 - 7.0 mm

backboring

D min. 3.0 - 7.0 mm

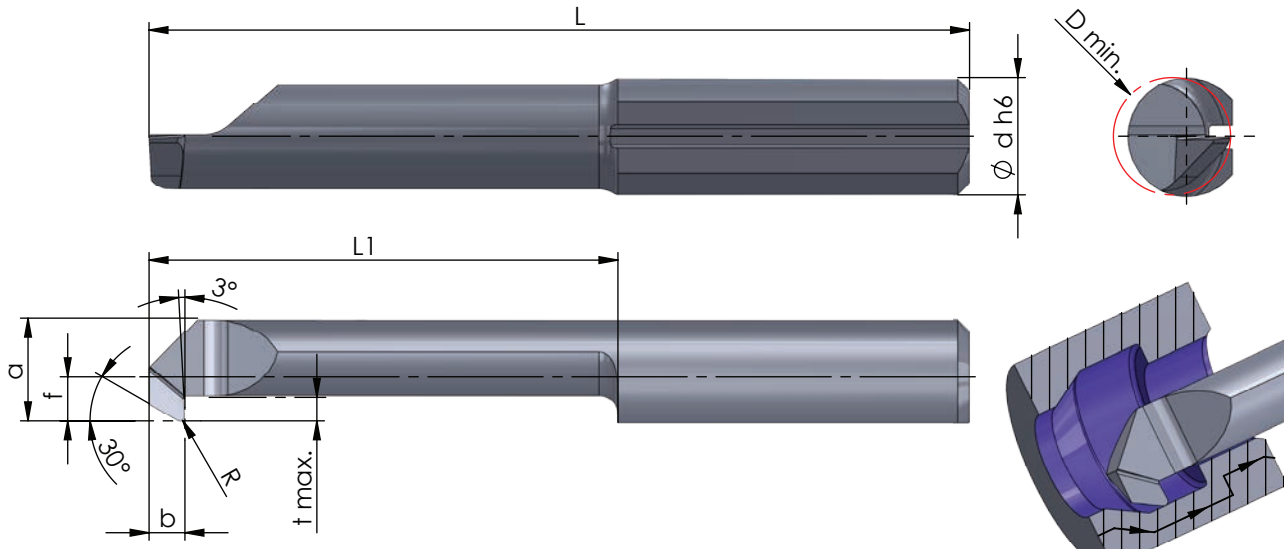

Rechts (R): wie gezeichnet
Links (L): spiegelbildlich

righthand (R): as shown
lefthand version (L): mirror image

Abmessungen in mm

dimensions in mm

Bestellnummer part number	b	R	f	a	L	L1	t max.	D min.	Ø d h6					Klemhalter Typ toolholder type	
										K10F	CN45F	AL41F	PD2F		
R/L 080.0003-15	1.5	0.1	0.6	2.6	29	15	0.5	3.0	4.0	●					
R/L 080.0003-20	1.5	0.1	0.6	2.6	34	20	0.5	3.0	4.0	●					
R/L 080.0004-15	1.5	0.15	1.5	3.5	29	15	0.8	4.0	4.0	●					
R/L 080.0004-25	1.5	0.15	1.5	3.5	39	25	0.8	4.0	4.0	●					
R/L 080.0005-20	1.5	0.2	1.9	4.4	35	20	1.0	5.0	5.0	●					
R/L 080.0005-30	1.5	0.2	1.9	4.4	45	30	1.0	5.0	5.0	●					
R/L 080.0006-20	1.5	0.2	2.3	5.3	35	20	1.8	6.0	6.0	●					
R/L 080.0006-30	1.5	0.2	2.3	5.3	45	30	1.8	6.0	6.0	●					
R/L 080.0007-20	1.5	0.2	2.8	6.3	35	20	2.5	7.0	7.0	●					
R/L 080.0007-30	1.5	0.2	2.8	6.3	45	30	2.5	7.0	7.0	●					

Weitere HM Sorten können Sie in der Sortenübersicht im Kapitel "Technische Hinweise" und der Preisliste finden.

Bestellbeispiel:
für rechte Ausführung und Sorte
R080.0003-15/CN45F

More carbide grades you can find in the grades summary in the chapter "technical instructions" and in the price list.

order-example:
righthand version and grade
R080.0003-15/CN45F

ULTRAMINI

Bohrungsbearbeitung
ab \varnothing 0.2 mm

grooving, boring and profiling
starting at \varnothing 0.2 mm

Impressionen

impressions

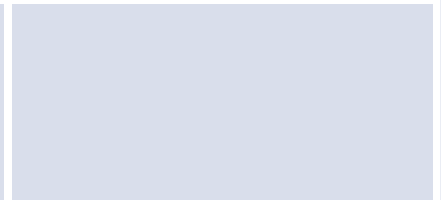
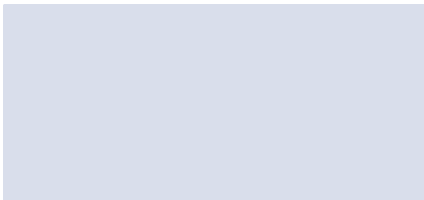
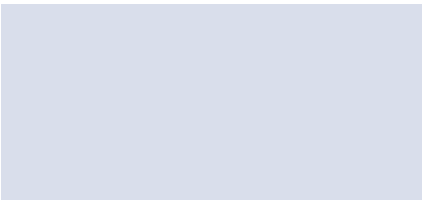
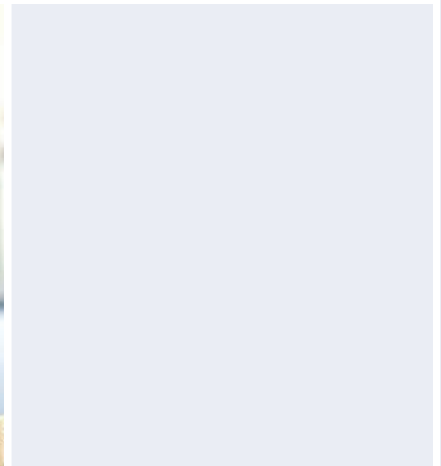
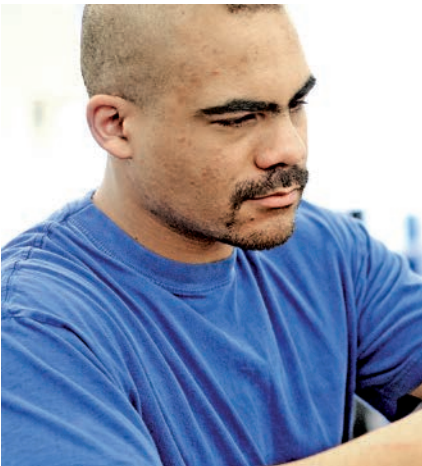
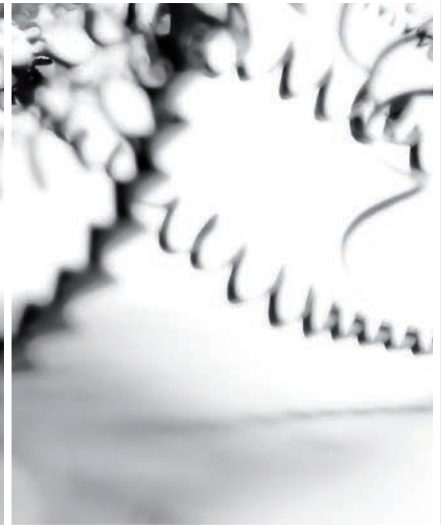
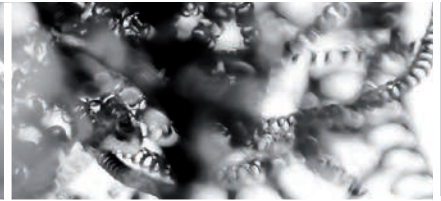
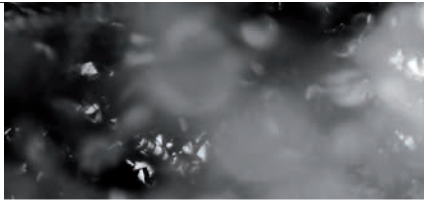

ULTRAMINI

Bohrungsbearbeitung
ab $\varnothing 0.2$ mm

grooving, boring and profiling
starting at $\varnothing 0.2$ mm

Typ 001 / 0015

Stechdrehen

D min. 1.0 / 1.5 mm
Stechtiefe t max. 0.2 / 0.4 mm

grooving

D min. 1.0 / 1.5 mm
depth of groove t max. 0.2 / 0.4 mm

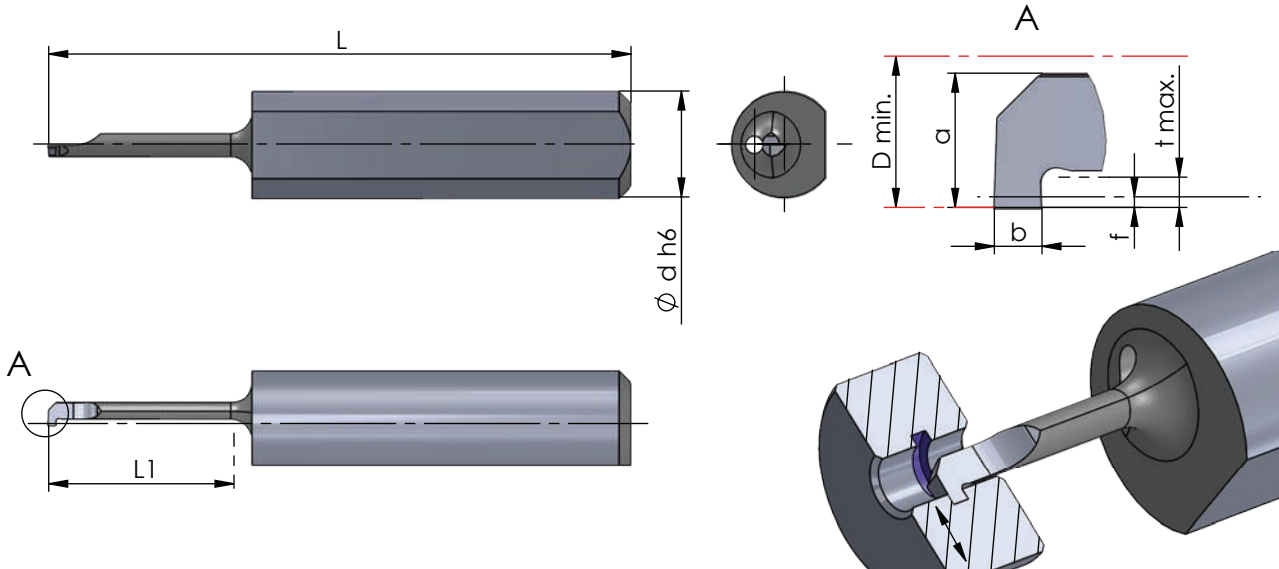

Rechts (R): wie gezeichnet
Links (L): spiegelbildlich

righthand (R): as shown
lefthand version (L): mirror image

Abmessungen in mm

dimensions in mm

	Bestellnummer part number	b +0.03	a	f	L	L1	t max.	D min.	Ø d h6	Klemmhalter Typ toolholder type				
										K10F	CN45F	AL41F	P07C	
neu	R/L 001.0030-4	0.3	0.9	0.1	20	4	0.2	1.0	4.0			●		640... 645... ...4
neu	R/L 001.0030-7	0.3	0.9	0.1	22	7	0.2	1.0	4.0			●		
neu	R/L 0015.0040-5	0.4	1.4	0.55	22	5	0.4	1.5	4.0			●		
neu	R/L 0015.0040-10	0.4	1.4	0.55	25	10	0.4	1.5	4.0			●		
neu	R/L 0015.0040-12	0.4	1.4	0.55	27	12	0.4	1.5	4.0			●		

Weitere HM Sorten können Sie in der Sortenübersicht im Kapitel "Technische Hinweise" und der Preisliste finden.

Bestellbeispiel:
für rechte Ausführung und Sorte
R001.0030-4/AL41F

More carbide grades you can find in the grades summary in the chapter "technical instructions" and in the price list.

order-example:
righthand version and grade
R001.0030-4/AL41F

ULTRAMINI

Bohrungsbearbeitung
ab $\varnothing 0.2 \text{ mm}$

grooving, boring and profiling
starting at $\varnothing 0.2 \text{ mm}$

Typ 002

Stechdrehen

grooving

D min. 2.0 mm
Stechtiefe t max. 0.4 mm

D min. 2.0 mm
depth of groove t max. 0.4 mm

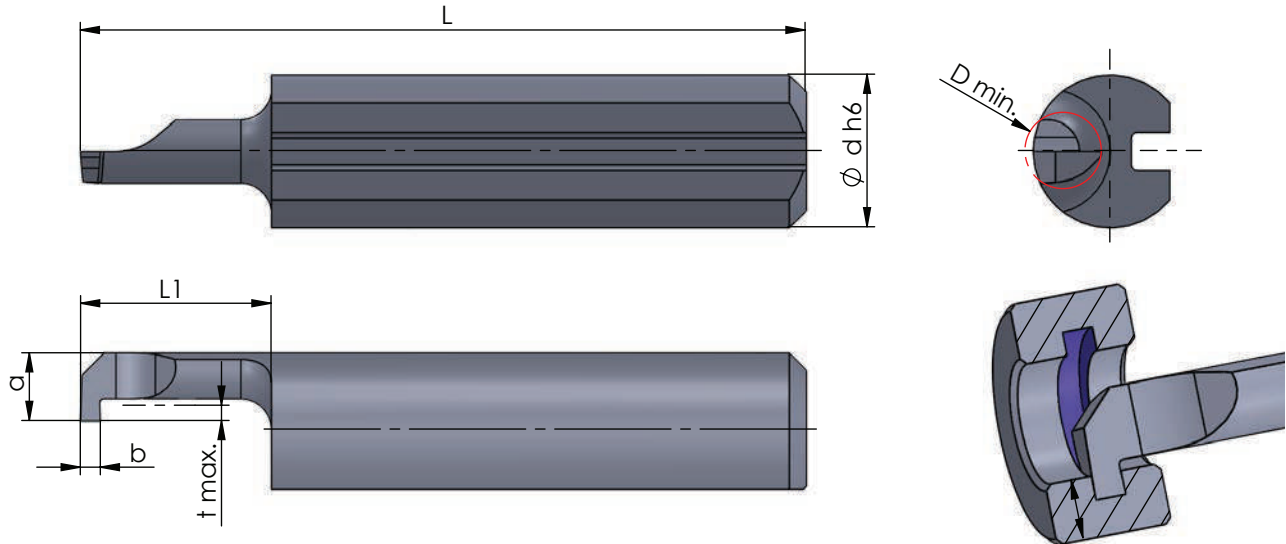

Rechts (R): wie gezeichnet
Links (L): spiegelbildlich

righthand (R): as shown
lefthand version (L): mirror image

Abmessungen in mm

dimensions in mm

Bestellnummer part number	b +0.05	a	L	L1	t max.	D min.	$\varnothing d h6$	Klemmhalter Typ toolholder type			
								K10F	CN45F	AL41F	P07C
R/L 002.0050-5	0.5	1.8	19	5	0.4	2.0	4.0		●		
R/L 002.0050-10	0.5	1.8	24	10	0.4	2.0	4.0		●		640... 645... ...4
R/L 002.0050-15	0.5	1.8	29	15	0.4	2.0	4.0		●		

Weitere HM Sorten können Sie in der Sortenübersicht im Kapitel "Technische Hinweise" und der Preisliste finden.

Bestellbeispiel:
für rechte Ausführung und Sorte
R002.0050-5/AL41F

More carbide grades you can find in the grades summary in the chapter "technical instructions" and in the price list.

order-example:
righthand version and grade
R002.0050-5/AL41F

ULTRAMINI

Bohrungsbearbeitung
ab \varnothing 0.2 mm

grooving, boring and profiling
starting at \varnothing 0.2 mm

Typ 003

Stechdrehen

grooving

D min. 3.0 mm
Stechtiefe t max. 0.6 mm

D min. 3.0 mm
depth of groove t max. 0.6 mm

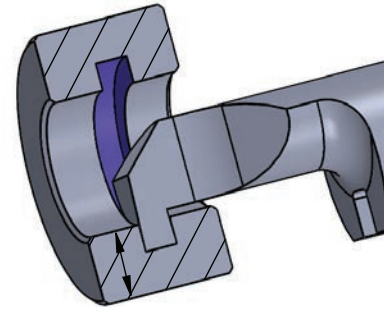
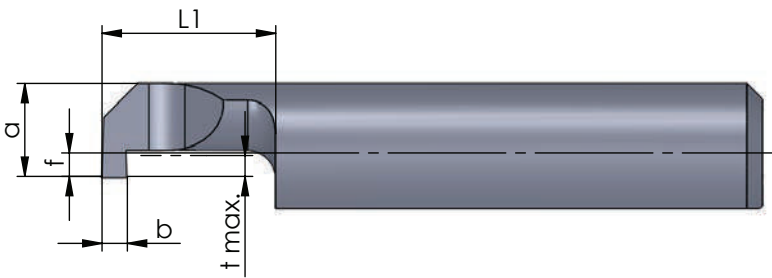
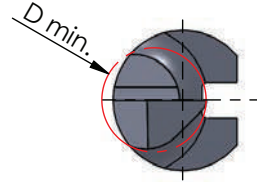

Rechts (R): wie gezeichnet
Links (L): spiegelbildlich

righthand (R): as shown
lefthand version (L): mirror image

Abmessungen in mm

dimensions in mm

Bestellnummer part number	b +0.05	f	a	L	L1	t max.	D min.	\varnothing d h6	K10F CN45F AL41F P07C	Klemmhalter Typ	toolholder type
R/L 003.0070-5	0.7	0.7	2.7	19	5	0.6	3.0	4.0			
R/L 003.0070-10	0.7	0.7	2.7	24	10	0.6	3.0	4.0			640... 645... ...4
R/L 003.0070-16	0.7	0.7	2.7	30	16	0.6	3.0	4.0			

Weitere HM Sorten können Sie in der Sortenübersicht im Kapitel "Technische Hinweise" und der Preisliste finden.

Bestellbeispiel:
für rechte Ausführung und Sorte
R003.0070-5/AL41F

More carbide grades you can find in the grades summary in the chapter "technical instructions" and in the price list.

order-example:
righthand version and grade
R003.0070-5/AL41F

ULTRAMINI

Bohrungsbearbeitung
ab $\varnothing 0.2 \text{ mm}$

grooving, boring and profiling
starting at $\varnothing 0.2 \text{ mm}$

Typ 004

Stechdrehen

D min. 4.0 mm
Stechtiefe t max. 0.8 mm

grooving

D min. 4.0 mm
depth of groove t max. 0.8 mm

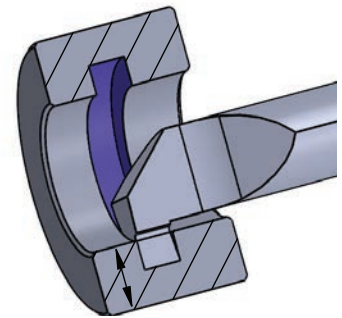
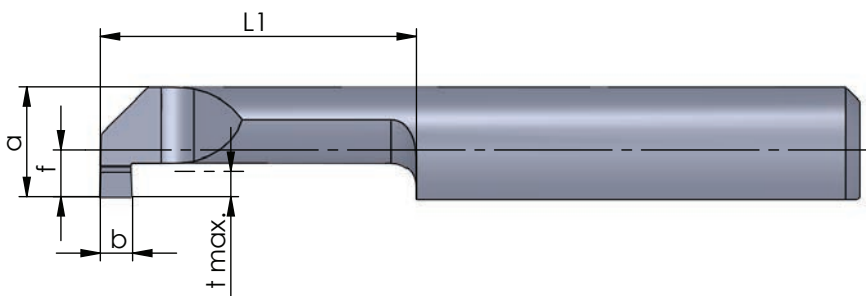
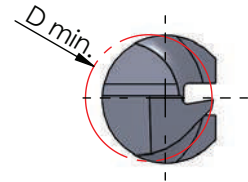
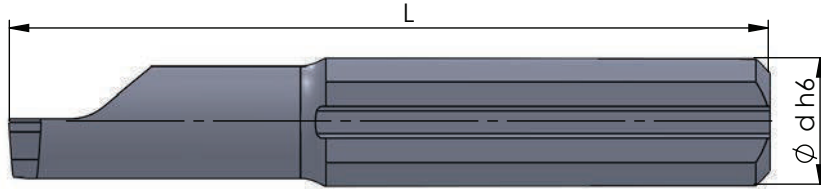

Rechts (R): wie gezeichnet
Links (L): spiegelbildlich

righthand (R): as shown
lefthand version (L): mirror image

Abmessungen in mm

dimensions in mm

Bestellnummer part number	b +0.05	f	a	L	L1	t max.	D min.	Ø d h6					Klemmhalter Typ toolholder type
									K10F	CN45F	AL41F	P07C	
R/L 004.0100-10	1.0	1.5	3.5	24	10	0.8	4.0	4.0	●	●	●		
R/L 004.0100-16	1.0	1.5	3.5	30	16	0.8	4.0	4.0	●	●	●		640... 645... ...4
R/L 004.0100-20	1.0	1.5	3.5	34	20	0.8	4.0	4.0	●	●	●		

Weitere HM Sorten können Sie in der Sortenübersicht im Kapitel "Technische Hinweise" und der Preisliste finden.

Bestellbeispiel:
für rechte Ausführung und Sorte
R004.0100-10/AL41F

More carbide grades you can find in the grades summary in the chapter "technical instructions" and in the price list.

order-example:
righthand version and grade
R004.0100-10/AL41F

ULTRAMINI

Bohrungsbearbeitung
ab $\varnothing 0.2$ mm

grooving, boring and profiling
starting at $\varnothing 0.2$ mm

Typ 004M

Stechdrehen
mit Eckenradius

grooving
with corner radius

D min. 4.0 mm
Stechtiefe t max. 0.8 mm

D min. 4.0 mm
depth of groove t max. 0.8 mm

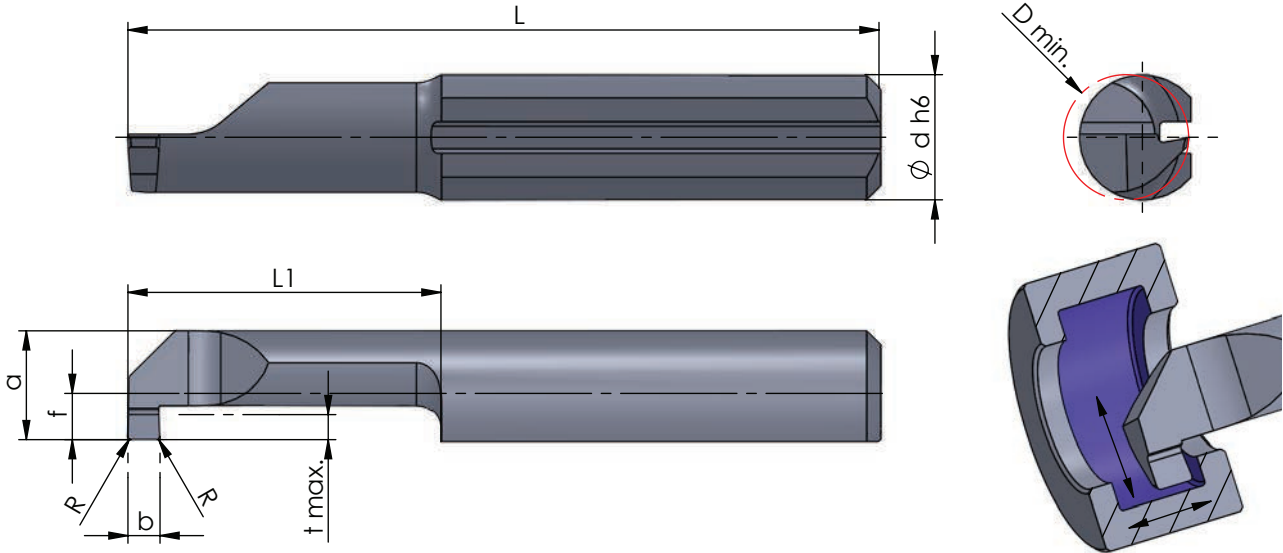

Rechts (R): wie gezeichnet
Links (L): spiegelbildlich

righthand (R): as shown
lefthand version (L): mirror image

Abmessungen in mm

dimensions in mm

Bestellnummer part number	b +0.05	b (inch)	R	f	a	L	L1	t max.	D min.	$\varnothing d h6$	Klemmhalter Typ toolholder type				
											K10F	CN45F	AL41F	P07C	
R/L 004M0079-20	0.79	0.031"	0.1	1.5	3.5	34	20	0.8	4.0	4.0	●				
R/L 004M0100-10	1.0		0.1	1.5	3.5	24	10	0.8	4.0	4.0	●				
R/L 004M0100-16	1.0		0.1	1.5	3.5	30	16	0.8	4.0	4.0	●				640... 645... ...4
R/L 004M0100-20	1.0		0.1	1.5	3.5	34	20	0.8	4.0	4.0	●				

Weitere HM Sorten können Sie in der Sortenübersicht im Kapitel "Technische Hinweise" und der Preisliste finden.

Bestellbeispiel:
für rechte Ausführung und Sorte
R004M0079-20/AL41F

More carbide grades you can find in the grades summary in the chapter "technical instructions" and in the price list.

order-example:
righthand version and grade
R004M0079-20/AL41F

ULTRAMINI

Bohrungsbearbeitung
ab \varnothing 0.2 mm

grooving, boring and profiling
starting at \varnothing 0.2 mm

Typ 005

Stechdrehen

grooving

D min. 5.0 mm
Stechtiefe t max. 1.0 mm
Auskragung (L1) bis 7x D

D min. 5.0 mm
depth of groove t max. 1.0 mm
overhang length (L1) up to 7x D

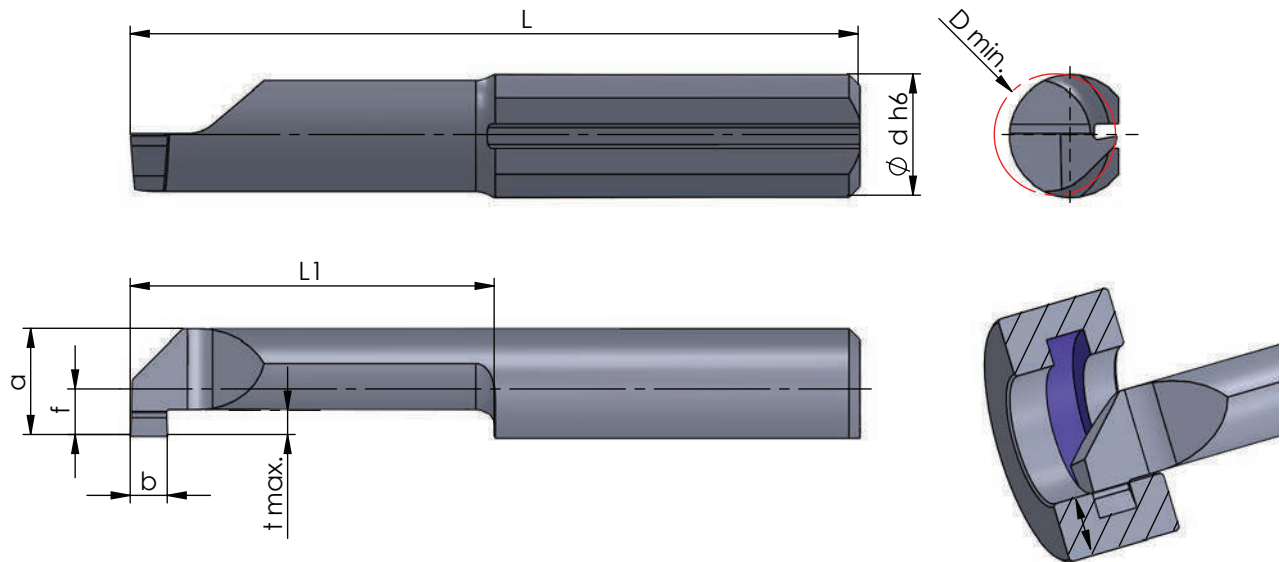

Rechts (R): wie gezeichnet
Links (L): spiegelbildlich

righthand (R): as shown
lefthand version (L): mirror image

Abmessungen in mm

dimensions in mm

neu

Bestellnummer part number	b +0.05		f	a	L	L1	t max.	D min.	Ø d h6	K10F	CN45F	AL41F	P07C	Klemmhalter Typ toolholder type
	b (inch)	b (inch)												
R/L 005.0100-10	1.0		1.9	4.4	25	10	1.0	5.0	5.0	●	●			645... 650... ...5
R/L 005.0100-15	1.0		1.9	4.4	30	15	1.0	5.0	5.0	●	●			
R/L 005.0100-20	1.0		1.9	4.4	35	20	1.0	5.0	5.0	●	●			
R/L 005.0100-25	1.0		1.9	4.4	40	25	1.0	5.0	5.0	●	●			
R/L 005.0100-30	1.0		1.9	4.4	45	30	1.0	5.0	5.0	●	●			
R/L 005.0100-35	1.0		1.9	4.4	50	35	1.0	5.0	5.0		●			
R/L 005.0117-30	1.17	0.046"	1.9	4.4	45	30	1.0	5.0	5.0			●		
R/L 005.0150-10	1.5		1.9	4.4	25	10	1.0	5.0	5.0	●	●			
R/L 005.0150-15	1.5		1.9	4.4	30	15	1.0	5.0	5.0	●	●			
R/L 005.0150-20	1.5		1.9	4.4	35	20	1.0	5.0	5.0	●	●			
R/L 005.0150-25	1.5		1.9	4.4	40	25	1.0	5.0	5.0	●	●			
R/L 005.0150-30	1.5		1.9	4.4	45	30	1.0	5.0	5.0	●	●			
↳ ...														

Weitere HM Sorten können Sie in der Sortenübersicht im Kapitel "Technische Hinweise" und der Preisliste finden.

Bestellbeispiel:
für rechte Ausführung und Sorte
R005.0100-10/CN45F

More carbide grades you can find in the grades summary in the chapter "technical instructions" and in the price list.

order-example:
righthand version and grade
R005.0100-10/CN45F

ULTRAMINI

Bohrungsbearbeitung
ab \varnothing 0.2 mm

grooving, boring and profiling
starting at \varnothing 0.2 mm

Typ 005

Stechdrehen

grooving

D min. 5.0 mm
Stechtiefe t max. 1.0 mm
Auskragung (L1) bis 7x D

D min. 5.0 mm
depth of groove t max. 1.0 mm
overhang length (L1) up to 7x D

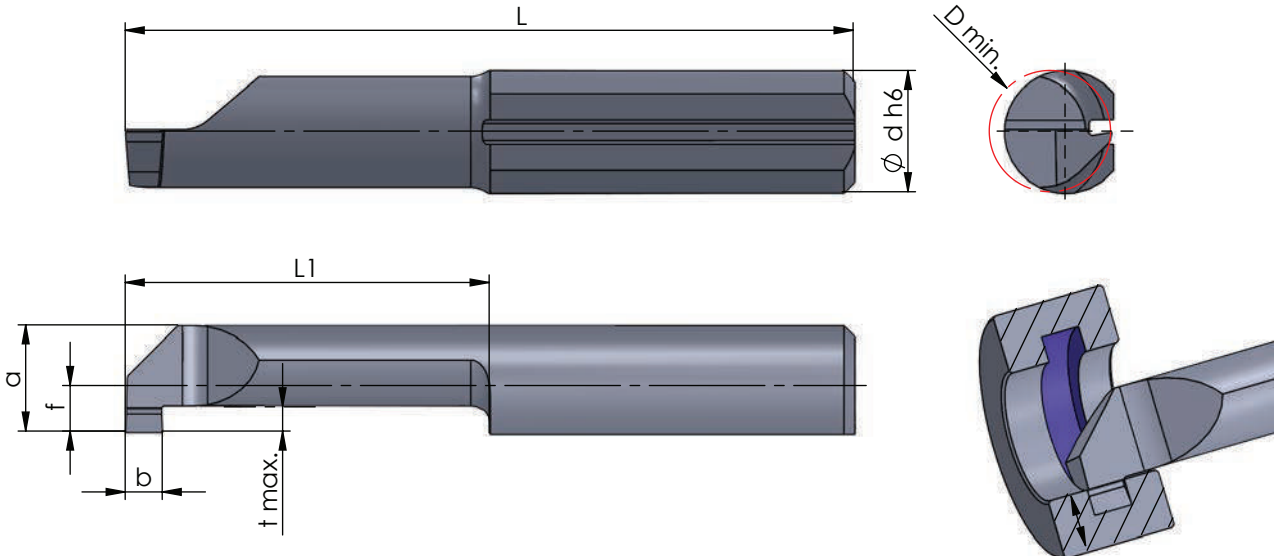

Rechts (R): wie gezeichnet
Links (L): spiegelbildlich

righthand (R): as shown
lefthand version (L): mirror image

Abmessungen in mm

dimensions in mm

Bestellnummer part number	b +0.05	b (inch)	f	a	L	L1	t max.	D min.	\varnothing d h6	Klemmhalter Typ toolholder type				
										K10F	CN45F	AL41F	P07C	
⋮ ↓														
R/L 005.0200-10	2.0		1.9	4.4	25	10	1.0	5.0	5.0	●	●			
R/L 005.0200-15	2.0		1.9	4.4	30	15	1.0	5.0	5.0	●	●			
R/L 005.0200-20	2.0		1.9	4.4	35	20	1.0	5.0	5.0	●	●			
R/L 005.0200-25	2.0		1.9	4.4	40	25	1.0	5.0	5.0	●	●			
R/L 005.0200-30	2.0		1.9	4.4	45	30	1.0	5.0	5.0	●	●			
													645... 650... ...5	

Weitere HM Sorten können Sie in der Sortenübersicht im Kapitel "Technische Hinweise" und der Preisliste finden.

More carbide grades you can find in the grades summary in the chapter "technical instructions" and in the price list.

Bestellbeispiel:
für rechte Ausführung und Sorte
R005.0200-10/CN45F

order-example:
righthand version and grade
R005.0200-10/CN45F

ULTRAMINI

Bohrungsbearbeitung
ab $\varnothing 0.2 \text{ mm}$

grooving, boring and profiling
starting at $\varnothing 0.2 \text{ mm}$

Typ 005M

Stechdrehen
mit Eckenradius

grooving
with corner radius

D min. 5.0 mm
Stechtiefe t max. 1.0 mm

D min. 5.0 mm
depth of groove t max. 1.0 mm

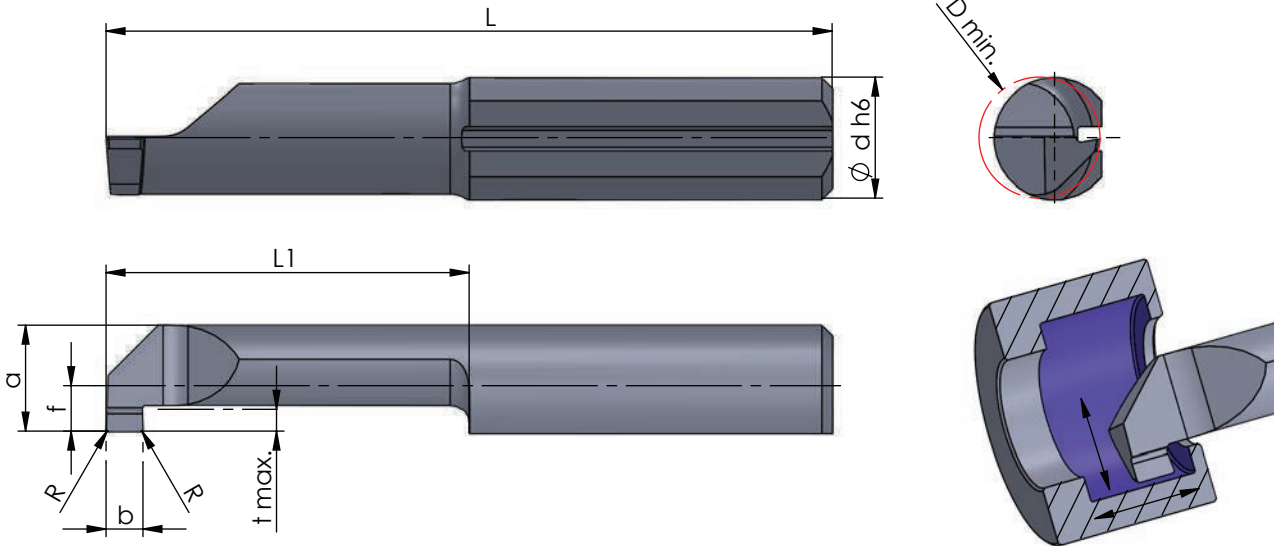

Rechts (R): wie gezeichnet
Links (L): spiegelbildlich

righthand (R): as shown
lefthand version (L): mirror image

Abmessungen in mm

dimensions in mm

Bestellnummer part number	b +0.05	b (inch)	R	f	a	L	L1	t max.	D min.	$\varnothing d h6$	Klemmhalter Typ toolholder type					
											K10F	CN45F	AL41F	P07C		
R/L 005M0100-10	1.0		0.1	1.9	4.4	25	10	1.0	5.0	5.0		●				
R/L 005M0100-15	1.0		0.1	1.9	4.4	30	15	1.0	5.0	5.0		●				
R/L 005M0100-20	1.0		0.1	1.9	4.4	35	20	1.0	5.0	5.0		●				
R/L 005M0100-25	1.0		0.1	1.9	4.4	40	25	1.0	5.0	5.0		●				
R/L 005M0100-30	1.0		0.1	1.9	4.4	45	30	1.0	5.0	5.0		●				
R/L 005M0150-10	1.5		0.1	1.9	4.4	25	10	1.0	5.0	5.0		●			645... 650... ...5	
R/L 005M0150-15	1.5		0.1	1.9	4.4	30	15	1.0	5.0	5.0		●				
R/L 005M0150-20	1.5		0.1	1.9	4.4	35	20	1.0	5.0	5.0		●				
R/L 005M0150-25	1.5		0.1	1.9	4.4	40	25	1.0	5.0	5.0		●				
R/L 005M0150-30	1.5		0.1	1.9	4.4	45	30	1.0	5.0	5.0		●				
R/L 005M0157-20	1.57	0.062"	0.1	1.9	4.4	35	20	1.0	5.0	5.0		●				
↳ ...																

Weitere HM Sorten können Sie in der Sortenübersicht im Kapitel "Technische Hinweise" und der Preisliste finden.

Bestellbeispiel:
für rechte Ausführung und Sorte
R005M0100-10/AL41F

More carbide grades you can find in the grades summary in the chapter "technical instructions" and in the price list.

order-example:
righthand version and grade
R005M0100-10/AL41F

ULTRAMINI

Bohrungsbearbeitung
ab $\varnothing 0.2$ mm

grooving, boring and profiling
starting at $\varnothing 0.2$ mm

Typ 005M

Stechdrehen
mit Eckenradius

grooving
with corner radius

D min. 5.0 mm
Stechtiefe t max. 1.0 mm

D min. 5.0 mm
depth of groove t max. 1.0 mm

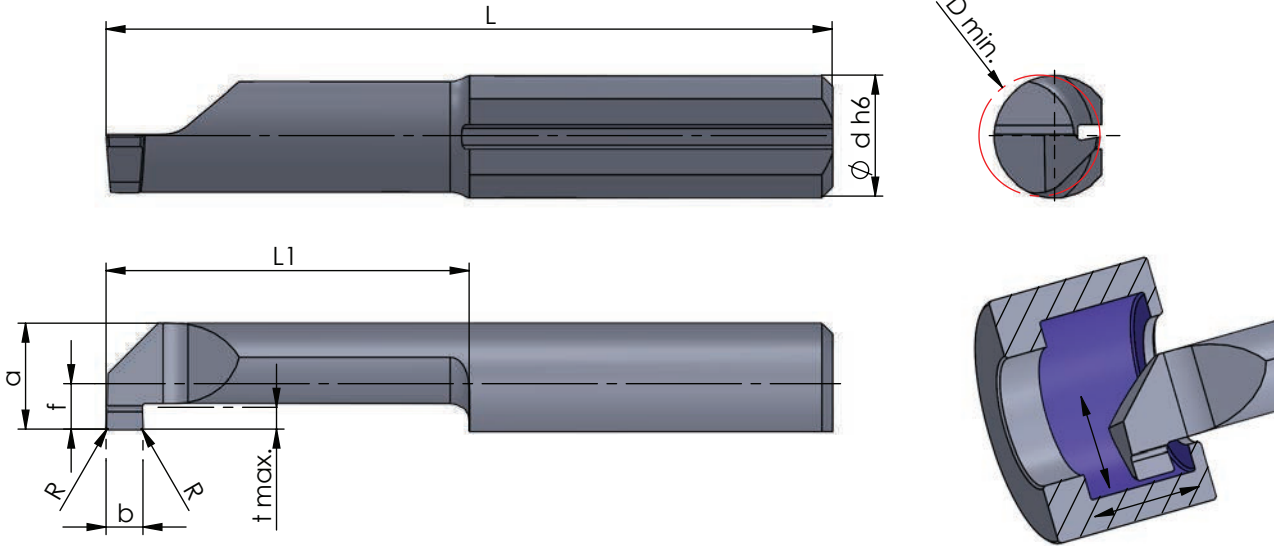

Rechts (R): wie gezeichnet
Links (L): spiegelbildlich

righthand (R): as shown
lefthand version (L): mirror image

Abmessungen in mm

dimensions in mm

Bestellnummer part number	b +0.05	b (inch)	R	f	a	L	L1	t max.	D min.	\varnothing d h6	Klemmhalter Typ toolholder type			
											K10F	CN45F	AL41F	P07C
R/L 005M0200-10	2.0	0.1	1.9	4.4	25	10	1.0	5.0	5.0		●			
R/L 005M0200-15	2.0	0.1	1.9	4.4	30	15	1.0	5.0	5.0		●			
R/L 005M0200-20	2.0	0.1	1.9	4.4	35	20	1.0	5.0	5.0		●			645... 650... ...5
R/L 005M0200-25	2.0	0.1	1.9	4.4	40	25	1.0	5.0	5.0		●			
R/L 005M0200-30	2.0	0.1	1.9	4.4	45	30	1.0	5.0	5.0		●			

Weitere HM Sorten können Sie in der Sortenübersicht im Kapitel "Technische Hinweise" und der Preisliste finden.

Bestellbeispiel:
für rechte Ausführung und Sorte
R005M0200-10/AL41F

More carbide grades you can find in the grades summary in the chapter "technical instructions" and in the price list.

order-example:
righthand version and grade
R005M0200-10/AL41F

ULTRAMINI

Bohrungsbearbeitung
ab \varnothing 0.2 mm

grooving, boring and profiling
starting at \varnothing 0.2 mm

Typ 006

Stechdrehen

grooving

D min. 6.0 mm
Stechtiefe t max. 1.8 mm
Auskragung (L1) bis 7x D

D min. 6.0 mm
depth of groove t max. 1.8 mm
overhang length (L1) up to 7x D

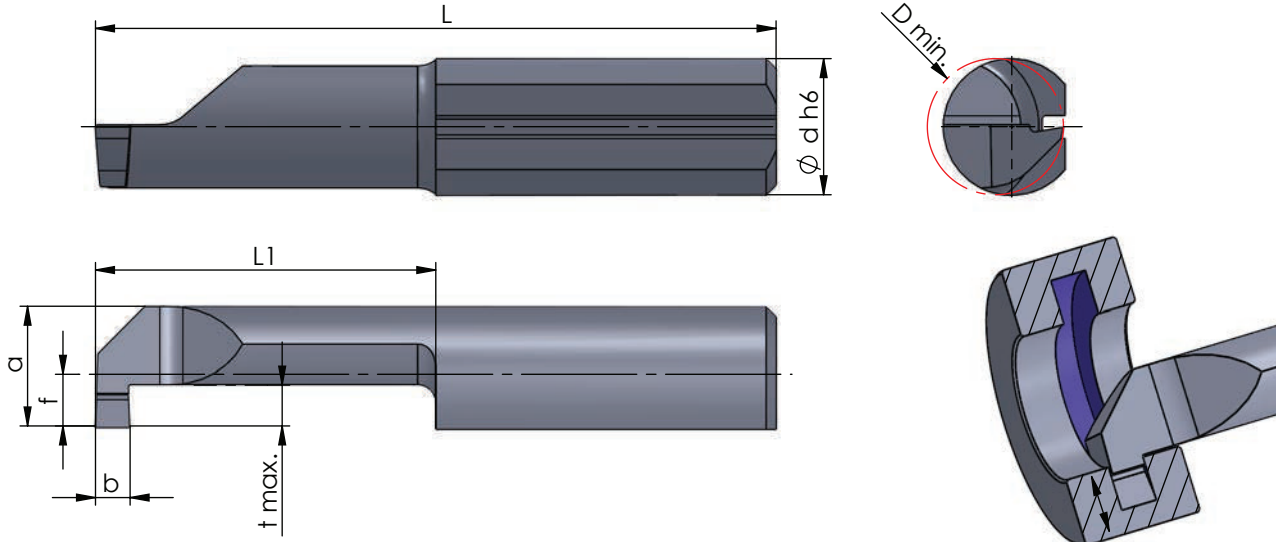

Rechts (R): wie gezeichnet
Links (L): spiegelbildlich

righthand (R): as shown
lefthand version (L): mirror image

Abmessungen in mm

dimensions in mm

Bestellnummer part number	b +0.05	f	a	L	L1	t max.	D min.	\varnothing d h6	K10F CN45F AL41F P07C	Klemmhalter Typ	toolholder type
										660... 676... ...6	
R/L 006.0100-10	1.0	2.3	5.3	25	10	1.8	6.0	6.0	● ●		
R/L 006.0100-15	1.0	2.3	5.3	30	15	1.8	6.0	6.0	● ●		
R/L 006.0100-22	1.0	2.3	5.3	37	22	1.8	6.0	6.0	● ●		
R/L 006.0100-25	1.0	2.3	5.3	40	25	1.8	6.0	6.0	● ●		
R/L 006.0100-30	1.0	2.3	5.3	45	30	1.8	6.0	6.0	● ●		
R/L 006.0100-35	1.0	2.3	5.3	50	35	1.8	6.0	6.0	● ●		
R/L 006.0100-42	1.0	2.3	5.3	57	42	1.8	6.0	6.0	●		
R/L 006.0150-10	1.5	2.3	5.3	25	10	1.8	6.0	6.0	● ●		
R/L 006.0150-15	1.5	2.3	5.3	30	15	1.8	6.0	6.0	● ●		
R/L 006.0150-22	1.5	2.3	5.3	37	22	1.8	6.0	6.0	● ●		
R/L 006.0150-25	1.5	2.3	5.3	40	25	1.8	6.0	6.0	● ●		
R/L 006.0150-30	1.5	2.3	5.3	45	30	1.8	6.0	6.0	● ●		
R/L 006.0150-35	1.5	2.3	5.3	50	35	1.8	6.0	6.0	● ●		
↳ ...											

Weitere HM Sorten können Sie in der Sortenübersicht im Kapitel "Technische Hinweise" und der Preisliste finden.

Bestellbeispiel:
für rechte Ausführung und Sorte
R006.0100-10/CN45F

More carbide grades you can find in the grades summary in the chapter "technical instructions" and in the price list.

order-example:
righthand version and grade
R006.0100-10/CN45F

ULTRAMINI

Bohrungsbearbeitung
ab $\varnothing 0.2 \text{ mm}$

grooving, boring and profiling
starting at $\varnothing 0.2 \text{ mm}$

Typ 006

Stechdrehen

grooving

D min. 6.0 mm
Stechtiefe t max. 1.8 mm
Auskrägung (L1) bis 7x D

D min. 6.0 mm
depth of groove t max. 1.8 mm
overhang length (L1) up to 7x D

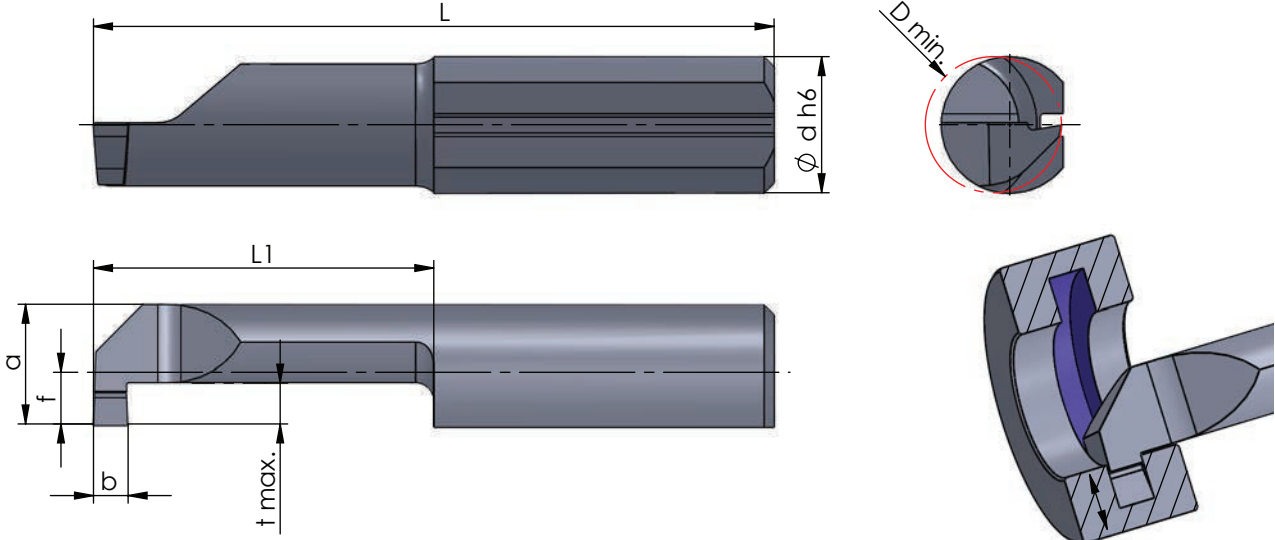

Rechts (R): wie gezeichnet
Links (L): spiegelbildlich

righthand (R): as shown
lefthand version (L): mirror image

Abmessungen in mm

dimensions in mm

Bestellnummer part number	b +0.05	f	a	L	L1	t max.	D min.	$\varnothing d h6$	Klemmhalter Typ				Klemmhalter Typ toolholder type
									K10F	CN45F	AL41F	P07C	
R/L 006.0200-10	2.0	2.3	5.3	25	10	1.8	6.0	6.0	●	●			660... 676... ...6
R/L 006.0200-15	2.0	2.3	5.3	30	15	1.8	6.0	6.0	●	●	●		
R/L 006.0200-22	2.0	2.3	5.3	37	22	1.8	6.0	6.0	●	●			
R/L 006.0200-25	2.0	2.3	5.3	40	25	1.8	6.0	6.0	●	●			
R/L 006.0200-30	2.0	2.3	5.3	45	30	1.8	6.0	6.0	●	●			

Weitere HM Sorten können Sie in der Sortenübersicht im Kapitel "Technische Hinweise" und der Preisliste finden.

Bestellbeispiel:
für rechte Ausführung und Sorte
R006.0200-10/CN45F

More carbide grades you can find in the grades summary in the chapter "technical instructions" and in the price list.

order-example:
righthand version and grade
R006.0200-10/CN45F

ULTRAMINI

Bohrungsbearbeitung
ab $\varnothing 0.2 \text{ mm}$

grooving, boring and profiling
starting at $\varnothing 0.2 \text{ mm}$

Typ 006M

Stechdrehen
mit Eckenradius

grooving
with corner radius

D min. 6.0 mm
Stechtiefe t max. 1.8 mm

D min. 6.0 mm
depth of groove t max. 1.8 mm

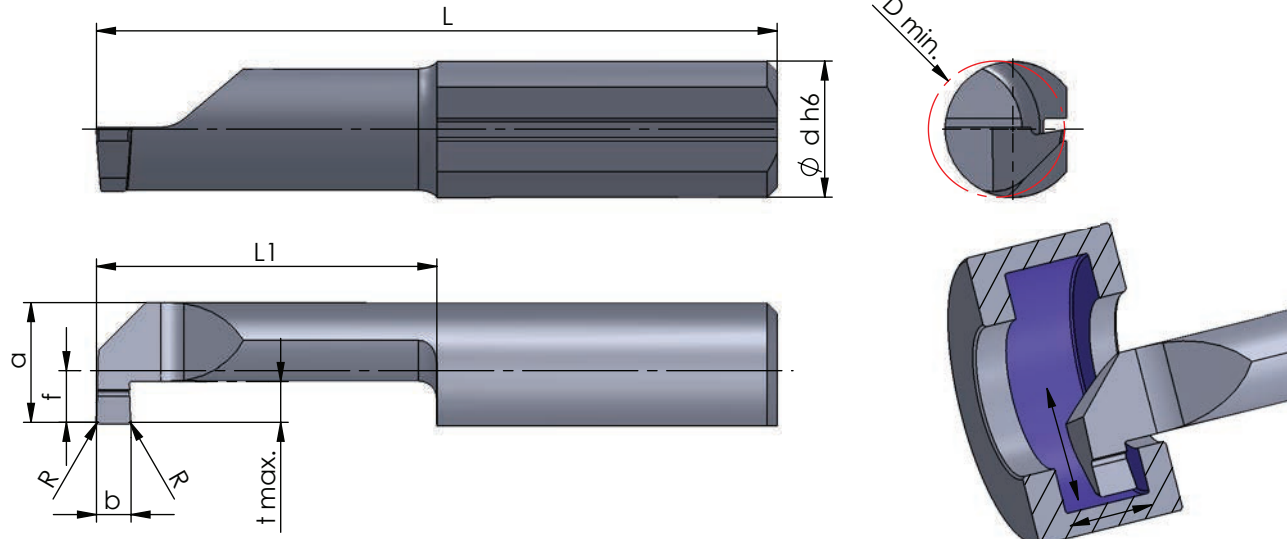

Rechts (R): wie gezeichnet
Links (L): spiegelbildlich

righthand (R): as shown
lefthand version (L): mirror image

Abmessungen in mm

dimensions in mm

Bestellnummer part number	b +0.05	b (inch)	R	f	a	L	L1	t max.	D min.	$\varnothing d h6$	Klemmhalter Typ				Klemmhalter Typ toolholder type
											K10F	CN45F	AL41F	PD2F	
R/L 006M0079-15	0.79	0.031"	0.1	2.3	5.3	30	15	1.8	6.0	6.0		●			660... 676... ...6
R/L 006M0100-10	1.0		0.1	2.3	5.3	25	10	1.8	6.0	6.0		●	●		
R/L 006M0100-15	1.0		0.1	2.3	5.3	30	15	1.8	6.0	6.0		●			
R/L 006M0100-22	1.0		0.1	2.3	5.3	37	22	1.8	6.0	6.0		●			
R/L 006M0100-25	1.0		0.1	2.3	5.3	40	25	1.8	6.0	6.0		●			
R/L 006M0100-30	1.0		0.1	2.3	5.3	45	30	1.8	6.0	6.0		●			
R/L 006M0117-15	1.17	0.046"	0.1	2.3	5.3	30	15	1.8	6.0	6.0		●			
R/L 006M0150-10	1.5		0.1	2.3	5.3	25	10	1.8	6.0	6.0		●			
R/L 006M0150-15	1.5		0.1	2.3	5.3	30	15	1.8	6.0	6.0		●			
R/L 006M0150-22	1.5		0.1	2.3	5.3	37	22	1.8	6.0	6.0		●			
R/L 006M0150-25	1.5		0.1	2.3	5.3	40	25	1.8	6.0	6.0		●			
R/L 006M0150-30	1.5		0.1	2.3	5.3	45	30	1.8	6.0	6.0		●			
↳ ...															

Weitere HM Sorten können Sie in der Sortenübersicht im Kapitel "Technische Hinweise" und der Preisliste finden.

Bestellbeispiel:
für rechte Ausführung und Sorte
R006M0100-10/AL41F

More carbide grades you can find in the grades summary in the chapter "technical instructions" and in the price list.

order-example:
righthand version and grade
R006M0100-10/AL41F

ULTRAMINI

Bohrungsbearbeitung
ab $\varnothing 0.2$ mm

grooving, boring and profiling
starting at $\varnothing 0.2$ mm

Typ 006M

Stechdrehen
mit Eckenradius

grooving
with corner radius

D min. 6.0 mm
Stechtiefe t max. 1.8 mm

D min. 6.0 mm
depth of groove t max. 1.8 mm

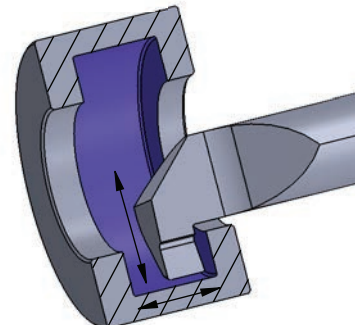
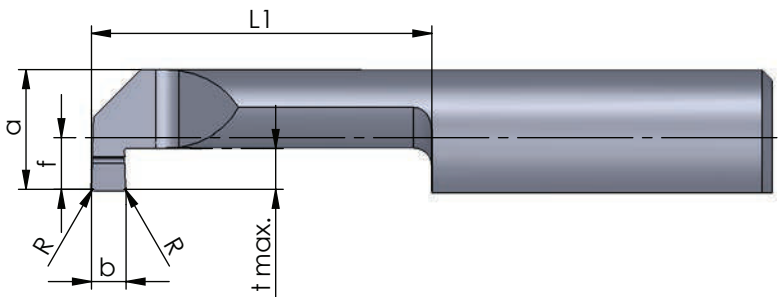
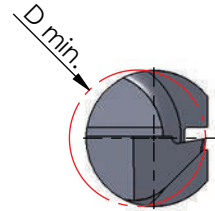
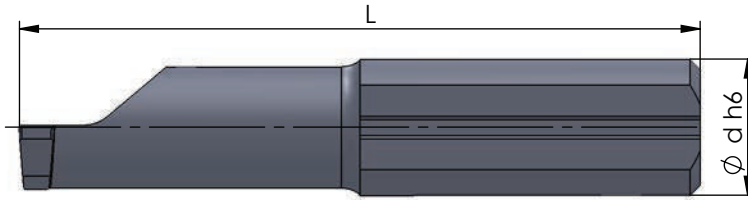

Rechts (R): wie gezeichnet
Links (L): spiegelbildlich

righthand (R): as shown
lefthand version (L): mirror image

Abmessungen in mm

dimensions in mm

Bestellnummer part number	b +0.05	b (inch)	R	f	a	L	L1	t max.	D min.	Ø d h6	Klemmhalter Typ				Klemmhalter Typ toolholder type
											K10F	CN45F	AL41F	PD2F	
⋮ ↓															
R/L 006M0198-15	1.98	0.078"	0.1	2.3	5.3	30	15	1.8	6.0	6.0		●			
R/L 006M0200-10	2.0		0.1	2.3	5.3	25	10	1.8	6.0	6.0		●			
R/L 006M0200-15	2.0		0.1	2.3	5.3	30	15	1.8	6.0	6.0		●			
R/L 006M0200-22	2.0		0.1	2.3	5.3	37	22	1.8	6.0	6.0		●			660... 676... ...6
R/L 006M0200-25	2.0		0.1	2.3	5.3	40	25	1.8	6.0	6.0		●			
R/L 006M0200-30	2.0		0.1	2.3	5.3	45	30	1.8	6.0	6.0		●			

Weitere HM Sorten können Sie in der Sortenübersicht im Kapitel "Technische Hinweise" und der Preisliste finden.

Bestellbeispiel:
für rechte Ausführung und Sorte
R006M0198-15/AL41F

More carbide grades you can find in the grades summary in the chapter "technical instructions" and in the price list.

order-example:
righthand version and grade
R006M0198-15/AL41F

ULTRAMINI

Bohrungsbearbeitung
ab \varnothing 0.2 mm

grooving, boring and profiling
starting at \varnothing 0.2 mm

Typ 007

Stechdrehen

grooving

D min. 6.8 mm
Stechtiefe t max. 2.5 mm
Auskragung (L1) bis 7x D

D min. 6.8 mm
depth of groove t max. 2.5 mm
overhang length (L1) up to 7x D

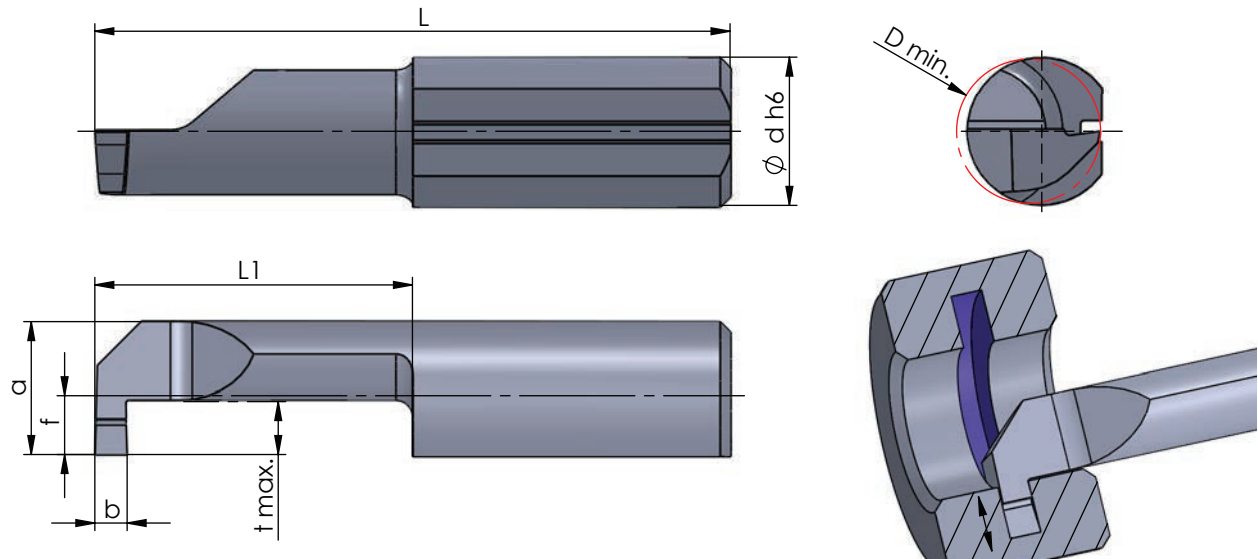

Rechts (R): wie gezeichnet
Links (L): spiegelbildlich

righthand (R): as shown
lefthand version (L): mirror image

Abmessungen in mm

dimensions in mm

Bestellnummer part number	b +0.05	b (inch)	f	a	L	L1	t max.	D min.	\varnothing d h6	Klemmhalter Typ				Klemmhalter Typ toolholder type
										K10F	CN45F	AL41F	PD2F	
R/L 007.0079-10	0.79	0.031"	2.8	6.3	25	10	2.5	6.8	7.0	●		●		670... 676... 687... ...7
R/L 007.0079-25	0.79	0.031"	2.8	6.3	40	25	2.5	6.8	7.0	●		●		
R/L 007.0100-10	1.0		2.8	6.3	25	10	2.5	6.8	7.0	●	●			
R/L 007.0100-15	1.0		2.8	6.3	30	15	2.5	6.8	7.0	●	●			
R/L 007.0100-22	1.0		2.8	6.3	37	22	2.5	6.8	7.0	●	●			
R/L 007.0100-25	1.0		2.8	6.3	40	25	2.5	6.8	7.0	●	●			
R/L 007.0100-30	1.0		2.8	6.3	45	30	2.5	6.8	7.0	●	●			
R/L 007.0100-35	1.0		2.8	6.3	50	35	2.5	7.0	7.0		●			
R/L 007.0100-40	1.0		2.8	6.3	55	40	2.5	7.0	7.0		●			
R/L 007.0100-45	1.0		2.8	6.3	60	45	2.5	7.0	7.0		●			
R/L 007.0100-50	1.0		2.8	6.3	65	50	2.5	7.0	7.0		●			
↳ ...														

Weitere HM Sorten können Sie in der Sortenübersicht im Kapitel "Technische Hinweise" und der Preisliste finden.

Bestellbeispiel:
für rechte Ausführung und Sorte
R007.0100-10/CN45F

More carbide grades you can find in the grades summary in the chapter "technical instructions" and in the price list.

order-example:
righthand version and grade
R007.0100-10/CN45F

ULTRAMINI

Bohrungsbearbeitung
ab Ø 0.2 mm

grooving, boring and profiling
starting at Ø 0.2 mm

Typ 007

Stechdrehen

D min. 6.8 mm
Stechtiefe t max. 2.5 mm

grooving

D min. 6.8 mm
depth of groove t max. 2.5 mm

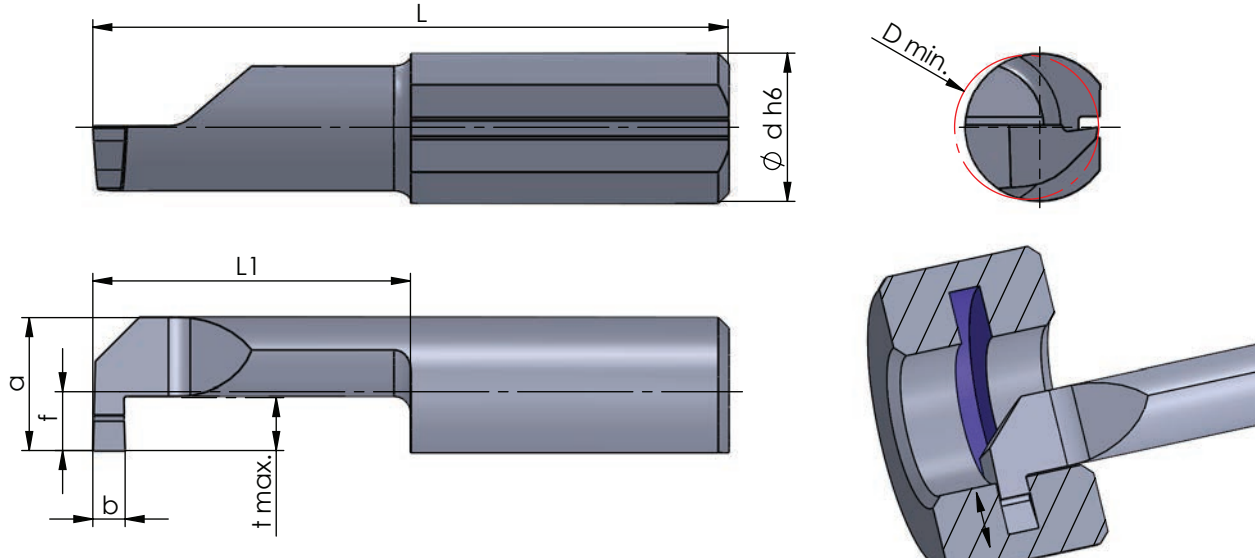

Rechts (R): wie gezeichnet
Links (L): spiegelbildlich

righthand (R): as shown
lefthand version (L): mirror image

Abmessungen in mm

dimensions in mm

Bestellnummer part number	b +0.05	b (inch)	f	a	L	L1	t max.	D min.	Ø d h6	Klemmhalter Typ				Klemmhalter Typ toolholder type
										K10F	CN45F	AL41F	PD2F	
...														
R/L 007.0150-10	1.5		2.8	6.3	25	10	2.5	6.8	7.0	●	●			670... 676... 687... ...7
R/L 007.0150-15	1.5		2.8	6.3	30	15	2.5	6.8	7.0	●	●			
R/L 007.0150-22	1.5		2.8	6.3	37	22	2.5	6.8	7.0	●	●			
R/L 007.0150-25	1.5		2.8	6.3	40	25	2.5	6.8	7.0	●	●			
R/L 007.0150-30	1.5		2.8	6.3	45	30	2.5	6.8	7.0	●	●			
R/L 007.0150-35	1.5		2.8	6.3	50	35	2.5	7.0	7.0		●	●		
R/L 007.0150-40	1.5		2.8	6.3	55	40	2.5	7.0	7.0		●	●		
R/L 007.0200-10	2.0		2.8	6.3	25	10	2.5	6.8	7.0	●	●			
R/L 007.0200-15	2.0		2.8	6.3	30	15	2.5	6.8	7.0	●	●			
R/L 007.0200-22	2.0		2.8	6.3	37	22	2.5	6.8	7.0	●	●			
R/L 007.0200-25	2.0		2.8	6.3	40	25	2.5	6.8	7.0	●	●			
R/L 007.0200-30	2.0		2.8	6.3	45	30	2.5	6.8	7.0	●	●	●		
R/L 007.0200-35	2.0		2.8	6.3	50	35	2.5	7.0	7.0	●	●	●		

Weitere HM Sorten können Sie in der Sortenübersicht im Kapitel "Technische Hinweise" und der Preisliste finden.

More carbide grades you can find in the grades summary in the chapter "technical instructions" and in the price list.

Bestellbeispiel:
für rechte Ausführung und Sorte
R007.0150-10/CN45F

order-example:
righthand version and grade
R007.0150-10/CN45F

ULTRAMINI

Bohrungsbearbeitung
ab \varnothing 0.2 mm

grooving, boring and profiling
starting at \varnothing 0.2 mm

Typ 007M

Stechdrehen
mit Eckenradius

grooving
with corner radius

D min. 6.8 mm
Stechtiefe t max. 2.5 mm

D min. 6.8 mm
depth of groove t max. 2.5 mm

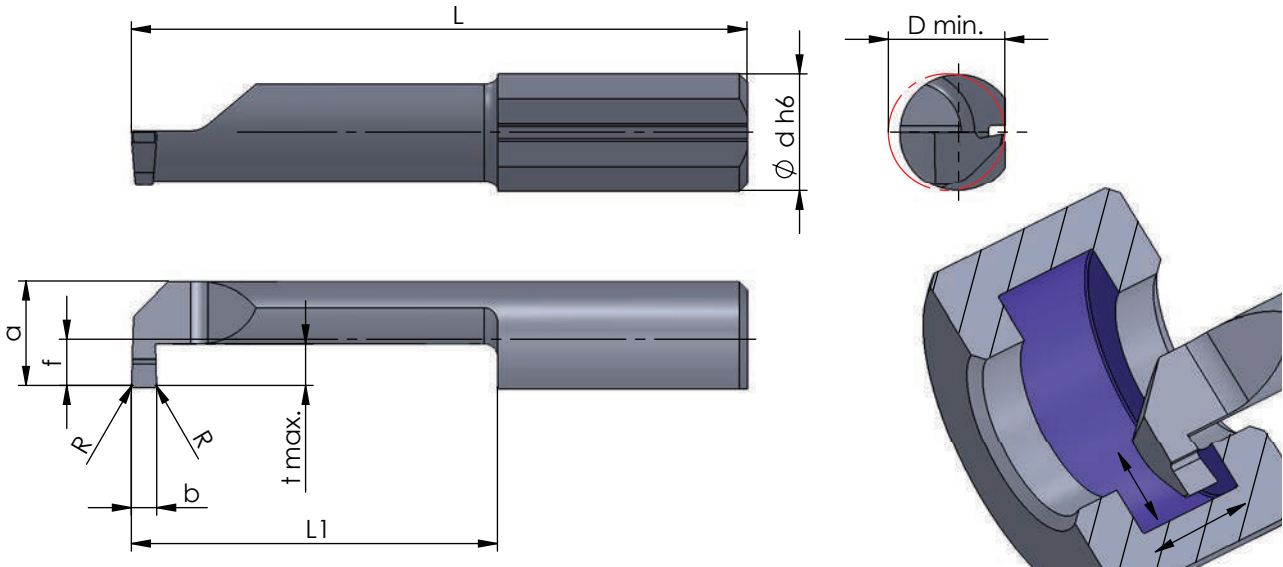

Rechts (R): wie gezeichnet
Links (L): spiegelbildlich

righthand (R): as shown
lefthand version (L): mirror image

Abmessungen in mm

dimensions in mm

Bestellnummer part number	b +0.05	b (inch)	R	f	a	L	L1	t max.	D min.	Ø d h6	Klemmhalter Typ				Klemmhalter Typ toolholder type	
											K10F	CN45F	AL41F	P07C		
R/L 007M0100-10	1.0		0.1	2.8	6.3	25	10	2.5	6.8	7.0		●			670... 676... 687... ...7	
R/L 007M0100-15	1.0		0.1	2.8	6.3	30	15	2.5	6.8	7.0		●				
R/L 007M0100-22	1.0		0.1	2.8	6.3	37	22	2.5	6.8	7.0		●				
R/L 007M0100-25	1.0		0.1	2.8	6.3	40	25	2.5	6.8	7.0		●				
R/L 007M0100-30	1.0		0.1	2.8	6.3	45	30	2.5	6.8	7.0		●				
R/L 007M0117-10	1.17	0.046"	0.1	2.8	6.3	25	10	2.5	6.8	7.0		●				
R/L 007M0117-22	1.17	0.046"	0.1	2.8	6.3	37	22	2.5	6.8	7.0		●				
R/L 007M0150-10	1.5		0.1	2.8	6.3	25	10	2.5	6.8	7.0		●				
R/L 007M0150-15	1.5		0.1	2.8	6.3	30	15	2.5	6.8	7.0		●				
R/L 007M0150-22	1.5		0.1	2.8	6.3	37	22	2.5	6.8	7.0		●				
R/L 007M0150-25	1.5		0.1	2.8	6.3	40	25	2.5	6.8	7.0		●				
R/L 007M0150-30	1.5		0.1	2.8	6.3	45	30	2.5	6.8	7.0		●				
R/L 007M0157-10	1.57	0.062"	0.1	2.8	6.3	25	10	2.5	6.8	7.0		●				
R/L 007M0157-25	1.57	0.062"	0.1	2.8	6.3	40	25	2.5	6.8	7.0		●				
↳ ...																

Weitere HM Sorten können Sie in der Sortenübersicht im Kapitel "Technische Hinweise" und der Preisliste finden.

Bestellbeispiel:
für rechte Ausführung und Sorte
R007M0100-10/AL41F

More carbide grades you can find in the grades summary in the chapter "technical instructions" and in the price list.

order-example:
righthand version and grade
R007M0100-10/AL41F

ULTRAMINI

Bohrungsbearbeitung
ab \varnothing 0.2 mm

grooving, boring and profiling
starting at \varnothing 0.2 mm

Typ 007M

Stechdrehen
mit Eckenradius

grooving
with corner radius

D min. 6.8 mm
Stechtiefe t max. 2.5 mm

D min. 6.8 mm
depth of groove t max. 2.5 mm

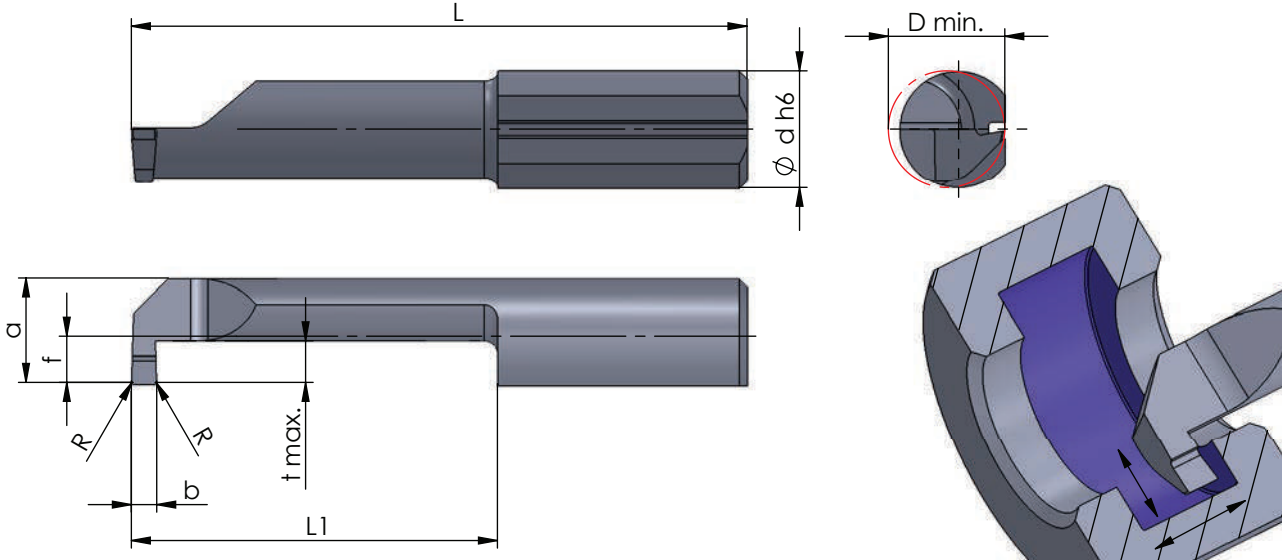

Rechts (R): wie gezeichnet
Links (L): spiegelbildlich

righthand (R): as shown
lefthand version (L): mirror image

Abmessungen in mm

dimensions in mm

Bestellnummer part number	b +0.05	b (inch)	R	f	a	L	L1	t max.	D min.	Ø d h6	Klemmhalter Typ				Klemmhalter Typ	toolholder type
											K10F	CN45F	AL41F	P07C		
...																
R/L 007M0198-22	1.98	0.078"	0.1	2.8	6.3	37	22	2.5	6.8	7.0		●				
R/L 007M0200-10	2.0		0.1	2.8	6.3	25	10	2.5	6.8	7.0		●				
R/L 007M0200-15	2.0		0.1	2.8	6.3	30	15	2.5	6.8	7.0		●				
R/L 007M0200-22	2.0		0.1	2.8	6.3	37	22	2.5	6.8	7.0		●				670... 676... 687... ...7
R/L 007M0200-25	2.0		0.1	2.8	6.3	40	25	2.5	6.8	7.0		●				
R/L 007M0200-30	2.0		0.1	2.8	6.3	45	30	2.5	6.8	7.0		●				

Weitere HM Sorten können Sie in der Sortenübersicht im Kapitel "Technische Hinweise" und der Preisliste finden.

More carbide grades you can find in the grades summary in the chapter "technical instructions" and in the price list.

Bestellbeispiel:
für rechte Ausführung und Sorte
R007M0200-10/AL41F

order-example:
righthand version and grade
R007M0200-10/AL41F

ULTRAMINI

Bohrungsbearbeitung
ab \varnothing 0.2 mm

grooving, boring and profiling
starting at \varnothing 0.2 mm

Typ 008M

Stechdrehen
mit Eckenradius

grooving
with corner radius

D min. 7.8 mm
Stechtiefe t max. 3.0 mm

D min. 7.8 mm
depth of groove t max. 3.0 mm

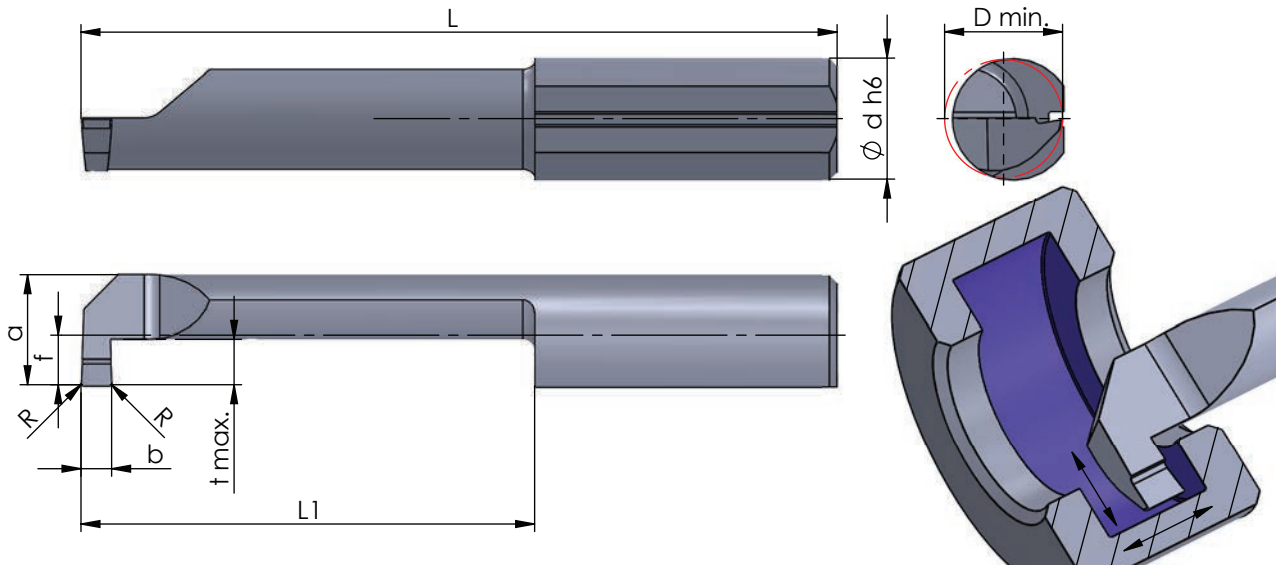

Rechts (R): wie gezeichnet
Links (L): spiegelbildlich

righthand (R): as shown
lefthand version (L): mirror image

Abmessungen in mm

dimensions in mm

Bestellnummer part number	b +0.05	R	f	a	L	L1	t max.	D min.	Ø d h6	Klemmhalter Typ toolholder type			
										K10F	CN45F	AL41F	P07C
R/L 008M0100-30	1.0	0.1	3.3	7.3	50	30	3.0	7.8	8.0		●		
R/L 008M0100-40	1.0	0.1	3.3	7.3	60	40	3.0	7.8	8.0		●		
R/L 008M0200-30	2.0	0.1	3.3	7.3	50	30	3.0	7.8	8.0		●		680... 681... 687... ...8
R/L 008M0200-40	2.0	0.1	3.3	7.3	60	40	3.0	7.8	8.0		●		
R/L 008M0250-30	2.5	0.1	3.3	7.3	50	30	3.0	7.8	8.0		●		
R/L 008M0250-40	2.5	0.1	3.3	7.3	60	40	3.0	7.8	8.0		●		

Weitere HM Sorten können Sie in der Sortenübersicht im Kapitel "Technische Hinweise" und der Preisliste finden.

Bestellbeispiel:
für rechte Ausführung und Sorte
R008M0100-30/AL41F

More carbide grades you can find in the grades summary in the chapter "technical instructions" and in the price list.

order-example:
righthand version and grade
R008M0100-30/AL41F

ULTRAMINI

Bohrungsbearbeitung
ab $\varnothing 0.2 \text{ mm}$

grooving, boring and profiling
starting at $\varnothing 0.2 \text{ mm}$

Typ 10M

Stechdrehen
mit Eckenradius und
innerer Kühlmittelzufuhr

grooving
with corner radius and
with through coolant

D min. 10.5 mm
Stechtiefe t max. 4.0 mm

D min. 10.5 mm
depth of groove t max. 4.0 mm

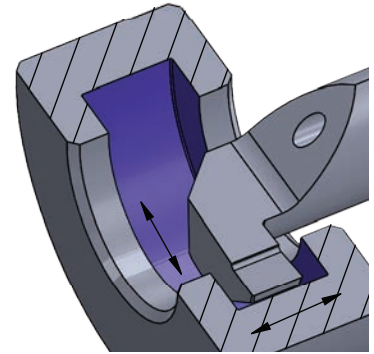
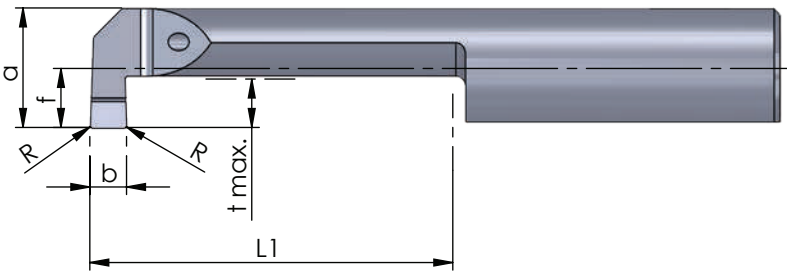
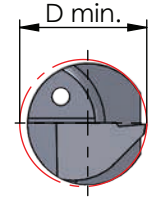
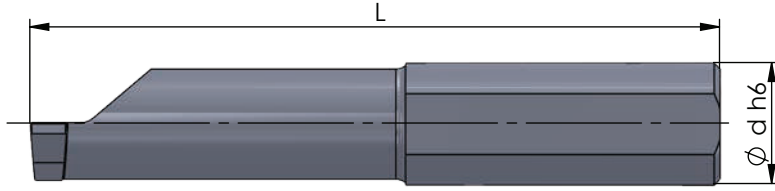

Rechts (R): wie gezeichnet
Links (L): spiegelbildlich

righthand (R): as shown
lefthand version (L): mirror image

Abmessungen in mm

dimensions in mm

	Bestellnummer part number	b +0.05	R	f	a	L	L1	t max.	D min.	$\varnothing d h6$					Klemmhalter Typ toolholder type
											K10F	CN45F	AL41F	P07C	
neu	R/L 10M0100-30	1.0	0.1	4.9	9.9	57	30	4.0	10.5	10		●			681...
neu	R/L 10M0100-50	1.0	0.1	4.9	9.9	77	50	4.0	10.5	10		●			
neu	R/L 10M0200-30	2.0	0.1	4.9	9.9	57	30	4.0	10.5	10		●			
neu	R/L 10M0200-50	2.0	0.1	4.9	9.9	77	50	4.0	10.5	10		●			
neu	R/L 10M0300-30	3.0	0.1	4.9	9.9	57	30	4.0	10.5	10		●			
neu	R/L 10M0300-50	3.0	0.1	4.9	9.9	77	50	4.0	10.5	10		●			

Weitere HM Sorten können Sie in der Sortenübersicht im Kapitel "Technische Hinweise" und der Preisliste finden.

Bestellbeispiel:
für rechte Ausführung und Sorte
R10M0100-30/AL41F

More carbide grades you can find in the grades summary in the chapter "technical instructions" and in the price list.

order-example:
righthand version and grade
R10M0100-30/AL41F

ULTRAMINI

Bohrungsbearbeitung
ab \varnothing 0.2 mm

grooving, boring and profiling
starting at \varnothing 0.2 mm

Typ 004 / 005 / 006 / 007

Stechdrehen und Kopieren
mit Vollradius

grooving and profiling
with full radius

D min. 4.0 mm
Vollradius R 0.5 - 1.0

D min. 4.0 mm
full radius R 0.5 - 1.0

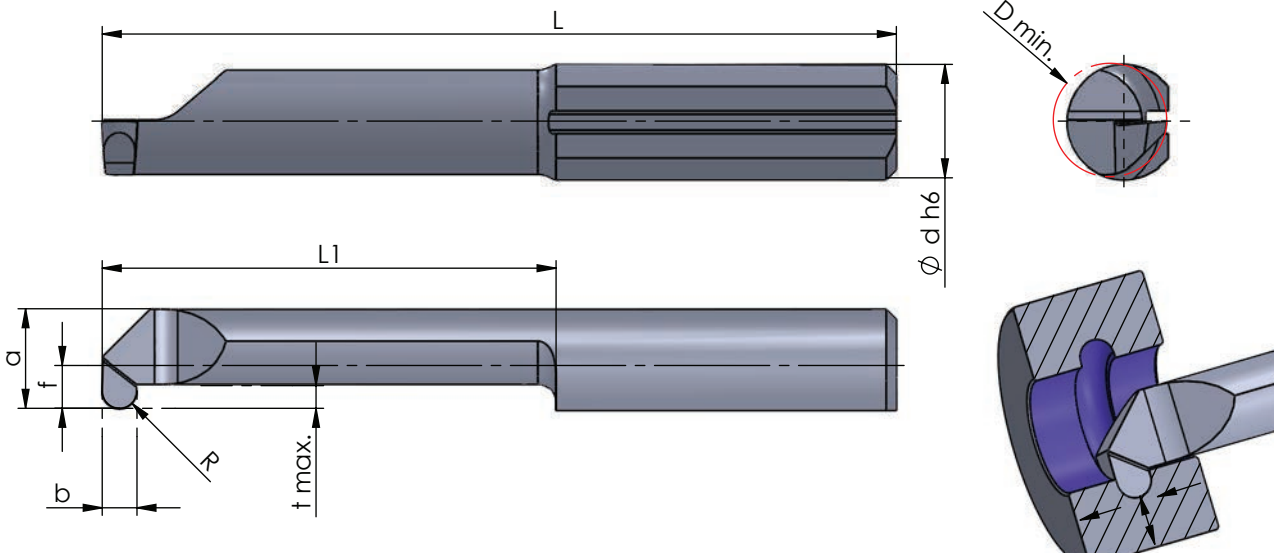

Rechts (R): wie gezeichnet
Links (L): spiegelbildlich

righthand (R): as shown
lefthand version (L): mirror image

Abmessungen in mm

dimensions in mm

Bestellnummer part number	b +0.05	b (inch)	R	f	a	L	L1	t max.	D min.	Ø d h6	K10F CN45F AL41F PD2F	Klemmhalter Typ toolholder type
	R/L004-0.50-16	1.0		0.5	1.5	3.5	30	16	0.8	4.0		
R/L005-0.50-20	1.0		0.5	1.9	4.4	35	20	1.0	5.0	5.0	●	645... 650... ...5
R/L005-0.58-20	1.17	0.046"	0.585	1.9	4.4	35	20	1.0	5.0	5.0	●	650... ...5
R/L005-0.75-20	1.5		0.75	1.9	4.4	35	20	1.0	5.0	5.0	●	650... ...5
R/L005-1.00-20	2.0		1.0	1.9	4.4	35	20	1.0	5.0	5.0	●	650... ...5
R/L006-0.50-25	1.0		0.5	2.3	5.3	40	25	1.8	6.0	6.0	● ● ●	660... ...6
R/L006-0.75-25	1.5		0.75	2.3	5.3	40	25	1.8	6.0	6.0	● ● ●	660... ...6
R/L006-1.00-25	2.0		1.0	2.3	5.3	40	25	1.8	6.0	6.0	● ● ●	660... ...6
R/L007-0.50-30	1.0		0.5	2.8	6.3	45	30	2.5	6.8	7.0	●	670... 687... ...7
R/L007-0.75-30	1.5		0.75	2.8	6.3	45	30	2.5	6.8	7.0	●	670... 687... ...7
R/L007-1.00-30	2.0		1.0	2.8	6.3	45	30	2.5	6.8	7.0	●	670... 687... ...7

Weitere HM Sorten können Sie in der Sortenübersicht im Kapitel "Technische Hinweise" und der Preisliste finden.

Bestellbeispiel:
für rechte Ausführung und Sorte
R004-0.50-16/CN45F

More carbide grades you can find in the grades summary in the chapter "technical instructions" and in the price list.

order-example:
righthand version and grade
R004-0.50-16/CN45F

ULTRAMINI

Bohrungsbearbeitung
ab \varnothing 0.2 mm

grooving, boring and profiling
starting at \varnothing 0.2 mm

Typ 060

Audreihen und Fasen

D min. 3.0 - 6.8 mm

boring and chamfering

D min. 3.0 - 6.8 mm

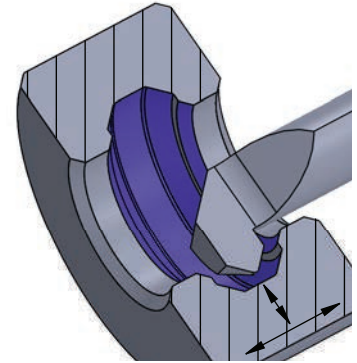
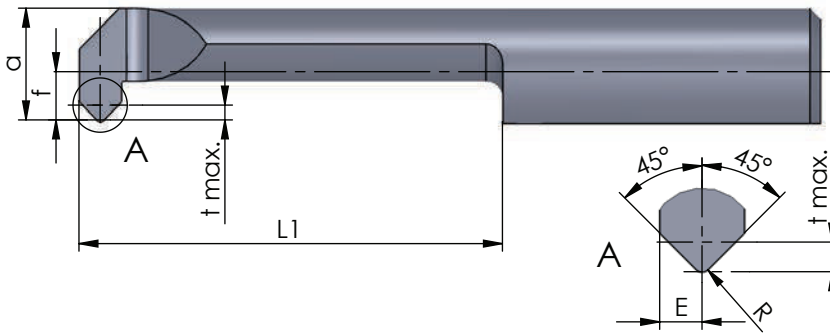
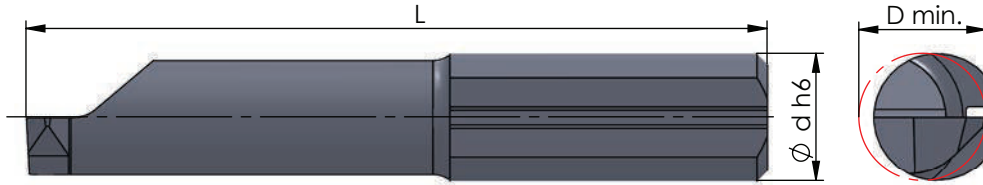

Rechts (R): wie gezeichnet
Links (L): spiegelbildlich

righthand (R): as shown
lefthand version (L): mirror image

Abmessungen in mm

dimensions in mm

Bestellnummer part number	E	R	f	a	L	L1	t max.	D min.	Ø d h6	K10F	CN45F	AL41F	P07C	Klemmhalter Typ	toolholder type
R/L 060.3-10	1	0.2	0.7	2.7	24	10	0.4	3.0	4	●	●			645...	640... ...4
R/L 060.4-16	1	0.2	1.5	3.5	30	16	0.5	4.0	4	●	●				650... ...5
R/L 060.5-15	1	0.2	1.9	4.4	30	15	0.7	5.0	5	●	●			676...	660... ...6
R/L 060.5-20	1	0.2	1.9	4.4	35	20	0.7	5.0	5	●	●				670... 687... ...7
R/L 060.6-20	1	0.2	2.3	5.3	35	20	0.7	6.0	6	●	●				
R/L 060.6-25	1	0.2	2.3	5.3	40	25	0.7	6.0	6	●	●				
R/L 060.7-20	1	0.2	2.8	6.3	35	20	0.7	6.8	7	●	●				
R/L 060.7-40	1	0.2	2.8	6.3	55	40	0.7	6.8	7	●	●				

Weitere HM Sorten können Sie in der Sortenübersicht im Kapitel "Technische Hinweise" und der Preisliste finden.

Bestellbeispiel:
für rechte Ausführung und Sorte
R060.5-15/CN45F

More carbide grades you can find in the grades summary in the chapter "technical instructions" and in the price list.

order-example:
righthand version and grade
R060.5-15/CN45F

ULTRAMINI

Bohrungsbearbeitung
ab $\varnothing 0.2 \text{ mm}$

grooving, boring and profiling
starting at $\varnothing 0.2 \text{ mm}$

Typ 070

Vorstechen und Fasen

D min. 4.0 - 6.0 mm

pregrooving and chamfering

D min. 4.0 - 6.0 mm

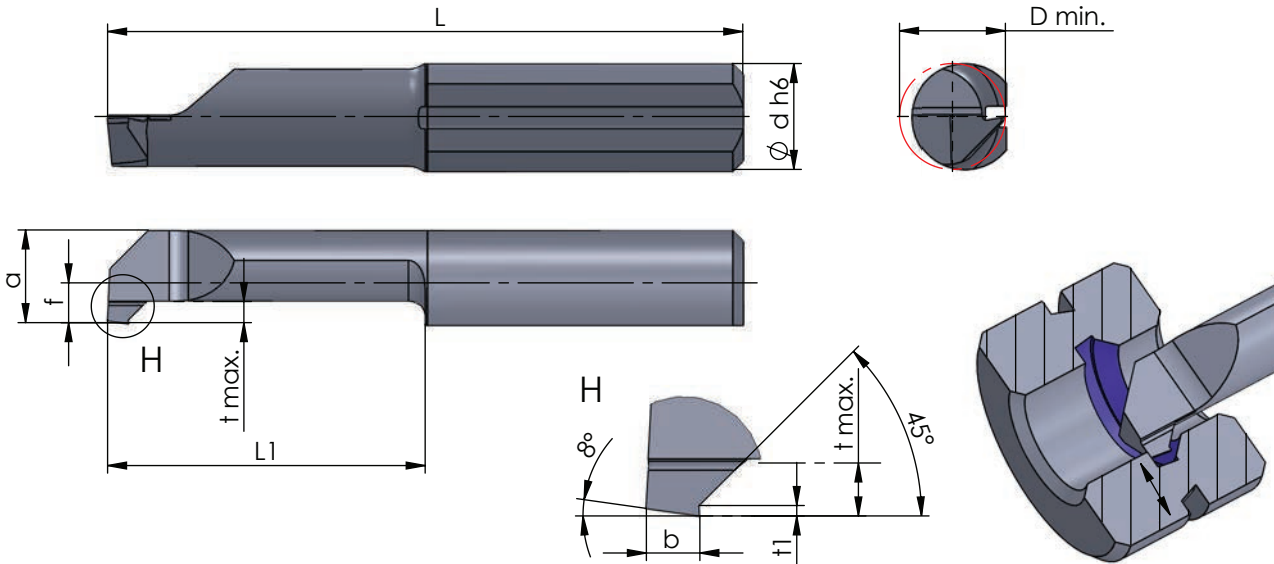

Rechts (R): wie gezeichnet
Links (L): spiegelbildlich

righthand (R): as shown
lefthand version (L): mirror image

Abmessungen in mm

dimensions in mm

Bestellnummer part number	b	f	a	L	L1	t max.	D min.	$\varnothing d h6$	K10F CN45F AL41F P07C	Klemmhalter Typ toolholder type	
										645...	640... ...4 650... ...5
R/L 070.4-10	1.0	1.5	3.5	25	10	0.8	4.0	4.0	● ●	645...	640... ...4
R/L 070.4-16	1.0	1.5	3.5	30	16	0.8	4.0	4.0	● ●		640... ...4
R/L 070.5-15	1.0	1.9	4.4	30	15	1.0	5.0	5.0	● ●	645...	650... ...5
R/L 070.5-20	1.0	1.9	4.4	35	20	1.0	5.0	5.0	● ●		
R/L 070.5-30	1.0	1.9	4.4	45	30	1.0	5.0	5.0	● ●		
R/L 070.6-30	1.0	2.3	5.3	45	30	1.0	6.0	6.0	● ●	660... 676... ...6	
R/L 070.6-42	1.0	2.3	5.3	57	42	1.0	6.0	6.0	● ●		

Weitere HM Sorten können Sie in der Sortenübersicht im Kapitel "Technische Hinweise" und der Preisliste finden.

Bestellbeispiel:
für rechte Ausführung und Sorte
R070.4-10/CN45F

More carbide grades you can find in the grades summary in the chapter "technical instructions" and in the price list.

order-example:
righthand version and grade
R070.4-10/CN45F

ULTRAMINI

Bohrungsbearbeitung
ab \varnothing 0.2 mm

grooving, boring and profiling
starting at \varnothing 0.2 mm

Impressionen

impressions

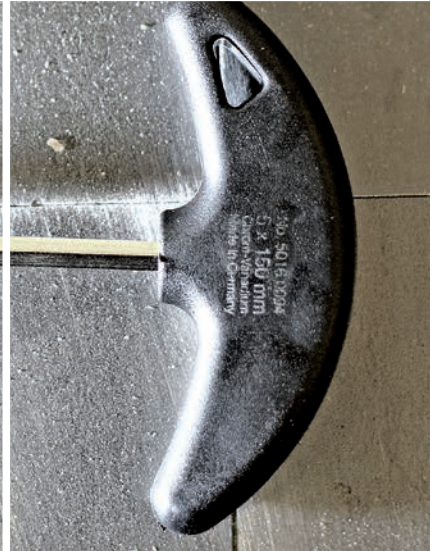
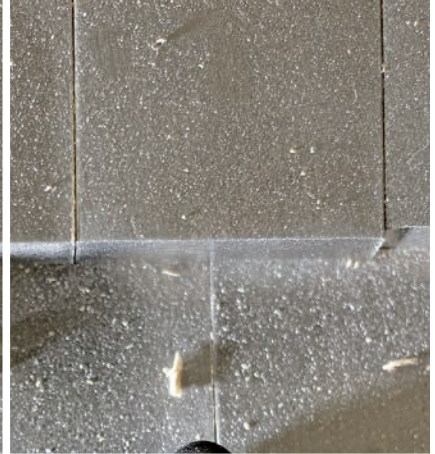

ULTRAMINI

Bohrungsbearbeitung
ab \varnothing 0.2 mm

grooving, boring and profiling
starting at \varnothing 0.2 mm

Typ Gewindedrehen

metrisches ISO-Gewinde,
Teilprofil, innen

type threading,
metric ISO-thread,
partial profile, internal

D min. 1.56 - 7.0 mm
Steigung P = 0.4 - 1.75

D min. 1.56 - 7.0 mm
pitch P = 0.4 - 1.75

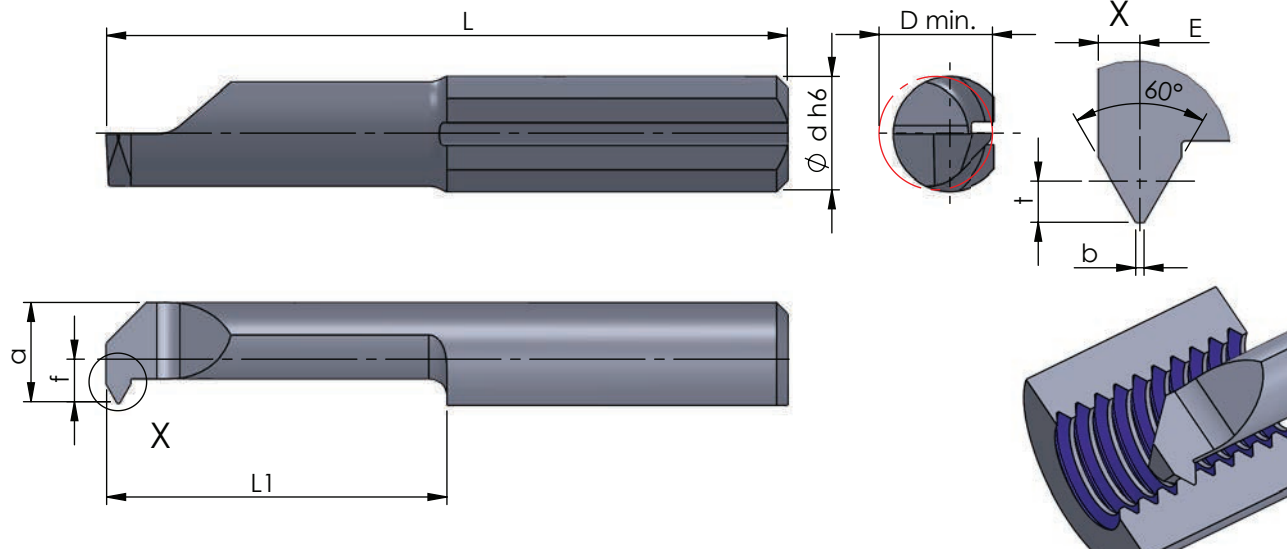

Rechts (R): wie gezeichnet
Links (L): spiegelbildlich

righthand (R): as shown
lefthand version (L): mirror image

Abmessungen in mm

dimensions in mm

Bestellnummer part number	Steigung P pitch P	Regelgewinde / standard thread									D min.	\varnothing d h6	Klemmhalter Typ				Klemmhalter Typ toolholder type
			t	E	b	f	a	L	L1	K10F			CN45F	AL41F	PD2F		
R/L 002.0204-5	0.4 - 0.45	M2	0.22	0.2	0.05		1.4	20	5	1.56	4.0		●				645... 640... ...4
R/L 002.02045-6	0.45 - 0.5	M2.5	0.24	0.22	0.06		1.45	22	6	1.7	4.0		●				
R/L 003.0105-8	0.5 - 0.7	M3	0.27	0.33	0.04	0.3	2.3	22	8	2.4	4.0		●				
R/L 004.0105-10	0.5 - 0.75		0.27	0.44	0.09	1.0	3.0	24	10	3.2	4.0		●				
R/L 004.0307-10	0.7 - 0.8	M4	0.32	0.32	0.09	0.9	2.9	24	10	3.2	4.0		●				
R/L 004.0205-15	0.5 - 0.75		0.27	0.35	0.06	1.5	3.5	30	15	4.0	4.0	●	●				
R/L 004.0408-15	0.8 - 1.0	M5	0.43	0.45	0.10	1.5	3.5	30	15	4.0	4.0		●			650... ...5	
R/L 005.0205-15	0.5 - 0.75		0.27	0.35	0.06	1.9	4.4	30	15	5.0	5.0	●	●				
R/L 005.0205-20	0.5 - 0.75		0.27	0.35	0.06	1.9	4.4	35	20	5.0	5.0	●	●				
R/L 005.0407-15	0.75 - 1.0		0.4	0.45	0.09	1.9	4.4	30	15	5.0	5.0	●	●				
R/L 005.0407-20	0.75 - 1.0		0.4	0.45	0.09	1.9	4.4	35	20	5.0	5.0	●	●				
R/L 005.0510-15	1.0 - 1.25	M6	0.55	0.55	0.12	1.9	4.4	30	15	5.0	5.0	●	●				
R/L 005.0510-20	1.0 - 1.25	M6	0.55	0.55	0.12	1.9	4.4	35	20	5.0	5.0	●	●				
L → ...																	

Weitere HM Sorten können Sie in der Sortenübersicht im Kapitel "Technische Hinweise" und der Preisliste finden.

Bestellbeispiel:
für rechte Ausführung und Sorte
R002.0204-5/AL41F

weitere Informationen:
• siehe Technische Hinweise

more informations:
• look at the technical instructions

More carbide grades you can find in the grades summary in the chapter "technical instructions" and in the price list.

order-example:
righthand version and grade
R002.0204-5/AL41F

ULTRAMINI

Bohrungsbearbeitung
ab $\varnothing 0.2$ mm

grooving, boring and profiling
starting at $\varnothing 0.2$ mm

Typ Gewindedrehen

metrisches ISO-Gewinde,
Teilprofil, innen

type threading,
metric ISO-thread,
partial profile, internal

D min. 1.56 - 7.0 mm
Steigung P = 0.4 - 1.75

D min. 1.56 - 7.0 mm
pitch P = 0.4 - 1.75

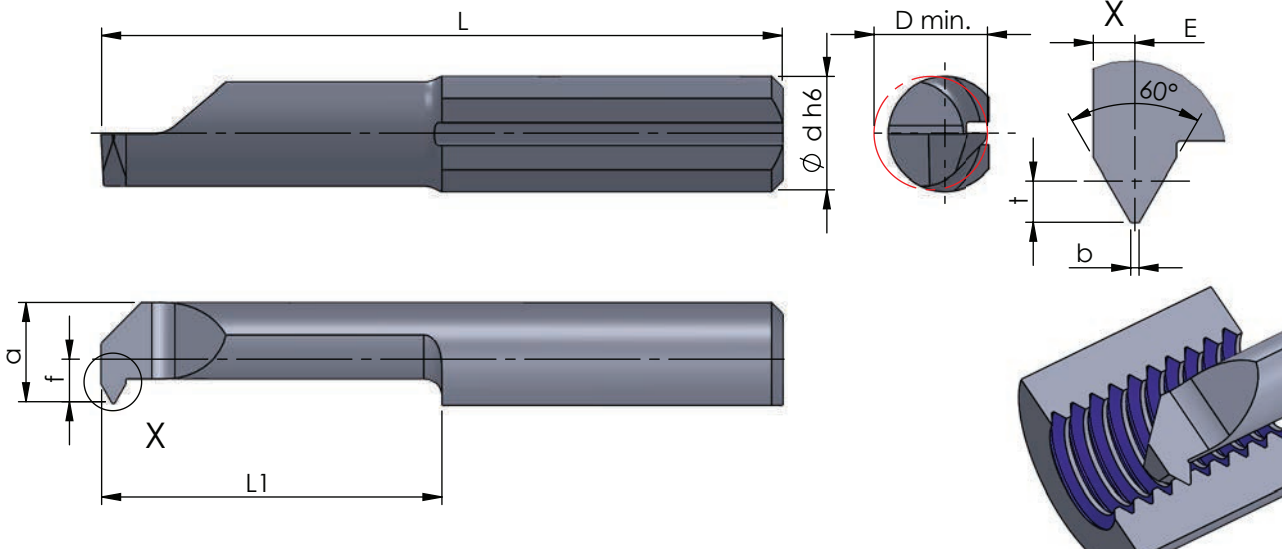

Rechts (R): wie gezeichnet
Links (L): spiegelbildlich

righthand (R): as shown
lefthand version (L): mirror image

Abmessungen in mm

dimensions in mm

Bestellnummer part number	Steigung P pitch P	Regelgewinde / standard thread	t	E	b	f	a	L	L1	D min.	\varnothing d h6	Klemmhalter Typ				Klemmhalter Typ toolholder type
												K10F	CN45F	AL41F	PD2F	
...																
R/L 006.0510-15	1.0 - 1.25		0.55	0.55	0.12	2.3	5.3	30	15	6.0	6.0	●	●			
R/L 006.0510-22	1.0 - 1.25		0.55	0.55	0.12	2.3	5.3	37	22	6.0	6.0	●	●			
R/L 006.0612-15	1.25 - 1.5	M8	0.68	0.65	0.15	2.3	5.3	30	15	6.0	6.0	●	●			
R/L 006.0612-22	1.25 - 1.5	M8	0.68	0.65	0.15	2.3	5.3	37	22	6.0	6.0	●				660... ...6
R/L 006.0815-15	1.5 - 1.75	M10	0.81	0.75	0.18	2.3	5.3	30	15	6.0	6.0	●	●			
R/L 006.0815-22	1.5 - 1.75	M10	0.81	0.75	0.18	2.3	5.3	37	22	6.0	6.0	●	●			
R/L 007.0815-15	1.5 - 1.75	M10	0.81	0.75	0.18	2.7	6.3	30	15	7.0	7.0	●	●			
R/L 007.0815-25	1.5 - 1.75	M10	0.81	0.75	0.18	2.7	6.3	40	25	7.0	7.0	●				670... 687... ...7

Weitere HM Sorten können Sie in der Sortenübersicht im Kapitel "Technische Hinweise" und der Preisliste finden.

Bestellbeispiel:
für rechte Ausführung und Sorte
R006.0510-15/AL41F

weitere Informationen:

- siehe Technische Hinweise

more informations:

- look at the technical instructions

More carbide grades you can find in the grades summary in the chapter "technical instructions" and in the price list.

order-example:
righthand version and grade
R006.0510-15/AL41F

ULTRAMINI

Bohrungsbearbeitung
ab $\varnothing 0.2$ mm

grooving, boring and profiling
starting at $\varnothing 0.2$ mm

Typ Gewindedrehen

metrisches ISO-Gewinde,
Vollprofil, innen

type threading,
metric ISO-thread,
full profile, internal

D min. 4.0 - 7.0 mm
Steigung P = 0.5 - 1.5

D min. 4.0 - 7.0 mm
pitch P = 0.5 - 1.5

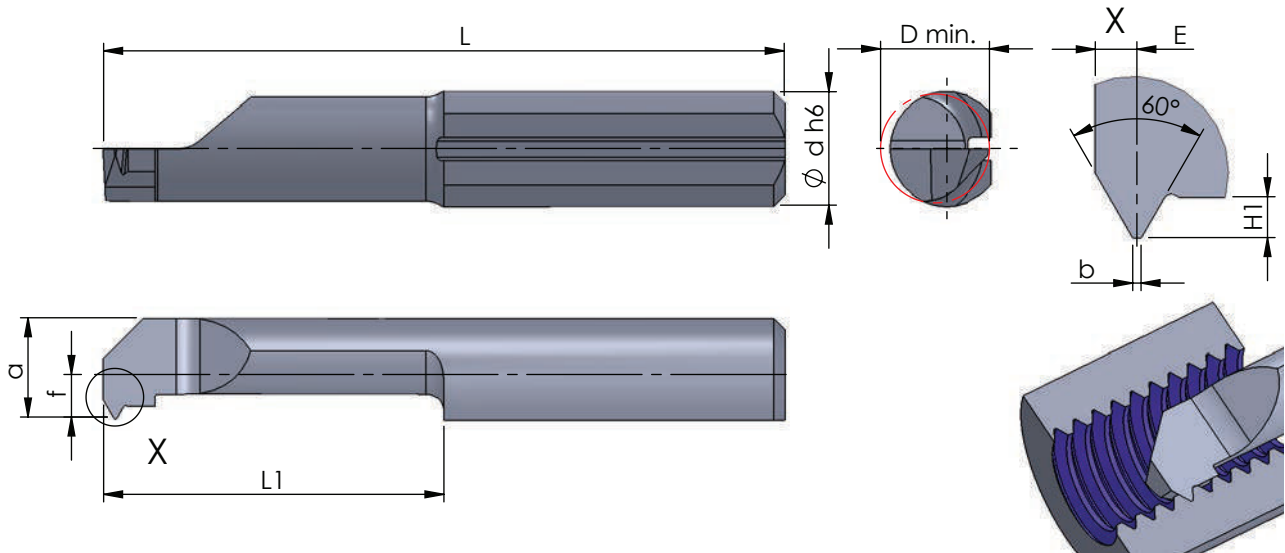

Rechts (R): wie gezeichnet
Links (L): spiegelbildlich

righthand (R): as shown
lefthand version (L): mirror image

Abmessungen in mm

dimensions in mm

Bestellnummer part number	Steigung P pitch P	Regelgewinde / standard thread	H1	E	b	f	a	L	L1	D min.	\varnothing d h6	Klemmhalter Typ				Klemmhalter Typ	toolholder type
												K10F	CN45F	AL41F	PD2F		
R/L 104.0205-15	0.5		0.27	0.35	0.06	1.5	3.5	30	15	4.0	4.0						640... ...4
R/L 104.0408-15	0.8	M5	0.43	0.5	0.1	1.5	3.5	30	15	4.0	4.0						640... ...4
R/L 105.0205-15	0.5		0.27	0.35	0.06	1.9	4.4	30	15	5.0	5.0				645...		640... ...4
R/L 105.0407-15	0.75		0.40	0.45	0.09	1.9	4.4	30	15	5.0	5.0				645...		640... ...4
R/L 105.0408-15	0.8		0.43	0.50	0.10	1.9	4.4	30	15	4.8	5.0				645...		650... ...5
R/L 105.0510-15	1.0	M6	0.54	0.55	0.12	1.9	4.4	30	15	4.8	5.0				645...		650... ...5
R/L 106.0510-15	1.0		0.54	0.55	0.12	2.3	5.3	30	15	6.0	6.0				676...		660... ...6
R/L 106.0612-15	1.25	M8	0.67	0.65	0.15	2.3	5.3	30	15	6.0	6.0				676...		660... ...6
R/L 106.0815-15	1.5	M10	0.81	0.75	0.18	2.3	5.3	30	15	6.0	6.0				676...		660... ...6
R/L 107.0815-15	1.5	M10	0.81	0.75	0.18	2.8	6.3	30	15	7.0	7.0				676...		670... 687... ...7

Weitere HM Sorten können Sie in der Sortenübersicht im Kapitel "Technische Hinweise" und der Preisliste finden.

Bestellbeispiel:
für rechte Ausführung und Sorte
R104.0205-15/AL41F

weitere Informationen:
• siehe Technische Hinweise

more informations:
• look at the technical instructions

More carbide grades you can find in the grades summary in the chapter "technical instructions" and in the price list.

order-example:
righthand version and grade
R104.0205-15/AL41F

ULTRAMINI

Bohrungsbearbeitung
ab \varnothing 0.2 mm

grooving, boring and profiling
starting at \varnothing 0.2 mm

Typ Gewindedrehen

Whitworth-Gewinde,
Teilprofil, innen

D min. 4.8 - 7.0 mm

type threading,
Whitworth thread,
partial profile, internal

D min. 4.8 - 7.0 mm

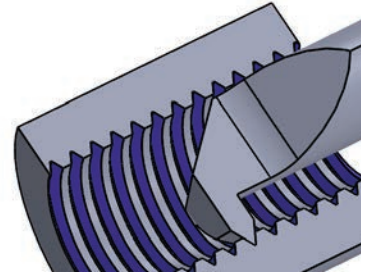
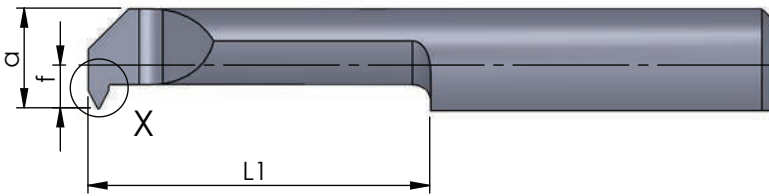
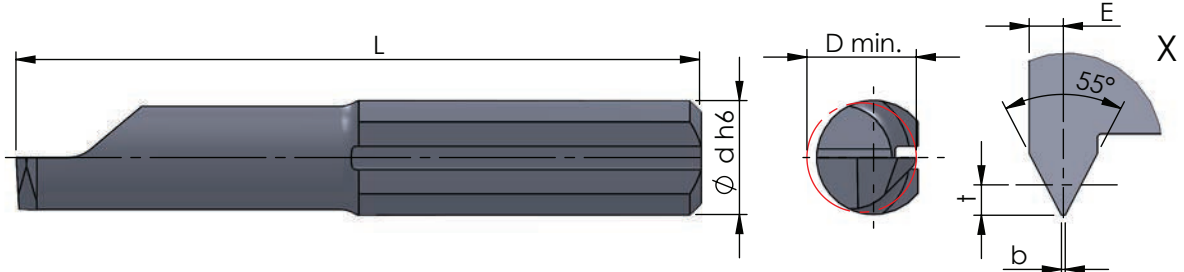

Rechts (R): wie gezeichnet
Links (L): spiegelbildlich

righthand (R): as shown
lefthand version (L): mirror image

Abmessungen in mm

dimensions in mm

Bestellnummer part number	Gang / Zoll threads / inch	t	E	b	f	a	L	L1	D min.	\varnothing d h6	Klemmhalter Typ				Klemmhalter Typ toolholder type
											K10F	CN45F	AL41F	PD2F	
R/L 005.5548-15	48 - 24	0.40	0.45	0.06	1.9	4.4	30	15	4.8	5.0	●				645... 650... ...5
R/L 006.5548-15	48 - 24	0.40	0.45	0.06	2.3	5.3	30	15	6.0	6.0	●				
R/L 006.5524-15	24 - 16	0.81	0.75	0.12	2.3	5.3	30	15	6.0	6.0	●				676... 660... ...6
R/L 007.5524-15	24 - 16	0.81	0.75	0.12	2.8	6.3	30	15	7.0	7.0	●				676... 670... 687... ...7

Weitere HM Sorten können Sie in der Sortenübersicht im Kapitel "Technische Hinweise" und der Preisliste finden.

Bestellbeispiel:
für rechte Ausführung und Sorte
R005.5548-15/CN45F

weitere Informationen:

- siehe Technische Hinweise

more informations:

- look at the technical instructions

More carbide grades you can find in the grades summary in the chapter "technical instructions" and in the price list.

order-example:
righthand version and grade
R005.5548-15/CN45F

ULTRAMINI

Bohrungsbearbeitung
ab $\varnothing 0.2 \text{ mm}$

grooving, boring and profiling
starting at $\varnothing 0.2 \text{ mm}$

Typ Gewindedrehen

Whitworth-Gewinde,
Vollprofil, innen

D min. 6.0 mm

type threading,
Whitworth thread,
full profile, internal

D min. 6.0 mm

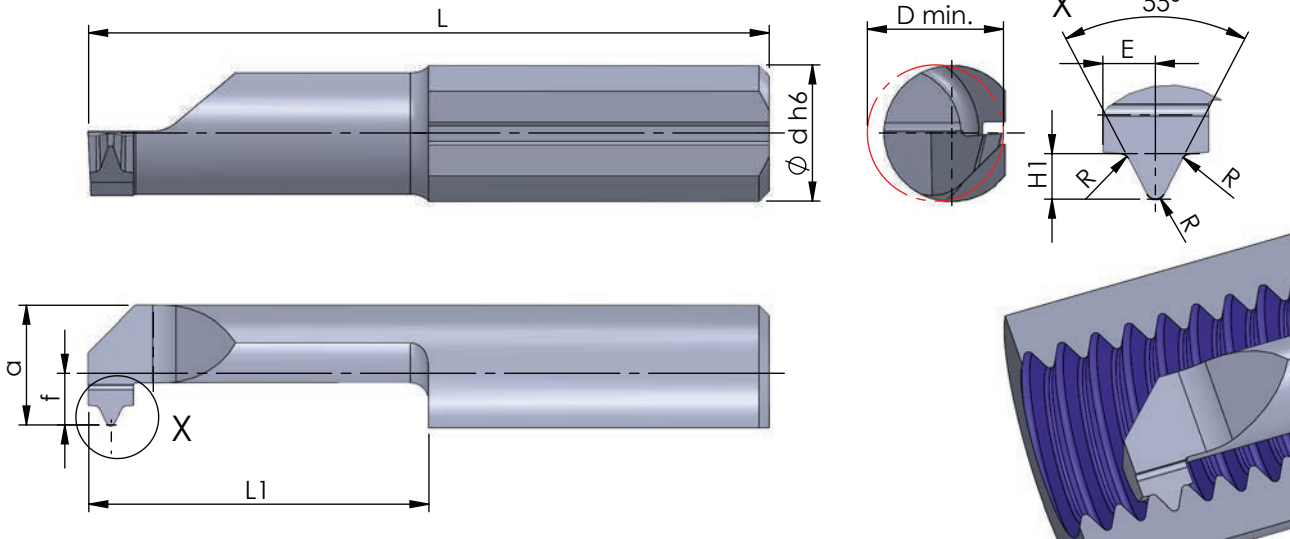

Rechts (R): wie gezeichnet
Links (L): spiegelbildlich

righthand (R): as shown
lefthand version (L): mirror image

Abmessungen in mm

dimensions in mm

Bestellnummer part number	Steigung P pitch P	Gang / Zoll threads / inch	H1	R	E	f	a	L	L1	D min.	$\varnothing d h6$	Klemmhalter Typ toolholder type				
												K10F	CN45F	AL41F	PD2F	
R/L 106.5519-15	1.336	19	0.86	0.18	1	2.3	5.3	30	15	6.0	6.0	●				
R/L 106.5522-15	1.154	22	0.74	0.16	1	2.3	5.3	30	15	6.0	6.0	●			660,...	676,...
R/L 106.5528-15	0.907	28	0.58	0.12	0.8	2.3	5.3	30	15	6.0	6.0	●		6

Weitere HM Sorten können Sie in der Sortenübersicht im Kapitel "Technische Hinweise" und der Preisliste finden.

Bestellbeispiel:
für rechte Ausführung und Sorte
R106.5519-15/AL41F

weitere Informationen:

- siehe Technische Hinweise

more informations:

- look at the technical instructions

More carbide grades you can find in the grades summary in the chapter "technical instructions" and in the price list.

order-example:
righthand version and grade
R106.5519-15/AL41F

ULTRAMINI

Bohrungsbearbeitung
ab $\varnothing 0.2 \text{ mm}$

grooving, boring and profiling
starting at $\varnothing 0.2 \text{ mm}$

Typ Gewindedrehen

NPT-Gewinde,
Teilprofil, innen

D min. 6.0 mm

type threading,
NPT thread,
partial profile, internal

D min. 6.0 mm

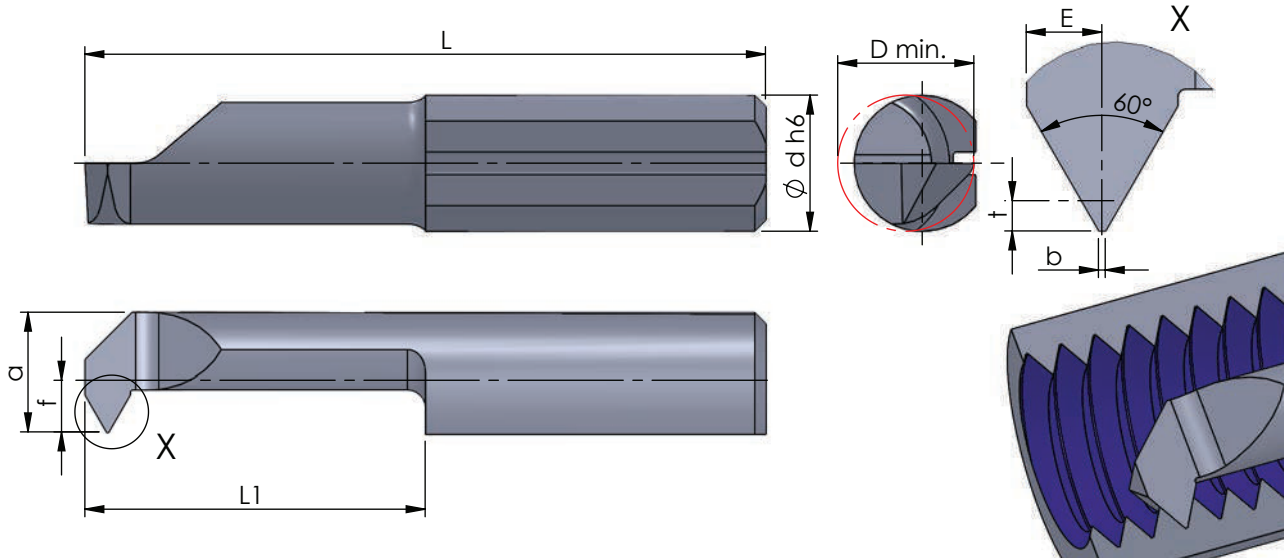

Rechts (R): wie gezeichnet
Links (L): spiegelbildlich

righthand (R): as shown
lefthand version (L): mirror image

Abmessungen in mm

dimensions in mm

Bestellnummer part number	Steigung P pitch P	Gang / Zoll threads / inch								D min.	Ø d h6	Klemmhalter Typ toolholder type				
			t	E	b	f	a	L	L1			K10F	CN45F	AL41F	PD2F	
R/L 006.NP18-15	1.411	18	1.35	1	0.09	2.3	5.3	30	15	6.0	6.0		●			
R/L 006.NP18-22	1.411	18	1.35	1	0.09	2.3	5.3	37	22	6.0	6.0		●			
R/L 006.NP27-15	0.940	27	1	0.8	0.06	2.3	5.3	30	15	6.0	6.0		●			660... 676... ...6
R/L 006.NP27-22	0.940	27	1	0.8	0.06	2.3	5.3	37	22	6.0	6.0		●			

Weitere HM Sorten können Sie in der Sortenübersicht im Kapitel "Technische Hinweise" und der Preisliste finden.

Bestellbeispiel:
für rechte Ausführung und Sorte
R006.NP18-15/AL41F

weitere Informationen:

- siehe Technische Hinweise

more informations:

- look at the technical instructions

More carbide grades you can find in the grades summary in the chapter "technical instructions" and in the price list.

order-example:
righthand version and grade
R006.NP18-15/AL41F

ULTRAMINI

Bohrungsbearbeitung
ab $\varnothing 0.2 \text{ mm}$

grooving, boring and profiling
starting at $\varnothing 0.2 \text{ mm}$

Typ Gewindedrehen

Trapezgewinde,
Teilprofil, innen

type threading,
trapezoidal thread,
partial profile, internal

D min. 7.0 mm
Steigung P = 2.0 - 3.0

D min. 7.0 mm
pitch P = 2.0 - 3.0

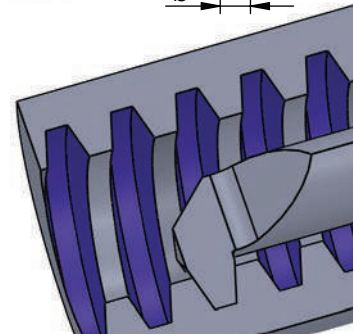
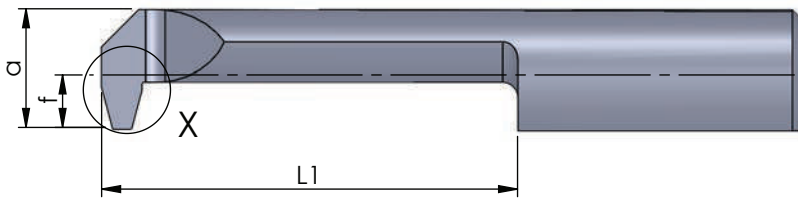
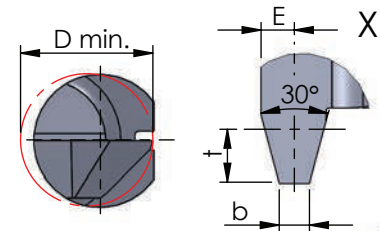
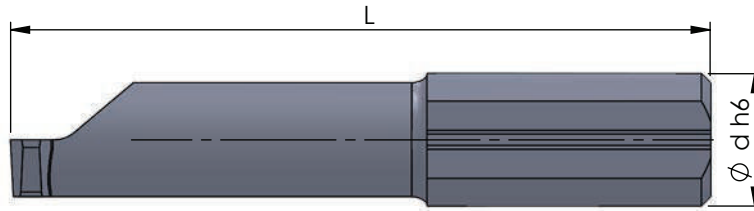

Rechts (R): wie gezeichnet
Links (L): spiegelbildlich

righthand (R): as shown
lefthand version (L): mirror image

Abmessungen in mm

dimensions in mm

Bestellnummer part number	Steigung P pitch P	t	E	b	f	a	L	L1	D min.	Ø d h6	Klemmhalter Typ toolholder type				
											K10F	CN45F	AL41F	PD2F	
R/L 007.1220-22	2	1.25	0.75	0.6	2.8	6.3	37	22	7.0	7.0		●			
R/L 007.1220-30	2	1.25	0.75	0.6	2.8	6.3	45	30	7.0	7.0		●			670, ... 676, ... 687,7
R/L 007.1730-22	3	1.75	1.10	1.0	2.8	6.3	37	22	7.0	7.0		●			
R/L 007.1730-30	3	1.75	1.10	1.0	2.8	6.3	45	30	7.0	7.0		●			

Weitere HM Sorten können Sie in der Sortenübersicht im Kapitel "Technische Hinweise" und der Preisliste finden.

Bestellbeispiel:
für rechte Ausführung und Sorte
R007.1220-22/AL41F

weitere Informationen:
• siehe Technische Hinweise

more informations:
• look at the technical instructions

More carbide grades you can find in the grades summary in the chapter "technical instructions" and in the price list.

order-example:
righthand version and grade
R007.1220-22/AL41F

ULTRAMINI

Bohrungsbearbeitung
ab \varnothing 0.2 mm

grooving, boring and profiling
starting at \varnothing 0.2 mm

Impressionen

impressions

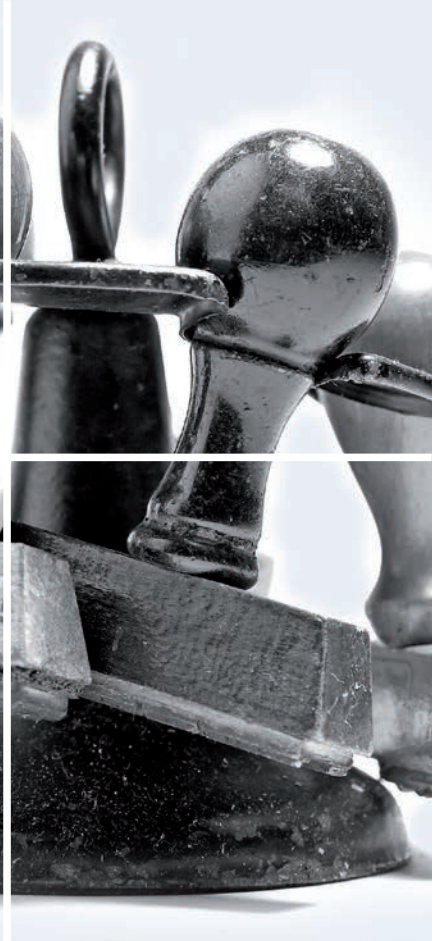

ULTRAMINI

Bohrungsbearbeitung
ab $\varnothing 0.2$ mm

grooving, boring and profiling
starting at $\varnothing 0.2$ mm

Typ 510M

Axialstechen
mit Eckenradius

face grooving
with corner radius

D min. 5.0 mm
Stechtiefe t max. 4.0 mm
Nutbreite bis 2.0 mm

D min. 5.0 mm
depth of groove t max. 4.0 mm
width of groove up to 2.0 mm

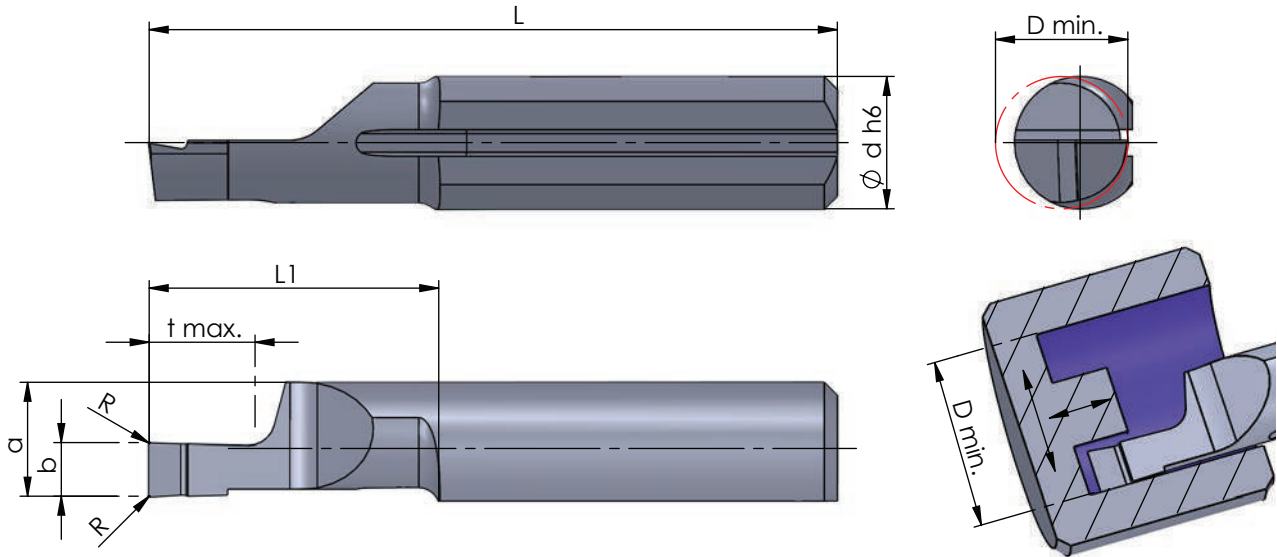

Rechts (R): wie gezeichnet
Links (L): spiegelbildlich

righthand (R): as shown
lefthand version (L): mirror image

Abmessungen in mm

dimensions in mm

Bestellnummer part number	b +0.05	a	L	L1	t max.	D min.	$\varnothing d h6$	R	Klemmhalter Typ toolholder type				
									K10F	CN45F	AL41F	P07C	
R/L 510M1008-10	1.0	4.3	26	11	2.0	5.0	5.0	0.05					
R/L 510M1508-10	1.5	4.3	26	11	3.0	5.0	5.0	0.05					
R/L 510M2008-10	2.0	4.3	26	11	4.0	5.0	5.0	0.05					
R/L 510M1008-20	1.0	4.3	35	20	2.0	5.0	5.0	0.05					645... 650... ...5
R/L 510M1508-20	1.5	4.3	35	20	3.0	5.0	5.0	0.05					
R/L 510M2008-20	2.0	4.3	35	20	4.0	5.0	5.0	0.05					

Weitere HM Sorten können Sie in der Sortenübersicht im Kapitel "Technische Hinweise" und der Preisliste finden.

Bestellbeispiel:
für rechte Ausführung und Sorte
R510M1008-10/AL41F

More carbide grades you can find in the grades summary in the chapter "technical instructions" and in the price list.

order-example:
righthand version and grade
R510M1008-10/AL41F

ULTRAMINI

Bohrungsbearbeitung
ab $\varnothing 0.2 \text{ mm}$

grooving, boring and profiling
starting at $\varnothing 0.2 \text{ mm}$

Typ 610

Axialstechen

face grooving

D min. 6.0 mm
Stechtiefe t max. 3.5 mm
Nutbreite bis 3.0 mm

D min. 6.0 mm
depth of groove tmax. 3.5 mm
width of groove up to 3.0 mm

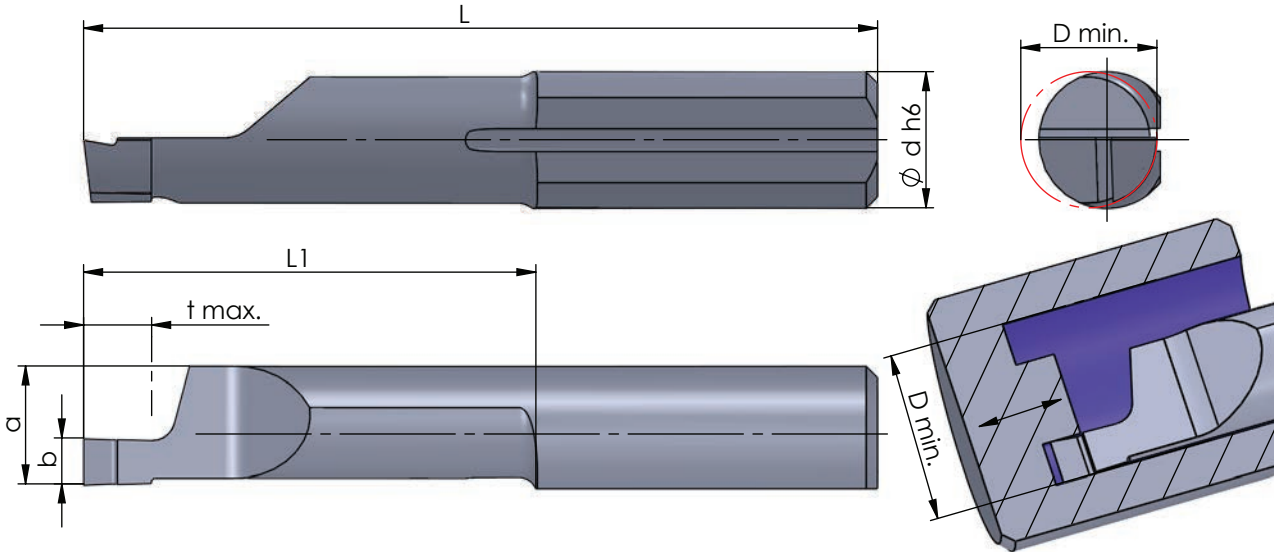

Rechts (R): wie gezeichnet
Links (L): spiegelbildlich

righthand (R): as shown
lefthand version (L): mirror image

Abmessungen in mm

dimensions in mm

Bestellnummer part number	b +0.05	a	L	L1	t max.	D min.	$\varnothing d h6$	K10F CN45F AL41F P07C	Klemmhalter Typ	toolholder type
R/L 610.1008-10	1.0	5.2	26	11	1.5	6.0	6.0	● ● ●	660... 676... ...6	
R/L 610.1508-10	1.5	5.2	26	11	2.5	6.0	6.0	● ● ●		
R/L 610.2008-10	2.0	5.2	26	11	3.0	6.0	6.0	● ● ●		
R/L 610.2508-10	2.5	5.2	26	11	3.5	6.0	6.0	● ● ●		
R/L 610.3008-10	3.0	5.2	26	11	3.5	6.0	6.0	● ● ●		
R/L 610.1008-20	1.0	5.2	35	20	1.5	6.0	6.0	● ● ●		
R/L 610.1508-20	1.5	5.2	35	20	2.5	6.0	6.0	● ● ●		
R/L 610.2008-20	2.0	5.2	35	20	3.0	6.0	6.0	● ● ●		
R/L 610.2508-20	2.5	5.2	35	20	3.5	6.0	6.0	● ● ●		
R/L 610.3008-20	3.0	5.2	35	20	3.5	6.0	6.0	● ● ●		
R/L 610.1008-30	1.0	5.2	45	30	1.5	6.0	6.0	● ● ●		
R/L 610.1508-30	1.5	5.2	45	30	2.5	6.0	6.0	● ● ●		
R/L 610.2008-30	2.0	5.2	45	30	3.0	6.0	6.0	● ● ●		
R/L 610.2508-30	2.5	5.2	45	30	3.5	6.0	6.0	● ● ●		
R/L 610.3008-30	3.0	5.2	45	30	3.5	6.0	6.0	● ● ●		

Weitere HM Sorten können Sie in der Sortenübersicht im Kapitel "Technische Hinweise" und der Preisliste finden.

Bestellbeispiel:
für rechte Ausführung und Sorte
R610.1008-10/AL41F

More carbide grades you can find in the grades summary in the chapter "technical instructions" and in the price list.

order-example:
righthand version and grade
R610.1008-10/AL41F

ULTRAMINI

Bohrungsbearbeitung
ab $\varnothing 0.2 \text{ mm}$

grooving, boring and profiling
starting at $\varnothing 0.2 \text{ mm}$

Typ 610M

Axialstechen
mit Eckenradius

face grooving
with corner radius

D min. 6.0 mm
Stechtiefe t max. 6.0 mm
Nutbreite bis 3.0 mm

D min. 6.0 mm
depth of groove t max. 6.0 mm
width of groove up to 3.0 mm

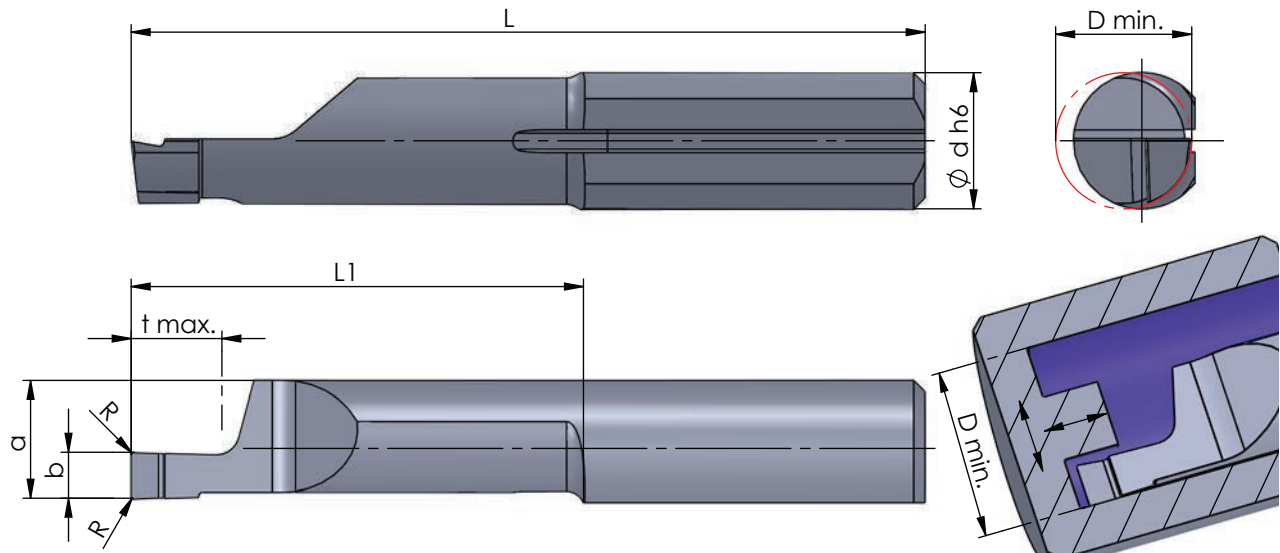

Rechts (R): wie gezeichnet
Links (L): spiegelbildlich

righthand (R): as shown
lefthand version (L): mirror image

Abmessungen in mm

dimensions in mm

Bestellnummer part number	b +0.05	a	L	L1	t max.	D min.	Ø d h6	R	Klemmhalter Typ toolholder type				
									K10F	CN45F	AL41F	P07C	
R/L 610M1008-10	1.0	5.2	26	11	2.0	6.0	6.0	0.1			●		660... 676... ...6
R/L 610M1508-10	1.5	5.2	26	11	3.0	6.0	6.0	0.1			●		
R/L 610M2008-10	2.0	5.2	26	11	4.0	6.0	6.0	0.1			●		
R/L 610M2508-10	2.5	5.2	26	11	5.0	6.0	6.0	0.1			●		
R/L 610M3008-10	3.0	5.2	26	11	6.0	6.0	6.0	0.1			●		
R/L 610M1008-20	1.0	5.2	35	20	2.0	6.0	6.0	0.1			●		
R/L 610M1508-20	1.5	5.2	35	20	3.0	6.0	6.0	0.1			●		
R/L 610M2008-20	2.0	5.2	35	20	4.0	6.0	6.0	0.1			●		
R/L 610M2508-20	2.5	5.2	35	20	5.0	6.0	6.0	0.1			●		
R/L 610M3008-20	3.0	5.2	35	20	6.0	6.0	6.0	0.1			●		
R/L 610M1008-30	1.0	5.2	45	30	2.0	6.0	6.0	0.1			●		
R/L 610M1508-30	1.5	5.2	45	30	3.0	6.0	6.0	0.1			●		
R/L 610M2008-30	2.0	5.2	45	30	4.0	6.0	6.0	0.1			●		
R/L 610M2508-30	2.5	5.2	45	30	5.0	6.0	6.0	0.1			●		
R/L 610M3008-30	3.0	5.2	45	30	6.0	6.0	6.0	0.1			●		

Weitere HM Sorten können Sie in der Sortenübersicht im Kapitel "Technische Hinweise" und der Preisliste finden.

Bestellbeispiel:
für rechte Ausführung und Sorte
R610M1008-10/AL41F

More carbide grades you can find in the grades summary in the chapter "technical instructions" and in the price list.

order-example:
righthand version and grade
R610M1008-10/AL41F

ULTRAMINI

Bohrungsbearbeitung
ab $\varnothing 0.2$ mm

grooving, boring and profiling
starting at $\varnothing 0.2$ mm

Typ 610

Axialstechen
mit Vollradius

face grooving
with full radius

D min. 6.0 mm
Stechtiefe t max. 6.0 mm
Nutbreite bis 3.0 mm

D min. 6.0 mm
depth of groove t max. 6.0 mm
width of groove up to 3.0 mm

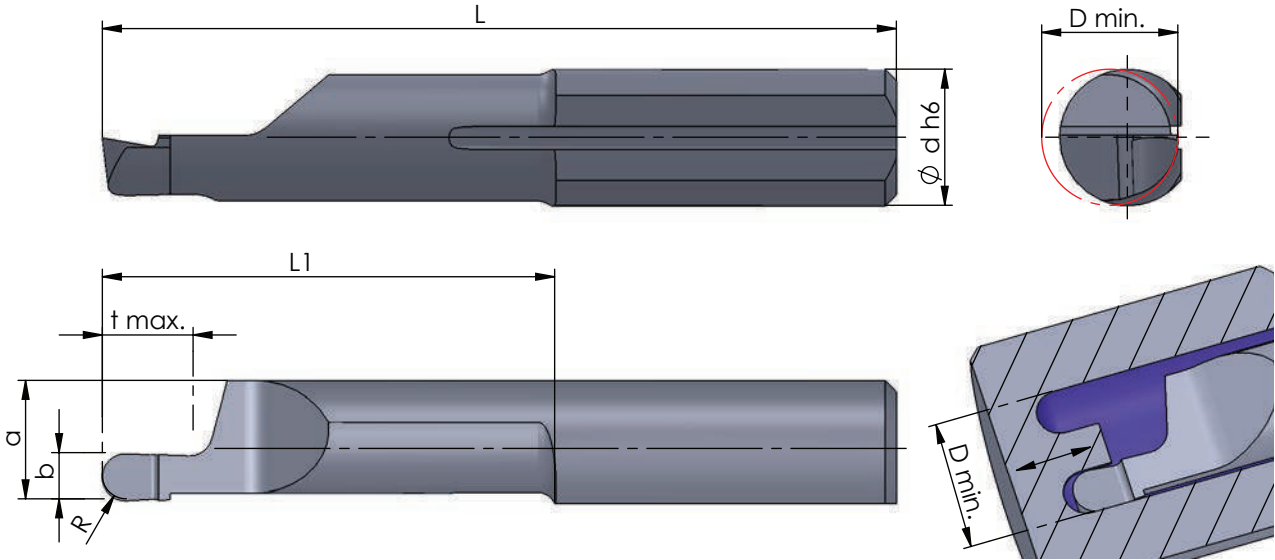

Rechts (R): wie gezeichnet
Links (L): spiegelbildlich

righthand (R): as shown
lefthand version (L): mirror image

Abmessungen in mm

dimensions in mm

Bestellnummer part number	b +0.05	R	a	L	L1	t max.	D min.	Ø d h6	K10F	CN45F	AL41F	P07C	Klemmhalter Typ	toolholder type
													660... 676... ...6	
R/L 610.1005-10	1.0	0.50	5.2	26	11	2.0	6.0	6.0	●	●				
R/L 610.1608-10	1.6	0.80	5.2	26	11	3.0	6.0	6.0		●				
R/L 610.2010-10	2.0	1.00	5.2	26	11	4.0	6.0	6.0			●			
R/L 610.2512-10	2.5	1.25	5.2	26	11	5.0	6.0	6.0	●		●			
R/L 610.3015-10	3.0	1.50	5.2	26	11	6.0	6.0	6.0	●		●			
R/L 610.1005-20	1.0	0.50	5.2	35	20	2.0	6.0	6.0	●	●				
R/L 610.1608-20	1.6	0.80	5.2	35	20	3.0	6.0	6.0			●			
R/L 610.2010-20	2.0	1.00	5.2	35	20	4.0	6.0	6.0	●		●			
R/L 610.2512-20	2.5	1.25	5.2	35	20	5.0	6.0	6.0			●			
R/L 610.3015-20	3.0	1.50	5.2	35	20	6.0	6.0	6.0	●		●			

Weitere HM Sorten können Sie in der Sortenübersicht im Kapitel "Technische Hinweise" und der Preisliste finden.

Bestellbeispiel:
für rechte Ausführung und Sorte
R610.1005-10/AL41F

More carbide grades you can find in the grades summary in the chapter "technical instructions" and in the price list.

order-example:
righthand version and grade
R610.1005-10/AL41F

ULTRAMINI

Bohrungsbearbeitung
ab \varnothing 0.2 mm

grooving, boring and profiling
starting at \varnothing 0.2 mm

Typ 620

Axialstechen
am Zapfen vorbei

face grooving
in pivots

D min. 6.0 mm
Stechtiefe t max. 6.0 mm
Nutbreite bis 3.0 mm

D min. 6.0 mm
depth of groove t max. 6.0 mm
width of groove up to 3.0 mm

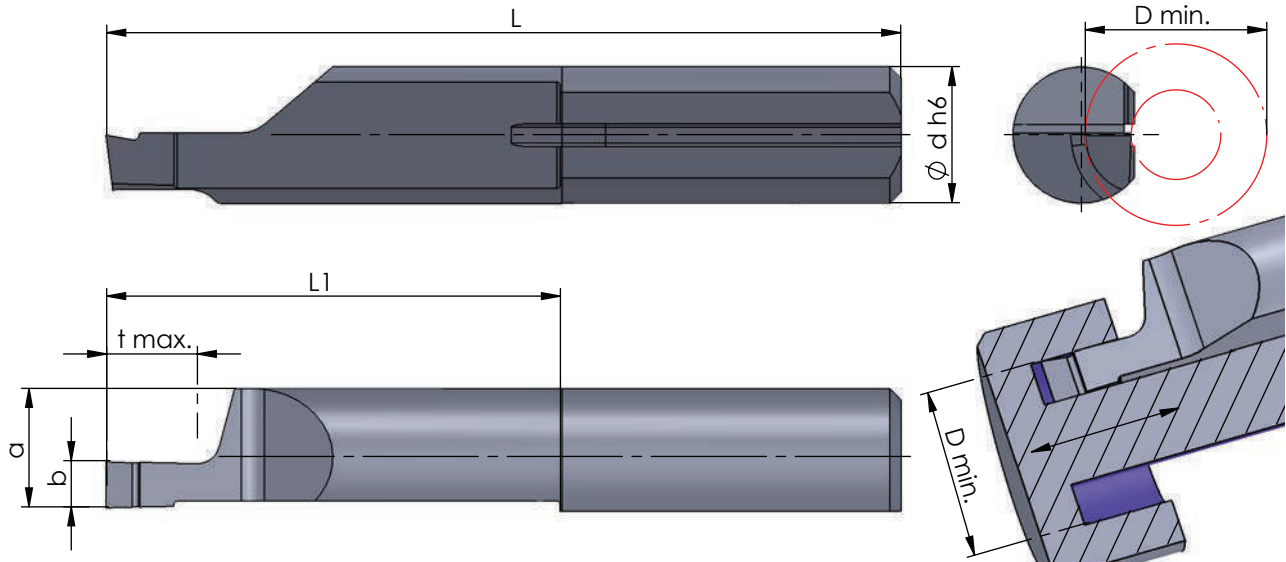

Rechts (R): wie gezeichnet
Links (L): spiegelbildlich

righthand (R): as shown
lefthand version (L): mirror image

Abmessungen in mm

dimensions in mm

Bestellnummer part number	b +0.05	a	L	L1	t max.	D min.	Ø d h6					Klemmhalter Typ toolholder type
								K10F	CN45F	AL41F	PD2F	
R/L 620.1006-20	1.0	5.2	35	20	2.0	6.0	6.0	●	●	●		660... 676... ...6
R/L 620.1506-20	1.5	5.2	35	20	3.0	6.0	6.0	●	●	●		
R/L 620.2006-20	2.0	5.2	35	20	4.0	6.0	6.0	●	●	●		
R/L 620.2506-20	2.5	5.2	35	20	5.0	6.0	6.0		●	●		
R/L 620.3006-20	3.0	5.2	35	20	6.0	6.0	6.0		●	●		

Weitere HM Sorten können Sie in der Sortenübersicht im Kapitel "Technische Hinweise" und der Preisliste finden.

Bestellbeispiel:
für rechte Ausführung und Sorte
R620.1006-20/AL41F

More carbide grades you can find in the grades summary in the chapter "technical instructions" and in the price list.

order-example:
righthand version and grade
R620.1006-20/AL41F

ULTRAMINI

Bohrungsbearbeitung
ab $\varnothing 0.2$ mm

grooving, boring and profiling
starting at $\varnothing 0.2$ mm

Typ 620M

Axialstechen
am Zapfen vorbei,
mit Eckenradius

face grooving
in pivots,
with corner radius

D min. 6.0 mm
Stechtiefe t max. 6.0 mm
Nutbreite bis 3.0 mm

D min. 6.0 mm
depth of groove t max. 6.0 mm
width of groove up to 3.0 mm

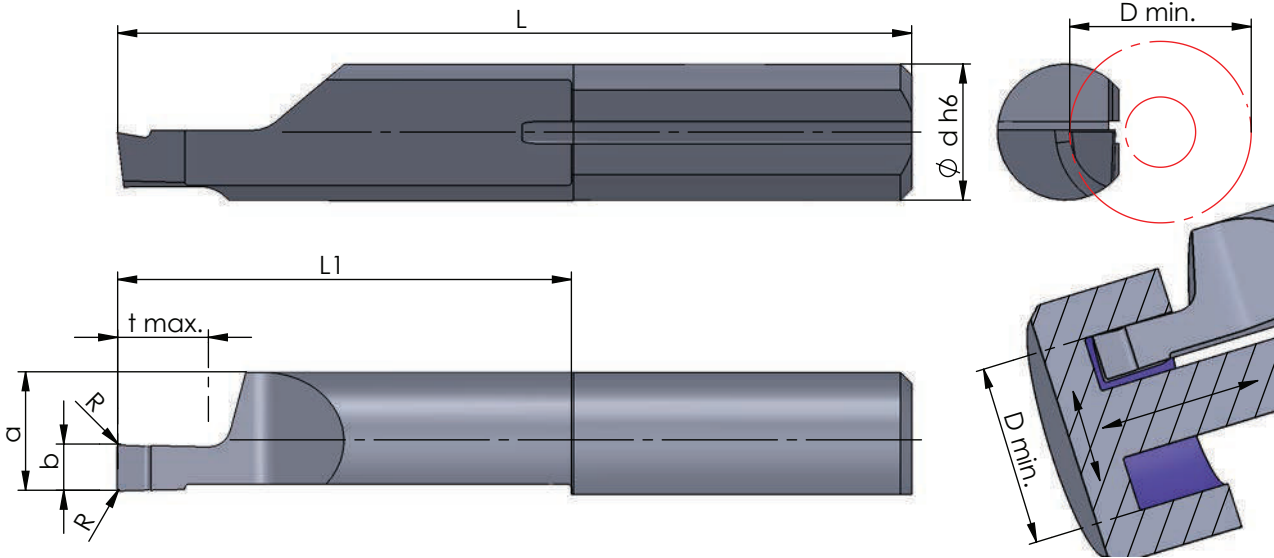

Rechts (R): wie gezeichnet
Links (L): spiegelbildlich

righthand (R): as shown
lefthand version (L): mirror image

Abmessungen in mm

dimensions in mm

Bestellnummer part number	b +0.05	a	L	L1	t max.	D min.	$\varnothing d h6$	R	K10F CN45F AL41F PD2F	Klemmhalter Typ	toolholder type
R/L 620M1006-20	1.0	5.2	35	20	2.0	6.0	6.0	0.1			
R/L 620M1506-20	1.5	5.2	35	20	3.0	6.0	6.0	0.1			
R/L 620M2006-20	2.0	5.2	35	20	4.0	6.0	6.0	0.1			660... 676... ...6
R/L 620M2506-20	2.5	5.2	35	20	5.0	6.0	6.0	0.1			
R/L 620M3006-20	3.0	5.2	35	20	6.0	6.0	6.0	0.1			

Weitere HM Sorten können Sie in der Sortenübersicht im Kapitel "Technische Hinweise" und der Preisliste finden.

Bestellbeispiel:
für rechte Ausführung und Sorte
R620M1006-20/AL41F

More carbide grades you can find in the grades summary in the chapter "technical instructions" and in the price list.

order-example:
righthand version and grade
R620M1006-20/AL41F

ULTRAMINI

Bohrungsbearbeitung
ab $\varnothing 0.2 \text{ mm}$

grooving, boring and profiling
starting at $\varnothing 0.2 \text{ mm}$

Typ 010

Axialstechen

face grooving

D min. 6.0 mm
Stechtiefe t max. 3.5 mm
Nutbreite bis 3.0 mm

D min. 6.0 mm
depth of groove t max. 3.5 mm
width of groove up to 3.0 mm

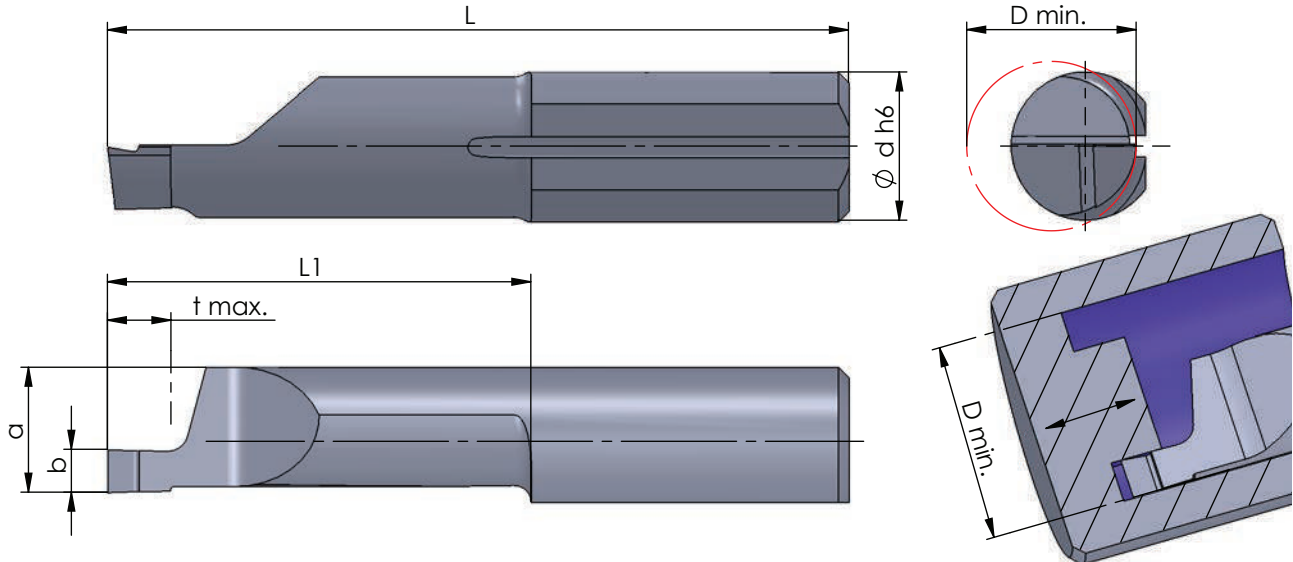

Rechts (R): wie gezeichnet
Links (L): spiegelbildlich

righthand (R): as shown
lefthand version (L): mirror image

Abmessungen in mm

dimensions in mm

Bestellnummer part number	b +0.05	a	L	L1	t max.	D min.	$\varnothing d h6$					Klemmhalter Typ toolholder type
								K10F	CN45F	AL41F	P07C	
R/L 010.1006-10	1.0	5.2	26	11	1.5	6.0	6.0	●	●			660... ...6
R/L 010.1506-10	1.5	5.2	26	11	2.0	6.0	6.0	●	●			
R/L 010.1008-10	1.0	5.9	26	11	1.5	8.0	7.0	●	●			
R/L 010.1508-10	1.5	5.9	26	11	2.5	8.0	7.0	●	●			
R/L 010.2008-10	2.0	5.9	26	11	3.0	8.0	7.0	●	●			
R/L 010.2508-10	2.5	5.9	26	11	3.5	8.0	7.0	●	●			
R/L 010.3008-10	3.0	5.9	26	11	3.5	8.0	7.0	●	●			
R/L 010.1008-20	1.0	5.9	35	20	1.5	8.0	7.0	●	●		676...	670... 687... ...7
R/L 010.1508-20	1.5	5.9	35	20	2.5	8.0	7.0	●	●			
R/L 010.2008-20	2.0	5.9	35	20	3.0	8.0	7.0	●	●			
R/L 010.2508-20	2.5	5.9	35	20	3.5	8.0	7.0	●	●			
R/L 010.3008-20	3.0	5.9	35	20	3.5	8.0	7.0	●	●			
↳ ...												

Weitere HM Sorten können Sie in der Sortenübersicht im Kapitel "Technische Hinweise" und der Preisliste finden.

Bestellbeispiel:
für rechte Ausführung und Sorte
R010.1006-10/AL41F

More carbide grades you can find in the grades summary in the chapter "technical instructions" and in the price list.

order-example:
righthand version and grade
R010.1006-10/AL41F

ULTRAMINI

Bohrungsbearbeitung
ab \varnothing 0.2 mm

grooving, boring and profiling
starting at \varnothing 0.2 mm

Typ 010

Axialstechen

face grooving

D min. 6.0 mm
Stechtiefe t max. 3.5 mm
Nutbreite bis 3.0 mm

D min. 6.0 mm
depth of groove t max. 3.5 mm
width of groove up to 3.0 mm

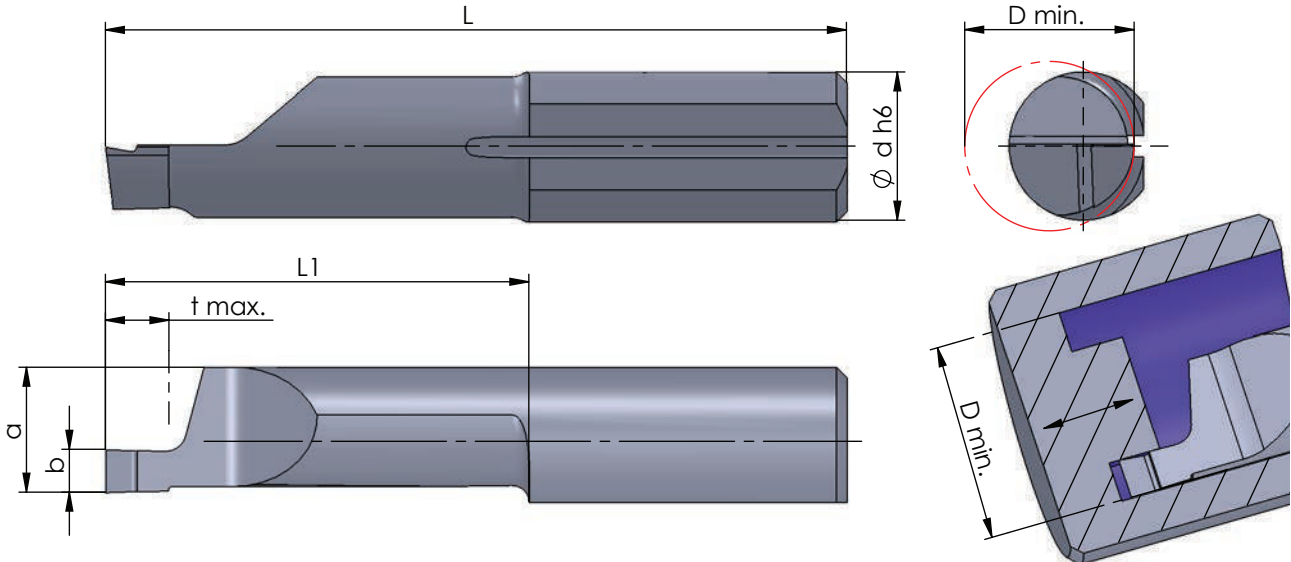

Rechts (R): wie gezeichnet
Links (L): spiegelbildlich

righthand (R): as shown
lefthand version (L): mirror image

Abmessungen in mm

dimensions in mm

Bestellnummer part number	b +0.05	a	L	L1	t max.	D min.	Ø d h6	Klemmhalter Typ				toolholder type
								K10F	CN45F	AL41F	P07C	
...												
R/L 010.1008-30	1.0	5.9	45	30	1.5	8.0	7.0	●	●			
R/L 010.1508-30	1.5	5.9	45	30	2.5	8.0	7.0	●	●			
R/L 010.2008-30	2.0	5.9	45	30	3.0	8.0	7.0	●	●			670... 676... 687... ...7
R/L 010.2508-30	2.5	5.9	45	30	3.5	8.0	7.0	●	●			
R/L 010.3008-30	3.0	5.9	45	30	3.5	8.0	7.0	●	●			

Weitere HM Sorten können Sie in der Sortenübersicht im Kapitel "Technische Hinweise" und der Preisliste finden.

More carbide grades you can find in the grades summary in the chapter "technical instructions" and in the price list.

Bestellbeispiel:
für rechte Ausführung und Sorte
R010.1008-30/AL41F

order-example:
righthand version and grade
R010.1008-30/AL41F

ULTRAMINI

Bohrungsbearbeitung
ab $\varnothing 0.2$ mm

grooving, boring and profiling
starting at $\varnothing 0.2$ mm

Typ 010M

Axialstechen
mit Eckenradius

face grooving
with corner radius

D min. 8.0 mm
Stechtiefe t max. 6.0 mm
Nutbreite bis 3.0 mm

D min. 8.0 mm
depth of groove t max. 6.0 mm
width of groove up to 3.0 mm

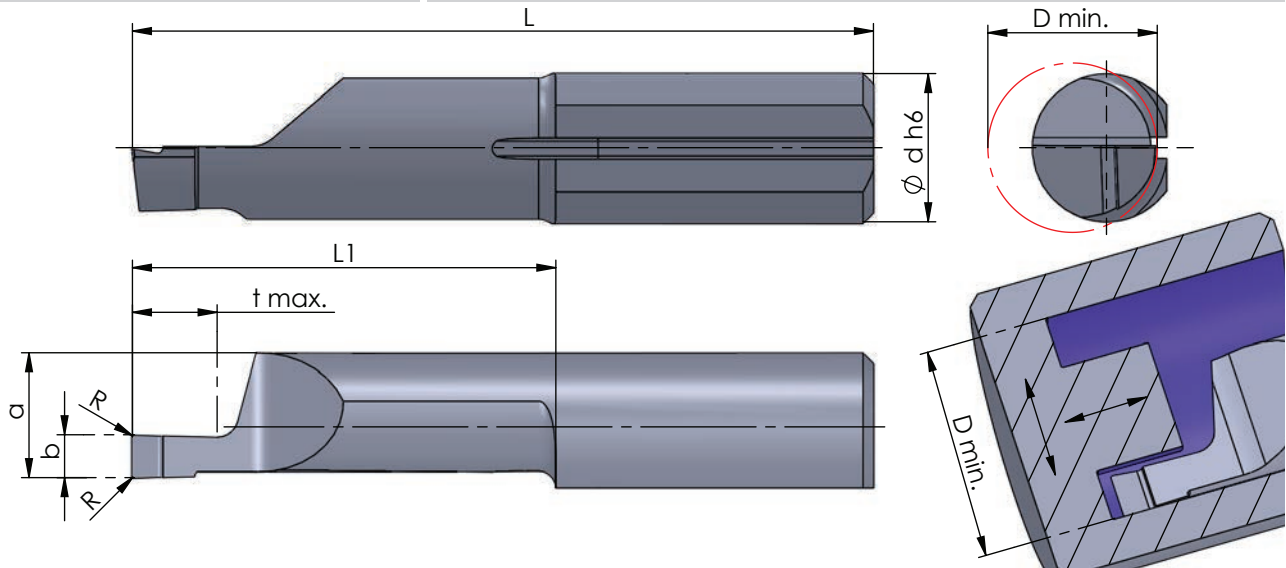

Rechts (R): wie gezeichnet
Links (L): spiegelbildlich

righthand (R): as shown
lefthand version (L): mirror image

Abmessungen in mm

dimensions in mm

Bestellnummer part number	b +0.05	b (inch)	a	L	L1	t max.	D min.	Ø d h6	R	Klemmhalter Typ toolholder type				
										K10F	CN45F	AL41F	P07C	
R/L 010M1008-10	1.0		5.9	26	11	2.0	8.0	7.0	0.1					670... 676... 687... ...7
R/L 010M1508-10	1.5		5.9	26	11	3.0	8.0	7.0	0.1					
R/L 010M1578-10	1.57	0.062"	5.9	26	11	3.0	8.0	7.0	0.1					
R/L 010M2008-10	2.0		5.9	26	11	4.0	8.0	7.0	0.1					
R/L 010M2508-10	2.5		5.9	26	11	5.0	8.0	7.0	0.1					
R/L 010M3008-10	3.0		5.9	26	11	6.0	8.0	7.0	0.1					
R/L 010M1008-20	1.0		5.9	35	20	2.0	8.0	7.0	0.1					
R/L 010M1508-20	1.5		5.9	35	20	3.0	8.0	7.0	0.1					
R/L 010M2008-20	2.0		5.9	35	20	4.0	8.0	7.0	0.1					
R/L 010M2308-20	2.38	0.094"	5.9	35	20	5.0	8.0	7.0	0.1					
R/L 010M2508-20	2.5		5.9	35	20	5.0	8.0	7.0	0.1					
R/L 010M3008-20	3.0		5.9	35	20	6.0	8.0	7.0	0.1					
↳ ...														

Weitere HM Sorten können Sie in der Sortenübersicht im Kapitel "Technische Hinweise" und der Preisliste finden.

Bestellbeispiel:
für rechte Ausführung und Sorte
R010M1008-10/AL41F

More carbide grades you can find in the grades summary in the chapter "technical instructions" and in the price list.

order-example:
righthand version and grade
R010M1008-10/AL41F

ULTRAMINI

Bohrungsbearbeitung
ab $\varnothing 0.2$ mm

grooving, boring and profiling
starting at $\varnothing 0.2$ mm

Typ 010M

Axialstechen
mit Eckenradius

face grooving
with corner radius

D min. 8.0 mm
Stechtiefe t max. 6.0 mm
Nutbreite bis 3.0 mm

D min. 8.0 mm
depth of groove t max. 6.0 mm
width of groove up to 3.0 mm

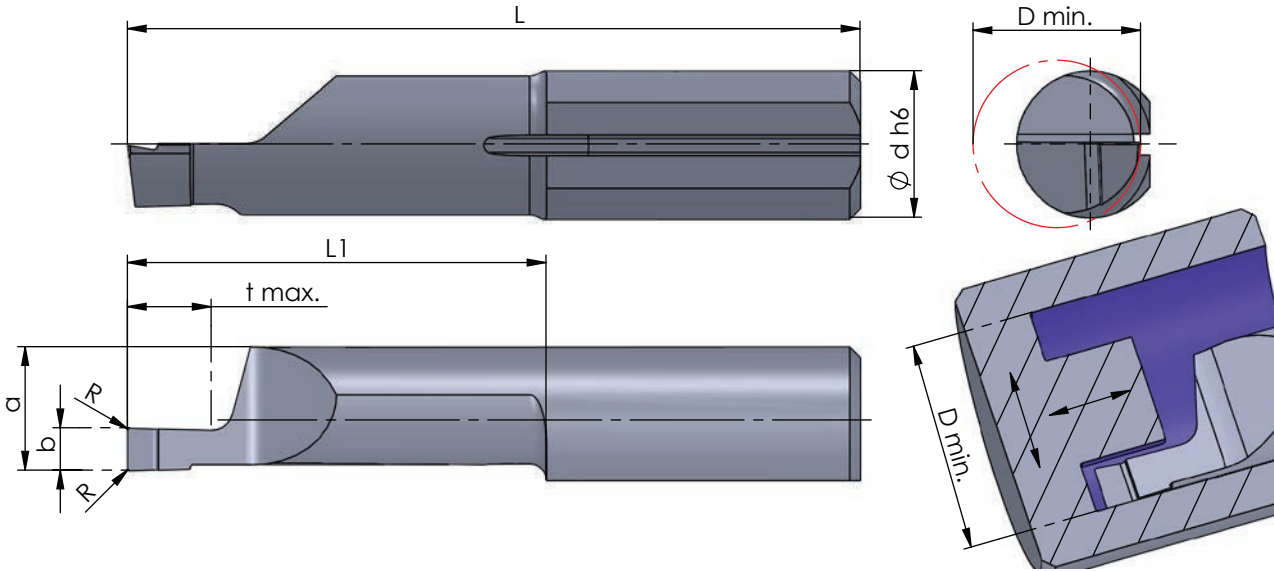

Rechts (R): wie gezeichnet
Links (L): spiegelbildlich

righthand (R): as shown
lefthand version (L): mirror image

Abmessungen in mm

dimensions in mm

Bestellnummer part number	b +0.05	b (inch)	a	L	L1	t max.	D min.	\varnothing d h6	R	Klemmhalter Typ toolholder type				
										K10F	CN45F	AL41F	P07C	
...														
R/L 010M1008-30	1.0		5.9	45	30	2.0	8.0	7.0	0.1		●			
R/L 010M1508-30	1.5		5.9	45	30	3.0	8.0	7.0	0.1		●			
R/L 010M2008-30	2.0		5.9	45	30	4.0	8.0	7.0	0.1		●			670, ... 676, ... 687,,7
R/L 010M2508-30	2.5		5.9	45	30	5.0	8.0	7.0	0.1		●			
R/L 010M3008-30	3.0		5.9	45	30	6.0	8.0	7.0	0.1		●			

Weitere HM Sorten können Sie in der Sortenübersicht im Kapitel "Technische Hinweise" und der Preisliste finden.

Bestellbeispiel:
für rechte Ausführung und Sorte
R010M1008-30/AL41F

More carbide grades you can find in the grades summary in the chapter "technical instructions" and in the price list.

order-example:
righthand version and grade
R010M1008-30/AL41F

ULTRAMINI

Bohrungsbearbeitung
ab $\varnothing 0.2 \text{ mm}$

grooving, boring and profiling
starting at $\varnothing 0.2 \text{ mm}$

Typ 010

Axialstechen
mit Vollradius

face grooving
with full radius

D min. 8.0 mm
Stechtiefe t max. 6.0 mm
Nutbreite bis 3.0 mm

D min. 8.0 mm
depth of groove t max. 6.0 mm
width of groove up to 3.0 mm

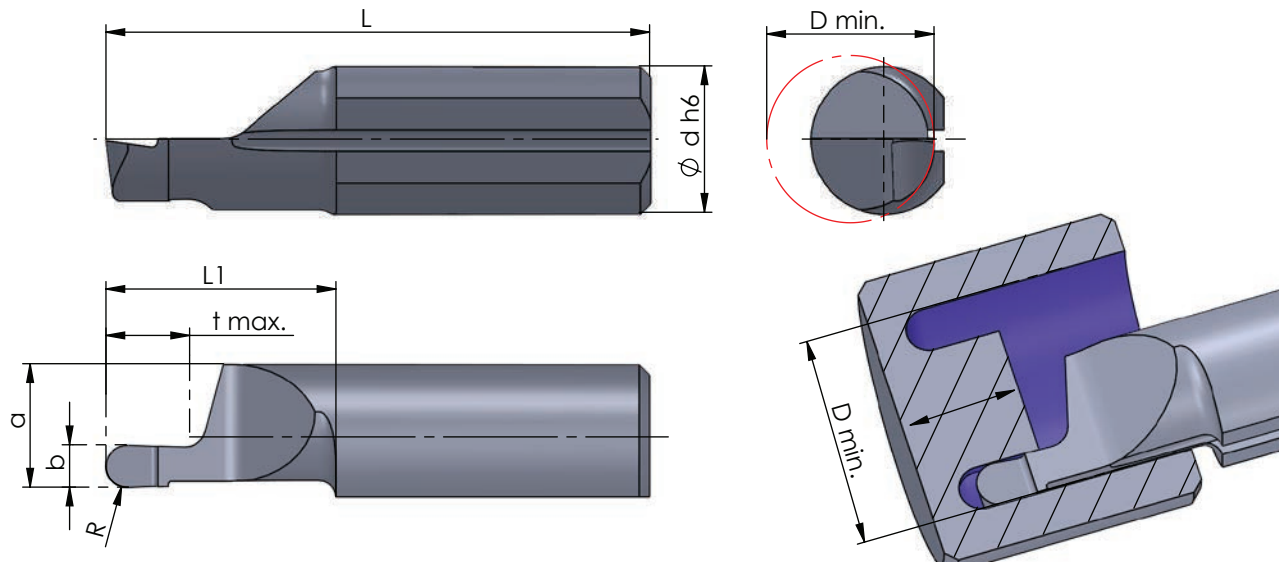

Rechts (R): wie gezeichnet
Links (L): spiegelbildlich

righthand (R): as shown
lefthand version (L): mirror image

Abmessungen in mm

dimensions in mm

Bestellnummer part number	b +0.05	b (inch)	R	a	L	L1	t max.	D min.	$\varnothing d h6$	Klemmhalter Typ				Klemmhalter Typ toolholder type
										K10F	CN45F	AL41F	PD2F	
R/L 010.1005-10	1.0		0.5	5.9	26	11	2.0	8.0	7.0		●	●		670... 676... 687... ...7
R/L 010.1507-10	1.57	0.062"	0.78	5.9	26	11	3.0	8.0	7.0		●			
R/L 010.1608-10	1.6		0.8	5.9	26	11	3.0	8.0	7.0		●	●		
R/L 010.1910-10	1.98	0.078"	0.99	5.9	26	11	4.0	8.0	7.0		●			
R/L 010.2010-10	2.0		1.0	5.9	26	11	4.0	8.0	7.0		●	●		
R/L 010.2512-10	2.5		1.25	5.9	26	11	5.0	8.0	7.0		●			
R/L 010.3015-10	3.0		1.5	5.9	26	11	6.0	8.0	7.0		●	●		
R/L 010.1005-20	1.0		0.5	5.9	35	20	2.0	8.0	7.0		●	●		
R/L 010.1608-20	1.6		0.8	5.9	35	20	3.0	8.0	7.0		●			
R/L 010.2010-20	2.0		1.0	5.9	35	20	4.0	8.0	7.0		●	●		
R/L 010.2512-20	2.5		1.25	5.9	35	20	5.0	8.0	7.0		●	●		
R/L 010.3015-20	3.0		1.5	5.9	35	20	6.0	8.0	7.0		●	●		

Weitere HM Sorten können Sie in der Sortenübersicht im Kapitel "Technische Hinweise" und der Preisliste finden.

Bestellbeispiel:
für rechte Ausführung und Sorte
R010.1005-10/AL41F

More carbide grades you can find in the grades summary in the chapter "technical instructions" and in the price list.

order-example:
righthand version and grade
R010.1005-10/AL41F

ULTRAMINI

Bohrungsbearbeitung
ab \varnothing 0.2 mm

grooving, boring and profiling
starting at \varnothing 0.2 mm

Typ 015

Axialstechen

face grooving

D min. 8.0 mm
Stechtiefe t max. 30 mm
Nutbreite bis 3.0 mm

D min. 8.0 mm
depth of groove t max. 30 mm
width of groove up to 3.0 mm

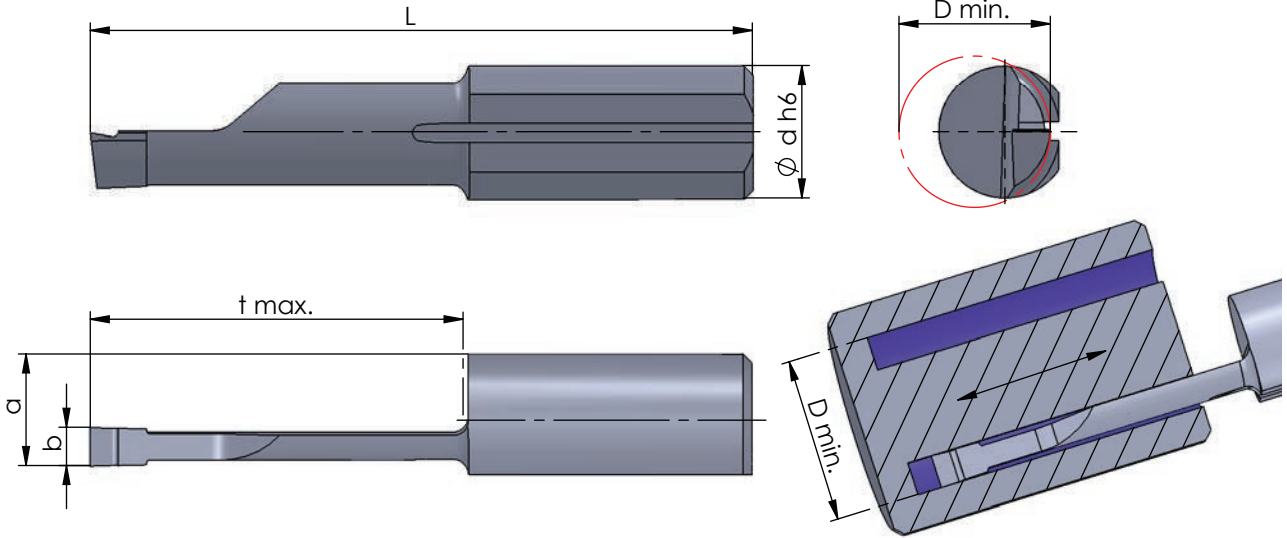

Rechts (R): wie gezeichnet
Links (L): spiegelbildlich

righthand (R): as shown
lefthand version (L): mirror image

Abmessungen in mm

dimensions in mm

Bestellnummer part number	b +0.05	a	L	t max.	D min.	Ø d h6	Klemmhalter Typ				toolholder type
							K10F	CN45F	AL41F	PD2F	
R/L 015.1515-10	1.5	5.9	26	10	8.0	7.0	●	●	●		
R/L 015.2015-15	2.0	5.9	30	15	8.0	7.0		●	●		
R/L 015.2015-20	2.0	5.9	35	20	8.0	7.0	●	●	●		
R/L 015.2515-20	2.5	5.9	35	20	8.0	7.0		●	●		670... 676... 687... ...7
R/L 015.3015-20	3.0	5.9	35	20	8.0	7.0	●	●	●		
R/L 015.3015-30	3.0	5.9	45	30	8.0	7.0		●	●		

Weitere HM Sorten können Sie in der Sortenübersicht im Kapitel "Technische Hinweise" und der Preisliste finden.

Bestellbeispiel:
für rechte Ausführung und Sorte
R015.1515-10/AL41F

More carbide grades you can find in the grades summary in the chapter "technical instructions" and in the price list.

order-example:
righthand version and grade
R015.1515-10/AL41F

ULTRAMINI

Bohrungsbearbeitung
ab $\varnothing 0.2 \text{ mm}$

grooving, boring and profiling
starting at $\varnothing 0.2 \text{ mm}$

Typ 015M

Axialstechen
mit Eckenradius

face grooving
with corner radius

D min. 8.0 mm
Stechtiefe t max. 30 mm
Nutbreite bis 3.0 mm

D min. 8.0 mm
depth of groove t max. 30 mm
width of groove up to 3.0 mm

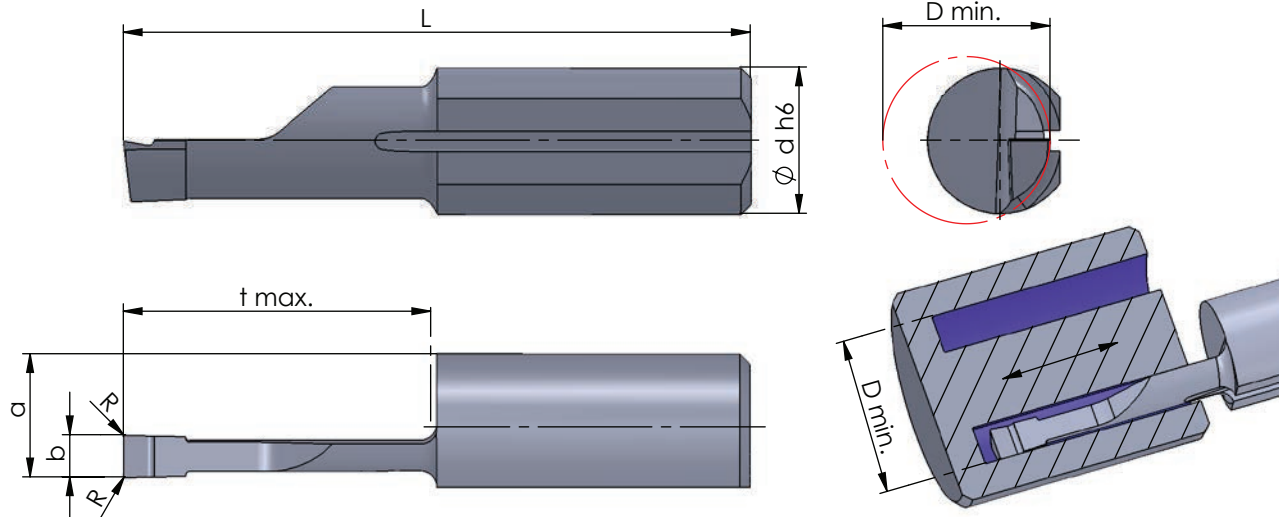

Rechts (R): wie gezeichnet
Links (L): spiegelbildlich

righthand (R): as shown
lefthand version (L): mirror image

Abmessungen in mm

dimensions in mm

Bestellnummer part number	b +0.05	a	L	t max.	D min.	$\varnothing d h6$	R	Klemmhalter Typ				toolholder type
								K10F	CN45F	AL41F	PD2F	
R/L 015M1515-10	1.5	5.9	26	10	8.0	7.0	0.1			●		
R/L 015M2015-15	2.0	5.9	30	15	8.0	7.0	0.1			●		
R/L 015M2015-20	2.0	5.9	35	20	8.0	7.0	0.1			●	670...	
R/L 015M2515-20	2.5	5.9	35	20	8.0	7.0	0.1			●	676...	...7
R/L 015M3015-20	3.0	5.9	35	20	8.0	7.0	0.1			●	687...	
R/L 015M3015-30	3.0	5.9	45	30	8.0	7.0	0.1			●		

Weitere HM Sorten können Sie in der Sortenübersicht im Kapitel "Technische Hinweise" und der Preisliste finden.

Bestellbeispiel:
für rechte Ausführung und Sorte
R015M1515-10/AL41F

More carbide grades you can find in the grades summary in the chapter "technical instructions" and in the price list.

order-example:
righthand version and grade
R015M1515-10/AL41F

ULTRAMINI

Bohrungsbearbeitung
ab $\varnothing 0.2$ mm

grooving, boring and profiling
starting at $\varnothing 0.2$ mm

Typ 012 / 016

Axialstechen
mit Eckenradius
und doppeltem Kühlkanal

face grooving
with corner radius
and double internal cooling

D min. 12 mm
Stechtiefe t max. 20 mm
Nutbreite bis 4.0 mm

D min. 12 mm
depth of groove t max. 20 mm
width of groove up to 4.0 mm

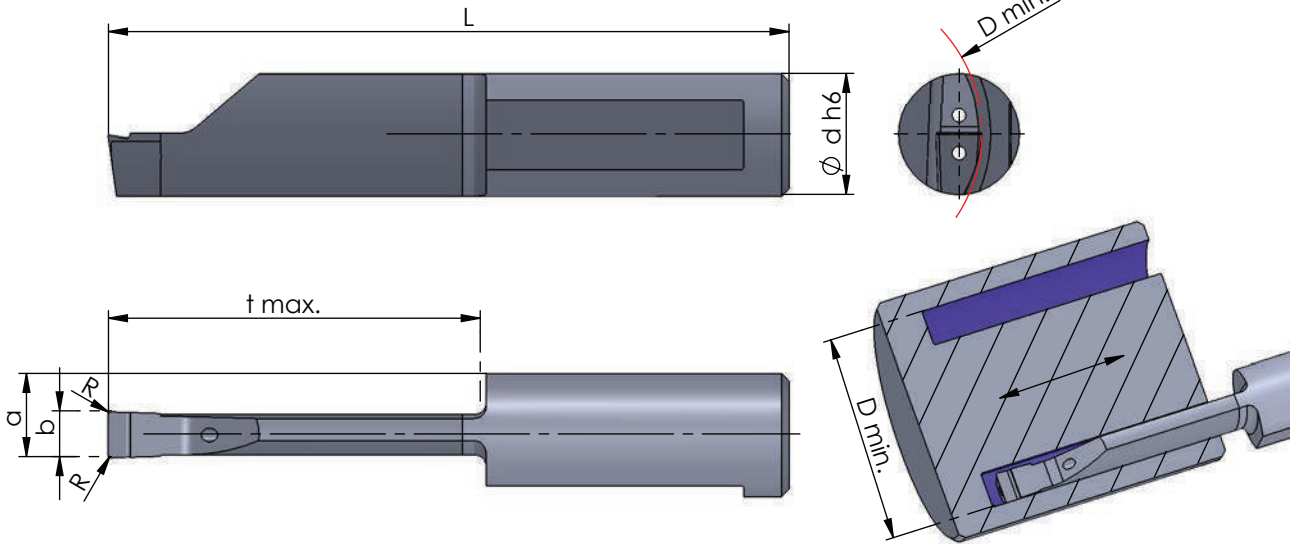

Rechts (R): wie gezeichnet
Links (L): spiegelbildlich

Kühlmitteldruckempfehlung
70 bar

Abmessungen in mm

righthand (R): as shown
lefthand version (L): mirror image

Coolant pressure recommendation
70 bar

dimensions in mm

Bestellnummer part number	b +0.05	a	L	t max.	D min.	Ø d h6	R	Klemmhalter Typ				toolholder type
								K10F	CN45F	AL41F	PD2F	
R/L 012.0200-10	2.0	5.00	30	10	12	8.0	0.2			●		680... 681... 687... ...8
R/L 012.0200-15	2.0	5.00	35	15	12	8.0	0.2			●		
R/L 012.0250-10	2.5	5.25	30	10	12	8.0	0.2			●		
R/L 012.0250-20	2.5	5.25	40	20	12	8.0	0.2			●		
R/L 016.0300-10	3.0	5.50	30	10	16	8.0	0.2		●	●		
R/L 016.0300-20	3.0	5.50	40	20	16	8.0	0.2		●	●		
R/L 016.0400-10	4.0	6.00	30	10	16	8.0	0.2		●	●		
R/L 016.0400-20	4.0	6.00	40	20	16	8.0	0.2		●	●		

Weitere HM Sorten können Sie in der Sortenübersicht im Kapitel "Technische Hinweise" und der Preisliste finden.

Bestellbeispiel:
für rechte Ausführung und Sorte
R012.0200-10/AL41F

More carbide grades you can find in the grades summary in the chapter "technical instructions" and in the price list.

order-example:
righthand version and grade
R012.0200-10/AL41F

ULTRAMINI

Bohrungsbearbeitung
ab $\varnothing 0.2$ mm

grooving, boring and profiling
starting at $\varnothing 0.2$ mm

Typ 020

Axialstechen
mit Eckenradius
und doppeltem Kühlkanal

face grooving
with corner radius
and double internal cooling

D min. 20 mm
Stechtiefe t max. 40 mm
Nutbreite bis 5.0 mm

D min. 20 mm
depth of groove t max. 40 mm
width of groove up to 5.0 mm

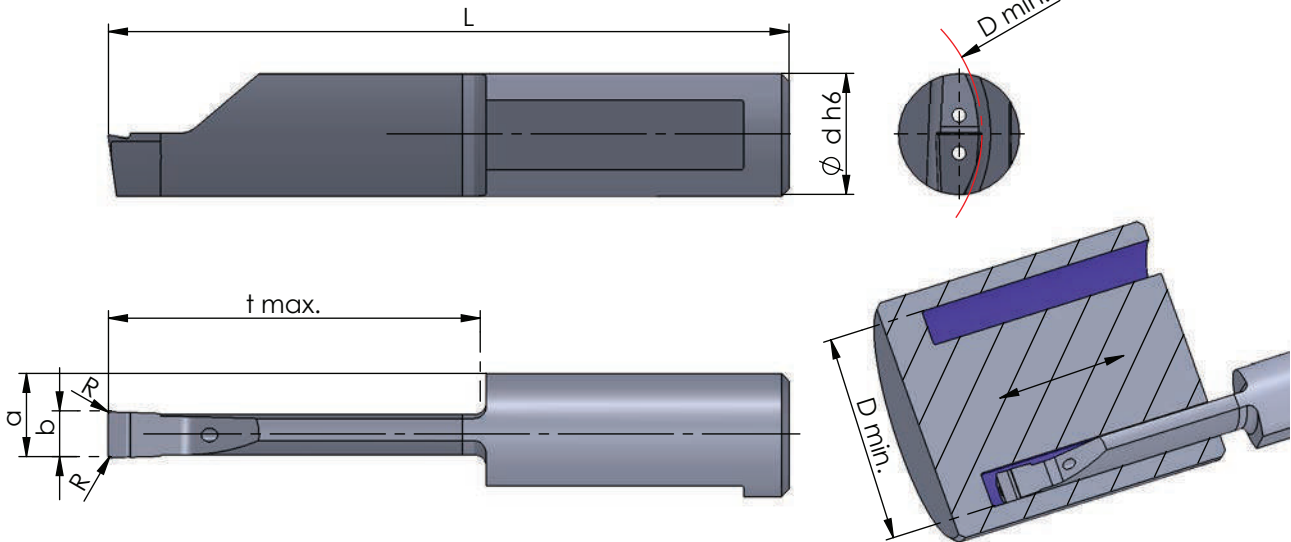

Rechts (R): wie gezeichnet
Links (L): spiegelbildlich

Kühlmitteldruckempfehlung
70 bar

Abmessungen in mm

righthand (R): as shown
lefthand version (L): mirror image

Coolant pressure recommendation
70 bar

dimensions in mm

Bestellnummer part number	b +0.05	a	L	t max.	D min.	$\varnothing d h6$	R					Klemmhalter Typ toolholder type
								K10F	CN45F	AL41F	PD2F	
R/L 020.0300-25	3.0	5.5	45	25	20	8.0	0.2			●	●	680... 681... 687... ...8
R/L 020.0300-30	3.0	5.5	50	30	20	8.0	0.2			●	●	
R/L 020.0300-35	3.0	5.5	55	35	20	8.0	0.2			●	●	
R/L 020.0300-40	3.0	5.5	60	40	20	8.0	0.2			●	●	
R/L 020.0400-25	4.0	6.0	45	25	20	8.0	0.2			●	●	
R/L 020.0400-30	4.0	6.0	50	30	20	8.0	0.2			●	●	
R/L 020.0400-35	4.0	6.0	55	35	20	8.0	0.2			●	●	
R/L 020.0400-40	4.0	6.0	60	40	20	8.0	0.2			●	●	
R/L 020.0500-20	5.0	6.5	40	20	20	8.0	0.2			●	●	
R/L 020.0500-25	5.0	6.5	45	25	20	8.0	0.2			●	●	
R/L 020.0500-30	5.0	6.5	50	30	20	8.0	0.2			●	●	
R/L 020.0500-35	5.0	6.5	55	35	20	8.0	0.2			●	●	
R/L 020.0500-40	5.0	6.5	60	40	20	8.0	0.2			●	●	

Weitere HM Sorten können Sie in der Sortenübersicht im Kapitel "Technische Hinweise" und der Preisliste finden.

Bestellbeispiel:
für rechte Ausführung und Sorte
R020.0300-25/AL41F

More carbide grades you can find in the grades summary in the chapter "technical instructions" and in the price list.

order-example:
righthand version and grade
R020.0300-25/AL41F

ULTRAMINI

Bohrungsbearbeitung
ab $\varnothing 0.2$ mm

grooving, boring and profiling
starting at $\varnothing 0.2$ mm

Typ 520

Fasen

D min. 1.0 mm
Stechtiefe t max. 4.0 mm

chamfering

D min. 1.0 mm
depth of groove t max. 4.0 mm

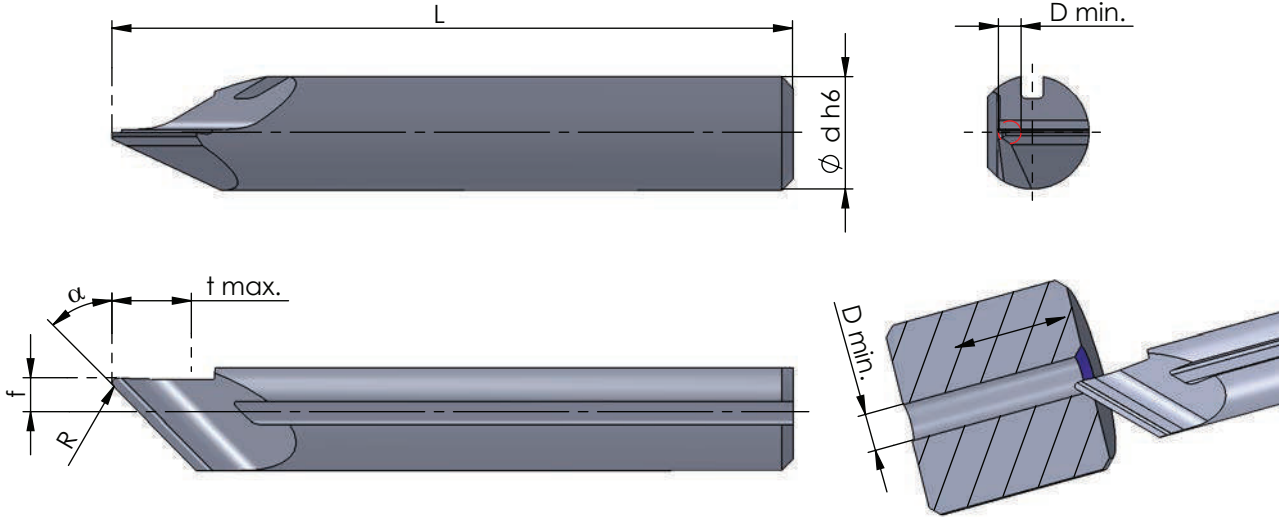

Rechts (R): wie gezeichnet
Links (L): spiegelbildlich

righthand (R): as shown
lefthand version (L): mirror image

Abmessungen in mm

dimensions in mm

Bestellnummer part number	α	f	L	t max.	D min.	$\varnothing d h6$	R	Klemmhalter Typ				toolholder type
								K10F	CN45F	AL41F	PD2F	
R/L 520.0045-15	45°	1.5	30	3.5	1.0	5.0	0.2			●		645... 650... ...5
R/L 520.0060-15	60°	1.5	30	4.0	1.0	5.0	0.2	●		●		

Weitere HM Sorten können Sie in der Sortenübersicht im Kapitel "Technische Hinweise" und der Preisliste finden.

Bestellbeispiel:
für rechte Ausführung und Sorte
R520.0045-15/AL41F

More carbide grades you can find in the grades summary in the chapter "technical instructions" and in the price list.

order-example:
righthand version and grade
R520.0045-15/AL41F

ULTRAMINI

Bohrungsbearbeitung
ab Ø 0.2 mm

grooving, boring and profiling
starting at Ø 0.2 mm

Sets



Bestellnummer part number	Inhalt Content	K10F AL41F P18C CN45F
SET.1  <ul style="list-style-type: none"> • Ausdrehen und Kopieren (Rechte Ausführung) • Ausdrehen und Fasen (Rechte Ausführung) • Stechdrehen (Rechte Ausführung) • boring and profiling (righthand version) • boring and chamfering (righthand version) • grooving (righthand version) 	Halter / toolholder: 1 x 676.0016-D 1 x 645.0016-D Schneideinsatz / insert: 1 x R050.6-22 1 x R050.5-20 1 x R060.5-20 1 x R050.4-16 1 x R050.3-16 1 x R006.0200-22 1 x R006.0150-22 1 x R005.0200-20 1 x R005.0150-20 1 x R004.0100-16	● ● ● ● ● ● ● ● ● ●

Bestellnummer part number	Inhalt Content	K10F AL41F P18C CN45F
SET.2  <ul style="list-style-type: none"> • Stechdrehen (Rechte Ausführung) • grooving (righthand version) 	Halter / toolholder: 1 x 676.0016-D 1 x 645.0016-D Schneideinsatz / insert: 1 x R006.0200-22 1 x R006.0150-22 1 x R005.0200-20 1 x R005.0150-20 1 x R004.0100-16	● ● ● ● ●

Weitere Ausführungen auf Anfrage oder in der Preisliste.

More versions on request and in the price list.

Bestellbeispiel:
SET.1

order-example:
SET.1

ULTRAMINI

Bohrungsbearbeitung
ab Ø 0.2 mm

grooving, boring and profiling
starting at Ø 0.2 mm

Sets



Bestellnummer
part number

Inhalt
Content

K10F
AL41F
P18C
CN45F

SET.3



• Ausdrehen und Kopieren
(Rechte Ausführung)

• boring and profiling
(righthand version)

Halter / toolholder:

1 x 676.0016-D
1 x 645.0016-D

Schneideinsatz / insert:

1 x R050.6-22
1 x R050.5-20
1 x R050.4-16
1 x R050.3-16

•
•
•
•

Bestellnummer
part number

Inhalt
Content

K10F
AL41F
P18C
CN45F

SET.6R



• Axialstechen
(Rechte Ausführung)

• face grooving
(righthand version)

Halter / toolholder:

1 x 676.0016-D

Schneideinsatz / insert:

1 x R010.2508-20
1 x R010.2008-10
1 x R010.1508-10
1 x R010.3008-20
1 x R010.1008-10

•
•
•
•
•

Weitere Ausführungen auf Anfrage oder in der
Preisliste.

More versions on request and in the price list.

Bestellbeispiel:
SET.3

order-example:
SET.3

ULTRAMINI

Bohrungsbearbeitung
ab \varnothing 0.2 mm

grooving, boring and profiling
starting at \varnothing 0.2 mm

Technische Hinweise

Grundsätzliche Informationen zum
Werkzeugprogramm Ultramini

Technical instructions
Basic informations about the tool pro-
gram Ultramini

Spitzenhöhe Ultramini:

Die Plattensitze der Ultramini-Werkzeuge garantieren eine exakte Position auf Spitzenhöhe. Trotzdem ist immer auf die Spitzenhöhe zu achten, denn Abweichungen können besonders bei der Bearbeitung kleinster Durchmesser Probleme bereiten.

Centre height Ultramini:

The seatings of the Ultramini tools guarantee a accurate centre height of these tools. In spite of this please have always a look at your tools because a difference may cause problems, especially when machining small diameters.



Späneabfuhr Ultramini:

Bitte wählen Sie schmale Schneidbreiten, damit der Span geschmeidig bleibt und am Werkzeug vorbei aus der Bohrung fließen kann. Um einen Spänestau zu vermeiden ist stufenförmig oder mit Schnittunterbrechung zu stechen.

Removal of chips Ultramini:

Please choose inserts with small cutting width, so the chips keep smoothly and will be able to flow out of the bore beside the tool. To avoid jam of chips use the technique to groove by steps.

Kühlmittel Ultramini:

Verwenden Sie gefiltertes Kühlmittel um die Späne auszuspülen und die Schneide zu kühlen. Ein Kühlmitteldruck von mindestens 5 bar wird empfohlen.

Coolant Ultramini:

Use filtered coolant for transporting the chips out and for cooling the insert itself. A coolant pressure of 5 bar minimum is recommended.

ULTRAMINI

Bohrungsbearbeitung
ab Ø 0.2 mm

grooving, boring and profiling
starting at Ø 0.2 mm

Technische Hinweise

Allgemeine Informationen zum
Gewindeschneiden

Technical instructions
General informations about threading



Empfohlene Anzahl der Schnitte

Die Anzahl der Schnitte ist nur ein Richtwert für das Gewindedrehen. Um eine möglichst lange Standzeit der Schneide zu erreichen beachten Sie bitte die Erklärungen für die Zustellung.

Leerschnitte zum Fertigschneiden sind in dieser Tabelle nicht berücksichtigt.

Recommended number of passes

The number of passes is only a recommendation for threading. To reach a good tool life you have to mention the explanation for the infeed.

Finishing passes are not considered in that chart.

		Stahl (Festigkeit N/mm ²) Steel (N/mm ² tensile strength)					rostfreier Stahl stainless steel	Guss cast iron	Aluminium aluminium
		400-500	500-700	700-850	850-1150	>1150			
V m/min		160	140	120	90	70	90	100	300
Steigung P Pitch P		Anzahl der Schnitte number of passes							
mm	Gg/" TPI								
0,5	48	5	5	5	5	8	8	5	5
0,8	32	6	6	6	6	8	8	6	6
1	24	7	7	7	7	8	8	7	7
1,25	20-19	8	8	8	8	10	10	8	8
1,5	16	10	10	10	10	12	12	10	10
1,75	14	12	12	12	12	14	14	12	12
2	12-11	13	13	13	13	15	15	13	13
2,5	10	15	15	16	16	18	18	16	15
3 - 3,5	8	16	16	17	17	20	20	17	16
4		18	18	19	19	22	22	19	18
5		20	20	21	21	24	24	21	20
6		22	22	23	23	26	26	23	22

ULTRAMINI

Bohrungsbearbeitung
ab $\varnothing 0.2 \text{ mm}$

grooving, boring and profiling
starting at $\varnothing 0.2 \text{ mm}$

Technische Hinweise

Allgemeine Informationen zum
Gewindeschneiden

Technical instructions
General informations about threading

Vorschubrichtung

Mit jedem Schneideinsatz für das Gewindedrehen kann sowohl ein Rechts- wie auch ein Linksgewinde geschnitten werden. Hierbei ist folgende Vorschubrichtung zu beachten:

Feed direction

Every insert can be used for right- and lefthand thread. You only have to consider the following feed direction:

Rechtsgewinde
thread right hand

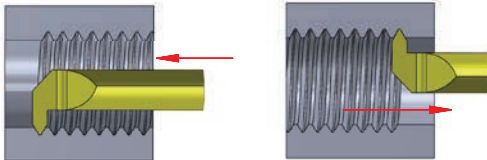

Linksgewinde
thread left hand

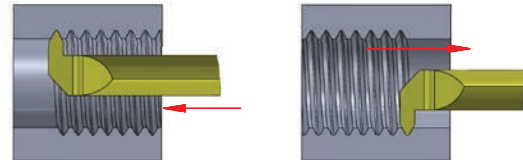

Zustellungsvarianten

Radiale Zustellung	wechselnde Flankenzustellung	einseitige Flankenzustellung
Die meist verwendete Methode um Gewinde herstellen. Beide Schneiden sind gleichzeitig im Eingriff.	Die Schneiden werden wechselnd eingesetzt.	Nur eine Schneidewird für die komplette Gewindeerstellung eingesetzt.
Problematische Spanbildung, dadurch hohe Schnittkräfte und Verschleiß am Werkzeug und Bauteil.	Reduzierung des Schnittdrucks, höhere Standzeit und bessere Spanbildung.	Reduzierung des Schnittdrucks und bessere Spanbildung, aber einseitige Abnutzung des Werkzeugs.

Infeed possibilities

Radial infeed	alternating flank infeed	flank infeed
The most used method for threading. both sides are at the same time in process.	The flanks are alternating used.	Only one cutting edge is used for the complete thread.
Problematic chip education, high cutting force and wearness at insert and work piece.	Reduced cutting force, higher state time and chip education.	Reduced cutting force and better chip education, but one-sided wearness.

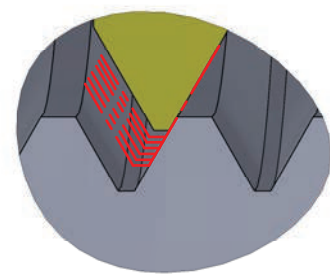
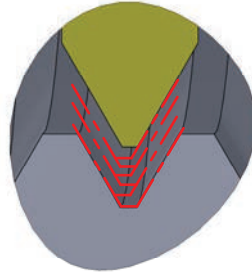
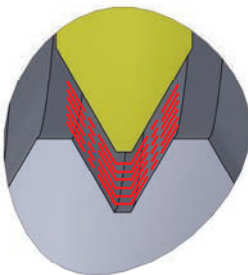

ULTRAMINI

Bohrungsbearbeitung
ab Ø 0.2 mm

grooving, boring and profiling
starting at Ø 0.2 mm

Technische Hinweise

Hartmetallsorten und Beschichtungen

Technical instructions,
carbide grades and coatings



K10F

Universell einsetzbares Feinkornhartmetall mit guter Verschleißfestigkeit. Unbeschichtet geeignet für Anwendungen mit niedrigen und mittleren Schnittgeschwindigkeiten, sowie die Bearbeitung von Nicht-eisenmetallen.

All purpose micrograin carbide with good abrasion resistance. Uncoated for applications with low or medium cutting speeds and machining of non-ferrous materials.

CBN

Zähe CBN-Sorte für Anwendungen mit niedrigen Schnittgeschwindigkeiten. Geeignet für gehärtete Stähle, unterbrochene Schnitte und Grauguss.

Ductile CBN grade for applications with lower cutting speed. Suitable for hardened steel, interrupted cuts and cast iron.

CN45F

Universell einsetzbare PVD-TiN-Beschichtung. Diese Allround-Sorte ist für niedrige und mittlere Schnittgeschwindigkeiten mit Einschränkung bei NE-Metallen

PVD-TiN coating - all purpose, all around grade is suitable for low and medium cutting speed with restrictions on non-ferrous materials.

AL41F

Sehr universell einsetzbare TiAlN-Beschichtung mit hoher Temperaturbeständigkeit bei hoher Härte. Sehr gut geeignet auch für NE-Metalle.

TiAlN coating - very universal with a high resistance to high temperature and hardness. Very suitable also for non-ferrous metals.

PD2F

Beschichtung für den universellen Einsatz bei niedrigen und mittleren Schnittgeschwindigkeiten.

Coating for universal use with medium and low speed.

XC2A

Beschichtung mit einer excellenten Warmhärte, Oxidationsbeständigkeit und thermischen Isolationsfähigkeit. Ideal für Hartzerspannung >60HRC

Coating with excellent hot hardness, high oxidation resistance and thermal insulation capacity. Perfect for hard machining >60 HRC.

ULTRAMINI

Bohrungsbearbeitung
ab \varnothing 0.2 mm

grooving, boring and profiling
starting at \varnothing 0.2 mm

Technische Hinweise

Hartmetallsorten und Beschichtungen

Technical instructions,
carbide grades and coatings

P01C

Beschichtung für die Bearbeitung in zähen Materialien bei niedrigen und mittleren Schnittgeschwindigkeiten.

Coating for the processing in tough material with medium or low cutting speed

P03C

Beschichtung für die Bearbeitung von schwer zerspanbaren Materialien. Sehr gut auch für die Trockenbearbeitung geeignet.

Coating for materials which are difficult to machine. Perfect to use for dry machining.

P07C

Beschichtung für die Bearbeitung von Titan, Edelstahl und Molybdän.

Coating to machine titanium, stainless steel and molybdenum.

P18C

Universell einsetzbare Hochleistungsschicht mit hoher Oxidationsbeständigkeit, Verschleißfestigkeit und Warmhärte.

Very universal high performance coating with high oxidation resistance, wear resistance and hot hardness resistance.

NEME

Beschichtung für die Bearbeitung von Aluminium, Al-Legierungen, NE-Metallen und Composite-Werkstoffen.

Coating for machining aluminium, alloys, non-ferrous metals and composite materials.



ULTRAMINI

Bohrungsbearbeitung
ab Ø 0.2 mm

grooving, boring and profiling
starting at Ø 0.2 mm

Technische Hinweise

Schnittdaten

Technical instructions,
cutting data



	Werkstoff	Festigkeit	Werkstoff-Nr	Werkstoffbezeichnung	Werkstoff-Nr
P	Allgemeiner Baustahl	< 800 N/mm2	1.0037	St37-2	1.0570
	Automatenstahl	< 800 N/mm2	1.0718	9SMnPb28	1.0727
	Einsatzstahl unlegiert	< 800 N/mm2	1.0401	C15	1.0481
	Einsatzstahl legiert	< 1000 N/mm2	1.7331	16MnCr5 (EC80)	1.7015
	Vergütungsstahl unlegiert	< 850 N/mm2	1.0503	C45	1.1191
	Vergütungsstahl unlegiert	< 1000 N/mm2	1.0601	C60	1.1221
	Vergütungsstahl legiert	< 800 N/mm2	1.5131	50MnSi4	1.7030
	Vergütungsstahl legiert	< 1300 N/mm2	1.5755	31NiCr14	1.7033
	Stahlguss	< 850 N/mm2	0.9650	G-X260Cr27	1.6750
	Nitrierstahl	< 1000 N/mm2	1.8504	34CrAl6	1.8507
	Nitrierstahl	< 1200 N/mm2	1.8515	31CrMo12	1.8523
	Wälzlagerstahl	< 1200 N/mm2	1.3505	100Cr6 (W3)	1.3543
	Federstahl	< 1200 N/mm2	1.5026	55Si7	1.7176
	Schnellarbeitsstahl	< 1300 N/mm2	1.3344	S 6-5-3	1.3255
	Werkzeugstahl für Kaltarbeit	< 1300 N/mm2	1.2312	40CrMnMoS8 6	1.2379
	Werkzeugstahl für Warmbeit	< 1300 N/mm2	1.2343	X38CrMoV 5 1	1.2767
M	Stahl und Stahlguss rostfrei geschwefelt	< 850 N/mm2	1.4305	X8CrNiS18 9	1.4105
	Nichtrostender Stahl, ferritisch	< 750 N/mm2	1.4510	X3CrTi17	1.4528
	Nichtrostender Stahl, martensitisch	< 900 N/mm2	1.4034	X46Cr13	1.4116
	Nichtrost. Stahl, ferritisch/martensit.	<1100 N/mm2	1.4313	X3CrNi13-4	1.4028
	Nichtrost. Stahl, austenitisch/ferritisch	< 850 N/mm2	1.4460	X8CrNiMo27 5	1.4821
	Nichtrostender Stahl, austenitisch	< 750 N/mm2	1.4301	X5CrNi18-10	1.4571
K	Hitzebeständig	< 1100 N/mm2	1.4747	X80CrNiSi20	1.4876
	Grauguss mit Lammellengraphit	100-350N/mm2	0.6010	GG10	0.6025
	Grauguss mit Lammellengraphit	300-1000N/mm2	0.6030	GG30	0.6045
	Kugelgraphitguss	300-500N/mm2	0.7040	GGG40	0.7050
	Kugelgraphitguss	550-800N/mm2	0.7060	GGG60	0.7080
	Temperguss weis	350-450N/mm2	0.8035	GTW35	0.8045
	Temperguss weis	500-650N/mm2	0.8055	GTW55	0.8065
	Temperguss schwarz	350-450N/mm2	0.8135	GTS35	0.8145
N	Temperguss schwarz	500-700N/mm2	0.8155	GTS55	0.8170
	Aluminium (unlegiert, niedrig legiert)	< 350 N/mm2	3.0255	Al99,5	3.3308
	Aluminiumlegierungen < 0,5% Si	< 500 N/mm2	3.0515	AlMn1	3.1355
	Aluminiumlegierungen 0,5-10% Si	< 400 N/mm2	3.2152	GD-AlSi6Cu4	3.2373
	Aluminiumlegierungen 10-15% Si	< 400 N/mm2	3.2381	G-AlSi10Mg	3.5562
	Aluminiumlegierungen > 15% Si	< 400 N/mm2		G-AlSi17Cu4	
	Kupfer (unlegiert, niedrig legiert)	< 350 N/mm2	2.0060	E-Cu57	2.0090
	Kupfer-Knetlegierungen	< 700 N/mm2	2.0240	CuZn15	2.0265
	Kupfer-Sonderlegierungen	< 200 HB	2.0916	CuAl5	2.1525
	Kupfer-Sonderlegierungen	< 300HB	2.0978	CuAl11Ni6Fe5	
	Kupfer-Sonderlegierungen	> 300 HB	2.1247	CuBe2F125	
	Messing kurzspanend, Bronze, Rotguss	< 600 N/mm2	2.0360	CuZn40 (Ms60)	2.0380
	Messing langspanend	< 600 N/mm2	2.0335	CuZn36 (Ms63)	2.1293
	Thermoplaste			Delrin, Hostalen	
	Duroplaste			Ferrozell, Bakelit	
	Faserverstärkte Kunststoffe			GFK (Glasfaserverstärkt)	
	Magnesium und Magnesiumlegierungen	< 850 N/mm2	3.5200	M2, MgMn2	3.5612
	Graphit			C8000, R8500X	
	Wolfram und Wolframlegierungen			W-NiFe (Densimet W)	
Molybdän und Molybdänlegierungen			Mo , Mo-50Re		
S	Reinnickel		1.3911	RNi24	1.3927
	Nickellegierungen		1.3912	Ni36 (Invar)	1.3924
	Nickellegierungen	< 850 N/mm2	2.4360	S-NiCu 30 Fe	
	Nickel-Chromlegierungen		2.4886	SG-NiMo16Cr16W	2.4610
	Nickel- und Kobaltlegierungen	< 1300 N/mm2	2.4632	NiCr20Co18Ti	2.4631
	Nickel- und Kobaltlegierungen	< 1300 N/mm2	2.4634	NiCo20Cr15MoAlTi	2.4654
	Hochwarmfeste Legierungen	< 1300 N/mm2		Hardox 400	1.4939
	Nickel-Kobalt-(Chrom-)legierungen	< 1400 N/mm2	2.4806	SG-NiCr20Nb, Inconel 82	2.4851
	Reintitan	< 900 N/mm2	3.7025	Ti99,8	3.7034
	Titanlegierungen	< 700 N/mm2	3.7114	TiAl5Sn2	3.7174
H	Titanlegierungen	< 1200 N/mm2	3.7164	TiAl5V4	3.7144
	Stahl gehärtet	< 45 HRc			
		46-55HRc			
		56-60 HRc			
	61-65 HRc				
	65-70 HRc				

Vorschub f:

Stechdrehen: 0,01 - 0,03 mm/U

Ausdrehen / Kopieren: 0,02 - 0,08 mm/U

Axialstechen: 0,02 - 0,05 mm/U

feed f:

grooving: 0,01 - 0,03 mm/Rev.

boring / profiling: 0,02 - 0,08 mm/Rev.

face grooving: 0,02 - 0,05 mm/Rev.

ULTRAMINI

Bohrungsbearbeitung
ab Ø 0.2 mm

grooving, boring and profiling
starting at Ø 0.2 mm

Technische Hinweise

Schnittdaten

Technical instructions,
cutting data



Werkstoffbez.	Werkstoff-Nr	Werkstoffbez.	Vc K10F (m/min.)	Vc CN45F (m/min.)	Vc AL41F (m/min.)	Vc P18C (m/min.)	Vc P07C (m/min.)	Vc XC2A-NH (m/min.)
St52-3	1.0060	St60-2	30-130	30-180	80-200	80-200	80-200	
45S20	1.0757	46SPb2	30-130	40-200	80-200	80-200	80-200	
17Mn4	1.1141	C15E (CK15)	30-130	40-180	80-200	80-200	80-200	
13Cr3 (EC60)	1.5919	15CrNi6	15-90	30-140	80-160	80-160	80-160	
Ck45	1.0535	C55	15-90	30-100	80-140	80-140	80-140	
Ck60	1.0540	C50	15-90	30-100	80-160	80-160	80-160	
28Cr4	1.7225	42CrMo4	30-130	30-100	80-160	80-160	80-160	
34Cr4	1.3565	48CrMo4	15-90	30-100	80-150	80-150	80-150	
G5-20NiCrMo3 7	1.6582	G5-34 CrNiMo 6	30-130	40-200	80-200	80-200	80-200	
34AlMo5	1.8509	41CrAlMo7	15-90	30-100	70-140	70-140	70-140	
39CrMoV19 3	1.8550	34 CrAlNi 7	15-90	30-100	70-140	70-140	70-140	
X192CrMo17	1.3520	100 CrMn 6 (W4)	15-90	30-100	70-140	70-140	70-140	
55Cr3	1.7701	51CrMoV4						
S 18-1-2-5	1.3294	PMH56-5-3-8; ASP30						
X155CrVMo12 1	1.2316	X38CrMo16; RAMAX	15-45	30-100				
X45NiCrMo4	1.2842	90MnCrV8	15-45	30-100				
X4CrMoS18	1.4107	GX8CrNi12		30-100	80-160	80-160	80-160	
X105CrCoMo18 2	1.4016	X6Cr17		30-100	80-160	80-160	80-160	
X50CrMoV15	1.4106	X2CrMoSiS18-2-1		30-100	80-160	80-160	80-160	
X30Cr13	1.4104	X14CrMoS17		20-90	20-85	20-85	20-85	
X20CrNiSi25 4	1.4462	X2CrNiMoN22-5-3(Duplex)		20-65	20-75	20-75	20-75	
X6CrNiMoTi17 12 2	1.4449	X3CrNiMo18-12-3		20-80	20-65	20-65	20-65	
X10NiCrAlTi32-21	1.4825	GX25CrNiSi18-9		20-80	20-65	20-65	20-65	
GG25			30-110	70-150	30-180	30-180	30-180	
GG45			30-90	50-120	30-150	30-150	30-150	
GGG50			25-110	30-130	30-180	30-180	30-180	
GGG80			25-80	30-110	30-120	30-120	30-120	
GTW45			30-110	30-100	30-90	30-90	30-90	
GTW65			30-90	30-90	20-80	20-80	20-80	
GTS45			30-110	30-100	30-90	30-90	30-90	
GTS70			30-90	30-90	20-80	20-80	20-80	
Al99,9Mg0,5	3.0256	E-Al H	110-210	100-600	120-600	120-600	120-600	
AlCuMg2	3.3315	AlMg1	90-200	100-600	120-600	120-600	120-600	
GD-ALSi9Mg	3.2134	GD-ALSi5Cu1Mg	90-200	100-500	100-450	100-450	100-450	
G-MgAl6	3.2525	S-ALSi12	50-140	80-350	70-300	70-300	70-300	
G-ALSi25CuNiMg		G-ALSi21CuNiMg		80-200	60-150	60-150	60-150	
SF-Cu	2.1522	CuSi2Mn	50-140	70-160	60-150	60-150	60-150	
CuZn30	2.0321	CuZn37	60-150	80-180	100-180	100-180	100-180	
CuSi3Mn		Ampco 8-16	50-140	80-180	90-180	90-180	90-180	
		Ampco18-26	50-140	80-180	80-180	80-180	80-180	
		Ampco M-4	50-140	80-180	80-180	80-180	80-180	
CuZn39Pb2 (Ms58)	2.0410	CuZn44Pb2	80-160	100-200	120-220	120-220	120-220	
CuCrZr	2.1080	CuSn6Zn6	50-120	80-180	70-150	70-150	70-150	
Makrolon, Novodur		Acrylglas, Polystyrol	40-120	70-160	80-180	80-180	80-180	
Pertinax		Resopal						
CFK (Kohlefaserverstärkt)		AFK (Amidfaserverstärkt)						
MgAl6Zn1	3.5812	MgAl8Zn1						
R8650		Technograph15						
W-Cu80/20		W93NiFe (DENAL)	15-70					
TZC, TZM		MHC , ODS						
RNi8	1.3926	RNi12		30-80	30-80	30-80	30-80	
Ni54	1.3921	Ni49		18-75	18-75	18-75	18-75	
NiCu 30 Fe		Monel 400		18-75	18-75	18-75	18-75	
NiMo16Cr16Ti		Hastelloy C-276			40-70	40-70	40-70	60 - 70
NiCr20TiAl		Nimonic 80		18-40	40-70	40-70	40-70	60 - 70
NiCr19Co14Mo4Ti		Waspaloy		18-40	40-70	40-70	40-70	60 - 70
X12CrNiMo12	1.4980	X6NiCrTiMoVB25-15-2		15-30	40-70	40-70	40-70	60 - 70
NiCr23Fe, Inconel 601	2.4667	SG-NiCr19NbMoTi		15-30	40-70	40-70	40-70	60 - 70
Ti99,7	3.7064	Ti99,5			40-70	40-70	70-150	
TiAl6V6Sn2	3.7124	TiCu2			40-70	40-70	70-150	
TiAl6Sn2Zr4Mo2	3.7154	TiAl6Zr5			40-70	40-70	70-150	
								50 - 120
								50 - 120
								50 - 120

Vorschub f:

Stechdrehen:	0,01 - 0,03 mm/U
Ausdrehen / Kopieren:	0,02 - 0,08 mm/U
Axialstechen:	0,02 - 0,05 mm/U

feed f:

grooving:	0,01 - 0,03 mm/Rev.
boring / profiling:	0,02 - 0,08 mm/Rev.
face grooving:	0,02 - 0,05 mm/Rev.

ULTRAMINI

Bohrungsbearbeitung
ab Ø 0.2 mm

grooving, boring and profiling
starting at Ø 0.2 mm

Technische Hinweise

Schnittdaten

Technical instructions,
cutting data



	MATERIAL	STRENGTH (psi)	MATERIAL NUMBER	MATERIAL DESCRIPTION	ANSI	MATERIAL NUMBER	MATERIAL DESCRIPTION
P	General Construction Steel	< 116030	1.0037	St37-2	A284	1.0570	St52-3
	Free-cutting steel	< 116030	1.0718	95MnPb28	12L13	1.0727	45S20
	Non-Alloyed Steel	< 116030	1.0401	C15	1015	1.0481	17Mn4
	Alloy Steel	< 145038	1.7331	16MnCr5 (EC80)	5120	1.7015	13Cr3 (EC60)
	Compensation Steel Unalloyed	< 123282	1.0503	C45	1045	1.1191	Ck45
	Compensation Steel Unalloyed	< 145038	1.0601	C60	1060	1.1221	Ck60
	Alloy Steel	< 116030	1.5131	50MnSi4		1.7030	28Cr4
	Alloy Steel	< 188549	1.5755	31NiCr14		1.7033	34Cr4
	Cast Steel	< 123282	0.9650	G-X260Cr27		1.6750	GS-20NiCrMo3 7
	Nitriding Steel	< 145038	1.8504	34CrAl6		1.8507	34AlMo5
	Nitriding Steel	< 174045	1.8515	31CrMo12		1.8523	39CrMoV19 3
	Bearing Steel	< 174045	1.3505	100Cr6 (W3)	52100	1.3543	X192CrMo17
	Bearing Steel	< 174045	1.5026	55Si7	-	1.7176	55Cr3
	High Speed Steel	< 188549	1.3344	S 6-5-3		1.3255	S 18-1-2-5
	Tool Steel for Cold Work	< 188549	1.2312	40CrMnMoS8 6		1.2379	X155CrVMo12 1
Tool Steel for Warm Work	< 188549	1.2343	X38CrMoV 5 1	H11	1.2767	X45NiCrMo4	
M	Steel and cast steel rostfrei sulfurized	< 123282	1.4305	X8CrNiS18 9	303	1.4105	X4CrMoS18
	Stainless Steel, Ferritic	< 108778	1.4510	X3CrTi17		1.4528	X105CrCoMo18 2
	Stainless Steel, Martensitic	< 130534	1.4034	X46Cr13	-	1.4116	X50CrMoV15
	Non-rusting. Steel, Ferritic / Martensite	< 159542	1.4313	X3CrNi13-4		1.4028	X30Cr13
	Non-rusting. Steel, Austenitic / Ferritic	< 123282	1.4460	X8CrNiMo27 5	S32900	1.4821	X20CrNiSi25 4
	Stainless Steel, Austenitic	< 108778	1.4301	X5CrNi18-10	304	1.4571	X6CrNiMoTi17 12 2
	Heat Resistant	< 159542	1.4747	X80CrNiSi20		1.4876	X10NiCrAlTi32-21
K	Gray Cast Iron with Lamellar Graphite	14504-50763	0.6010	GG10	CLASS20	0.6025	GG25
	Gray Cast Iron with Lamellar Graphite	43511-145038	0.6030	GG30	CLASS45	0.6045	GG45
	Ball Graphite Castings	43511-72519	0.7040	GGG40	60-40-18	0.7050	GGG50
	Ball Graphite Castings	79771-116030	0.7060	GGG60	-	0.7080	GGG80
	Malleable Cast Iron	50763-65367	0.8035	GTW35	-	0.8045	GTW45
	Malleable Cast Iron	72519-94274	0.8055	GTW55	-	0.8065	GTW65
	Malleable Cast Iron Black	50763-65267	0.8135	GTS35	32510	0.8145	GTS45
	Malleable Cast Iron Black	72519-101526	0.8155	GTS55	50005	0.8170	GTS70
N	Aluminum (unalloyed, low alloy)	< 50763	3.0255	Al99,5	1000	3.3308	Al99,9Mg0,5
	Aluminum Alloys < 0,5%	< 72519	3.0515	AlMn1		3.1355	AlCuMg2
	Aluminum Alloys 0,5-10%	< 58015	3.2152	GD-AlSi6Cu4		3.2373	GD-AlSi9Mg
	Aluminum Alloys 10-15%	< 58015	3.2381	G-AlSi10Mg	-	3.5562	G-MgAl6
	Aluminum Alloys > 15%	< 58015		G-AlSi17Cu4			G-AlSi25CuNiMg
	Copper (unalloyed, low alloy)	< 50763	2.0060	E-Cu57		2.0090	SF-Cu
	Copper Wrought Alloys	< 101526	2.0240	CuZn15	C23000	2.0265	CuZn30
	Copper Special Alloys	< 200 HB	2.0916	CuAl5		2.1525	CuSi3Mn
	Copper Special Alloys	< 300HB	2.0978	CuAl11Ni6Fe5			
	Copper Special Alloys	> 300 HB	2.1247	CuBe2F125			
	Brass Short-Spanning, Bronze, Gunmetal	< 87023	2.0360	CuZn40 (Ms60)	C28000	2.0380	CuZn39Pb2 (Ms58)
	Brass Long-Spanning	< 87023	2.0335	CuZn36 (Ms63)	C36000	2.1293	CuCrZr
	Thermoplastics			Delrin, Hostalen			Makrolon, Novodur
	Thermosets			Ferrozell, Bakelit			Pertinax
	Fiber Reinforced Plastics			GFK (Glasfaserverstärkt)			CFK (Kohlefaserverstärkt)
	Magnesium and Magnesium Alloys	< 123282	3.5200	M2, MgMn2		3.5612	MgAl6Zn1
	Graphite			C8000, R8500X			R8650
Tungsten and Tungsten Alloys			W-NiFe (Densimet W)			W-Cu80/20	
Molybdenum and Molybdenum Alloys			Mo, Mo-50Re			TZC, TZM	
S	Pure Nickel		1.3911	RNi24		1.3927	RNi8
	Nickel Alloys		1.3912	Ni36 (Invar)		1.3924	Ni54
	Nickel Alloys	< 123282	2.4360	S-NiCu 30 Fe			NiCu 30 Fe
	Nickel-Chromium Alloy		2.4886	SG-NiMo16Cr16W		2.4610	NiMo16Cr16Ti
	Nickel and Cobalt Alloys	< 188549	2.4632	NiCr20Co18Ti		2.4631	NiCr20TiAl
	Nickel and Cobalt Alloys	< 188549	2.4634	NiCo20Cr15MoAlTi		2.4654	NiCr19Co14Mo4Ti
	High-Temperature Resistant Alloys	< 188549		Hardox 400		1.4939	X12CrNiMo12
	Nickel-Cobalt-(Chrome-) Alloys	< 203053	2.4806	SG-NiCr20Nb, Inconel 82		2.4851	NiCr23Fe, Inconel 601
	Pure Titanium	< 130534	3.7025	Ti99,8		3.7034	Ti99,7
	Titanium Alloys	< 101526	3.7114	TiAl5Sn2	-	3.7174	TiAl6V6Sn2
Titanium Alloys	< 174045	3.7164	TiAl5V4		3.7144	TiAl6Sn2Zr4Mo2	
H	Hardened Steel	< 45 HRC					
		46-55HRC					
		56-60 HRC					
		61-65 HRC					
	65-70 HRC						

Data on this page is for reference and planning only. Materials and processes should be tested in your environment to achieve desired results.

feed f:

groove: 0.0004 - 0.0012 in/Rev.

copy turning: 0.0008 - 0.0031 in/Rev.

axial groove: 0.0008 - 0.002 in/Rev.

ULTRAMINI

Bohrungsbearbeitung
ab Ø 0.2 mm

grooving, boring and profiling
starting at Ø 0.2 mm

Technische Hinweise

Schnittdaten

Technical instructions,
cutting data



ANSI	MATERIAL NUMBER	MATERIAL DESCRIPTION	ANSI	K10F (SFM)	CN45F (SFM)	AL41F (SFM)	P18C (SFM)	P07C (SFM)	XC2A-NH (SFM)
	1.0060	St60-2	A572	98-426	98-591	262-656	262-656	262-656	
	1.0757	46SPb2		98-426	131-656	262-656	262-656	262-656	
	1.1141	C15E (CK15)	1015	98-426	131-591	262-656	262-656	262-656	
	1.5919	15CrNi6	3115	49-295	98-459	262-525	262-525	262-525	
1045	1.0535	C55	1055	49-295	98-328	262-459	262-459	262-459	
1060	1.0540	C50		49-295	98-328	262-525	262-525	262-525	
	1.7225	42CrMo4	4140	98-426	98-328	262-525	262-525	262-525	
5132	1.3565	48CrMo4		49-295	98-328	262-492	262-492	262-492	
	1.6582	GS-34 CrNiMo 6	4337	98-426	131-656	262-656	262-656	262-656	
	1.8509	41CrAlMo7	A355	49-295	98-328	230-459	230-459	230-459	
	1.8550	34 CrAlNi 7		49-295	98-328	230-459	230-459	230-459	
	1.3520	100 CrMn 6 (W4)		49-295	98-328	230-459	230-459	230-459	
	1.7701	51CrMoV4							
1015	1.3294	PMH56-5-3-8; ASP30							
D2	1.2316	X38CrMo16; RAMAX		49-148	98-328				
	1.2842	90MnCrV8	02	49-148	98-328				
430F	1.4107	GX8CrNi12			98-328	262-525	262-525	262-525	
	1.4016	X6Cr17	430		98-328	262-525	262-525	262-525	
	1.4106	X2CrMoSi18-2-1			98-328	262-525	262-525	262-525	
420F	1.4104	X14CrMoS17	430 F		66-295	66-279	66-279	66-279	
	1.4462	X2CrNiMoN22-5-3 (Duplex)	UNS31803		66-213	66-246	66-246	66-246	
316 Ti	1.4449	X3CrNiMo18-12-3	317		66-262	66-213	66-213	66-213	
B163	1.4825	GX25CrNiSi18-9			66-262	66-213	66-213	66-213	
A48-40 B				98-361	230-492	98-591	98-591	98-591	
				98-295	164-394	98-492	98-492	98-492	
65-45-12				82-361	98-426	98-591	98-591	98-591	
120-90-02				82-262	98-361	98-394	98-394	98-394	
				98-361	98-328	98-295	98-295	98-295	
				98-295	98-295	66-262	66-262	66-262	
				98-361	98-328	98-295	98-295	98-295	
				98-295	98-295	66-262	66-262	66-262	
	3.0256	E-Al H		361-689	328-1969	394-1968	394-1969	394-1969	
2024	3.3315	AlMg1		295-656	328-1969	394-1968	394-4969	394-1969	
	3.2134	GD-AlSi5Cu1Mg		295-656	328-1640	328-1476	328-1476	328-1476	
	3.2525	S-AlSi12		164-459	262-1148	230-984	230-984	230-984	
		G-AlSi21CuNiMg			262-656	197-492	197-492	197-492	
	2.1522	CuSi2Mn		164-459	230-525	197-492	197-492	197-492	
	2.0321	CuZn37		197-492	262-591	328-591	328-591	328-591	
		Ampco 8-16		164-459	262-591	295-591	295-591	295-591	
		Ampco18-26		164-459	262-591	262-591	262-591	262-591	
		Ampco M-4		164-459	262-591	262-591	262-591	262-591	
	2.0410	CuZn44Pb2		262-525	328-656	394-722	394-722	394-722	
	2.1080	CuSn6Zn6		164-394	262-591	230-492	230-492	230-492	
		Acrylglas, Polystyrol		131-394	230-525	262-591	262-591	262-591	
		Resopal							
		AFK (Amidfaserverstärkt)							
	3.5812	MgAl8Zn1							
		Technograph15							
		W93NiFe (DENAL)		49-230					
		MHC , ODS							
	1.3926	RNi12			98-262	98-262	98-262	98-262	
	1.3921	Ni49			59-246	59-246	59-246	59-246	
		Monel 400			59-246	59-246	59-246	59-246	
		Hastelloy C-276				131-230	131-230	131-230	197-230
		Nimonic 80			59-131	131-230	131-230	131-230	197-230
		Waspaloy			59-131	131-230	131-230	131-230	197-230
904L	1.4980	X6NiCrTiMoVB25-15-2			49-98	131-230	131-230	131-230	197-230
	2.4667	SG-NiCr19NbMoTi			49-98	131-230	131-230	131-230	197-230
	3.7064	Ti99,5				131-230	131-230	230-192	
	3.7124	TiCu2				131-230	131-230	230-192	
	3.7154	TiAl6Zr5				131-230	131-230	230-192	
									164-394
									164-394
									164-394

Data on this page is for reference and planning only. Materials and processes should be tested in your environment to achieve desired results.

feed f:

groove: 0.0004 - 0.0012 in/Rev.

copy turning: 0.0008 - 0.0031 in/Rev.

axial groove: 0.0008 - 0.002 in/Rev.

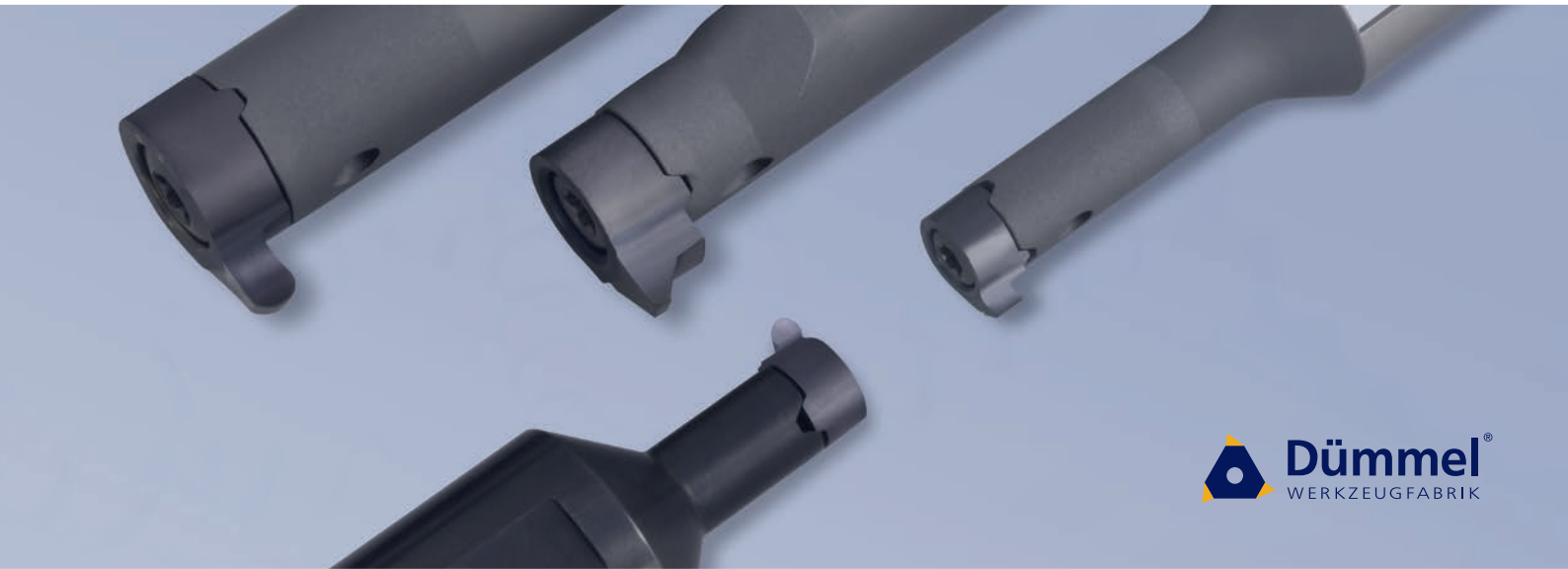

MINICUT



Bohrungsbearbeitung ab Ø 7.8 mm

**Grooving, boring and profiling
starting at Ø 7.8 mm**

MINICUT

Bohrungsbearbeitung

grooving, boring and profiling

Übersicht

summary



Allgemeine Beschreibung

general instructions

... 123

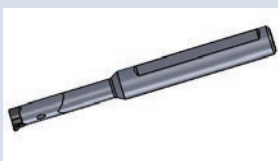

**Klemmhalter
Rundschaft**

**tool holder
straight shank**

**Maße
dimensions**

**Seite
page**

Typ 608 / 609 / 611 / 614	Klemmhalter Stahl	tool holder steel	D min. 7.8	... 124
Typ 616 / 618	Klemmhalter Stahl	tool holder steel	D min. 16	... 125
Typ 608 / 609	Klemmhalter Hartmetall	tool holder carbide	D min. 7.8	... 126
Typ 611	Klemmhalter Hartmetall	tool holder carbide	D min. 11	... 127
Typ 614	Klemmhalter Hartmetall	tool holder carbide	D min. 14	... 128
Typ 616	Klemmhalter Hartmetall	tool holder carbide	D min. 16	... 129
Typ 618	Klemmhalter Hartmetall	tool holder carbide	D min. 18	... 130
Typ V08 / V11	Flexohalter V	Flexo-toolholder V	D min. 8 / 11	...131
Typ 614.A / 618.A	Klemmhalter Axialbearbeitung	tool holder face grooving	D min. 12 / 14 / 16 / 18	... 132

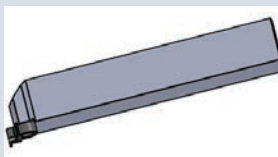

**Klemmhalter
Quadratschaft**

**tool holder
square shank**

**Maße
dimensions**

**Seite
page**

Typ 614.SQ / 618.SQ	Klemmhalter Stahl, Quadratschaft Axialbearbeitung	tool holder steel, square shank face grooving	D min. 12 / 14 / 16 / 18	... 133
Typ 614.SQ.A / 618.SQ.A	Klemmhalter Stahl, Quadratschaft Axialbearbeitung, abgesetzte Version	tool holder steel, square shank face grooving with offset	D min. 12 / 14 / 16 / 18	... 134

MINICUT

Bohrungsbearbeitung

grooving, boring and profiling

Übersicht

summary

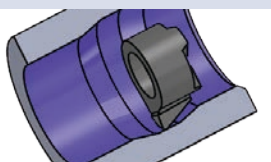

Schneideinsätze Ausdrehen und Kopieren

inserts boring and profiling

Maße dimensions

Seite page

Typ Ausdrehen und Kopieren	allgemein	type boring and profiling, general	D min. 7.8 - 15.5	... 136
Typ Ausdrehen und Kopieren	von gehärteten Teilen mit CBN	type boring and profiling, of hardened parts with CBN	D min. 7.8 - 15.5	... 137
Typ Ausdrehen und Kopieren	allgemein, Innenfreistriche DIN 509	type boring and profiling, general, undercuts DIN 509	D min. 7.8 - 20	... 138
Typ Ausdrehen und Kopieren	Ausdrehen mit spezieller Spantreppe	type boring and profiling, boring with special chipbreaker	D min. 8 / 9 / 11 t max. 0.5	... 139
Typ Ausdrehen und Kopieren	Rückwärtsdrehen	type boring and profiling, backboring	D min. 7.8 - 13.8	... 140

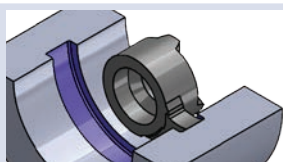

Schneideinsätze Stechdrehen

inserts grooving

Maße dimensions

Seite page

Typ Stechdrehen	für Sicherungsringe DIN 471/472 und Stechdrehen allgemein	type grooving, for circlips DIN 471/472 and grooving	D min. 8	... 142
Typ Stechdrehen	für Sicherungsringe DIN 471/472 und Stechdrehen allgemein	type grooving, for circlips DIN 471/472 and grooving	D min. 9	... 143
Typ Stechdrehen	für Sicherungsringe DIN 471/472 und Stechdrehen allgemein	type grooving, for circlips DIN 471/472 and grooving	D min. 11	... 144
Typ Stechdrehen	für Sicherungsringe DIN 471/472 und Stechdrehen allgemein	type grooving, for circlips DIN 471/472 and grooving	D min. 14	... 145
Typ Stechdrehen	für Sicherungsringe DIN 471/472 und Stechdrehen allgemein	type grooving, for circlips DIN 471/472 and grooving	D min. 16	... 146
Typ Stechdrehen	Stechdrehen allgemein	type grooving, general use	D min. 18 / 20 t max. = 6 / 8	... 147
Typ Stechdrehen	Stechdrehen allgemein, große Einstechtiefe	type grooving, general use, maximum depth of groove	D min. 16 / 17 t max. = 5.5 / 6.5	... 148

↳ ...

MINICUT

Bohrungsbearbeitung

grooving, boring and profiling

Übersicht

summary

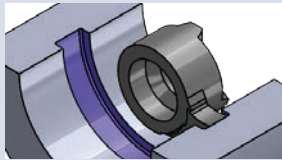

Schneideinsätze Stechdrehen

inserts grooving

Maße dimensions

Seite page

... ↴

Typ Stechdrehen	NC-Feindrehen	type grooving, NC-profiling	D min. 8 - 16	... 149
Typ Stechdrehen	NC-Feindrehen, große Einstechtiefe	type grooving, NC-profiling, maximum depth of groove	D min. 16 / 17 t max. = 5.5 / 6.5	... 152
Typ Stechdrehen	Stechdrehen und Kopieren Vollradius	type grooving, grooving and profiling, full radius	D min. 8 - 16 R 0.4 - 2.0	... 153
Typ Stechdrehen	Ausdrehen und Fasen	type grooving, boring and chamfering	D min. 8 - 14	... 156
Typ Stechdrehen	Vorstechen und Fasen	type grooving, pregrooving and chamfering	D min. 8 - 16	... 157



Schneideinsätze Gewindedrehen, innen

inserts threading, internal

Maße dimensions

Seite page

Typ Gewindedrehen	metrisches ISO-Gewinde, Teilprofil, innen	type threading, metric ISO-thread, partial profile, internal	D min. 8 / 9 P = 0.5 - 3.5	... 158
Typ Gewindedrehen	metrisches ISO-Gewinde, Teilprofil, innen	type threading, metric ISO-thread, partial profile, internal	D min. 11 / 14 / 16 P = 0.5 - 3.0	... 159
Typ Gewindedrehen	metrisches ISO-Gewinde, Vollprofil, innen	type threading, metric ISO-thread, full profile, internal	D min. 9 / 11 P = 0.5 - 3.0	... 160
Typ Gewindedrehen	metrisches ISO-Gewinde, Vollprofil, innen	type threading, metric ISO-thread, full profile, internal	D min. 14 / 16 P = 0.5 - 4.0	... 161
Typ Gewindedrehen	NPT Vollprofil, innen	type threading, NPT full profile, internal	D min. 8	... 162
Typ Gewindedrehen	Whitworth-Gewinde, Vollprofil, innen	type threading, Whitworth thread, full profile, internal	D min. 11 / 14 / 16	... 163
Typ Gewindedrehen	Trapezgewinde, Teilprofil, innen	type threading, trapezoidal thread, partial profile, internal	D min. 9 / 10 / 11 P = 1.5 - 4.0	... 164
Typ Gewindedrehen	Trapezgewinde, Teilprofil, innen	type threading, trapezoidal thread, partial profile, internal	D min. 14 / 16 P = 2.0 - 6.0	... 165

MINICUT

Bohrungsbearbeitung

grooving, boring and profiling

Übersicht

summary

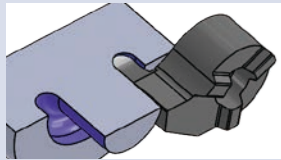

Schneideinsätze Axialstechen

inserts face grooving

Maße dimensions

Seite page

Typ Axialstechen	allgemein	type face grooving	D min. 14 / 18	... 166
Typ Axialstechen	am Zapfen vorbei	type face grooving, in pivots,	D min. 12 / 16	... 167
Typ Axialstechen	Vollradius	type face grooving, full radius	D min. 14 t max. 5	... 168
Typ Axialstechen	am Zapfen vorbei, Vollradius	type face grooving, in pivots, full radius	D min. 12 t max. 5	... 169



Sets Minicut Halter und Schneiden (Rechte Ausführung)

sets Minicut toolholder and inserts (righthand version)

Maße dimensions

Seite page

SET-MC08-LF/R	Auswahl RS008 / RS08	selection RS008 / RS08	D min. 8	... 171
SET-MC11-LF/R	Auswahl RS011 / RS11	selection RS011 / RS11	D min. 11	... 171
SET-MC14-LF/R	Auswahl RS014 / RS14	selection RS014 / RS14	D min. 14	... 172

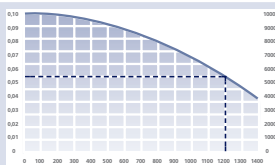

Technische Hinweise

Technical Instructions

Seite page

Schnittwerte und Anzahl der Schnitte beim Gewindedrehen	cutting data and number of passes for threading	... 173
Gewinde schneiden	threading	...174
Hartmetallsorten und Beschichtungen	carbide grades and coatings	... 175
Schnittdaten	cutting data	... 177

MINICUT

Bohrungsbearbeitung

grooving, boring and profiling

Allgemeine Beschreibung

general instruction

Minicut:

Bei dem System Minicut werden die austauschbaren Hartmetallschneiden mittels der bewährten Dreirippenverzahnung stirnseitig verschraubt. Diese gewährleistet beste Wiederholgenauigkeit bei einfachster Handhabung.

Minicut:

In the system Minicut the indexible carbide inserts are frontal screwed by the proven interface. This guarantees best repeat accuracy by most simple handling.

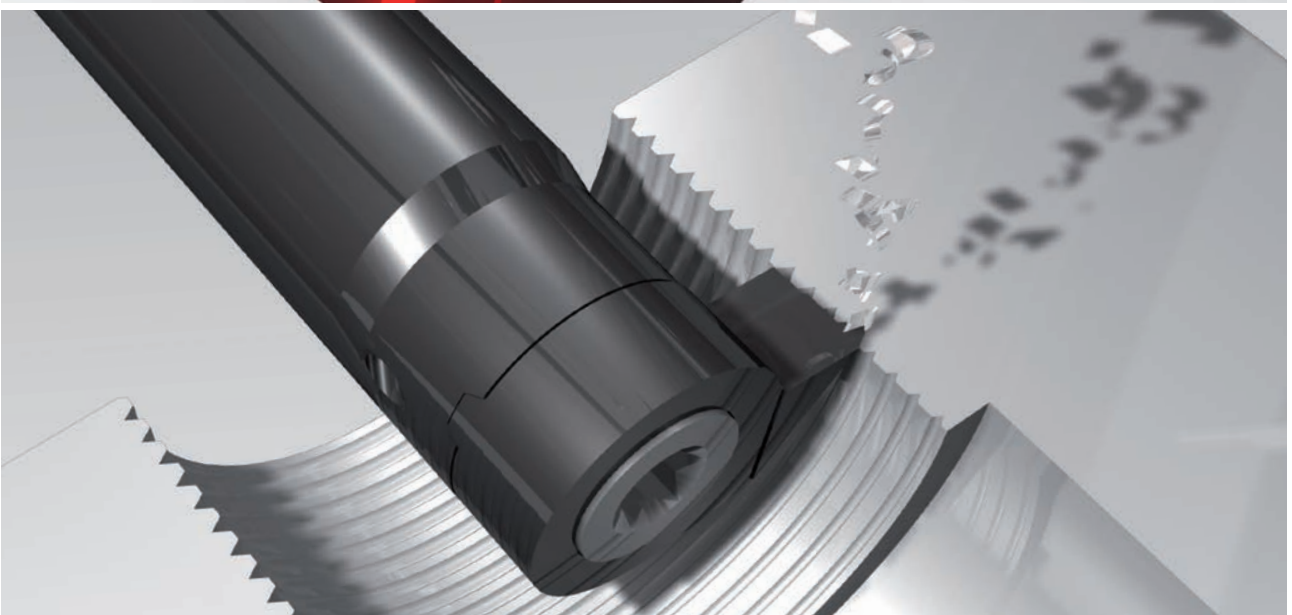
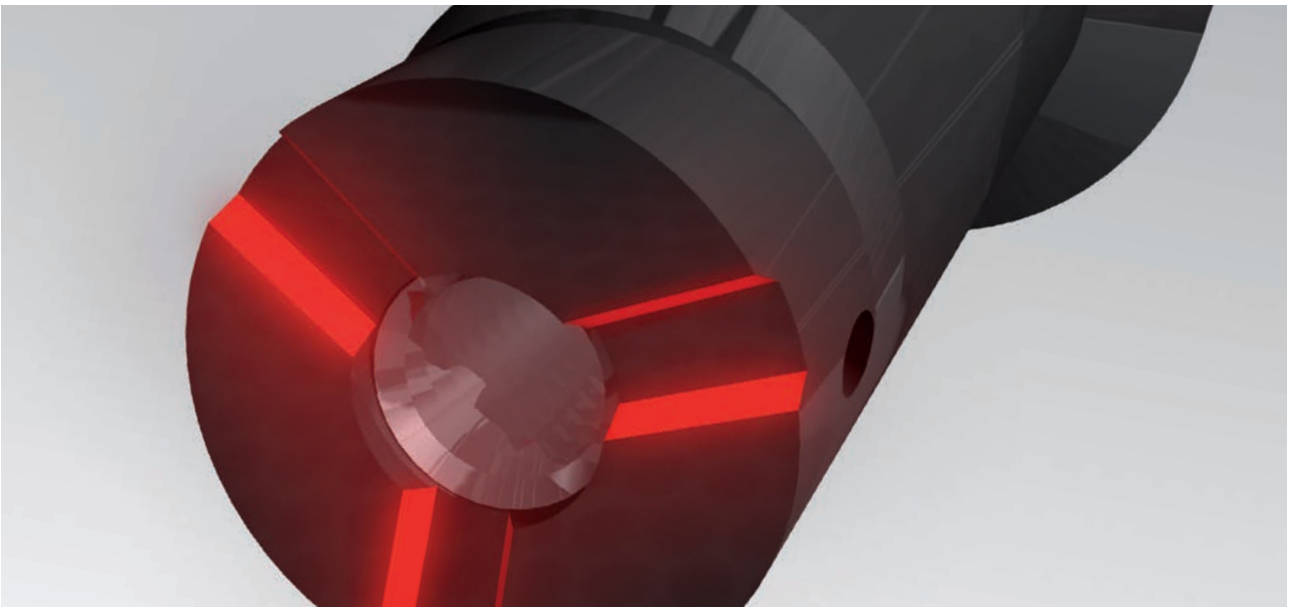

MINICUT

Bohrungsbearbeitung

grooving, boring and profiling

Typ 608 / 609 / 611 / 614

Klemmhalter Stahl

D min. 7.8 mm

toolholder steel

D min. 7.8 mm

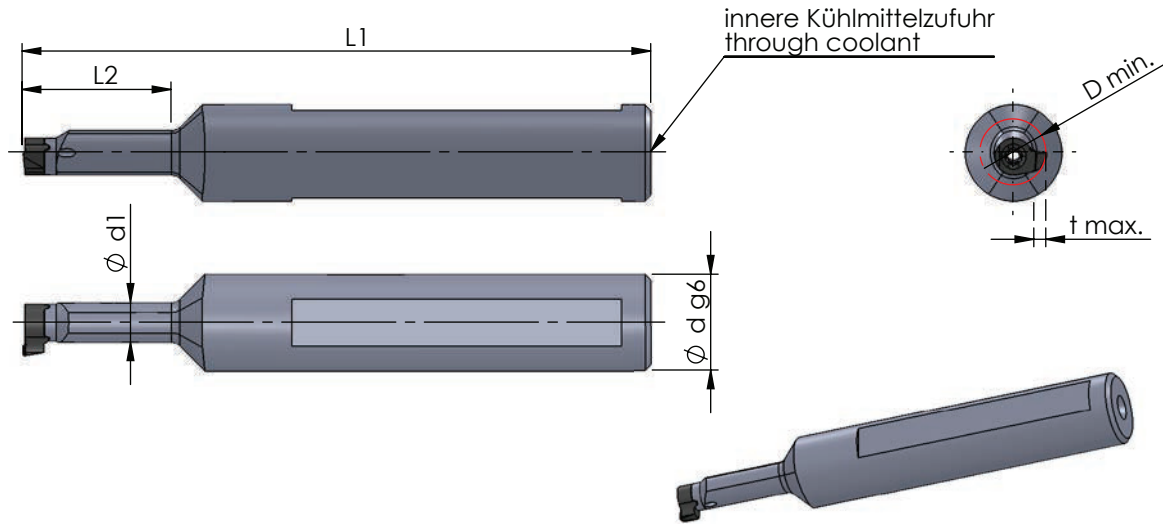

Abmessungen in mm

dimensions in mm

Bestellnummer part number	Ø d g6	Ø d (inch)	Ø d1	L1	L2	Typ: t max. / D min.	Spannschraube screw	Schraubenschlüssel wrench	Anzugs- drehmoment torque	für Schneidplatte use with insert
608.0158.1E.ST	15.875	5/8"	6x7	90	22	R/L S008: 1.0 / Ø8	M2.6-MC	T8	1.0-1.5 Nm	R/L S08 R/L S008
608.0016.1ST	16		6	80	12					
608.0016.1E.ST	16		6x7	90	22					
609.0158.1E.ST	15.875	5/8"	6.6x7.4	105	25	R/L S009: 1.8 / Ø9 R/L S09: 2.8 / Ø10	M2.6-MC	T8	2.0 Nm	R/L S09 R/L S009
609.0016.1ST	16		6.6x7.4	95	14					
609.0016.1E.ST	16		6.6x7.4	105	25					
611.0158.2E.ST	15.875	5/8"	8x9.5	110	29	R/L S011: 2.3 / Ø11	M3.5-MC	T10	2.5-3.0 Nm	R/L S11 R/L S011
611.0016.2ST	16		8	97	16					
611.0016.2E.ST	16		8x9.5	110	29					
614.0127.3ST	12.7	1/2"	9.5x11	100	18	R/L S014: 4.0 / Ø14 R/L S55: 5.5 / Ø16 R/L S65: 6.5 / Ø17	M4-MC	T15	4.0-4.5 Nm	R/L S14 R/L S014 R/L S55 R/L S65
614.0158.3E.ST	15.875	5/8"	9.5x11	120	38					
614.0016.3ST	16		9.5x11	100	18					
614.0016.3E.ST	16		9.5x11	120	38					

Bestellbeispiel:
608.0158.1E.ST

order-example:
608.0158.1E.ST

MINICUT

Bohrungsbearbeitung

grooving, boring and profiling

Typ 616 / 618

Klemmhalter Stahl

D min. 16 mm

toolholder steel

D min. 16 mm

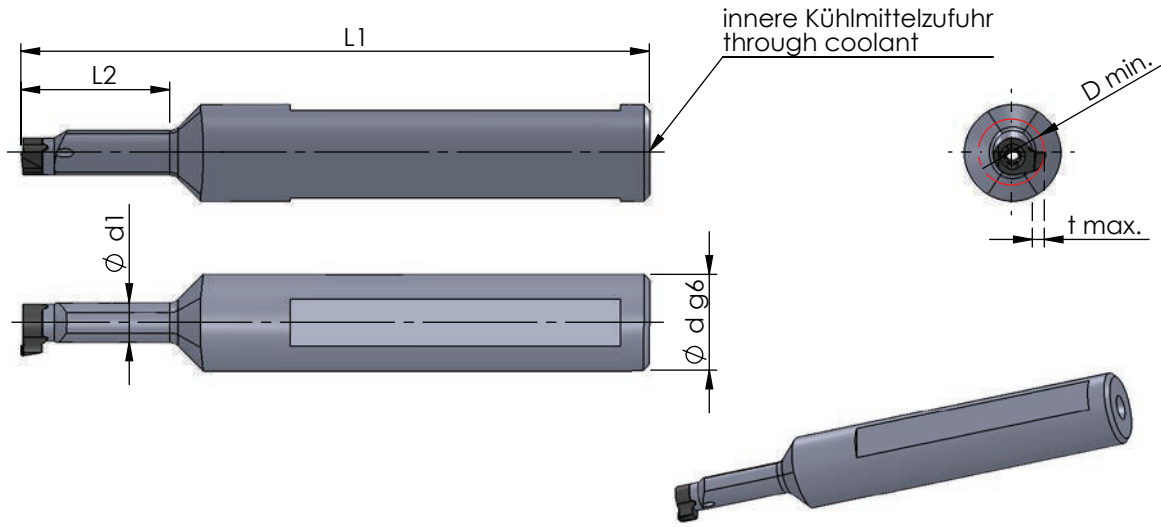

Abmessungen in mm

dimensions in mm

Bestellnummer part number	Ø d g6	Ø d1	L1	L2	Typ: t max. / D min.	Spannschraube screw	Schraubenschlüssel wrench	Anzugs- drehmoment torque	für Schneidplatte use with insert
616.0158.3E.ST	15.875	11x13.5	120	42	R/L S016: 4.3 / Ø16	M5-MC	T20	6.0-6.5 Nm	R/L S16 R/L S016
616.0016.3ST	16	11	100	22					
616.0016.3E.ST	16	11x13.5	120	42	R/L S18: 6 / Ø18 R/L S20: 8 / Ø20				R/L S18 R/L S20
618.0020.3ST	20	11.5	95	25					
618.0020.3E.ST	20	11.5	120	45					

Bestellbeispiel:
616.0158.3E.ST

order-example:
616.0158.3E.ST

MINICUT

Bohrungsbearbeitung

grooving, boring and profiling

Typ 608 / 609

Klemmhalter Hartmetall

D min. 7.8 mm

toolholder carbide

D min. 7.8 mm

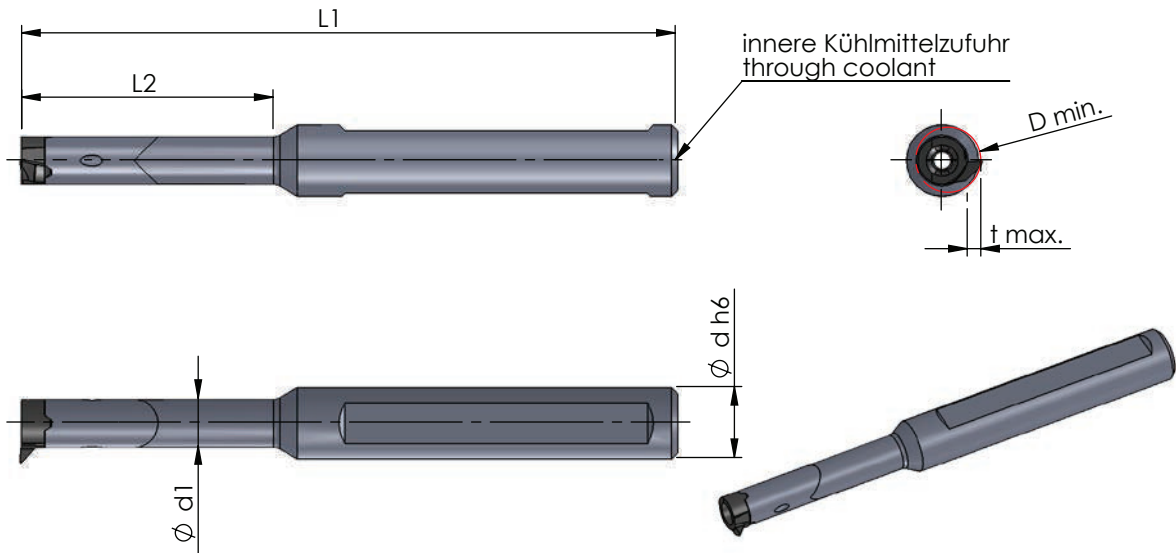

Abmessungen in mm

dimensions in mm

Bestellnummer part number	Ø d h6	Ø d1	L1	L2	Typ: t max. / D min.	Spannschraube screw	Schraubenschlüssel wrench	Anzugs- drehmoment torque	für Schneidplatte use with insert
608.0012.1HM	12	6	80	21	R/L S008: 1.0 / ø8	M2.6-MC	T8	2.0 Nm	R/L S08 R/L S008
608.0012.2HM	12	6	90	30					
608.0012.3HM	12	6	100	42					
608.0012.4HM	12	6	115	50					
608.0127.1HM	12.7	6	80	21					
608.0127.2HM	12.7	6	90	30					
608.0127.3HM	12.7	6	100	42	R/L S009: 1.8 / ø9 R/L S09.10: 2.8 / ø10		2.0 Nm	R/L S09 R/L S009	
609.0012.1HM	12	6.6x7.4	90	22					
609.0012.2HM	12	6.6x7.4	98	30					
609.0012.3HM	12	6.6x7.4	110	42					
609.0012.4HM	12	6.6x7.4	122	56					

Hinweis:
Hartmetall-Klemmhalter mit beschädigter Schneidplattenaufnahme können durch unseren Reparaturservice instand gesetzt werden.

Bestellbeispiel:
608.0012.1HM

note:
carbide-toolholder with damaged seating can be repaired by Dümmel.

order-example:
608.0012.1HM

MINICUT

Bohrungsbearbeitung

grooving, boring and profiling

Typ 611

Klemmhalter Hartmetall

D min. 11 mm

toolholder carbide

D min. 11 mm

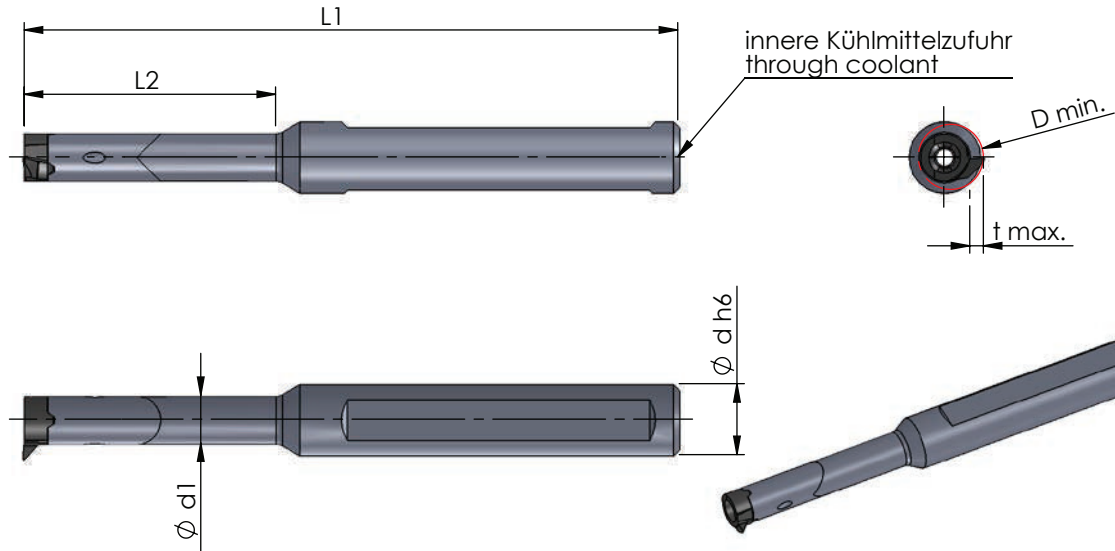

Abmessungen in mm

dimensions in mm

Bestellnummer part number	Ø d h6	Ø d1	L1	L2	Typ: t max. / D min.	Spannschraube screw	Schraubenschlüssel wrench	Anzugs- drehmoment torque	für Schneidplatte use with insert
611.0012.1HM	12	8	95	29	R/L S011: 2.3 / Ø11	M3.5-MC	T10	3.5 Nm	R/L S11 R/L S011
611.0012.2HM	12	8	110	42					
611.0012.3HM	12	8	120	56					
611.0012.4HM	12	8	130	64					
611.0127.1HM	12.7	8	95	29					
611.0127.2HM	12.7	8	110	42					
611.0127.3HM	12.7	8	120	56					

Hinweis:
Hartmetall-Klemmhalter mit beschädigter Schneidplattenaufnahme können durch unseren Reparaturservice in stand gesetzt werden.

Bestellbeispiel:
611.0012.1HM

note:
carbide-toolholder with damaged seating can be repaired by Dümmel.

order-example:
611.0012.1HM

MINICUT

Bohrungsbearbeitung

grooving, boring and profiling

Typ 614

Klemmhalter Hartmetall

toolholder carbide

D min. 14 mm

D min. 14 mm

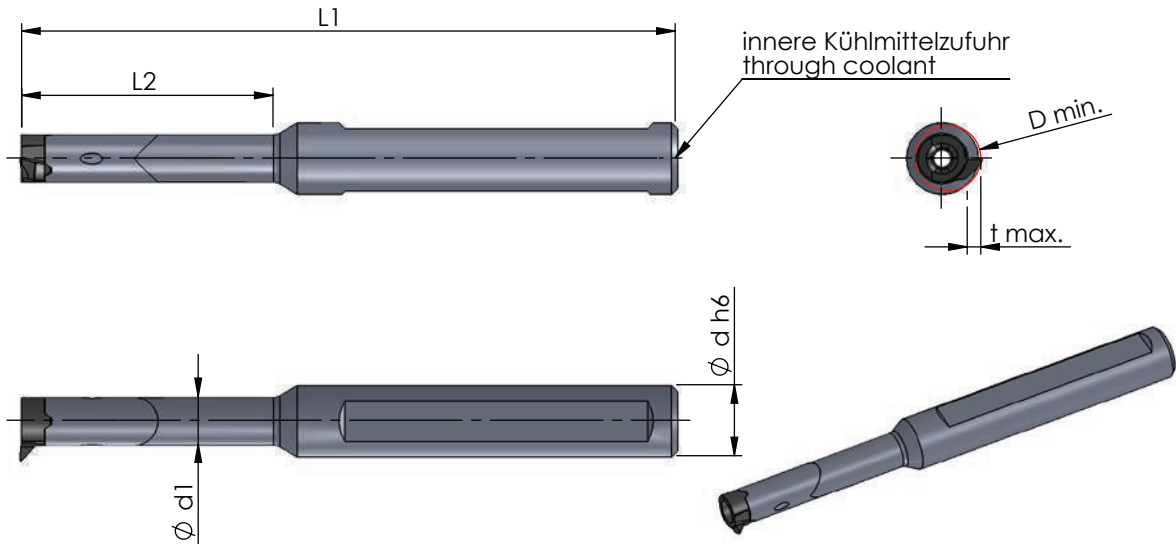

Abmessungen in mm

dimensions in mm

Bestellnummer part number	Ø d h6	Ø d1	L1	L2	Typ: t max. / D min.	Spannschraube screw	Schraubenschlüssel wrench	Anzugs- drehmoment torque	für Schneidplatte use with insert
614.0012.1HM	12	9.5x11	100	34	R/L S014: 4.0 / ø14 R/L S55: 5.5 / ø16 R/L S65: 6.5 / ø17	M4-MC	T15	4.5 Nm	R/L S14 R/L S014 R/L S55 R/L S65
614.0012.2HM	12	9.5x11	110	45					
614.0012.3HM	12	9.5x11	130	64					
614.0127.1HM	12.7	9.5x11	100	34					
614.0127.2HM	12.7	9.5x11	110	45					
614.0127.3HM	12.7	9.5x11	130	64					
614.0158.1HM	15.875	9.5x11	100	34					
614.0158.2HM	15.875	9.5x11	110	45					
614.0158.3HM	15.875	9.5x11	130	64					
614.0016.1HM	16	9.5x11	100	34					
614.0016.2HM	16	9.5x11	110	45					
614.0016.3HM	16	9.5x11	130	64					
614.0016.4HM	16	9.5x11	140	75					

Hinweis:
Hartmetall-Klemmhalter mit beschädigter
Schneidplattenaufnahme können durch unseren
Reparaturservice instand gesetzt werden.

Bestellbeispiel:
614.0012.1HM

note:
carbide-toolholder with damaged seating can be
repaired by Dümmel.

order-example:
614.0012.1HM

MINICUT

Bohrungsbearbeitung

grooving, boring and profiling

Typ 616

Klemmhalter Hartmetall

D min. 16 mm

toolholder carbide

D min. 16 mm

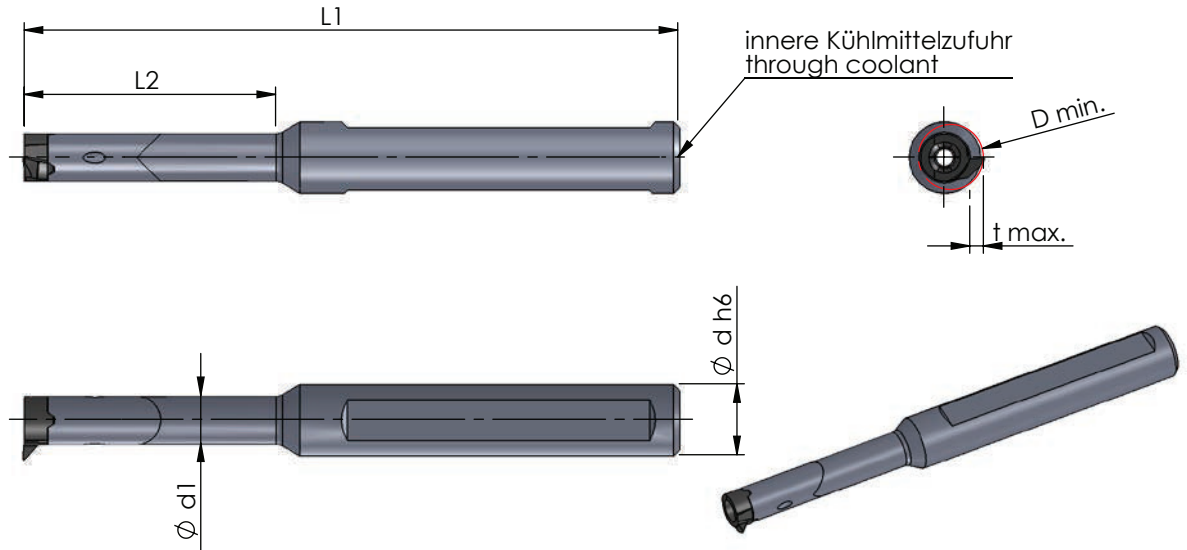

Abmessungen in mm

dimensions in mm

Bestellnummer part number	Ø d h6	Ø d1	L1	L2	Typ: t max. / D min.	Spannschraube screw	Schraubenschlüssel wrench	Anzugs- drehmoment torque	für Schneidplatte use with insert
616.0012.1HM	12	11	130	40	R/L S016: 4.3 / ø16	M5-MC	T20	7.0 Nm	R/L S16 R/L S016
616.0012.2HM	12	11	130	56					
616.0012.3HM	12	11	150	80					
616.0127.1HM	12.7	11	130	40					
616.0127.2HM	12.7	11	130	56					
616.0127.3HM	12.7	11	150	80					
616.0158.1HM	15.875	11	130	40					
616.0158.2HM	15.875	11	130	56					
616.0158.3HM	15.875	11	150	80					
616.0016.1HM	16	11	130	40					
616.0016.2HM	16	11	130	56					
616.0016.3HM	16	11	150	80					

Hinweis:
Hartmetall-Klemmhalter mit beschädigter Schneidplattenaufnahme können durch unseren Reparaturservice in stand gesetzt werden.

Bestellbeispiel:
616.0012.1HM

note:
carbide-toolholder with damaged seating can be repaired by Dümmel.

order-example:
616.0012.1HM

MINICUT

Bohrungsbearbeitung

grooving, boring and profiling

Typ 618

Klemmhalter Hartmetall

D min. 18 mm

toolholder carbide

D min. 18 mm

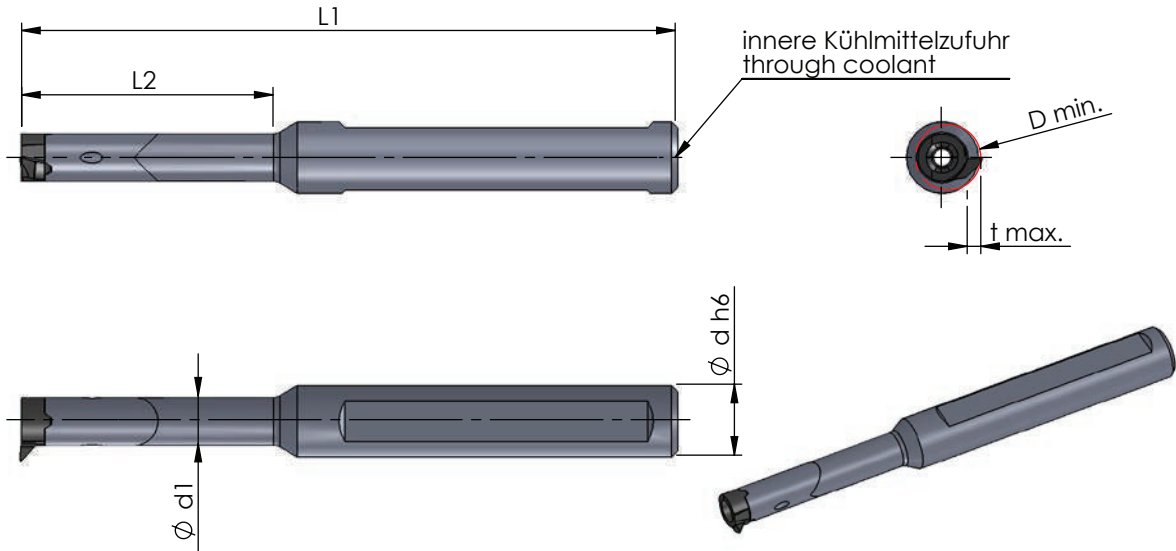

Abmessungen in mm

dimensions in mm

Bestellnummer part number	Ø d h6	Ø d1	L1	L2	Typ: t max. / D min.	Spannschraube screw	Schraubenschlüssel wrench	Anzugs- drehmoment torque	für Schneidplatte use with insert
618.0016.1HM	16	11.5	100	42					
618.0016.2HM	16	11.5	130	60	R/L S18: 6.0 / Ø18				
618.0016.3HM	16	11.5	160	85	R/L S20: 8.0 / Ø20	M5-MC	T20	7.0 Nm	R/L S18 R/L S20
618.0020.3HM	20	11.5	160	85					

Hinweis:
Hartmetall-Klemmhalter mit beschädigter Schneidplattenaufnahme können durch unseren Reparaturservice in stand gesetzt werden.

Bestellbeispiel:
618.0016.1HM

note:
carbide-toolholder with damaged seating can be repaired by Dümmel.

order-example:
618.0016.1HM



MINICUT

Bohrungsbearbeitung

grooving, boring and profiling

Typ V08 / V11

Flexohalter V
Flexible Bearbeitungslänge L1

D min. 8 / 11 mm

Flexo-toolholder V
Flexible working length L1

D min. 8 / 11 mm

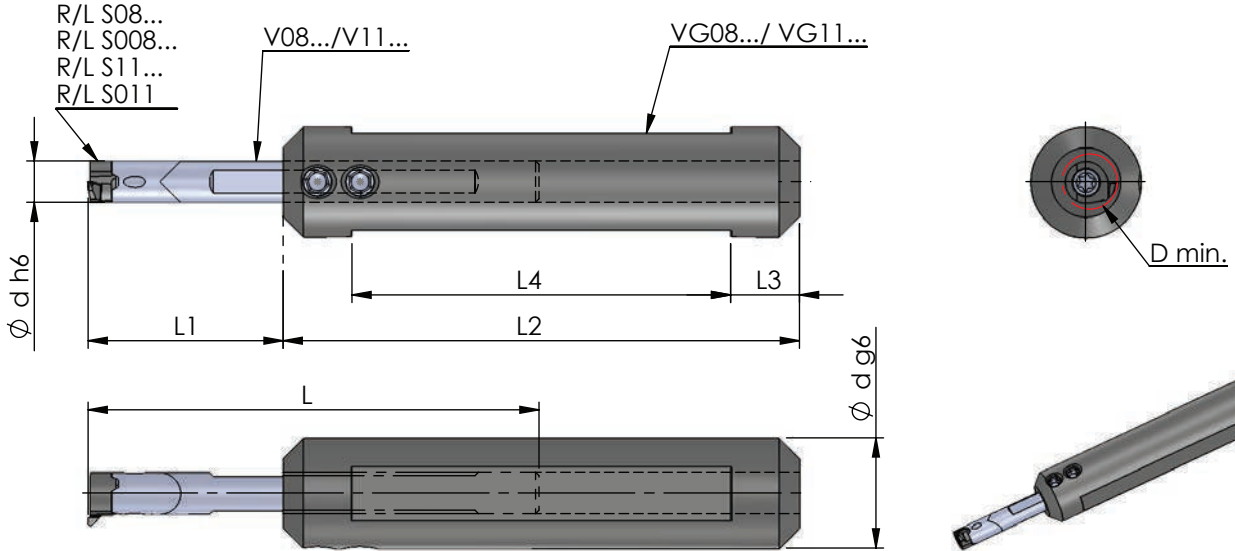

Halter für rechte und linke Schneideinsätze einsetzbar

* V08... ohne IK!

Abmessungen in mm

toolholder for right and left inserts usable

* V08... without IK!

dimensions in mm

Bestellnummer part number	D min.	Ø d h6	L	L1 min.	L1 max.	Spannschraube screw	Schraubenschlüssel wrench	Anzugs- drehmoment torque	für Grundhalter for toolholder basic	für Schneidplatte use with insert
V08.0006.2HM *	8	6	65	18	42	M2.6-MC	T8	1.0-1.5 Nm	VG08	R/L S08 / R/L S008
V08.0006.4HM *	8	6	103	40	80					
V11.0008.2HM	11	8	79	20	55	M3.5-MC	T10	2.5-3.0 Nm	VG11	R/L S11 / R/L S011
V11.0008.4HM	11	8	129	50	105					
Bestellnummer part number	D min.	Ø d g6	L2	L3	L4	Spannschraube screw	Schraubenschlüssel wrench		für Halter for holder	
VG08-16	8	16	75	10	55	G016	111.687		V08	
VG08-20	8	20	75	10	55	G016				
VG11-16	11	16	75	10	55	G012		V11		
VG11-20	11	20	75	10	55	G016				

Hinweis:
Hartmetall-Klemhalter mit beschädigter
Schneidplattenaufnahme können durch unseren
Reparaturservice instand gesetzt werden.

Bestellbeispiel:
V08.0006.2HM

note:
carbide-toolholder with damaged seating can be
repaired by Dümmel.

order-example:
V08.0006.2HM

MINICUT

Bohrungsbearbeitung

grooving, boring and profiling

Typ 614.A / 618.A

Klemmhalter Axialbearbeitung

toolholder face grooving

D min. 12 / 14 / 16 / 18 mm

D min. 12 / 14 / 16 / 18 mm



Abbildung: Halter (R)
Schneideinsatz (R)

Rechter Halter - rechte Platte
Linker Halter - linke Platte

Abmessungen in mm

drawing: toolholder (R)
insert (R)

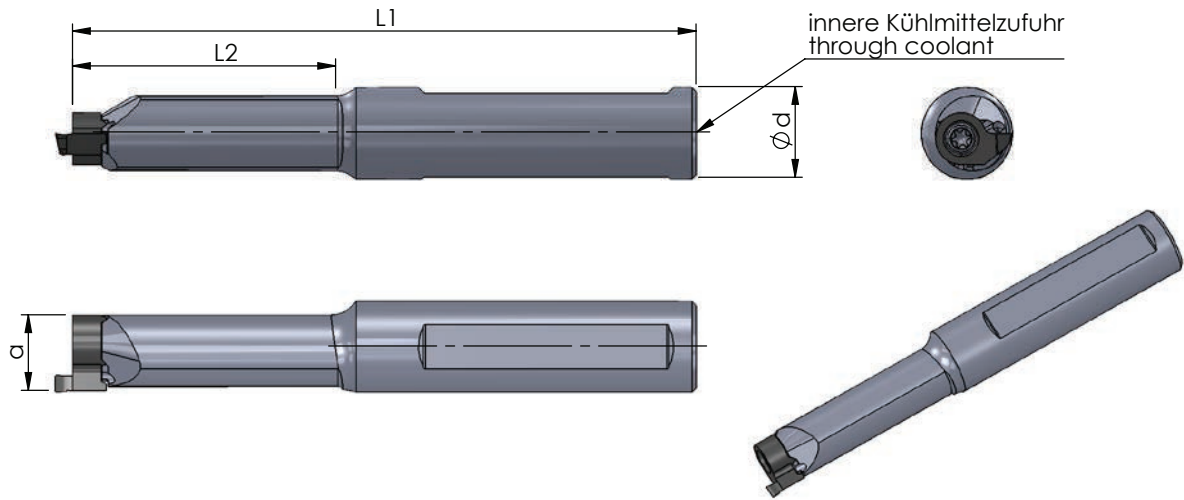
toolholder R - insert R
toolholder L - insert L

dimensions in mm

Bestellnummer part number	Ø d g6	a	L1	L2	Spannschraube screw	Schraubenschlüssel wrench	Anzugs- drehmoment torque	für Schneidplatte use with insert
R/L 614.A016.3ST	16	13.5	90	25	M4-MC	T15	4.0-4.5 Nm	R/L S014
R/L 614.A016.3E.ST	16	13.5	110	45				
Bestellnummer part number	Ø d h6	a	L1	L2	Spannschraube screw	Schraubenschlüssel wrench	Anzugs- drehmoment torque	für Schneidplatte use with insert
R/L 614.A016.3HM	16	13.5	120	60	M4-MC	T15	4.0-4.5 Nm	R/L S014
Bestellnummer part number	Ø d g6	a	L1	L2	Spannschraube screw	Schraubenschlüssel wrench	Anzugs- drehmoment torque	für Schneidplatte use with insert
R/L 618.A016.3ST	16	16.5/17	90	30	M5-MC	T20	6.0-6.5 Nm	R/L S018

Hinweis:
Hartmetall-Klemmhalter mit beschädigter
Schneidplattenaufnahme können durch unseren
Reparaturservice instand gesetzt werden.

Bestellbeispiel:
für rechte Ausführung
R614.A016.3ST

note:
carbide-toolholder with damaged seating can be
repaired by Dümmel.

order-example:
righthand version
R614.A016.3ST

MINICUT

Bohrungsbearbeitung

grooving, boring and profiling

Typ 614.SQ / 618.SQ

Klemhalter Stahl, Quadratschaft, Axialbearbeitung

toolholder steel, square shank, face grooving

D min. 12 / 14 / 16 / 18 mm

D min. 12 / 14 / 16 / 18 mm



Abbildung: Halter (R)
Schneideinsatz (L)
Bitte beachten: Rechter Halter wird mit linker Platte bestückt und umgekehrt.

Abmessungen in mm

drawing: toolholder (R)
insert (L)
Please notice: Use right hand toolholder with left hand insert and vice versa.

dimensions in mm

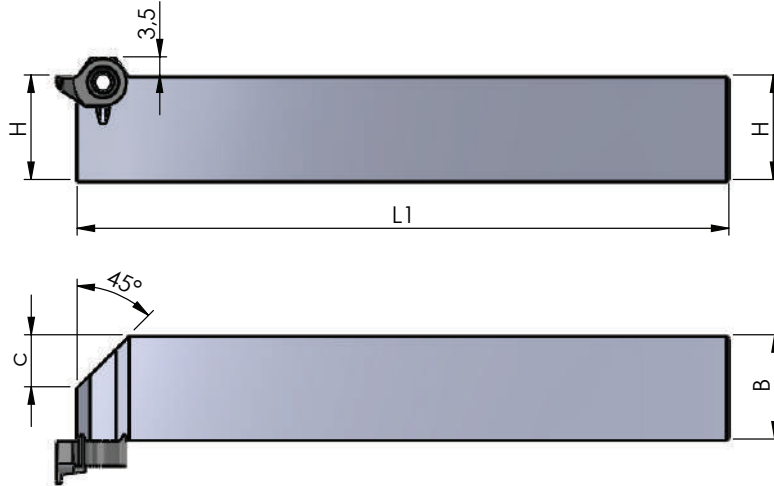
Bestellnummer part number	H	B	L1	c	Spannschraube screw	Schraubenschlüssel wrench	Anzugs- drehmoment torque	für Schneidplatte use with insert
R/L 614.SQ12.ST	12	12	100	2	M4-MC	T15	4.0-4.5 Nm	R/L S014
R/L 614.SQ16.ST	16	16	125	6				
R/L 614.SQ20.ST	20	20	125	10				
R/L 614.SQ25.ST	25	25	150	15				
Bestellnummer part number	H	B	L1	c	Spannschraube screw	Schraubenschlüssel wrench	Anzugs- drehmoment torque	für Schneidplatte use with insert
R/L 618.SQ20.ST	20	20	125	10	M5-MC	T20	6.0-6.5 Nm	R/L S018
R/L 618.SQ25.ST	25	25	150	15				

Bestellbeispiel:
für rechte Ausführung
R614.SQ12.ST

order-example:
righthand version
R614.SQ12.ST

MINICUT

Bohrungsbearbeitung

grooving, boring and profiling

Typ 614.SQ.A / 618.SQ.A

Klemhalter Stahl, Quadratschaft, Axialbearbeitung, abgesetzte Version

toolholder steel, square shank, with offset, face grooving

D min. 12 / 14 / 16 / 18 mm

D min. 12 / 14 / 16 / 18 mm



Abbildung: Halter (R)
Schneideinsatz (L)
Bitte beachten: Rechter Halter wird mit linker Platte bestückt und umgekehrt.

Abmessungen in mm

drawing: toolholder (R)
insert (L)
Please notice: Use right hand toolholder with left hand insert and vice versa.

dimensions in mm

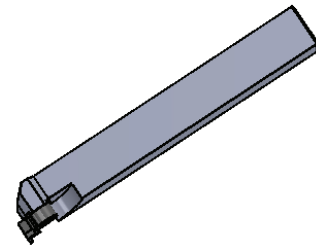
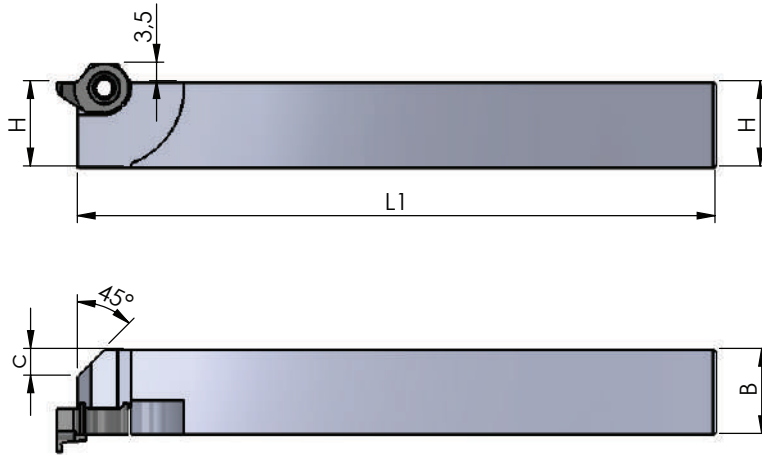
Bestellnummer part number	H	B	L1	c	Spannschraube screw	Schraubenschlüssel wrench	Anzugs- drehmoment torque	für Schneidplatte use with insert
R/L 614.SQ12.ST.A	12	12	100	4	M4-MC	T15	4.0-4.5 Nm	R/L S014
R/L 614.SQ16.ST.A	16	16	120	5				
R/L 614.SQ20.ST.A	20	20	120	5				
R/L 614.SQ25.ST.A	25	25	150	9				
Bestellnummer part number	H	B	L1	c	Spannschraube screw	Schraubenschlüssel wrench	Anzugs- drehmoment torque	für Schneidplatte use with insert
R/L 618.SQ20.ST.A	20	20	120	5	M5-MC	T20	6.0-6.5 Nm	R/L S018
R/L 618.SQ25.ST.A	25	25	150	9				

Bestellbeispiel:
für rechte Ausführung
R614.SQ12.ST.A

order-example:
righthand version
R614.SQ12.ST.A

MINICUT

Bohrungsbearbeitung

grooving, boring and profiling

Impressionen

impressions

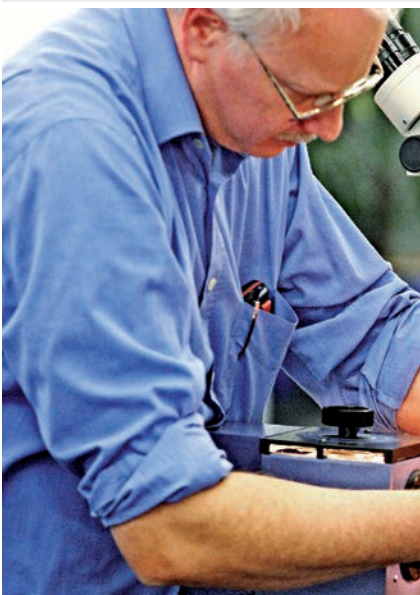
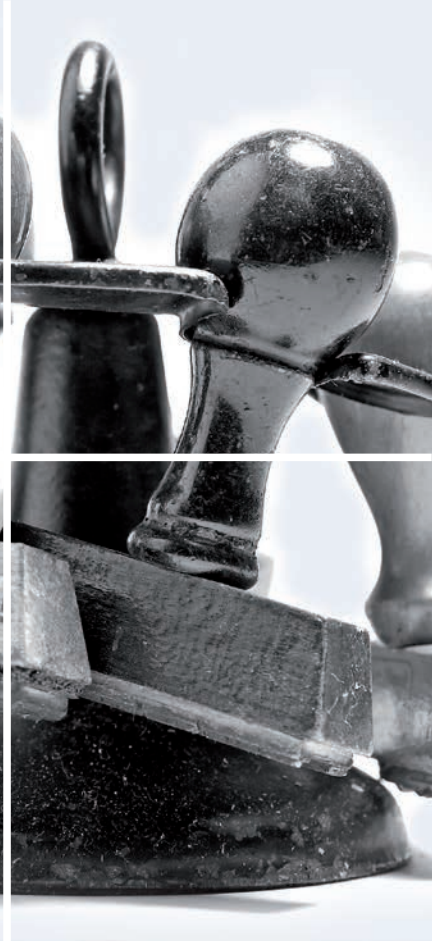

MINICUT

Bohrungsbearbeitung

grooving, boring and profiling

Typ Ausdrehen und Kopieren

allgemein

type boring and profiling,
general

D min. 7.8 - 15.5 mm

D min. 7.8 - 15.5 mm

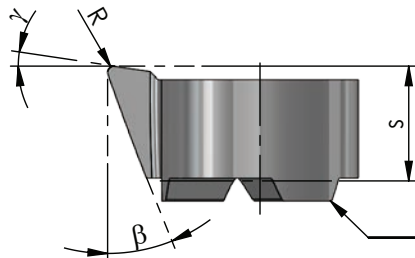
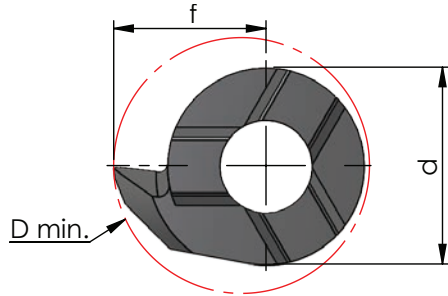

Klemmhalter Stirnseite
toolholder face

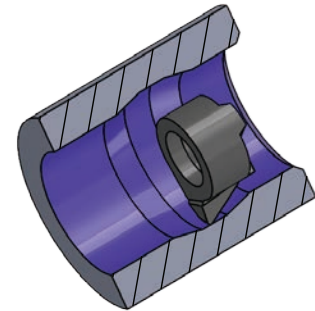

Rechts (R): wie gezeichnet
Links (L): spiegelbildlich

righthand (R): as shown
lefthand version (L): mirror image

Abmessungen in mm

dimensions in mm

Bestellnummer part number	β	γ	R	f	s	d	Ap max.*	D min.					Klemmhalter Typ toolholder type
									K10F	AL41F	P18C	CBN	
R/L S08.1846.005	18°	8°	0.05	4.65	3.5	6	0.6	7.8	●				
R/L S08.1846.02	18°	8°	0.2	4.65	3.5	6	0.6	7.8	●				608
R/L S08.2046.02	20°	20°	0.2	4.65	3.5	6	0.6	7.8	●				
R/L S09.1855.02	18°	8°	0.2	5.50	3.6	6.2	0.8	9.0	●				609
R/L S09.2055.02	20°	20°	0.2	5.50	3.6	6.2	0.8	9.0	●				
R/L S11.1855.02	18°	8°	0.2	5.50	4.2	8	1.0	9.8	●				
R/L S11.1867.02	18°	8°	0.2	6.70	4.2	8	1.0	11.0	●				611
R/L S11.2067.02	20°	20°	0.2	6.70	4.2	8	1.0	11.0	●				
R/L S14.1867.02	18°	8°	0.2	8.70	5.3	9	1.5	13.8	●				614
R/L S14.2087.02	20°	20°	0.2	8.70	5.3	9	1.5	14.0	●				
R/L S16.1897.02	18°	8°	0.2	9.70	5.4	11	1.5	15.5	●				616

*Ap max. = max. Schnitttiefe(werkstoffabhängig)

Weitere HM Sorten können Sie in der Sortenübersicht im Kapitel "Technische Hinweise" und der Preisliste finden.

Bestellbeispiel: für rechte Ausführung und Sorte RS08.1846.02/AL41F

*Ap max. = maximum depth of cut (depending on material)

More carbide grades you can find in the grades summary in the chapter "technical instructions" and in the price list.
order-example: righthand version and grade RS08.1846.02/AL41F

MINICUT

Bohrungsbearbeitung

grooving, boring and profiling

Typ Ausdrehen und Kopieren

von gehärteten Teilen mit CBN

D min. 7.8 - 15.5 mm

type boring and profiling,
of hardened parts with CBN

D min. 7.8 - 15.5 mm

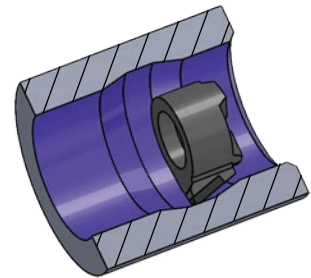
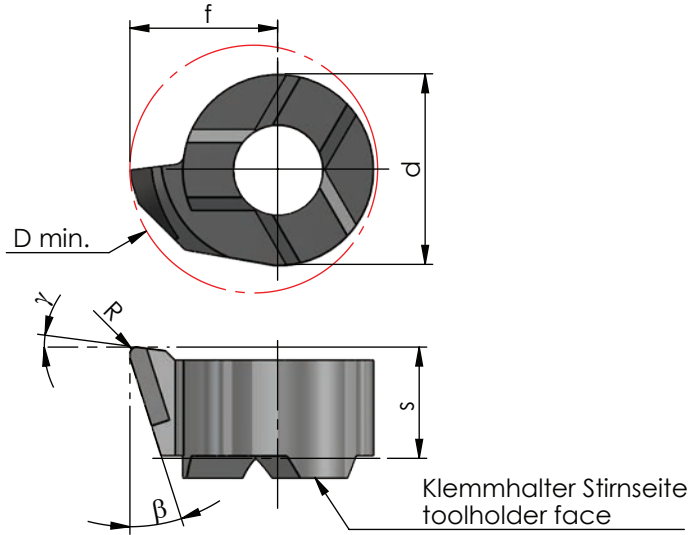

Rechts (R): wie gezeichnet
Links (L): spiegelbildlich

righthand (R): as shown
lefthand version (L): mirror image

Abmessungen in mm

dimensions in mm

Bestellnummer part number	β	γ	R	f	s	d	D min.	Klemmhalter Typ toolholder type				
								K10F	AL41F	CN45F	CBN	
R/L S08.1846.02/CBN	18°	8°	0.2	4.65	3.5	6	7.8				●	608
R/L S11.1867.02/CBN	18°	8°	0.2	6.70	4.1	8	11				●	611
R/L S14.1867.02/CBN	18°	8°	0.2	8.70	5.3	9	14				●	614
R/L S16.1897.02/CBN	18°	8°	0.2	9.70	5.4	11	15.5	●	●	●	●	616

Weitere HM Sorten können Sie in der Sortenübersicht im Kapitel "Technische Hinweise" und der Preisliste finden.

Bestellbeispiel:
für rechte Ausführung und Sorte CBN
RS08.1846.02/CBN

More carbide grades you can find in the grades summary in the chapter "technical instructions" and in the price list.

order-example:
righthand version and grade CBN
RS08.1846.02/CBN

MINICUT

Bohrungsbearbeitung

grooving, boring and profiling

Typ Ausdrehen und Kopieren

allgemein,
Innenfreistriche DIN 509

D min. 7.8 - 20 mm

type boring and profiling,
general, undercuts DIN 509

D min. 7.8 - 20 mm

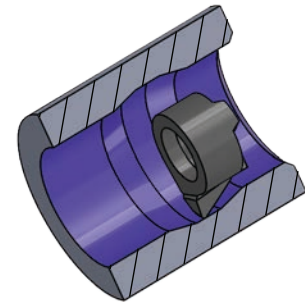
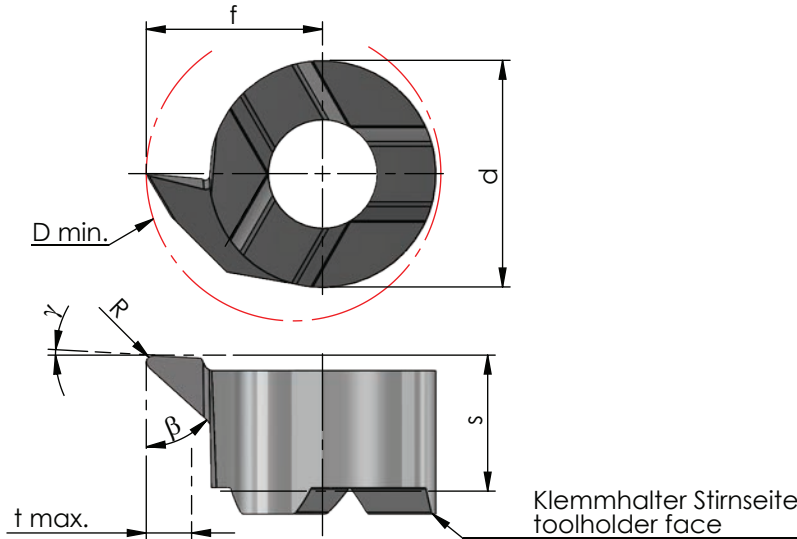

Rechts (R): wie gezeichnet
Links (L): spiegelbildlich

righthand (R): as shown
lefthand version (L): mirror image

Abmessungen in mm

dimensions in mm

Bestellnummer part number	β	γ	R	f	s	d	Ap max.*	t max.	D min.	Klemmhalter Typ toolholder type				
										K10F	AL41F	P18C	CBN	
R/L S08.4746.01	47°	3°	0.1	4.65	3.5	6	0.4	1.2	7.8	●				608
R/L S08.4746.02	47°	3°	0.2	4.65	3.5	6	0.4	1.2	7.8	●				608
R/L S09.4755.02	47°	3°	0.2	5.50	3.6	6.2	0.5	1.5	9.0	●				609
R/L S11.4767.02	47°	3°	0.2	6.70	4.2	8	0.6	2.3	11	●				611
R/L S14.4787.02	47°	3°	0.2	8.70	5.3	9	0.8	4.0	13.7	●				614
R/L S14.4787.04	47°	3°	0.4	8.70	5.3	9	0.8	4.0	13.7	●				614
R/L S16.4710.02	47°	3°	0.2	10.2	5.4	11	1.0	4.3	15.8	●				616
R/L S18.4712.02	47°	3°	0.2	12.0	5.6	11	1.0	6.0	18	●				618
R/L S20.4714.02	47°	3°	0.2	14.0	5.6	11	1.2	8.0	20	●				618
R/L S08.2555.02	30°	5°	0.2	4.65	3.5	6	0.4	1.0	7.8	●	●			608
R/L S11.2755.02	30°	5°	0.2	6.70	4.2	8	0.6	2.3	11	●	●			611
R/L S14.3555.02	30°	5°	0.2	8.70	5.3	9	0.8	4.0	13.7		●			614
R/L S16.4055.02	30°	5°	0.2	10.2	5.4	11	0.8	4.3	15.8		●			616

*Ap max. = max. Schnitttiefe(werkstoffabhängig)

Weitere HM Sorten können Sie in der Sortenübersicht im Kapitel "Technische Hinweise" und der Preisliste finden.

Bestellbeispiel: für rechte Ausführung und Sorte RS08.4746.02/AL41F

*Ap max. = maximum depth of cut (depending on material)

More carbide grades you can find in the grades summary in the chapter "technical instructions" and in the price list.

order-example: righthand version and grade RS08.4746.02/AL41F

MINICUT

Bohrungsbearbeitung

grooving, boring and profiling

Typ Ausdrehen und Kopieren

Ausdrehen mit spezieller Spantreppe

D min. 8 / 9 / 11 mm

type boring and profiling, boring with special chipbreaker

D min. 8 / 9 / 11 mm

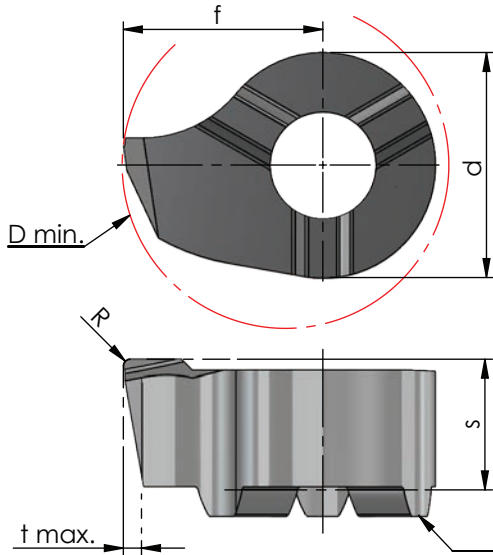

Klemmhalter Stirnseite
toolholder face

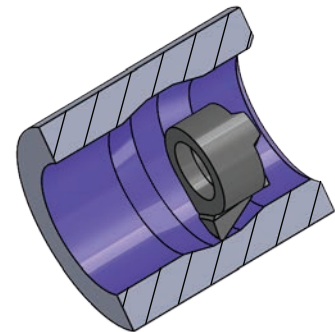

Beispielzeichnung
exemplary application

Rechts (R): wie gezeichnet
Links (L): spiegelbildlich

righthand (R): as shown
lefthand version (L): mirror image

Abmessungen in mm

dimensions in mm

Bestellnummer part number	R	f	s	d	Ap max.*	t max.	D min.	Klemmhalter Typ toolholder type				
								K10F	AL41F	P18C	CBN	
R/L S08.046C.02	0.2	4.65	3.5	6.0	0.4	0.5	8	●				608
R/L S09.055C.02	0.2	5.5	3.6	6.2	0.5	0.5	9		●			609
R/L S11.067C.02	0.2	6.7	4.2	8.0	0.6	0.5	11			●		611

*Ap max. = max. Schnitttiefe(werkstoffabhängig)

Weitere HM Sorten können Sie in der Sortenübersicht im Kapitel "Technische Hinweise" und der Preisliste finden.

Bestellbeispiel: für rechte Ausführung und Sorte RS09.055C.02/AL41F

*Ap max. = maximum depth of cut (depending on material)

More carbide grades you can find in the grades summary in the chapter "technical instructions" and in the price list.
order-example: righthand version and grade RS09.055C.02/AL41F

MINICUT

Bohrungsbearbeitung

grooving, boring and profiling

Typ Ausdrehen und Kopieren

Rückwärtsdrehen

D min. 7.8 - 13.8 mm

type boring and profiling,
backboring

D min. 7.8 - 13.8 mm

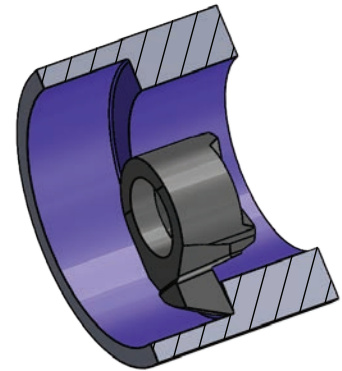
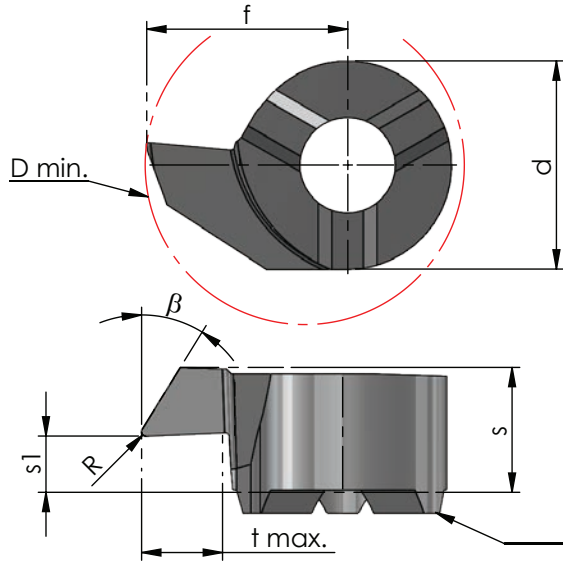

Klemmhalter Stirnseite
toolholder face

Rechts (R): wie gezeichnet
Links (L): spiegelbildlich

righthand (R): as shown
lefthand version (L): mirror image

Abmessungen in mm

dimensions in mm



Bestellnummer part number	β	R	f	s	s1	d	Ap max.*	t max.	D min.	Klemmhalter Typ toolholder type				
										K10F	AL41F	P18C	CBN	
R/L S08.3046.02	30°	0.2	4.65	3.5	1.0	6	0.6	1.3	7.80	●				608
R/L S09.3055.02	30°	0.2	5.5	3.55	1.2	6.2	0.8	1.7	9.00	●				609
R/L S09.3065.02	30°	0.2	6.5	3.55	1.2	6.2	0.8	2.3	10.0	●				609
R/L S11.3067.02	30°	0.2	6.70	4.3	1.6	8	1.0	2.3	11.0	●				611
R/L S14.3087.02	30°	0.2	8.70	5.4	2.4	9	1.5	3.5	13.8	●				614

*Ap max. = max. Schnitttiefe(werkstoffabhängig)

Weitere HM Sorten können Sie in der Sortenübersicht im Kapitel "Technische Hinweise" und der Preisliste finden.

Bestellbeispiel: für rechte Ausführung und Sorte RS08.3046.02/AL41F

*Ap max. = maximum depth of cut (depending on material)

More carbide grades you can find in the grades summary in the chapter "technical instructions" and in the price list.
order-example:righthand version and grade RS08.3046.02/AL41F

MINICUT

Bohrungsbearbeitung

grooving, boring and profiling

Impressionen

impressions

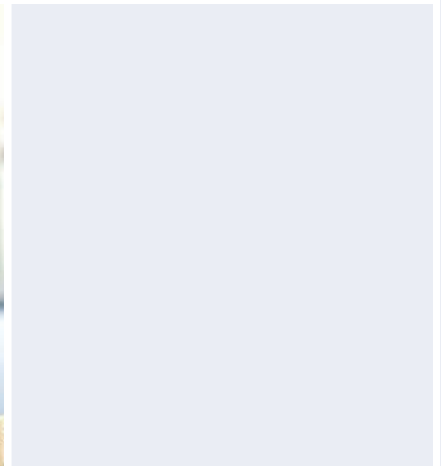
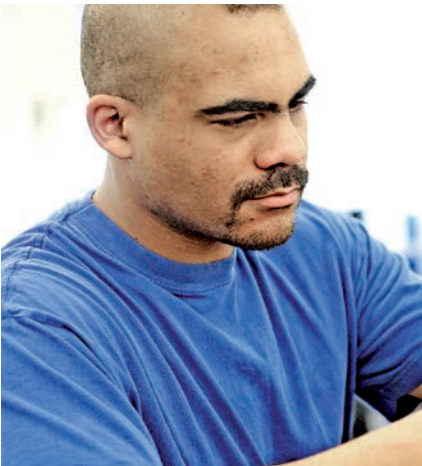
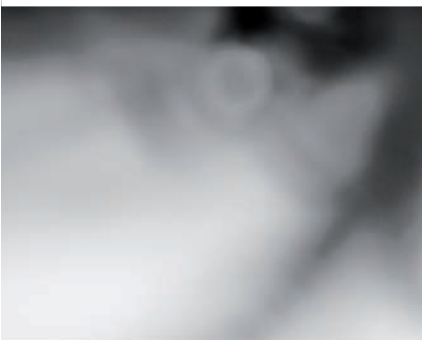
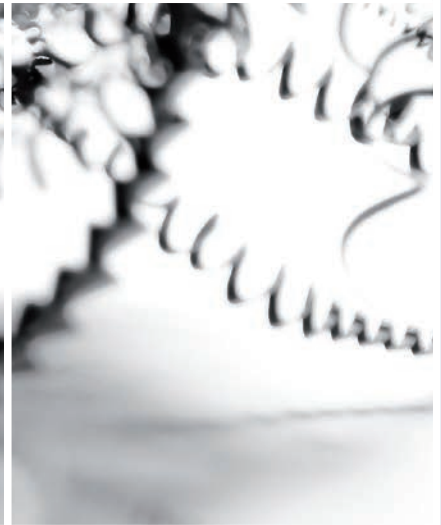
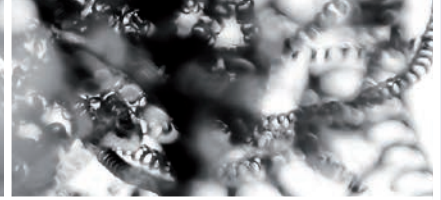

MINICUT

Bohrungsbearbeitung

grooving, boring and profiling

Typ Stechdrehen

für Sicherungsringe DIN 471 / 472
und Stechdrehen allgemein

type grooving,
for circlips DIN 471 / 472
and grooving

D min. 8 mm

D min. 8 mm

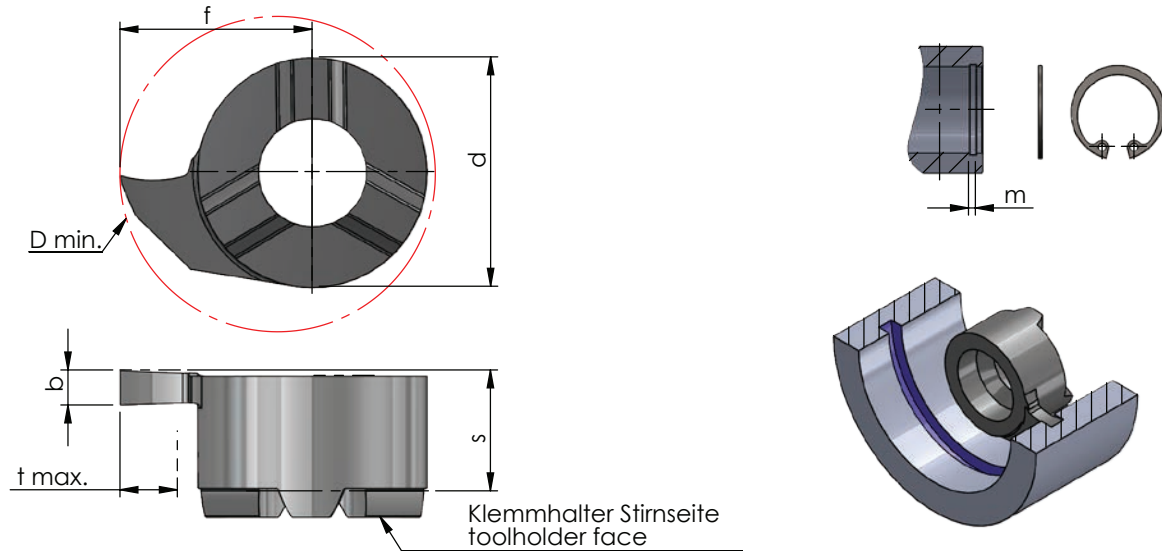

Rechts (R): wie gezeichnet
Links (L): spiegelbildlich

righthand (R): as shown
lefthand version (L): mirror image

Abmessungen in mm

dimensions in mm



Bestellnummer part number	Nut-Maß m groove dim. m DIN 471 / DIN 472	b +0.03	b (inch)	f	s	d	t max.	D min.	Material			Klemmhalter Typ toolholder type
									K10F	AL41F	P18C	
R/L S008.0070	0.7	0.73		4.8	3.3	6	1.0	8		●		608
R/L S008.0079	-	0.79	0.031"	4.8	3.3	6	1.0	8		●		
R/L S008.0080	0.8	0.83		4.8	3.3	6	1.0	8		●		
R/L S008.0090	0.9	0.93		4.8	3.3	6	1.0	8		●		
R/L S008.0099	-	0.99	0.039"	4.8	3.3	6	1.0	8		●		
R/L S008.0100	-	1.00		4.8	3.3	6	1.0	8	●	●		
R/L S008.0110	1.1	1.20		4.8	3.3	6	1.0	8	●	●		
R/L S008.0117	-	1.17	0.046"	4.8	3.3	6	1.0	8		●		
R/L S008.0130	1.3	1.40		4.8	3.3	6	1.0	8		●		
R/L S008.0142	-	1.42	0.056"	4.8	3.3	6	1.0	8		●		
R/L S008.0150	-	1.50		4.8	3.3	6	1.0	8		●		
R/L S008.0157	-	1.57	0.062"	4.8	3.3	6	1.0	8		●		
R/L S008.0160	1.6	1.70		4.8	3.3	6	1.0	8		●		
R/L S008.0198	-	1.98	0.078"	4.8	3.3	6	1.0	8		●		
R/L S008.0200	-	2.00		4.8	3.3	6	1.0	8	●	●		

Weitere HM Sorten können Sie in der Sortenübersicht im Kapitel "Technische Hinweise" und der Preisliste finden.

Bestellbeispiel:
für rechte Ausführung und Sorte
RS008.0070/AL41F

More carbide grades you can find in the grades summary in the chapter "technical instructions" and in the price list.

order-example:
righthand version and grade
RS008.0070/AL41F

MINICUT

Bohrungsbearbeitung

grooving, boring and profiling

Typ Stechdrehen

für Sicherungsringe DIN 471 / 472
und Stechdrehen allgemein

D min. 9 mm

type grooving,
for circlips DIN 471 / 472
and grooving

D min. 9 mm

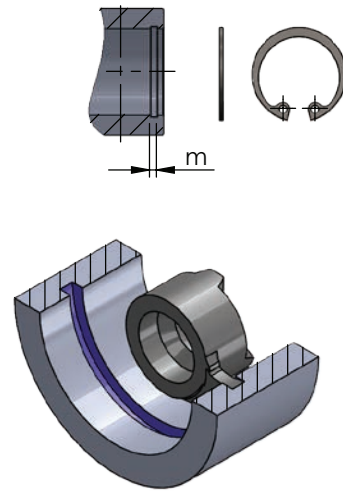
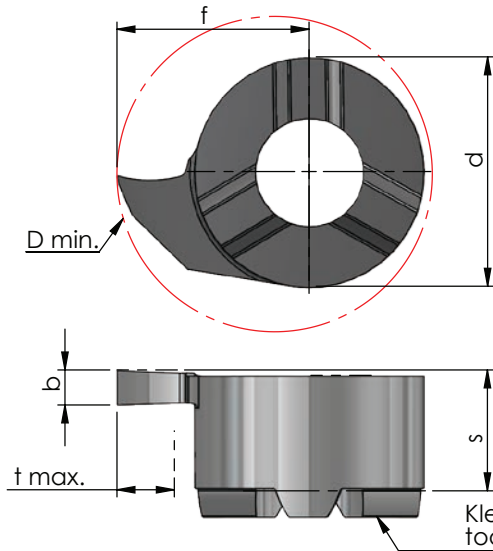

Rechts (R): wie gezeichnet
Links (L): spiegelbildlich

righthand (R): as shown
lefthand version (L): mirror image

Abmessungen in mm

dimensions in mm

Bestellnummer part number	Nut-Maß m groove dim. m DIN 471 / DIN 472	b +0.03	f	s	d	t max.	D min.	K10F	AL41F	P18C	Klemmhalter Typ toolholder type
R/L S009.0070	0.7	0.73	5.5	3.6	6.2	1.2	9	●			609
R/L S009.0080	0.8	0.83	5.5	3.6	6.2	1.3	9	●			
R/L S009.0090	0.9	0.93	5.5	3.6	6.2	1.5	9	●			
R/L S009.0100	-	1.00	5.5	3.6	6.2	1.8	9	●			
R/L S009.0110	1.1	1.20	5.5	3.6	6.2	1.8	9	●			
R/L S009.0130	1.3	1.40	5.5	3.6	6.2	1.8	9	●			
R/L S009.0150	-	1.50	5.5	3.6	6.2	1.8	9	●			
R/L S009.0160	1.6	1.70	5.5	3.6	6.2	1.8	9	●			
R/L S009.0200	-	2.00	5.5	3.6	6.2	1.8	9	●			
R/L S009.0250	-	2.50	5.5	3.6	6.2	1.8	9	●			
R/L S009.0300	-	3.00	5.5	3.6	6.2	1.8	9	●			

Weitere HM Sorten können Sie in der Sortenübersicht im Kapitel "Technische Hinweise" und der Preisliste finden.

Bestellbeispiel:
für rechte Ausführung und Sorte
RS009.0070/AL41F

More carbide grades you can find in the grades summary in the chapter "technical instructions" and in the price list.

order-example:
righthand version and grade
RS009.0070/AL41F

MINICUT

Bohrungsbearbeitung

grooving, boring and profiling

Typ Stechdrehen

für Sicherungsringe DIN 471 / 472
und Stechdrehen allgemein

D min. 11 mm

type grooving,
for circlips DIN 471 / 472
and grooving

D min. 11 mm

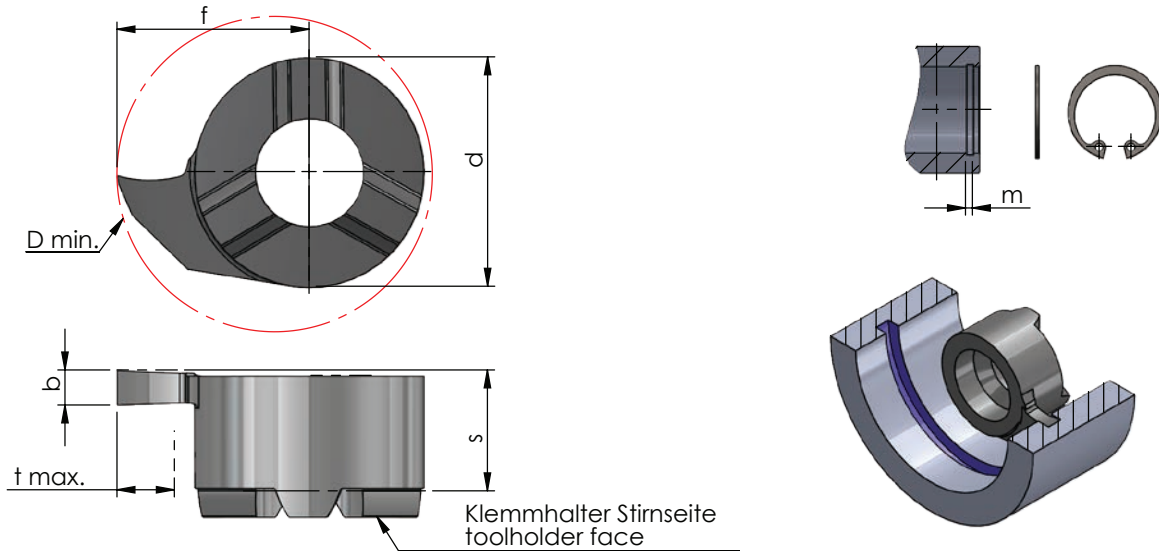

Rechts (R): wie gezeichnet
Links (L): spiegelbildlich

righthand (R): as shown
lefthand version (L): mirror image

Abmessungen in mm

dimensions in mm

Bestellnummer part number	Nut-Maß m groove dim. m DIN 471 / DIN 472	b +0.03	b (inch)	f	s	d	t max.	D min.	Klemmhalter Typ toolholder type			
									K10F	AL41F	P18C	
R/L S011.0070	0.7	0.73		6.7	4.2	8	1.2	11	●			611
R/L S011.0080	0.8	0.83		6.7	4.2	8	1.3	11	●			
R/L S011.0090	0.9	0.93		6.7	4.2	8	1.5	11	●			
R/L S011.0099	-	0.99	0.039"	6.7	4.2	8	1.5	11	●			
R/L S011.0100	-	1.00		6.7	4.2	8	2.3	11	●	●		
R/L S011.0110	1.1	1.20		6.7	4.2	8	2.3	11	●	●		
R/L S011.0117	-	1.17	0.046"	6.7	4.2	8	2.3	11	●			
R/L S011.0130	1.3	1.40		6.7	4.2	8	2.3	11	●	●		
R/L S011.0150	-	1.50		6.7	4.2	8	2.3	11	●	●		
R/L S011.0157	-	1.57	0.062"	6.7	4.2	8	2.3	11	●			
R/L S011.0160	1.6	1.70		6.7	4.2	8	2.3	11	●	●		
R/L S011.0200	-	2.00		6.7	4.2	8	2.3	11	●	●		
R/L S011.0238	-	2.38	0.094"	6.7	4.2	8	2.3	11	●			
R/L S011.0250	-	2.50		6.7	4.2	8	2.3	11	●	●		
R/L S011.0300	-	3.00		6.7	4.2	8	2.3	11	●	●		

Weitere HM Sorten können Sie in der Sortenübersicht im Kapitel "Technische Hinweise" und der Preisliste finden.

Bestellbeispiel:
für rechte Ausführung und Sorte
RS011.0070/AL41F

More carbide grades you can find in the grades summary in the chapter "technical instructions" and in the price list.

order-example:
righthand version and grade
RS011.0070/AL41F

MINICUT

Bohrungsbearbeitung

grooving, boring and profiling

Typ Stechdrehen

für Sicherungsringe DIN 471 / 472
und Stechdrehen allgemein

D min. 14 mm

type grooving,
for circlips DIN 471 / 472
and grooving

D min. 14 mm

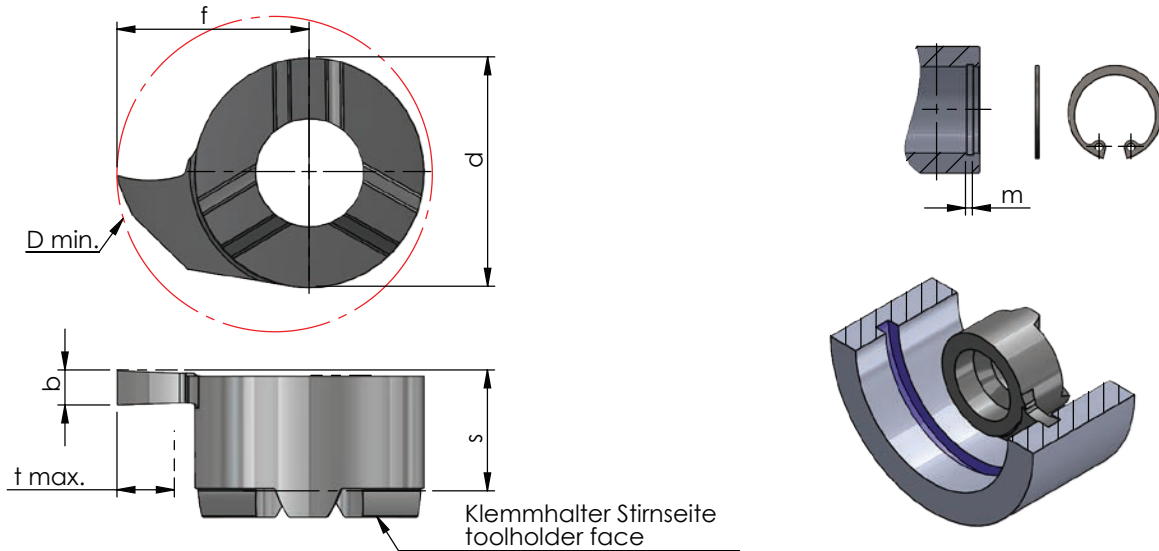

Rechts (R): wie gezeichnet
Links (L): spiegelbildlich

righthand (R): as shown
lefthand version (L): mirror image

Abmessungen in mm

dimensions in mm

neu

Bestellnummer part number	Nut-Maß m groove dim. m DIN 471 / DIN 472	b +0.03	b (inch)	f	s	d	t max.	D min.	K10F	AL41F	P18C	Klemmhalter Typ toolholder type
R/L S014.0070	0.7	0.73		9.0	5.2	9	1.2	14	●			614
R/L S014.0080	0.8	0.83		9.0	5.2	9	1.3	14		●		
R/L S014.0090	0.9	0.93		9.0	5.2	9	1.5	14	●	●		
R/L S014.0100	-	1.00		9.0	5.2	9	4.0	14		●		
R/L S014.0110	1.1	1.20		9.0	5.3	9	4.0	14	●	●		
R/L S014.0117	-	1.17	0.046"	9.0	5.3	9	4.0	14		●		
R/L S014.0130	1.3	1.40		9.0	5.3	9	4.0	14		●		
R/L S014.0150	-	1.50		9.0	5.3	9	4.0	14	●	●		
R/L S014.0157	-	1.57	0.062"	9.0	5.3	9	4.0	14		●		
R/L S014.0160	1.6	1.70		9.0	5.3	9	4.0	14	●	●		
R/L S014.0200	-	2.00		9.0	5.3	9	4.0	14	●	●		
R/L S014.0238	-	2.38	0.094"	9.0	5.3	9	4.0	14		●		
R/L S014.0250	-	2.50		9.0	5.3	9	4.0	14	●	●		
R/L S014.0300	-	3.00		9.0	5.3	9	4.0	14	●	●		

Weitere HM Sorten können Sie in der Sortenübersicht im Kapitel "Technische Hinweise" und der Preisliste finden.

Bestellbeispiel:
für rechte Ausführung und Sorte
RS014.0070/AL41F

More carbide grades you can find in the grades summary in the chapter "technical instructions" and in the price list.

order-example:
righthand version and grade
RS014.0070/AL41F

MINICUT

Bohrungsbearbeitung

grooving, boring and profiling

Typ Stechdrehen

für Sicherungsringe DIN 471 / 472
und Stechdrehen allgemein

D min. 16 mm

type grooving,
for circlips DIN 471 / 472
and grooving

D min. 16 mm

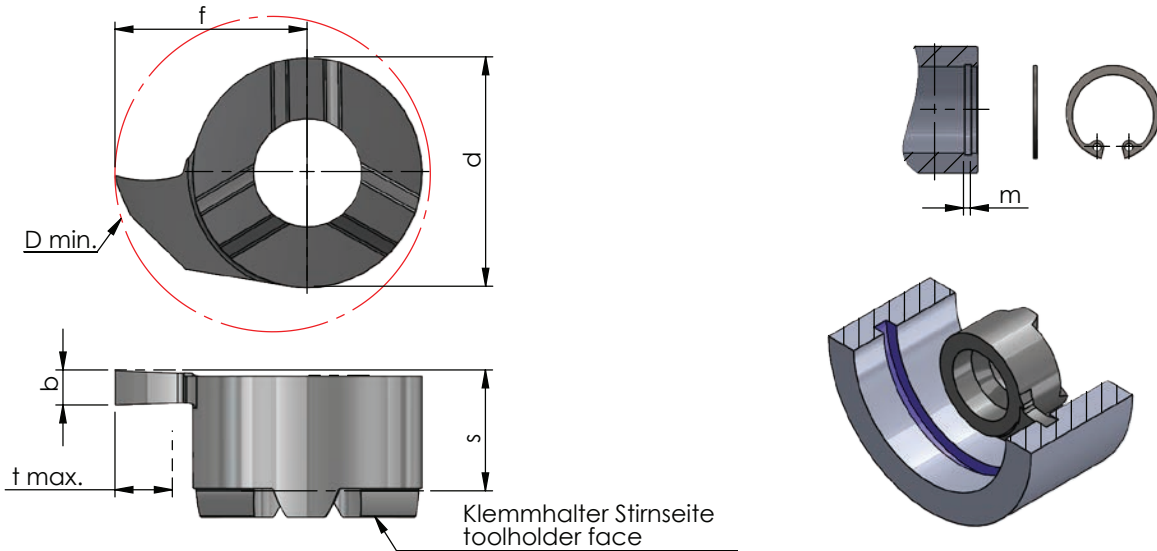

Rechts (R): wie gezeichnet
Links (L): spiegelbildlich

righthand (R): as shown
lefthand version (L): mirror image

Abmessungen in mm

dimensions in mm



Bestellnummer part number	Nut-Maß m groove dim. m DIN 471 / DIN 472	b +0.03	b (inch)	f	s	d	t max.	D min.	Klemmhalter Typ toolholder type		
									K10F	AL41F	P18C
R/L S016.0070	0.7	0.73		10.2	5.2	11	1.2	16		●	
R/L S016.0080	0.8	0.83		10.2	5.2	11	1.3	16		●	
R/L S016.0090	0.9	0.93		10.2	5.2	11	1.5	16		●	
R/L S016.0110	1.1	1.20		10.2	5.4	11	4.3	16	●	●	
R/L S016.0117	-	1.17	0.046"	10.2	5.4	11	4.3	16		●	
R/L S016.0130	1.3	1.40		10.2	5.4	11	4.3	16	●	●	
R/L S016.0150	-	1.50		10.2	5.4	11	4.3	16	●	●	
R/L S016.0157	-	1.57	0.062"	10.2	5.4	11	4.3	16		●	
R/L S016.0160	1.6	1.70		10.2	5.4	11	4.3	16	●	●	
R/L S016.0200	-	2.00		10.2	5.4	11	4.3	16	●	●	
R/L S016.0238	-	2.38	0.094"	10.2	5.4	11	4.3	16		●	
R/L S016.0250	-	2.50		10.2	5.4	11	4.3	16	●	●	
R/L S016.0300	-	3.00		10.2	5.4	11	4.3	16	●	●	
R/L S016.0350	-	3.50		10.2	5.4	11	4.3	16		●	
R/L S016.0400	-	4.00		10.2	5.4	11	4.3	16		●	

616

Weitere HM Sorten können Sie in der Sortenübersicht im Kapitel "Technische Hinweise" und der Preisliste finden.

Bestellbeispiel:
für rechte Ausführung und Sorte
RS016.0070/AL41F

More carbide grades you can find in the grades summary in the chapter "technical instructions" and in the price list.

order-example:
righthand version and grade
RS016.0070/AL41F

MINICUT

Bohrungsbearbeitung

grooving, boring and profiling

Typ Stechdrehen

Stechdrehen allgemein

type grooving,
general use

D min. 18 / 20 mm

D min. 18 / 20 mm

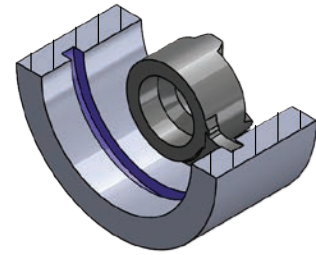
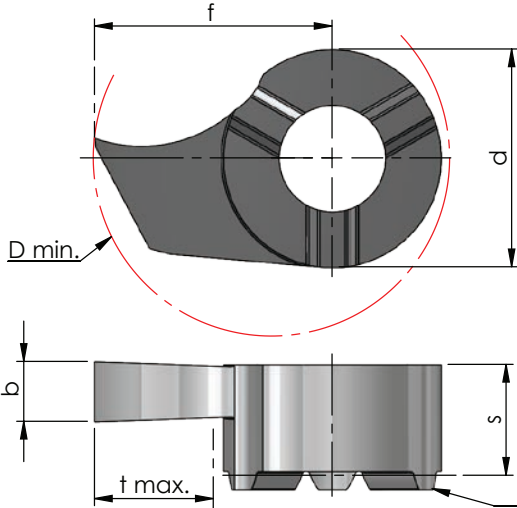

Beispielzeichnung
exemplary application

Rechts (R): wie gezeichnet
Links (L): spiegelbildlich

righthand (R): as shown
lefthand version (L): mirror image

Abmessungen in mm

dimensions in mm

Bestellnummer part number	b +0.03	f	s	d	t max.	D min.				Klemmhalter Typ toolholder type
							K10F	AL41F	P18C	
R/L S18.0150.00	1.5	12	5.6	11	6.0	18	●	●	●	618
R/L S18.0200.00	2.0	12	5.6	11	6.0	18	●	●	●	
R/L S18.0250.00	2.5	12	5.6	11	6.0	18	●	●	●	
R/L S18.0300.00	3.0	12	5.6	11	6.0	18	●	●	●	
R/L S18.0350.00	3.5	12	5.6	11	6.0	18	●	●	●	
R/L S18.0400.00	4.0	12	5.6	11	6.0	18	●	●	●	
R/L S20.0150.00	1.5	14	5.6	11	8.0	20	●	●	●	
R/L S20.0200.00	2.0	14	5.6	11	8.0	20	●	●	●	
R/L S20.0250.00	2.5	14	5.6	11	8.0	20	●	●	●	
R/L S20.0300.00	3.0	14	5.6	11	8.0	20	●	●	●	
R/L S20.0350.00	3.5	14	5.6	11	8.0	20	●	●	●	
R/L S20.0400.00	4.0	14	5.6	11	8.0	20	●	●	●	

Weitere HM Sorten können Sie in der Sortenübersicht im Kapitel "Technische Hinweise" und der Preisliste finden.

Bestellbeispiel:
für rechte Ausführung und Sorte
RS20.0150.00/AL41F

More carbide grades you can find in the grades summary in the chapter "technical instructions" and in the price list.

order-example:
righthand version and grade
RS20.0150.00/AL41F

MINICUT

Bohrungsbearbeitung

grooving, boring and profiling

Typ Stechdrehen

Stechdrehen allgemein,
große Einstechtiefe

type grooving, general use,
maximum depth of groove

D min. 16 / 17 mm

D min. 16 / 17 mm

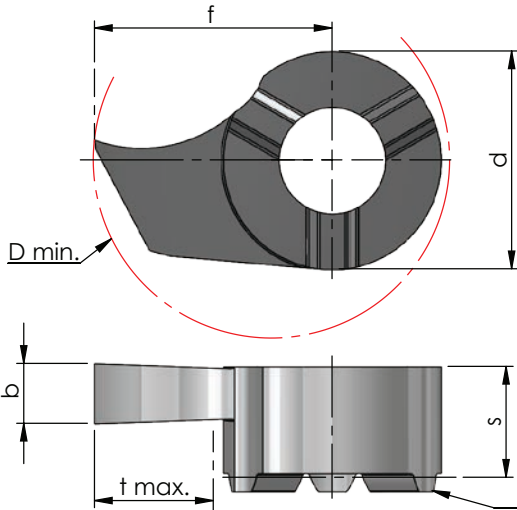

Klemmhalter Stirnseite
toolholder face

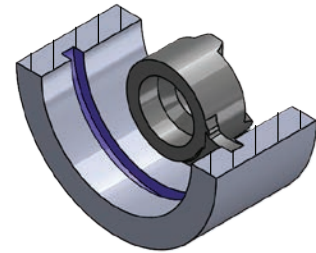

Beispielzeichnung
exemplary application

Rechts (R): wie gezeichnet
Links (L): spiegelbildlich

righthand (R): as shown
lefthand version (L): mirror image

Abmessungen in mm

dimensions in mm

Bestellnummer part number	b +0.03	f	s	d	t max.	D min.				Klemmhalter Typ toolholder type
							K10F	AL41F	P18C	
R/L S55.150.00	1.5	10.5	5.0	9	5.5	16		●		614
R/L S55.200.00	2.0	10.5	5.2	9	5.5	16	●	●		
R/L S55.250.00	2.5	10.5	5.2	9	5.5	16		●		
R/L S55.300.00	3.0	10.5	5.2	9	5.5	16		●		
R/L S65.150.00	1.5	11.5	5.0	9	6.5	17		●		
R/L S65.200.00	2.0	11.5	5.2	9	6.5	17		●		
R/L S65.250.00	2.5	11.5	5.2	9	6.5	17		●		
R/L S65.300.00	3.0	11.5	5.2	9	6.5	17		●		

Weitere HM Sorten können Sie in der Sortenübersicht im Kapitel "Technische Hinweise" und der Preisliste finden.

Bestellbeispiel:
für rechte Ausführung und Sorte
RS55.150.00/AL41F

More carbide grades you can find in the grades summary in the chapter "technical instructions" and in the price list.

order-example:
righthand version and grade
RS55.150.00/AL41F

MINICUT

Bohrungsbearbeitung

grooving, boring and profiling

Typ Stechdrehen

NC-Feindrehen

D min. 8 - 16 mm

type grooving,
NC-profiling

D min. 8 - 16 mm

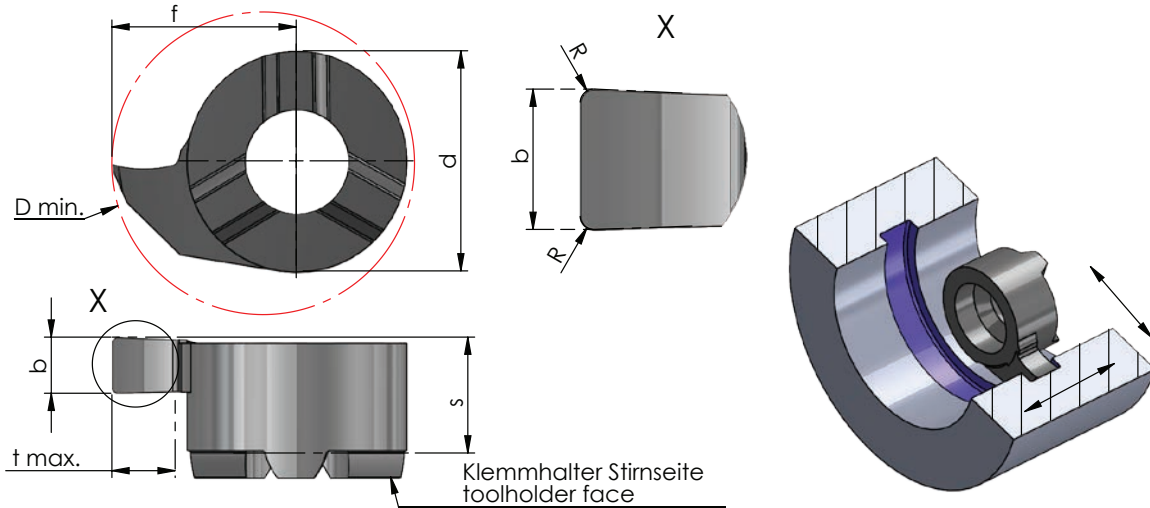

Rechts (R): wie gezeichnet
Links (L): spiegelbildlich

righthand (R): as shown
lefthand version (L): mirror image

Abmessungen in mm

dimensions in mm

Bestellnummer part number	b +0.03	b (inch)	R	f	s	d	Ap max.*	t max.	D min.				Klemhalter Typ toolholder type
										K10F	AL41F	P18C	
R/L S08.079.02	0.79	0.031"	0.2	4.8	3.3	6	0.2	1.0	8		●		608
R/L S08.117.02	1.17	0.046"	0.2	4.8	3.3	6	0.2	1.0	8		●		
R/L S08.150.02	1.50		0.2	4.8	3.3	6	0.2	1.0	8	●	●		
R/L S08.157.02	1.57	0.062"	0.2	4.8	3.3	6	0.2	1.0	8		●		
R/L S08.198.02	1.98	0.078"	0.2	4.8	3.3	6	0.2	1.0	8		●		
R/L S08.200.02	2.00		0.2	4.8	3.3	6	0.2	1.0	8	●	●		
R/L S09.150.02	1.50		0.2	5.5	3.6	6.2	0.2	1.8	9		●		609
R/L S09.200.02	2.00		0.2	5.5	3.6	6.2	0.2	1.8	9		●		
R/L S09.150.02.10	1.50		0.2	6.5	3.6	6.2	0.2	2.8	10		●		
R/L S09.200.02.10	2.00		0.2	6.5	3.6	6.2	0.2	2.8	10		●		
↳ ...													

*Ap max. = max. Schnitttiefe(werkstoffabhängig)

Weitere HM Sorten können Sie in der Sortenübersicht im Kapitel "Technische Hinweise" und der Preisliste finden.

Bestellbeispiel: für rechte Ausführung und Sorte RS08.079.02/AL41F

*Ap max. = maximum depth of cut (depending on material)

More carbide grades you can find in the grades summary in the chapter "technical instructions" and in the price list.

order-example: righthand version and grade RS08.079.02/AL41F

MINICUT

Bohrungsbearbeitung

grooving, boring and profiling

Typ Stechdrehen

NC-Feindrehen

type grooving,
NC-profiling

D min. 8 - 16 mm

D min. 8 - 16 mm

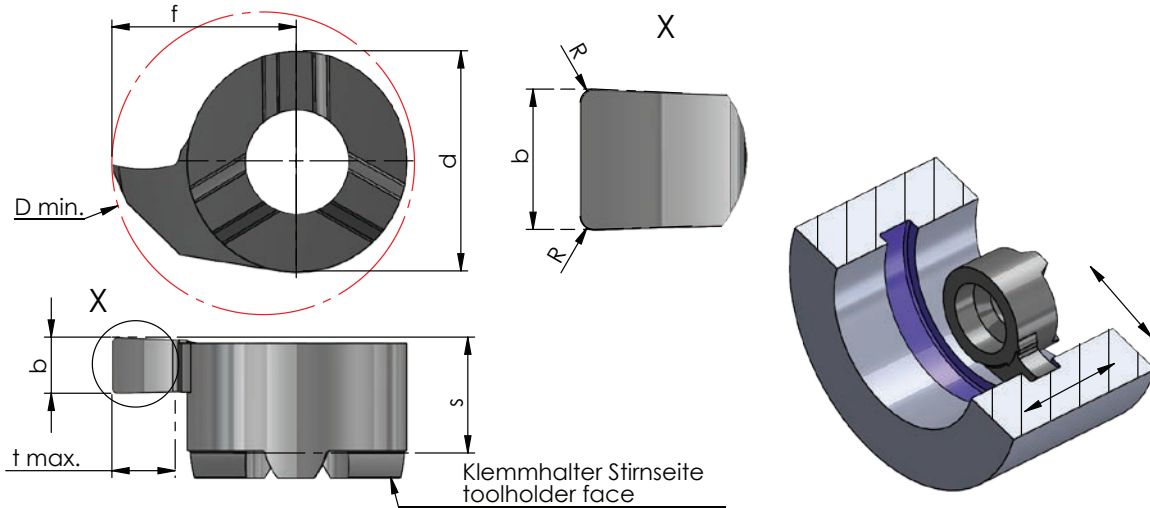

Rechts (R): wie gezeichnet
Links (L): spiegelbildlich

righthand (R): as shown
lefthand version (L): mirror image

Abmessungen in mm

dimensions in mm

neu

Bestellnummer part number	b +0.03	b (inch)	R	f	s	d	Ap max.*	t max.	D min.	Klemmhalter Typ toolholder type		
										K10F	AL41F	P18C
⋮ ↙												
R/L S11.079.02	0.78	0.031"	0.2	6.7	4.2	8	0.2	2.3	11		●	
R/L S11.100.02	1.00		0.2	6.7	4.2	8	0.2	2.3	11		●	
R/L S11.117.02	1.17	0.046"	0.2	6.7	4.2	8	0.2	2.3	11		●	
R/L S11.150.02	1.50		0.2	6.7	4.2	8	0.2	2.3	11	●	●	
R/L S11.157.02	1.57	0.062"	0.2	6.7	4.2	8	0.2	2.3	11		●	
R/L S11.198.02	1.98	0.078"	0.2	6.7	4.2	8	0.2	2.3	11		●	
R/L S11.200.02	2.00		0.2	6.7	4.2	8	0.2	2.3	11	●	●	
R/L S11.238.02	2.38	0.094"	0.2	6.7	4.2	8	0.2	2.3	11		●	
R/L S11.318.02	3.18	0.125"	0.2	6.7	4.2	8	0.2	2.3	11		●	
↳ ...												

*Ap max. = max. Schnitttiefe(werkstoffabhängig)

Weitere HM Sorten können Sie in der Sortenübersicht im Kapitel "Technische Hinweise" und der Preisliste finden.

Bestellbeispiel: für rechte Ausführung und Sorte RS11.079.02/AL41F

*Ap max. = maximum depth of cut (depending on material)

More carbide grades you can find in the grades summary in the chapter "technical instructions" and in the price list.
order-example: righthand version and grade RS11.079.02/AL41F

MINICUT

Bohrungsbearbeitung

grooving, boring and profiling

Typ Stechdrehen

NC-Feindrehen

D min. 8 - 16 mm

type grooving,
NC-profiling

D min. 8 - 16 mm

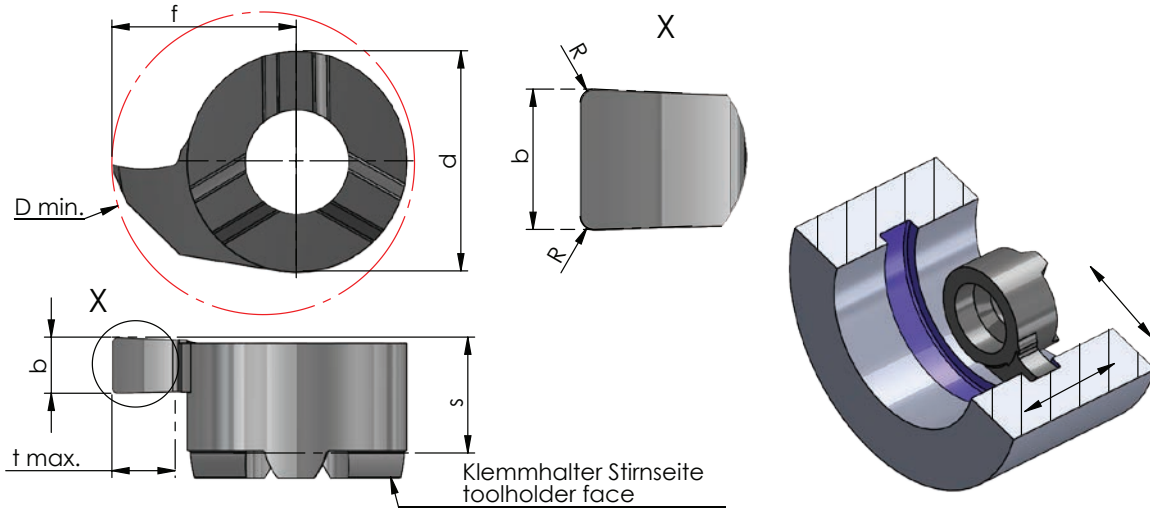

Rechts (R): wie gezeichnet
Links (L): spiegelbildlich

righthand (R): as shown
lefthand version (L): mirror image

Abmessungen in mm

dimensions in mm

Bestellnummer part number	b +0.03	b (inch)	R	f	s	d	Ap max.*	t max.	D min.				Klemmhalter Typ toolholder type
										K10F	AL41F	P18C	
⋮ ↙													
R/L S14.150.02	1.50		0.2	9.0	5.3	9	0.2	4.0	14	●	●		614
R/L S14.157.02	1.57	0.062"	0.2	9.0	5.3	9	0.2	4.0	14		●		
R/L S14.157.04	1.57	0.062"	0.4	9.0	5.3	9	0.2	4.0	14		●		
R/L S14.200.02	2.00		0.2	9.0	5.3	9	0.2	4.0	14	●	●		
R/L S14.238.02	2.38	0.094"	0.2	9.0	5.3	9	0.2	4.0	14		●		
R/L S14.318.02	3.18	0.125"	0.2	9.0	5.3	9	0.2	4.0	14		●		
R/L S16.157.02	1.57	0.062"	0.2	10.2	5.4	11	0.2	4.3	16		●		616
R/L S16.200.02	2.00		0.2	10.2	5.4	11	0.2	4.3	16		●		
R/L S16.318.02	3.18	0.125"	0.2	10.2	5.4	11	0.2	4.3	16		●		

*Ap max. = max. Schnitttiefe(werkstoffabhängig)

Weitere HM Sorten können Sie in der Sortenübersicht im Kapitel "Technische Hinweise" und der Preisliste finden.

Bestellbeispiel: für rechte Ausführung und Sorte RS14.150.02/AL41F

*Ap max. = maximum depth of cut (depending on material)

More carbide grades you can find in the grades summary in the chapter "technical instructions" and in the price list.
order-example: righthand version and grade RS14.150.02/AL41F

MINICUT

Bohrungsbearbeitung

grooving, boring and profiling

Typ Stechdrehen

NC-Feindrehen,
große Einstechtiefe

D min. 16 / 17 mm

type grooving,
NC-profiling,
maximum depth of groove

D min. 16 / 17 mm

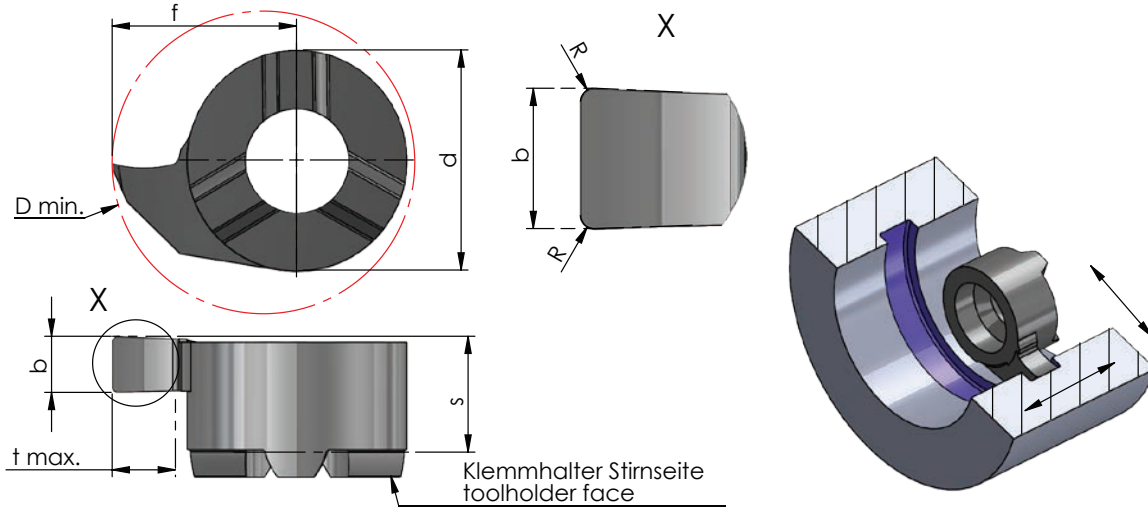

Klemhalter Stirnseite
toolholder face

Rechts (R): wie gezeichnet
Links (L): spiegelbildlich

righthand (R): as shown
lefthand version (L): mirror image

Abmessungen in mm

dimensions in mm

Bestellnummer part number	b +0.03	R	f	s	d	t max.	D min.				Klemhalter Typ toolholder type
								K10F	AL41F	P18C	
R/L S55.150.02	1.5	0.2	10.5	5.2	9	5.5	16		●		614
R/L S55.200.02	2.0	0.2	10.5	5.2	9	5.5	16		●		
R/L S55.250.02	2.5	0.2	10.5	5.2	9	5.5	16		●		
R/L S55.300.02	3.0	0.2	10.5	5.2	9	5.5	16		●		
R/L S65.150.02	1.5	0.2	11.5	5.2	9	6.5	17		●		
R/L S65.200.02	2.0	0.2	11.5	5.2	9	6.5	17		●		
R/L S65.250.02	2.5	0.2	11.5	5.2	9	6.5	17		●		
R/L S65.300.02	3.0	0.2	11.5	5.2	9	6.5	17	●	●		

Weitere HM Sorten können Sie in der Sortenübersicht im Kapitel "Technische Hinweise" und der Preisliste finden.

Bestellbeispiel:
für rechte Ausführung und Sorte
RS55.150.02/AL41F

More carbide grades you can find in the grades summary in the chapter "technical instructions" and in the price list.

order-example:
righthand version and grade
RS55.150.02/AL41F

MINICUT

Bohrungsbearbeitung

grooving, boring and profiling

Typ Stechdrehen

Stechdrehen und Kopieren
Vollradius

type grooving,
grooving and profiling
full radius

D min. 8 - 16 mm
Vollradius R 0.4 - 2.0

D min. 8 - 16 mm
full radius R 0.4 - 2.0

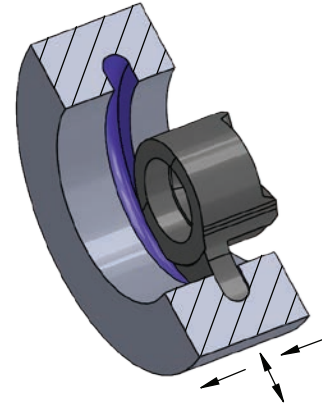
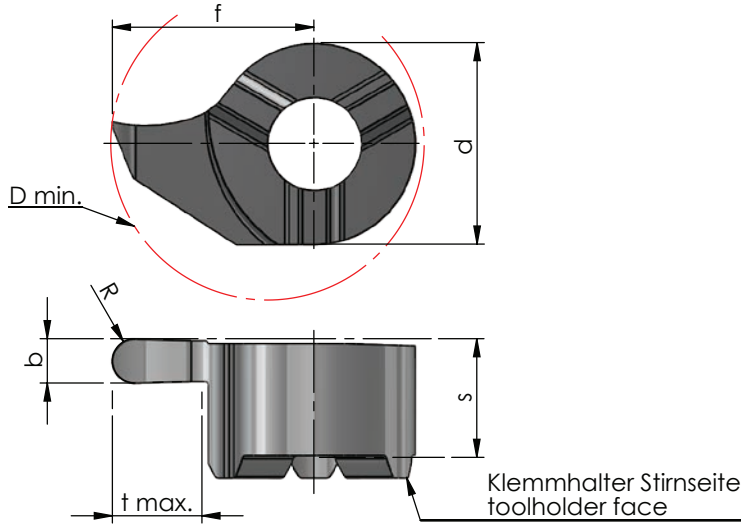

Rechts (R): wie gezeichnet
Links (L): spiegelbildlich

righthand (R): as shown
lefthand version (L): mirror image

Abmessungen in mm

dimensions in mm

Bestellnummer part number	b +0.05	b (inch)	R	f	s	d	t max.	D min.				Klemmhalter Typ toolholder type
									K10F	AL41F	P18C	
R/L S08.008R04	0.80		0.40	4.8	3.3	6.0	1.0	8	●	●		608
R/L S08.012R06	1.20		0.60	4.8	3.3	6.0	1.0	8		●		
R/L S08.U15R08	1.57	0.062"	0.78	4.8	3.3	6.0	1.0	8		●		
R/L S08.018R09	1.80		0.90	4.8	3.3	6.0	1.0	8	●	●		
R/L S08.020R10	2.00		1.00	4.8	3.3	6.0	1.0	8		●		
R/L S09.008R04	0.80		0.40	5.5	3.5	6.2	1.6	9		●		609
R/L S09.012R06	1.20		0.60	5.5	3.5	6.2	1.6	9		●		
R/L S09.018R09	1.80		0.90	5.5	3.5	6.2	1.6	9		●		
R/L S09.020R10	2.00		1.00	5.5	3.5	6.2	1.6	9		●		
↳ ...												

Weitere HM Sorten können Sie in der Sortenübersicht im Kapitel "Technische Hinweise" und der Preisliste finden.

Bestellbeispiel:
für rechte Ausführung und Sorte
RS08.008R04/AL41F

More carbide grades you can find in the grades summary in the chapter "technical instructions" and in the price list.

order-example:
righthand version and grade
RS08.008R04/AL41F

MINICUT

Bohrungsbearbeitung

grooving, boring and profiling

Typ Stechdrehen

Stechdrehen und Kopieren
Vollradius

type grooving,
grooving and profiling
full radius

D min. 8 - 16 mm
Vollradius R 0.4 - 2.0

D min. 8 - 16 mm
full radius R 0.4 - 2.0

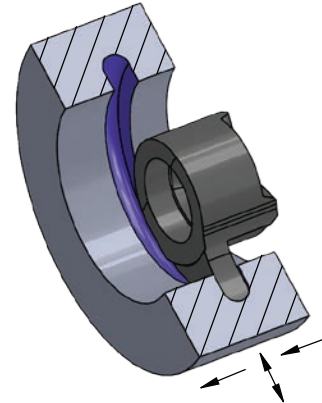
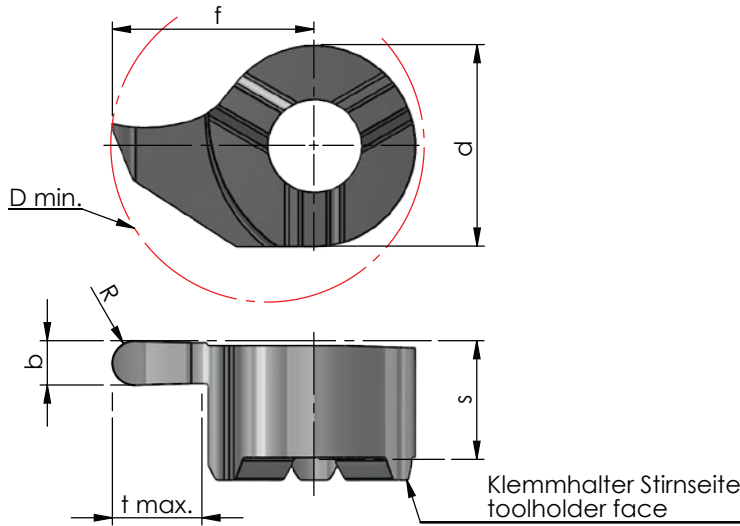

Rechts (R): wie gezeichnet
Links (L): spiegelbildlich

righthand (R): as shown
lefthand version (L): mirror image

Abmessungen in mm

dimensions in mm



Bestellnummer part number	b		R	f	s	d	t max.	D min.	K10F AL41F P18C	Klemmhalter Typ toolholder type
	b +0.05	b (inch)								
⋮ ↓										
R/L S11.008R04	0.80		0.40	6.7	4.2	8	2.3	11	● ●	611
R/L S11.012R06	1.20		0.60	6.7	4.2	8	2.3	11	● ●	
R/L S11.016R08	1.60		0.80	6.7	4.2	8	2.3	11	● ●	
R/L S11.018R09	1.80		0.90	6.7	4.2	8	2.3	11	● ●	
R/L S11.020R10	2.00		1.00	6.7	4.2	8	2.3	11	● ●	
R/L S11.024R12	2.40		1.20	6.7	4.2	8	2.3	11	● ●	
R/L S11.030R15	3.00		1.50	6.7	4.2	8	2.3	11	● ●	
R/L S14.008R04	0.80		0.40	9.0	5.2	9	4.0	14	● ●	614
R/L S14.012R06	1.20		0.60	9.0	5.3	9	4.0	14	● ●	
R/L S14.U15R08	1.57	0.062"	0.78	9.0	5.3	9	4.0	14	● ●	
R/L S14.018R09	1.80		0.90	9.0	5.3	9	4.0	14	● ●	
R/L S14.020R10	2.00		1.00	9.0	5.3	9	4.0	14	● ●	
R/L S14.022R11	2.20		1.10	9.0	5.3	9	4.0	14	● ●	
R/L S14.030R15	3.00		1.50	9.0	5.3	9	4.0	14	● ●	
↳ ...										

Weitere HM Sorten können Sie in der Sortenübersicht im Kapitel "Technische Hinweise" und der Preisliste finden.

Bestellbeispiel:
für rechte Ausführung und Sorte
RS11.008R04/AL41F

More carbide grades you can find in the grades summary in the chapter "technical instructions" and in the price list.

order-example:
righthand version and grade
RS11.008R04/AL41F

MINICUT

Bohrungsbearbeitung

grooving, boring and profiling

Typ Stechdrehen

Stechdrehen und Kopieren
Vollradius

type grooving,
grooving and profiling
full radius

D min. 8 - 16 mm
Vollradius R 0.4 - 2.0

D min. 8 - 16 mm
full radius R 0.4 - 2.0

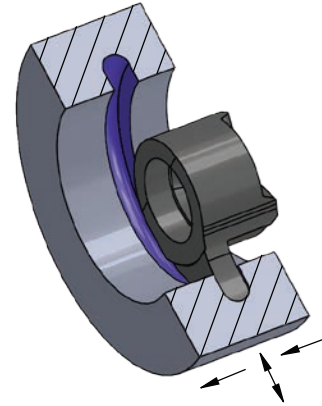
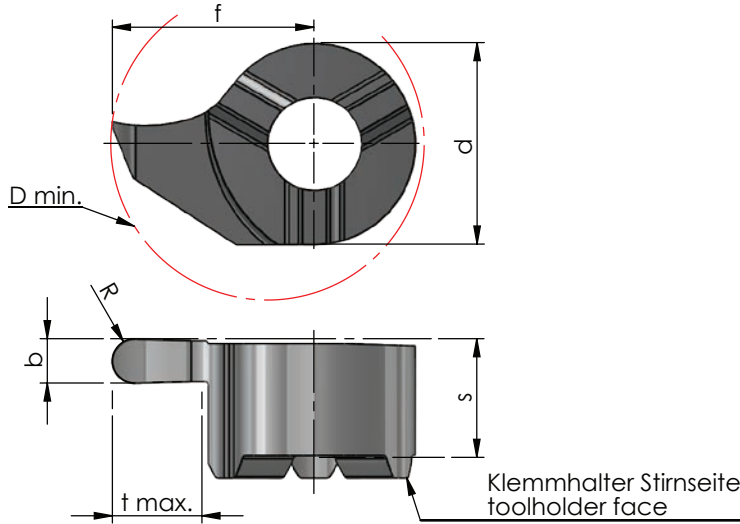

Rechts (R): wie gezeichnet
Links (L): spiegelbildlich

righthand (R): as shown
lefthand version (L): mirror image

Abmessungen in mm

dimensions in mm

Bestellnummer part number	b +0.05	b (inch)	R	f	s	d	t max.	D min.	Klemmhalter Typ toolholder type		
									K10F	AL41F	P18C
neu											
R/L S16.016R08	1.60		0.80	10.2	5.4	11	4.3	16	●		
R/L S16.018R09	1.80		0.90	10.2	5.4	11	4.3	16	●		
R/L S16.020R10	2.00		1.00	10.2	5.4	11	4.3	16	●		
R/L S16.022R11	2.20		1.10	10.2	5.4	11	4.3	16	●		
R/L S16.024R12	2.40		1.20	10.2	5.4	11	4.3	16	●		616
R/L S16.030R15	3.00		1.50	10.2	5.4	11	4.3	16	●		
R/L S16.U31R15	3.18	0.125"	1.57	10.2	5.4	11	4.3	16	●		
R/L S16.032R16	3.20		1.60	10.2	5.4	11	4.3	16	●		
R/L S16.040R20	4.00		2.00	10.2	5.4	11	4.3	16	●		

Weitere HM Sorten können Sie in der Sortenübersicht im Kapitel "Technische Hinweise" und der Preisliste finden.

Bestellbeispiel:
für rechte Ausführung und Sorte
RS14.012R06/AL41F

More carbide grades you can find in the grades summary in the chapter "technical instructions" and in the price list.

order-example:
righthand version and grade
RS14.012R06/AL41F

MINICUT

Bohrungsbearbeitung

grooving, boring and profiling

Typ Stechdrehen

Ausdrehen und Fasen

type grooving,
boring and chamfering

D min. 8 - 14 mm

D min. 8 - 14 mm

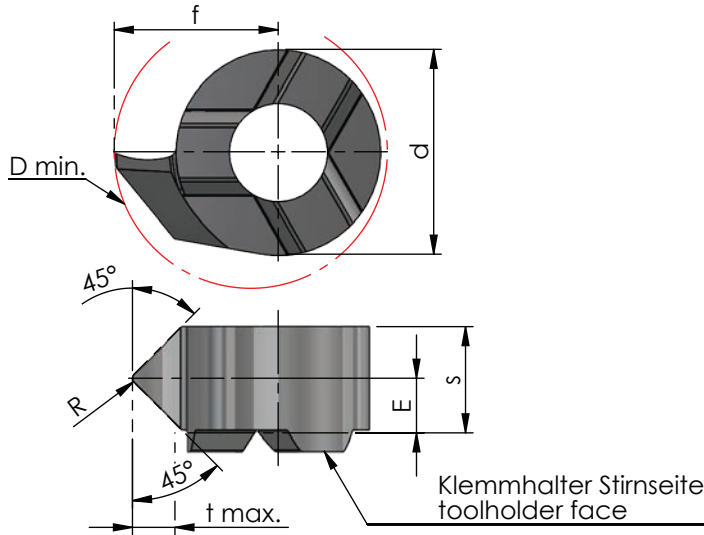

Rechts (R): wie gezeichnet
Links (L): spiegelbildlich

righthand (R): as shown
lefthand version (L): mirror image

Abmessungen in mm

dimensions in mm

Bestellnummer part number	R	f	s	E	d	Ap max.*	t max.	D min.	Klemmhalter Typ toolholder type				
									K10F	AL41F	P18C	CBN	
R/L S08.4545.02	0.2	4.8	3.70	1.60	6.0	0.6	1.4	8	●				608
R/L S09.4545.02	0.2	5.5	3.55	1.80	6.2	0.8	1.3	9		●			609
R/L S11.4545.02	0.2	6.7	4.30	2.20	8.0	1.0	1.5	11	●	●			611
R/L S14.4545.02	0.2	9.0	5.35	2.70	9.0	1.2	1.5	14	●	●			614

*Ap max. = max. Schnitttiefe(werkstoffabhängig)

Weitere HM Sorten können Sie in der Sortenübersicht im Kapitel "Technische Hinweise" und der Preisliste finden.

Bestellbeispiel: für rechte Ausführung und Sorte RS08.4545.02/AL41F

*Ap max. = maximum depth of cut (depending on material)

More carbide grades you can find in the grades summary in the chapter "technical instructions" and in the price list.
order-example: righthand version and grade RS08.4545.02/AL41F

MINICUT

Bohrungsbearbeitung

grooving, boring and profiling

Typ Stechdrehen

Vorstechen und Fasen

D min. 8 - 16 mm

type grooving,
pregrooving and chamfering

D min. 8 - 16 mm

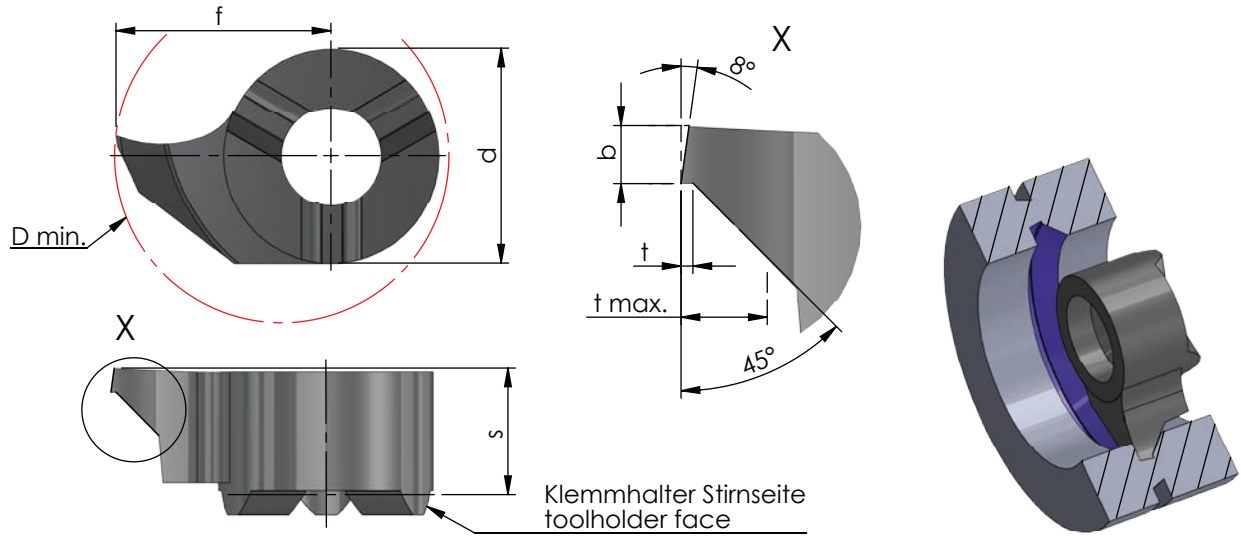

Klemmhalter Stirnseite
toolholder face

Rechts (R): wie gezeichnet
Links (L): spiegelbildlich

righthand (R): as shown
lefthand version (L): mirror image

Abmessungen in mm

dimensions in mm

Bestellnummer part number	b	t	f	s	d	t max.	D min.	Klemmhalter Typ toolholder type			
								K10F	AL41F	P18C	
R/L S08.0810.45	1	0.2	4.8	3.3	6.0	1.0	8	●			608
R/L S09.0810.45	1	0.2	5.5	3.6	6.2	1.5	9	●			609
R/L S11.0810.45	1	0.2	6.7	4.2	8.0	1.5	11	●			611
R/L S14.0815.45	1	0.2	9.0	5.3	9.0	1.5	14	●			614
R/L S16.0815.45	1	0.2	10.2	5.4	11.0	1.5	16	●			616

Weitere HM Sorten können Sie in der Sortenübersicht im Kapitel "Technische Hinweise" und der Preisliste finden.

Bestellbeispiel:
für rechte Ausführung und Sorte
RS14.0815.45/AL41F

More carbide grades you can find in the grades summary in the chapter "technical instructions" and in the price list.

order-example:
righthand version and grade
RS14.0815.45/AL41F

MINICUT

Bohrungsbearbeitung

grooving, boring and profiling

Typ Gewindedrehen

metrisches ISO-Gewinde,
Teilprofil, innen

type threading,
metric ISO-thread,
partial profile, internal

D min. 8 / 9 mm
Steigung P = 0.5 - 3.5

D min. 8 / 9 mm
pitch P = 0.5 - 3.5

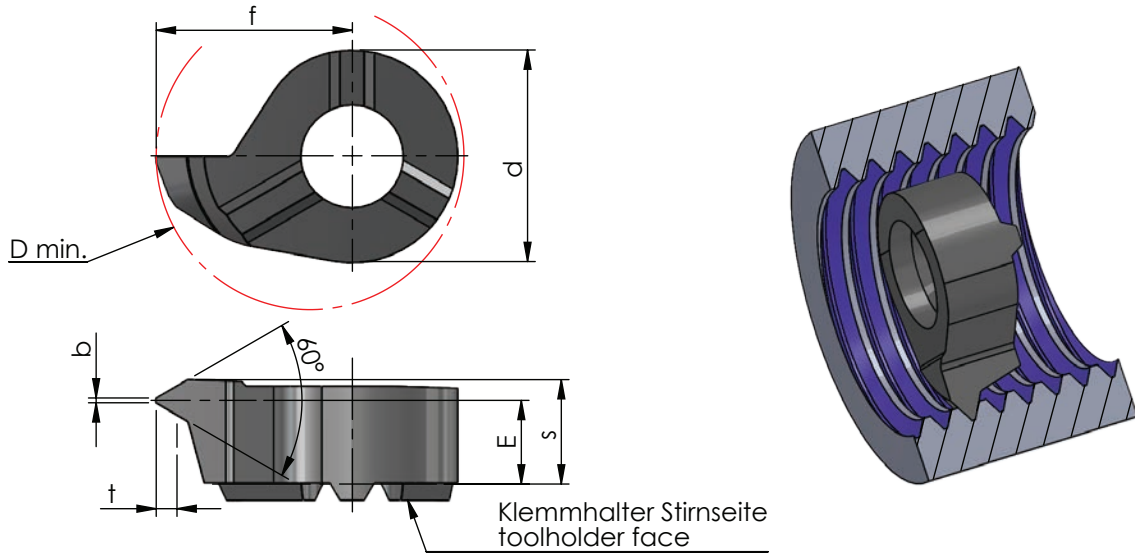

Rechts (R): wie gezeichnet
Links (L): spiegelbildlich

righthand (R): as shown
lefthand version (L): mirror image

Abmessungen in mm

dimensions in mm



Bestellnummer part number	Steigung P pitch P	t	b	f	s	d	E	D min.				Klemmhalter Typ toolholder type
									K10F	AL41F	P18C	
R/L S08.0205.01	0.5-0.75	0.43	0.06	4.8	3.40	6.0	2.95	8		●		608
R/L S08.0510.01	1.0-1.25	0.70	0.12	4.8	3.40	6.0	2.70	8	●	●		
R/L S08.0815.01	1.5-1.75	0.95	0.18	4.8	3.40	6.0	2.50	8	●	●		
R/L S09.0205.01	0.5-0.75	0.27	0.06	5.5	3.55	6.2	3.20	9		●		609
R/L S09.0510.01	1.0-1.25	0.54	0.12	5.5	3.55	6.2	3.00	9		●		
R/L S09.0815.01	1.5-1.75	0.81	0.18	5.5	3.55	6.2	2.80	9		●		
R/L S09.0917.01	1.75-2.0	0.95	0.20	5.5	3.55	6.2	2.60	9		●		
R/L S09.1020.01	2.0-2.5	1.08	0.25	5.5	3.55	6.2	2.50	9		●		
R/L S09.1325.01	2.5-3.0	1.35	0.31	5.5	3.55	6.2	2.10	9		●		
R/L S09.1630.01	3.0-3.5	1.62	0.37	5.5	3.55	6.2	1.90	9		●		

Weitere HM Sorten können Sie in der Sortenübersicht im Kapitel "Technische Hinweise" und der Preisliste finden.

Bestellbeispiel:
für rechte Ausführung und Sorte
RS08.0205.01/AL41F

More carbide grades you can find in the grades summary in the chapter "technical instructions" and in the price list.

order-example:
righthand version and grade
RS08.0205.01/AL41F

MINICUT

Bohrungsbearbeitung

grooving, boring and profiling

Typ Gewindedrehen

metrisches ISO-Gewinde,
Teilprofil, innen

type threading,
metric ISO-thread,
partial profile, internal

D min. 11 / 14 / 16 mm
Steigung P = 0.5 - 3.0

D min. 11 / 14 / 16 mm
pitch P = 0.5 - 3.0

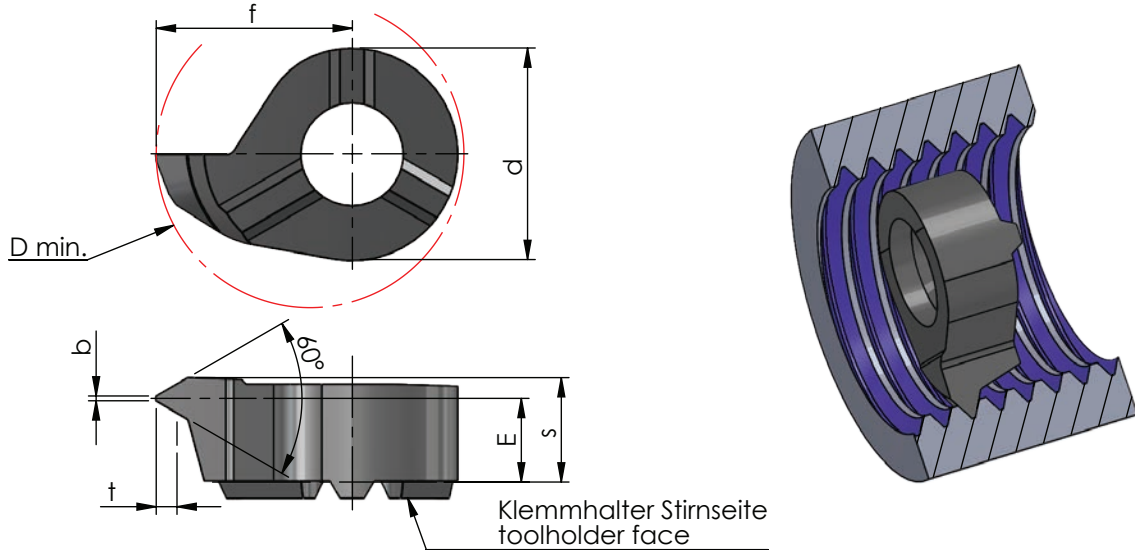

Rechts (R): wie gezeichnet
Links (L): spiegelbildlich

righthand (R): as shown
lefthand version (L): mirror image

Abmessungen in mm

dimensions in mm

Bestellnummer part number	Steigung P pitch P	t	b	f	s	d	E	D min.				Klemmhalter Typ toolholder type
									K10F	AL41F	P18C	
R/L S11.0205.01	0.5-0.75	0.41	0.06	6.7	4.2	8	3.75	11		●		
R/L S11.0510.01	1.0-1.25	0.55	0.12	6.7	4.2	8	3.60	11		●		
R/L S11.0815.01	1.5-1.75	0.81	0.18	6.7	4.2	8	3.40	11		●		611
R/L S11.1020.01	2.0-2.5	1.08	0.25	6.7	4.2	8	3.15	11		●		
R/L S11.1325.01	2.5-3.0	1.35	0.31	6.7	4.2	8	2.95	11		●		
R/L S14.0510.01	1.0-1.25	0.55	0.12	9.0	5.4	9	4.60	14		●		
R/L S14.0815.01	1.5-1.75	0.81	0.18	9.0	5.4	9	4.30	14		●		614
R/L S14.1020.01	2.0-2.5	1.08	0.25	9.0	5.4	9	3.90	14		●		
R/L S14.1325.01	2.5-3.0	1.35	0.31	9.0	5.4	9	3.55	14		●		
R/L S16.0510.01	1.0-1.25	0.55	0.12	10.2	5.4	11	4.80	16		●		
R/L S16.0815.01	1.5-1.75	0.81	0.18	10.2	5.4	11	4.60	16		●		616
R/L S16.1020.01	2.0-2.5	1.08	0.25	10.2	5.4	11	4.35	16		●		
R/L S16.1325.01	2.5-3.0	1.35	0.31	10.2	5.4	11	4.15	16		●		

Weitere HM Sorten können Sie in der Sortenübersicht im Kapitel "Technische Hinweise" und der Preisliste finden.

Bestellbeispiel:
für rechte Ausführung und Sorte
RS14.0510.01/AL41F

More carbide grades you can find in the grades summary in the chapter "technical instructions" and in the price list.

order-example:
righthand version and grade
RS14.0510.01/AL41F

MINICUT

Bohrungsbearbeitung

grooving, boring and profiling

Typ Gewindedrehen

metrisches ISO-Gewinde,
Vollprofil, innen

type threading,
metric ISO-thread,
full profile, internal

D min. 9 / 11 mm
Steigung P = 0.5 - 3.0

D min. 9 / 11 mm
pitch P = 0.5 - 3.0

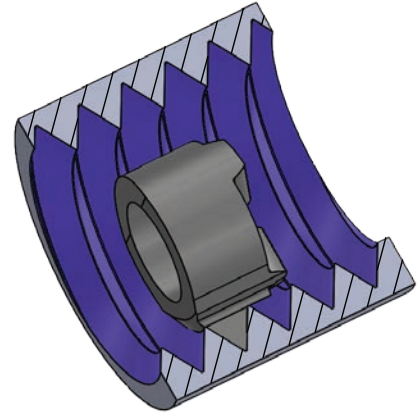
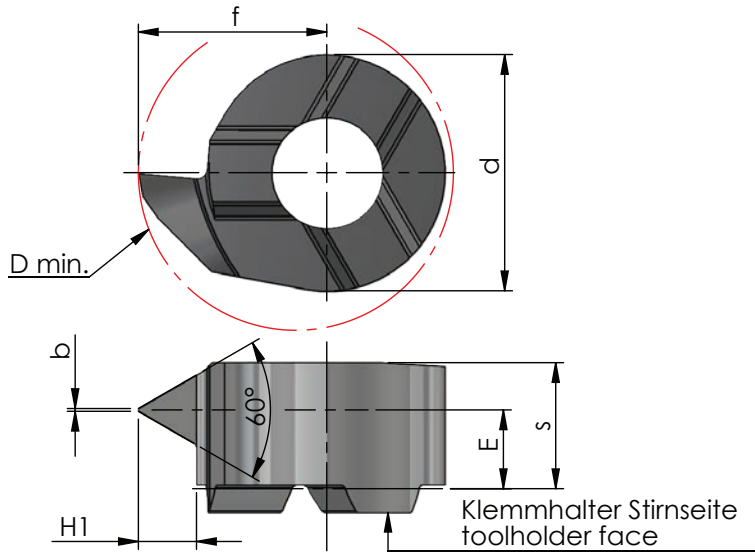

Rechts (R): wie gezeichnet
Links (L): spiegelbildlich

righthand (R): as shown
lefthand version (L): mirror image

Abmessungen in mm

dimensions in mm

Bestellnummer part number	Steigung P pitch P	H1	b	f	s	d	E	D min.	K10F	AL41F	P18C	Klemmhalter Typ toolholder type
R/L S09.0205.02	0.50	0.27	0.06	5.5	3.65	6.2	3.25	9	●			609
R/L S09.0510.02	1.00	0.54	0.12	5.5	3.65	6.2	3.00	9	●			
R/L S09.0815.02	1.50	0.81	0.18	5.5	3.60	6.2	2.80	9	●			
R/L S09.0917.02	1.75	0.95	0.20	5.5	3.60	6.2	2.70	9	●			
R/L S09.1020.02	2.00	1.08	0.25	5.5	3.55	6.2	2.60	9	●			
R/L S09.1325.02	2.50	1.35	0.31	5.5	3.55	6.2	2.50	9	●			
R/L S09.1630.02	3.00	1.62	0.37	5.5	3.55	6.2	2.20	9	●			
R/L S11.0510.02	1.00	0.54	0.12	6.7	4.30	8.0	3.60	11	●		611	
R/L S11.0815.02	1.50	0.81	0.18	6.7	4.30	8.0	3.30	11	●			
R/L S11.1020.02	2.00	1.08	0.25	6.7	4.30	8.0	2.90	11	●			
R/L S11.1325.02	2.50	1.35	0.31	6.7	4.30	8.0	2.95	11	●			
R/L S11.1630.02	3.00	1.62	0.37	6.7	4.30	8.0	2.90	11	●			

Weitere HM Sorten können Sie in der Sortenübersicht im Kapitel "Technische Hinweise" und der Preisliste finden.

Bestellbeispiel:
für rechte Ausführung und Sorte
RS11.1630.02/AL41F

More carbide grades you can find in the grades summary in the chapter "technical instructions" and in the price list.

order-example:
righthand version and grade
RS11.1630.02/AL41F

MINICUT

Bohrungsbearbeitung

grooving, boring and profiling

Typ Gewindedrehen

metrisches ISO-Gewinde,
Vollprofil, innen

type threading,
metric ISO-thread,
full profile, internal

D min. 14 / 16 mm
Steigung P = 0.5 - 4.0

D min. 14 / 16 mm
pitch P = 0.5 - 4.0

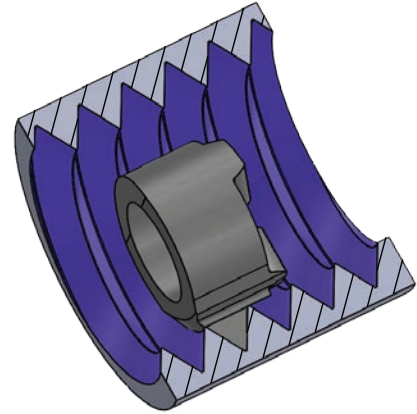
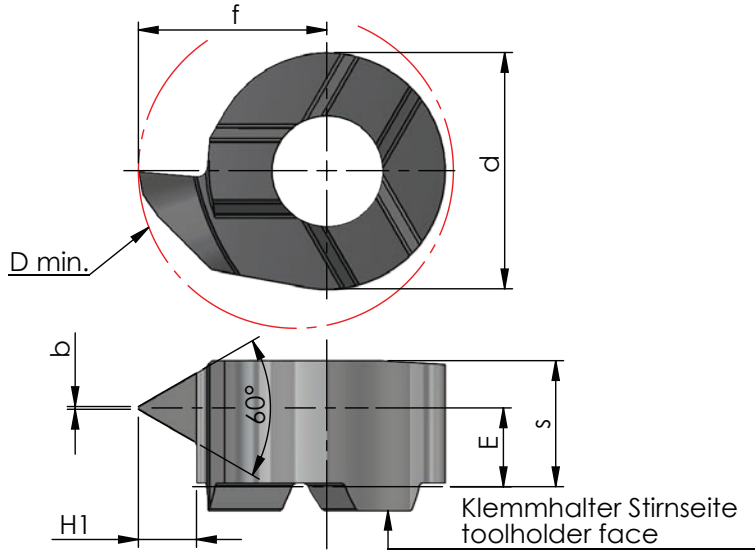

Rechts (R): wie gezeichnet
Links (L): spiegelbildlich

righthand (R): as shown
lefthand version (L): mirror image

Abmessungen in mm

dimensions in mm

Bestellnummer part number	Steigung P pitch P	H1	b	f	s	d	E	D min.				Klemmhalter Typ toolholder type
									K10F	AL41F	P18C	
R/L S14.0205.02	0.5	0.27	0.06	9.0	5.4	9	4.80	14		●		614
R/L S14.0510.02	1.0	0.54	0.12	9.0	5.4	9	4.70	14		●		
R/L S14.0815.02	1.5	0.81	0.18	9.0	5.4	9	4.30	14		●		
R/L S14.1020.02	2.0	1.08	0.25	9.0	5.4	9	4.20	14		●		
R/L S14.1325.02	2.5	1.35	0.31	9.0	5.4	9	3.65	14		●		
R/L S16.0510.02	1.0	0.54	0.12	10.2	5.5	11	4.80	16		●		616
R/L S16.0815.02	1.5	0.81	0.18	10.2	5.5	11	4.30	16		●		
R/L S16.1020.02	2.0	1.08	0.25	10.2	5.5	11	4.05	16		●		
R/L S16.1325.02	2.5	1.35	0.31	10.2	5.5	11	4.20	16		●		
R/L S16.1630.02	3.0	1.62	0.37	10.2	5.5	11	4.00	16		●		
R/L S16.1835.02	3.5	1.89	0.43	10.2	5.5	11	3.90	16		●		
R/L S16.2140.02	4.0	2.16	0.50	10.2	5.5	11	3.60	16		●		

Weitere HM Sorten können Sie in der Sortenübersicht im Kapitel "Technische Hinweise" und der Preisliste finden.

Bestellbeispiel:
für rechte Ausführung und Sorte
RS16.0510.02/AL41F

More carbide grades you can find in the grades summary in the chapter "technical instructions" and in the price list.

order-example:
righthand version and grade
RS16.0510.02/AL41F

MINICUT

Bohrungsbearbeitung

grooving, boring and profiling

Typ Gewindedrehen

NPT Vollprofil,
innen

type threading,
NPT full profile, internal

D min. 8 mm

D min. 8 mm

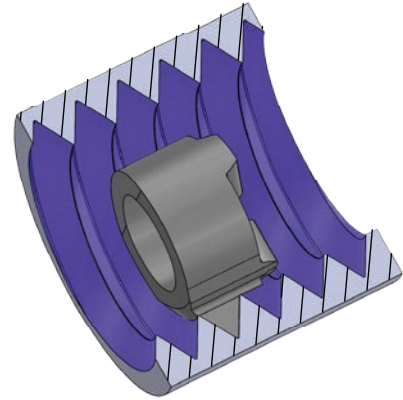
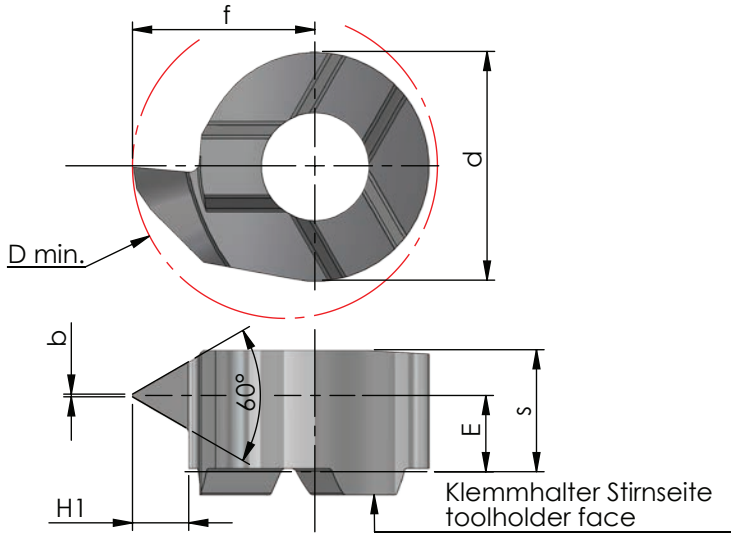

Rechts (R): wie gezeichnet
Links (L): spiegelbildlich

righthand (R): as shown
lefthand version (L): mirror image

Abmessungen in mm

dimensions in mm



Bestellnummer part number	Steigung P pitch P	H1	Gang / Zoll threads / inch	b	f	s	d	E	D min.	K10F	AL41F	P18C	Klemmhalter Typ toolholder type
R/L S08.NP14.02	1.814	1.48	14	0.07	4.8	3.2	6	2.0	8	●			
R/L S08.NP18.02	1.411	1.19	18	0.05	4.8	3.5	6	2.6	8	●			608
R/L S08.NP27.02	0.940	0.80	27	0.04	4.8	3.5	6	2.8	8	●			

Weitere HM Sorten können Sie in der Sortenübersicht im Kapitel "Technische Hinweise" und der Preisliste finden.

Bestellbeispiel:
für rechte Ausführung und Sorte
RS08.NP14.02/AL41F

More carbide grades you can find in the grades summary in the chapter "technical instructions" and in the price list.

order-example:
righthand version and grade
RS08.NP14.02/AL41F

MINICUT

Bohrungsbearbeitung

grooving, boring and profiling

Typ Gewindedrehen

Whitworth-Gewinde,
Vollprofil, innen

D min. 11 / 14 / 16 mm

type threading,
Whitworth thread,
full profile, internal

D min. 11 / 14 / 16 mm

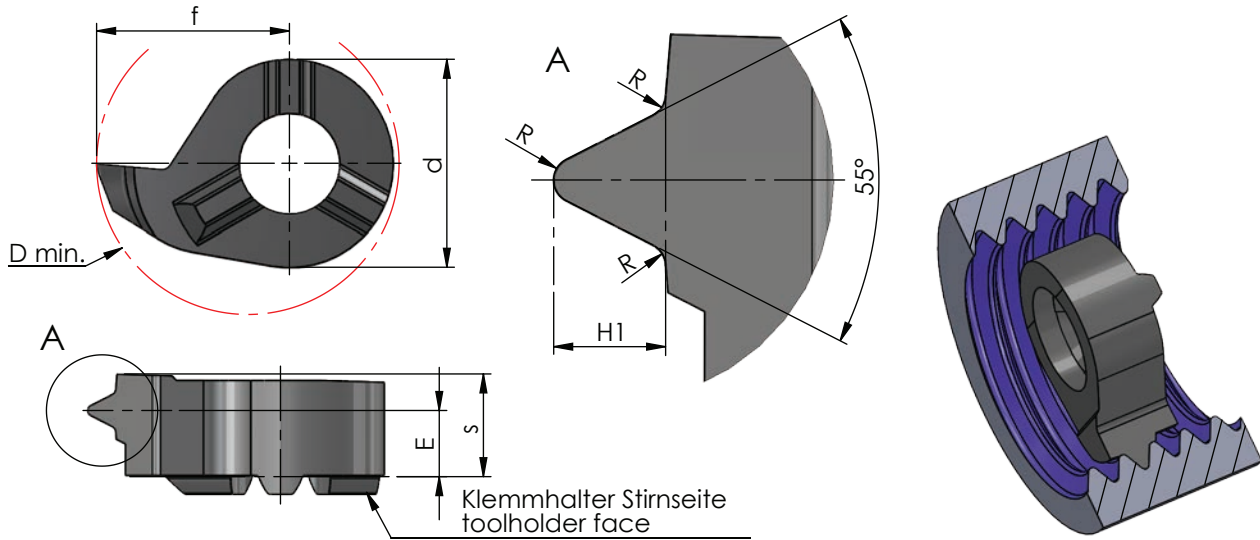

Rechts (R): wie gezeichnet
Links (L): spiegelbildlich

righthand (R): as shown
lefthand version (L): mirror image

Abmessungen in mm

dimensions in mm

Bestellnummer part number	Steigung P pitch P	H1	Gang / Zoll threads / inch	R	f	s	d	E	D min.				Klemmhalter Typ toolholder type
										K10F	AL41F	P18C	
R/L S11.0813.19	1.337	0.85	19	0.18	6.7	4.3	8	2.7	11	●			
R/L S11.1118.14	1.814	1.16	14	0.24	6.7	4.3	8	3.0	11	●			611
R/L S14.0813.19	1.337	0.85	19	0.18	9.0	5.35	9	3.8	14	●			614
R/L S14.1118.14	1.814	1.16	14	0.24	9.0	5.40	9	3.6	14	●			
R/L S16.1118.14	1.814	1.16	14	0.24	10.2	5.4	11	3.9	16	●			616
R/L S16.1423.11	2.309	1.48	11	0.31	10.2	5.4	11	3.5	16	●			

Weitere HM Sorten können Sie in der Sortenübersicht im Kapitel "Technische Hinweise" und der Preisliste finden.

Bestellbeispiel:
für rechte Ausführung und Sorte
RS16.1423.11/AL41F

More carbide grades you can find in the grades summary in the chapter "technical instructions" and in the price list.

order-example:
righthand version and grade
RS16.1423.11/AL41F

MINICUT

Bohrungsbearbeitung

grooving, boring and profiling

Typ Gewindedrehen

Trapezgewinde,
Teilprofil, innen

type threading,
trapezoidal thread,
partial profile, internal

D min. 9 / 10 / 11 mm
Steigung P = 1.5 - 4.0

D min. 9 / 10 / 11 mm
pitch P = 1.5 - 4.0

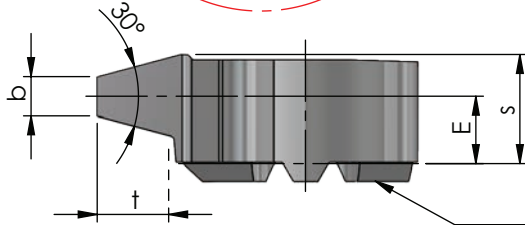
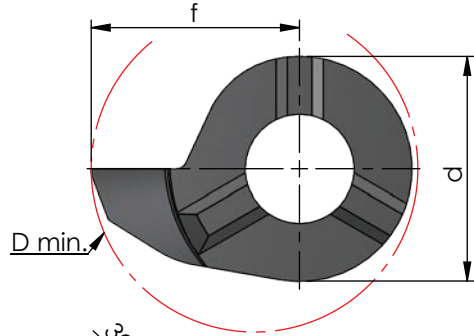

Klemmhalter Stirnseite
toolholder face

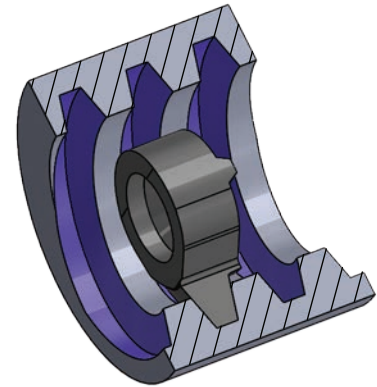

Rechts (R): wie gezeichnet
Links (L): spiegelbildlich

righthand (R): as shown
lefthand version (L): mirror image

Abmessungen in mm

dimensions in mm



Bestellnummer part number	Steigung P pitch P	t	b	f	s	d	E	D min.	Klemmhalter Typ toolholder type			
									K10F	AL41F	P18C	
R/L S09.1015.01	1.5	0.90	0.47	5.5	3.55	6.2	3.00	9	●	●	●	609
R/L S09.1220.01	2.0	1.25	0.60	5.5	3.55	6.2	2.85	9	●	●	●	
R/L S09.1730.01	3.0	1.75	0.96	5.5	3.55	6.2	2.25	9	●	●	●	
R/L S09.2240.01	4.0	2.25	1.33	6.5	3.55	6.2	2.25	10	●	●	●	
R/L S11.1015.01	1.5	0.90	0.47	6.7	4.30	8.0	3.7	11	●	●	●	611
R/L S11.1220.01	2.0	1.25	0.60	6.7	4.30	8.0	3.5	11	●	●	●	
R/L S11.1730.01	3.0	1.75	0.96	6.7	4.30	8.0	3.2	11	●	●	●	
R/L S11.2240.01	4.0	2.25	1.33	6.7	4.00	8.0	2.6	11	●	●	●	

Weitere HM Sorten können Sie in der Sortenübersicht im Kapitel "Technische Hinweise" und der Preisliste finden.

Bestellbeispiel:
für rechte Ausführung und Sorte
RS09.1015.01/AL41F

More carbide grades you can find in the grades summary in the chapter "technical instructions" and in the price list.

order-example:
righthand version and grade
RS09.1015.01/AL41F

MINICUT

Bohrungsbearbeitung

grooving, boring and profiling

Typ Gewindedrehen

Trapezgewinde,
Teilprofil, innen

type threading,
trapezoidal thread,
partial profile, internal

D min. 14 / 16 mm
Steigung P = 2.0 - 6.0

D min. 14 / 16 mm
pitch P = 2.0 - 6.0

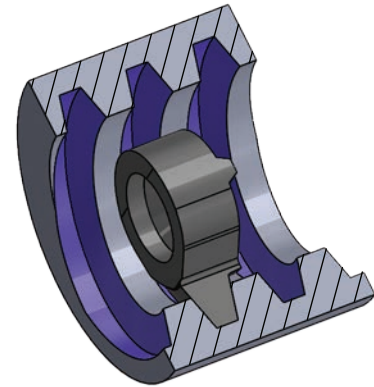
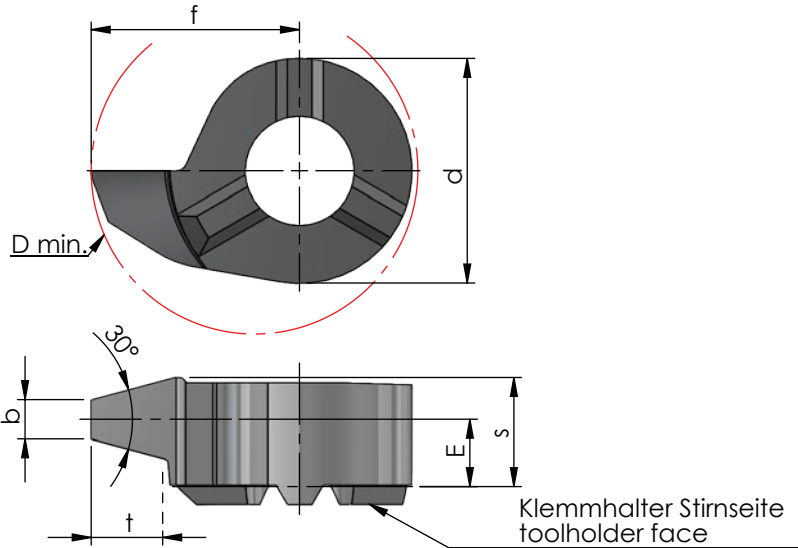

Rechts (R): wie gezeichnet
Links (L): spiegelbildlich

righthand (R): as shown
lefthand version (L): mirror image

Abmessungen in mm

dimensions in mm

Bestellnummer part number	Steigung P pitch P	t	b	f	s	d	E	D min.	Klemmhalter Typ toolholder type		
									K10F	AL41F	P18C
R/L S14.1220.01	2.0	1.25	0.60	9.0	5.3	9.0	4.3	14	●		
R/L S14.1730.01	3.0	1.75	0.96	9.0	5.3	9.0	4.0	14	●		
R/L S14.2240.01	4.0	2.25	1.33	9.0	5.3	9.0	4.0	14	●		614
R/L S14.2750.01	5.0	2.75	1.69	9.0	5.3	9.0	3.55	14	●		
R/L S16.1220.01	2.0	1.25	0.60	9.7	5.5	11	4.5	16	●		
R/L S16.1730.01	3.0	1.75	0.96	9.7	5.5	11	4.3	16	●		
R/L S16.2240.01	4.0	2.25	1.33	9.7	5.5	11	4.0	16	●		616
R/L S16.2750.01	5.0	2.75	1.69	10.2	5.5	11	3.6	16	●		
R/L S16.3560.01	6.0	3.50	1.92	10.2	5.5	11	3.3	16	●		

Weitere HM Sorten können Sie in der Sortenübersicht im Kapitel "Technische Hinweise" und der Preisliste finden.

Bestellbeispiel:
für rechte Ausführung und Sorte
RS14.1220.01AL41F

More carbide grades you can find in the grades summary in the chapter "technical instructions" and in the price list.

order-example:
righthand version and grade
RS14.1220.01AL41F

MINICUT

Bohrungsbearbeitung

grooving, boring and profiling

Typ Axialstechen

allgemein

type face grooving

D min. 14 / 18 mm
 Stechtiefe t max. 6 / 10 mm
 Nutbreite bis 3.0 / 4.0 mm

D min. 14 / 18 mm
 depth of groove t max. 6 / 10 mm
 width of groove up to 3.0 / 4.0 mm

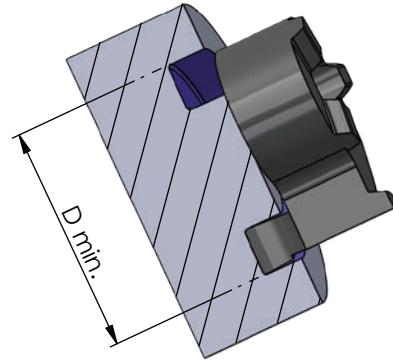
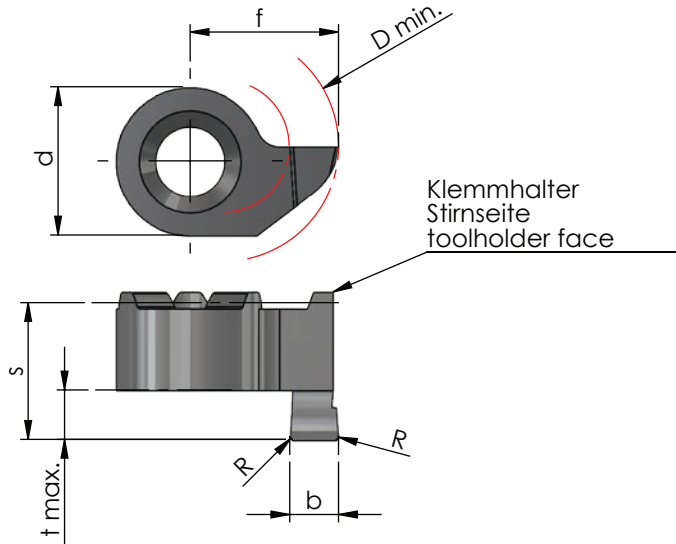

Rechts (R): wie gezeichnet
 Links (L): spiegelbildlich

righthand (R): as shown
 lefthand version (L): mirror image

Abmessungen in mm

dimensions in mm

Bestellnummer part number	b+0.03	f	R	s	d	t max.	D min.				Klemmhalter Typ toolholder type
								K10F	AL41F	P18C	
R/L S014.1410.00	1.0	9	-	8.3	9	1.5	14		●		614 614.A
R/L S014.1415.02	1.5	9	0.2	8.3	9	2.5	14	●	●		
R/L S014.1420.02	2.0	9	0.2	8.3	9	3.0	14	●	●		
R/L S014.1425.02	2.5	9	0.2	8.3	9	3.0	14	●	●		
R/L S014.1430.02	3.0	9	0.2	8.3	9	3.0	14		●		
R/L S014.1420.52	2.0	9	0.2	10.3	9	5.0	14	●	●		
R/L S014.1425.52	2.5	9	0.2	10.3	9	5.0	14	●	●		
R/L S014.1430.52	3.0	9	0.2	10.3	9	5.0	14	●	●		
R/- S014.1430.62	3.0	9	0.2	11.3	9	6.0	14		●		
R/L S018.1830.02	3.0	11	0.2	15.8	11	10	18		●		618
R/L S018.1840.02	4.0	11.5	0.2	15.8	11	10	18		●		618.A

Weitere HM Sorten können Sie in der Sortenübersicht im Kapitel "Technische Hinweise" und der Preisliste finden.

Bestellbeispiel:
 für rechte Ausführung und Sorte
 RS014.1410.00/AL41F

More carbide grades you can find in the grades summary in the chapter "technical instructions" and in the price list.

order-example:
 righthand version and grade
 RS014.1410.00/AL41F

MINICUT

Bohrungsbearbeitung

grooving, boring and profiling

Typ Axialstechen

am Zapfen vorbei

type face grooving,
in pivots

D min. 12 / 16 mm
Stechtiefe t max. 6 / 10 mm
Nutbreite bis 3.0 / 4.0 mm

D min. 12 / 16 mm
depth of groove t max. 6 / 10 mm
width of groove up to 3.0 / 4.0 mm

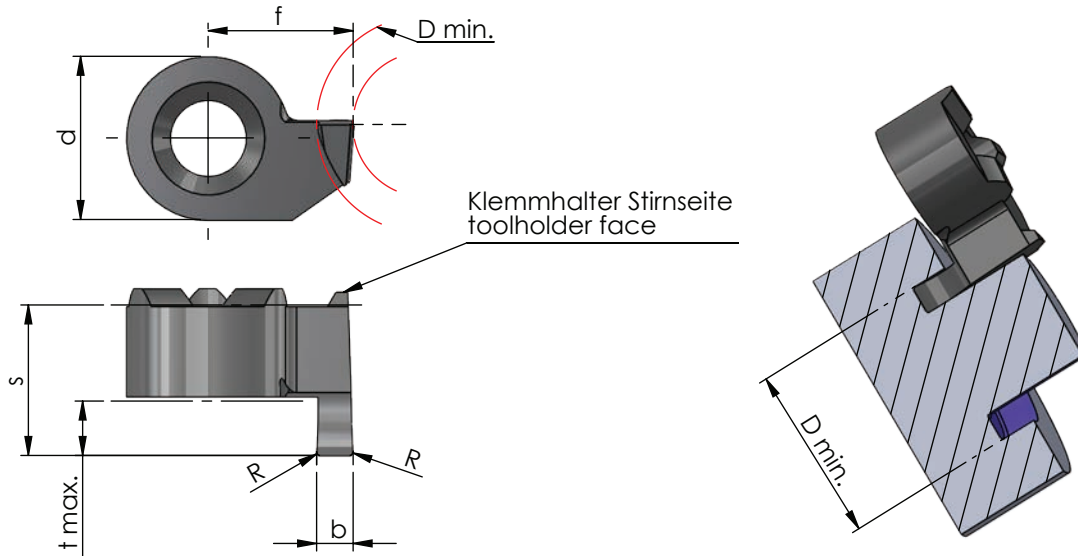

Rechts (R): wie gezeichnet
Links (L): spiegelbildlich

righthand (R): as shown
lefthand version (L): mirror image

Abmessungen in mm

dimensions in mm

Bestellnummer part number	b+0.03	b (inch)	f	R	s	d	t max.	D min.	K10F	AL41F	P18C	Klemmhalter Typ toolholder type
R/L S014.1210.00	1.0		7.0	-	8.3	9	1.5	12	●	●		614 614.A
R/L S014.1215.02	1.5		7.5	0.2	8.3	9	2.5	12	●	●		
R/L S014.U219.02	1.98	0.078"	8.0	0.2	8.3	9	3.0	12		●		
R/L S014.1220.02	2.0		8.0	0.2	8.3	9	3.0	12	●	●		
R/L S014.U223.02	2.39	0.094"	8.4	0.2	8.3	9	3.0	12		●		
R/L S014.1225.02	2.5		8.5	0.2	8.3	9	3.0	12		●		
R/L S014.1230.02	3.0		9.0	0.2	8.3	9	3.0	12		●		
R/L S014.U231.02	3.18	0.125"	9.2	0.2	8.3	9	3.0	12		●		
R/L S014.1220.52	2.0		8.0	0.2	10.3	9	5.0	12	●	●		
R/L S014.1225.52	2.5		8.5	0.2	10.3	9	5.0	12		●		
R/L S014.1230.52	3.0		9.0	0.2	10.3	9	5.0	12	●	●		
R/- S014.1230.62	3.0		9.0	0.2	11.3	9	6.0	12		●		
R/L S018.1630.02	3.0		11	0.2	15.8	11	10	16		●		618 618.A
R/L S018.1640.02	4.0		12	0.2	15.8	11	10	16		●		

Weitere HM Sorten können Sie in der Sortenübersicht im Kapitel "Technische Hinweise" und der Preisliste finden.

Bestellbeispiel:
für rechte Ausführung und Sorte
RS014.1210.00/AL41F

More carbide grades you can find in the grades summary in the chapter "technical instructions" and in the price list.

order-example:
righthand version and grade
RS014.1210.00/AL41F

MINICUT

Bohrungsbearbeitung

grooving, boring and profiling

Typ Axialstechen

Vollradius

type face grooving,
full radius

D min. 14 mm
Stechtiefe t max. 5 mm
Nutbreite bis 3.0 mm

D min. 14 mm
depth of groove t max. 5 mm
width of groove up to 3.0 mm

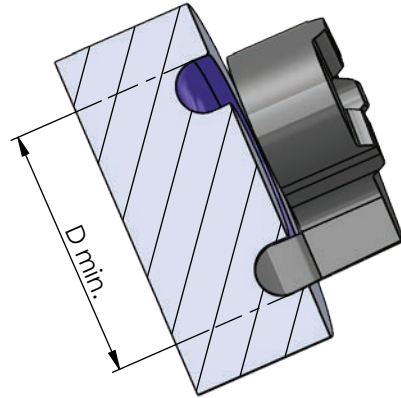
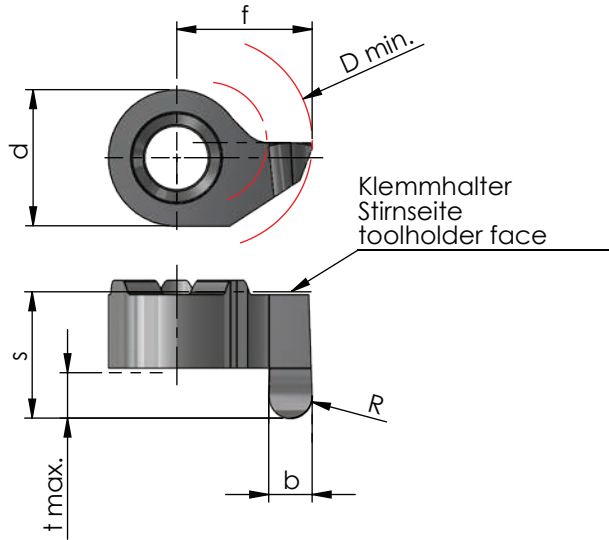

Rechts (R): wie gezeichnet
Links (L): spiegelbildlich

righthand (R): as shown
lefthand version (L): mirror image

Abmessungen in mm

dimensions in mm



Bestellnummer part number	b		f	R	s	d	t max.	D min.	K10F AL41F P18C	Klemmhalter Typ toolholder type
	b+0.03	b (inch)								
R/L S014.1410.05	1.0		9	0.5	8.3	9	1.5	14	●	614 614A
R/L S014.U411.05	1.17	0.046"	9	0.58	8.3	9	1.5	14	●	
R/L S014.1416.08	1.6		9	0.8	8.3	9	2.5	14	●	
R/L S014.1420.10	2.0		9	1.0	8.3	9	3.0	14	●	
R/L S014.1425.12	2.5		9	1.25	8.3	9	3.0	14	●	
R/L S014.1430.15	3.0		9	1.5	8.3	9	3.0	14	●	
R/L S014.1420.50	2.0		9	1.0	10.3	9	5.0	14	●	
R/L S014.1425.50	2.5		9	1.25	10.3	9	5.0	14	●	
R/L S014.1430.50	3.0		9	1.5	10.3	9	5.0	14	●	

Weitere HM Sorten können Sie in der Sortenübersicht im Kapitel "Technische Hinweise" und der Preisliste finden.

Bestellbeispiel:
für rechte Ausführung und Sorte
RS014.1410.05/AL41F

More carbide grades you can find in the grades summary in the chapter "technical instructions" and in the price list.

order-example:
righthand version and grade
RS014.1410.05/AL41F

MINICUT

Bohrungsbearbeitung

grooving, boring and profiling

Typ Axialstechen

am Zapfen vorbei,
Vollradius

type face grooving,
in pivots, full radius

D min. 12 mm
Stechtiefe t max. 5 mm
Nutbreite bis 3.0 mm

D min. 12 mm
depth of groove t max. 5 mm
width of groove up to 3.0 mm

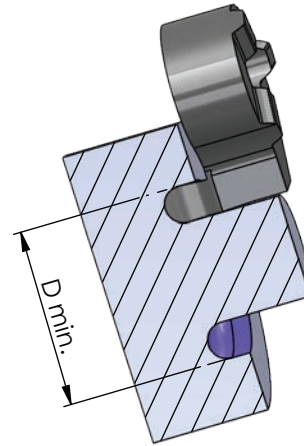
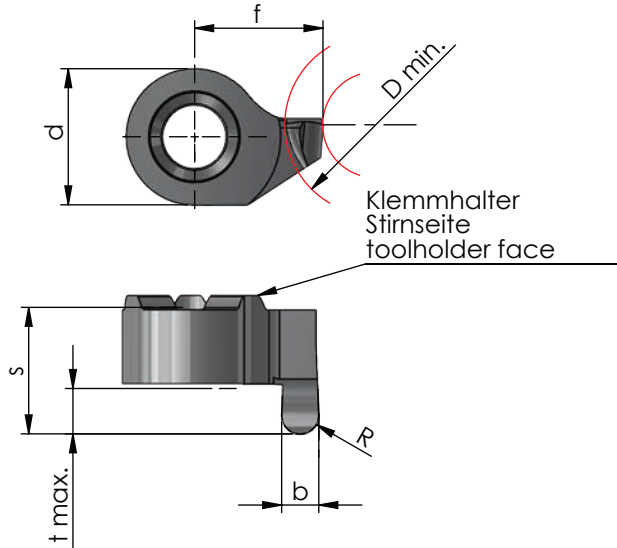

Rechts (R): wie gezeichnet
Links (L): spiegelbildlich

righthand (R): as shown
lefthand version (L): mirror image

Abmessungen in mm

dimensions in mm

Bestellnummer part number	b+0.03	f	R	s	d	t max.	D min.	Klemmhalter Typ toolholder type		
								K10F	AL41F	P18C
R/L S014.1210.05	1.0	7.0	0.5	8.3	9	1.5	12	●		
R/L S014.1216.08	1.6	7.6	0.8	8.3	9	2.5	12	●		614
R/L S014.1220.10	2.0	8.0	1.0	8.3	9	3.0	12	●		
R/L S014.1225.12	2.5	8.5	1.25	8.3	9	3.0	12	●		
R/L S014.1230.15	3.0	9.0	1.5	8.3	9	3.0	12	●		
R/L S014.1220.50	2.0	8.0	1.0	10.3	9	5.0	12	●		614
R/L S014.1225.50	2.5	8.5	1.25	10.3	9	5.0	12	●		614A
R/L S014.1230.50	3.0	9.0	1.5	10.3	9	5.0	12	●		

Weitere HM Sorten können Sie in der Sortenübersicht im Kapitel "Technische Hinweise" und der Preisliste finden.

Bestellbeispiel:
für rechte Ausführung und Sorte
RS014.1210.05/AL41F

More carbide grades you can find in the grades summary in the chapter "technical instructions" and in the price list.

order-example:
righthand version and grade
RS014.1210.05/AL41F

MINICUT

Bohrungsbearbeitung

grooving, boring and profiling

Impressionen

impressions

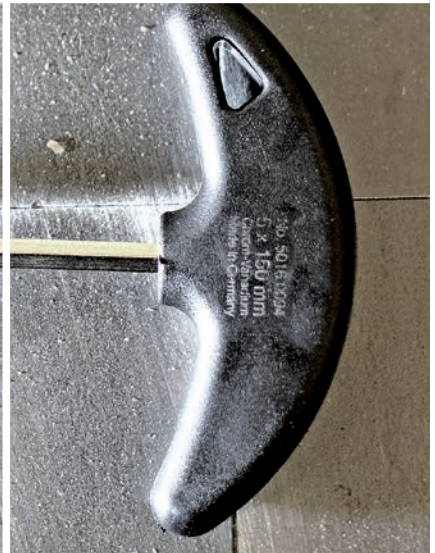
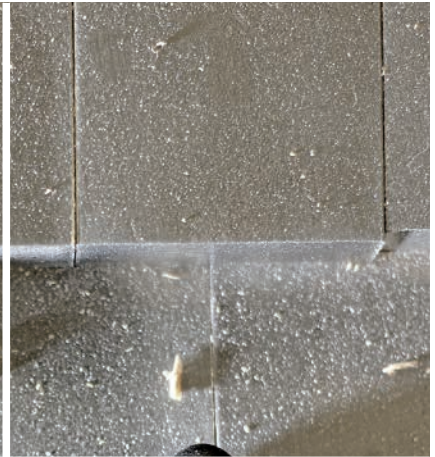

MINICUT

Bohrungsbearbeitung

grooving, boring and profiling

Sets

D min. 8 mm

D min. 11 mm

Bestellnummer
part number

Inhalt
Content

K10F
AL41F
P18C
CN45F

SET-MC08-LF/R



Beispielfoto
exemplary presentation

- Ausdrehen und Kopieren (Rechte Ausführung)
- Stechdrehen (Rechte Ausführung)
- Gewindedrehen (Rechte Ausführung)

- boring and profiling (righthand version)
- grooving (righthand version)
- threading (righthand version)

Halter / toolholder:

1 x 608.0016.1E.ST

Schneideinsatz / insert:

1 x RS008.0090
1 x RS08.008R04
1 x RS08.1846.02
1 x RS08.3046.02
1 x RS08.0815.01



Bestellnummer
part number

Inhalt
Content

K10F
AL41F
P18C
CN45F

SET-MC11-LF/R



Beispielfoto
exemplary presentation

- Ausdrehen und Kopieren (Rechte Ausführung)
- Stechdrehen (Rechte Ausführung)
- Gewindedrehen (Rechte Ausführung)

- boring and profiling (righthand version)
- grooving (righthand version)
- threading (righthand version)

Halter / toolholder:

1 x 611.0016.2E.ST

Schneideinsatz / insert:

1 x RS011.0090
1 x RS11.008R04
1 x RS11.1867.02
1 x RS11.3067.02
1 x RS11.1020.01



MINICUT

Bohrungsbearbeitung

grooving, boring and profiling

Sets

D min. 14 mm



Bestellnummer
part number

Inhalt
Content

K10F
AL41F
P18C
CN45F

SET-MC14-LF/R



- Ausdrehen und Kopieren (Rechte Ausführung)
- Stechdrehen (Rechte Ausführung)
- Vorstechen und Fasen (Rechte Ausführung)
- Axialstechen (Rechte Ausführung)
- boring and profiling (righthand version)
- grooving (righthand version)
- pregrooving and chamfering (righthand version)
- face grooving (righthand version)

Halter / toolholder:

1 x 614.0016.3E.ST

Schneideinsatz / insert:

- 1 x RS014.0300
- 1 x RS14.030R15
- 1 x RS14.1867.02
- 1 x RS14.0815.45
- 1 x RS014.1430.52



Bestellbeispiel:
SET-MC14-LF/R

order-example:
SET-MC14-LF/R

MINICUT

Bohrungsbearbeitung

grooving, boring and profiling

Technische Hinweise

Schnittwerte und Anzahl der Schnitte beim Gewindedrehen

Technical instructions, Cutting data and number of passes for threading

Empfohlene Anzahl der Schnitte

Die Anzahl der Schnitte ist nur ein Richtwert für das Gewindedrehen. Um eine möglichst lange Standzeit der Schneide zu erreichen beachten Sie bitte die Erklärungen für die Zustellung. Leerschnitte zum Fertigschneiden sind in dieser Tabelle nicht berücksichtigt.

Recommended number of passes

The number of passes is only a recommendation for threading. To reach a good tool life you have to mention the explanation for the infeed. Finishing passes are not considered in that chart.

		Stahl (Festigkeit N/mm ²) Steel (N/mm ² tensile strength)					rostfreier Stahl stainless steel	Guss cast iron	Alumini- um alumini- um
		400-500	500-700	700-850	850-1150	>1150			
V m/min		160	140	120	90	70	90	100	300
Steigung P Pitch P		Anzahl der Schnitte number of passes							
mm	Gg/" TPI								
0,5	48	5	5	5	5	8	8	5	5
0,8	32	6	6	6	6	8	8	6	6
1	24	7	7	7	7	8	8	7	7
1,25	20-19	8	8	8	8	10	10	8	8
1,5	16	10	10	10	10	12	12	10	10
1,75	14	12	12	12	12	14	14	12	12
2	12-11	13	13	13	13	15	15	13	13
2,5	10	15	15	16	16	18	18	16	15
3 - 3,5	8	16	16	17	17	20	20	17	16
4		18	18	19	19	22	22	19	18
5		20	20	21	21	24	24	21	20
6		22	22	23	23	26	26	23	22

MINICUT

Bohrungsbearbeitung

grooving, boring and profiling

Technische Hinweise

Gewinde schneiden

Technical instructions,
threading

Vorschubrichtung

Mit jedem Schneideinsatz für das Gewindedrehen kann sowohl ein Rechts- wie auch ein Linksgewinde geschnitten werden. Hierbei ist folgende Vorschubrichtung zu beachten:

Feed direction

Every insert can be used for right- and lefthand thread. You only have to consider the following feed direction:

Rechtsgewinde
thread right hand

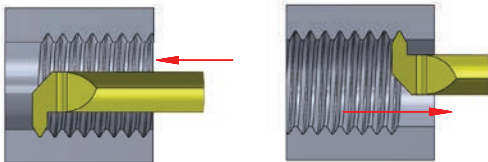

Linksgewinde
thread left hand

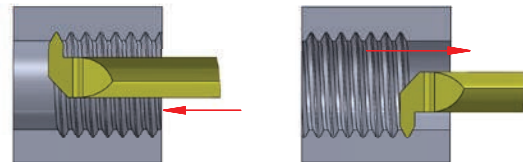

Zustellungsvarianten

Radiale Zustellung	wechselnde Flankenzustellung	einseitige Flankenzustellung
Die meist verwendete Methode um Gewinde herstellen. Beide Schneiden sind gleichzeitig im Eingriff.	Die Schneiden werden wechselnd eingesetzt.	Nur eine Schneidewird für die komplette Gewindeerstellung eingesetzt.
Problematische Spanbildung, dadurch hohe Schnittkräfte und Verschleiß am Werkzeug und Bauteil.	Reduzierung des Schnittdrucks, höhere Standzeit und bessere Spanbildung.	Reduzierung des Schnittdrucks und bessere Spanbildung, aber einseitige Abnutzung des Werkzeugs.

Infeed possibilities

Radial infeed	alternating flank infeed	flank infeed
The most used method for threading. both sides are at the same time in process.	The flanks are alternating used	Only one cutting edge is used for the complete thread
Problematic chip education, high cutting force and weariness at insert and work piece	Reduced cutting force, higher state time and chip education	Reduced cutting force and better chip education, but one-sided weariness

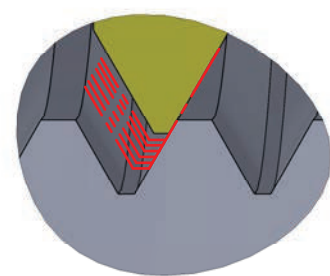
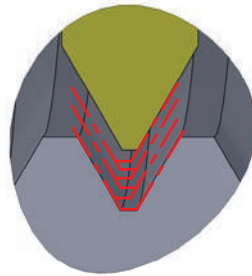
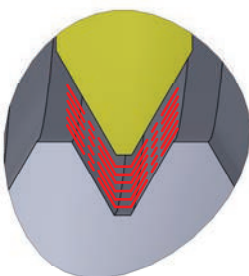

MINICUT

Bohrungsbearbeitung

grooving, boring and profiling

Technische Hinweise

Hartmetallsorten und Beschichtungen

Technical instructions,
carbide grades and coatings

K10F

Universell einsetzbares Feinkornhartmetall mit guter Verschleißfestigkeit. Unbeschichtet geeignet für Anwendungen mit niedrigen und mittleren Schnittgeschwindigkeiten, sowie die Bearbeitung von Nicht-eisenmetallen.

All purpose micrograin carbide with good abrasion resistance. Uncoated for applications with low or medium cutting speeds and machining of non-ferrous materials.

CBN

Zähe CBN-Sorte für Anwendungen mit niedrigen Schnittgeschwindigkeiten. Geeignet für gehärtete Stähle, unterbrochene Schnitte und Grauguss.

Ductile CBN grade for applications with lower cutting speed. Suitable for hardened steel, interrupted cuts and cast iron.

CN45F

Universell einsetzbare PVD-TiN-Beschichtung. Diese Allround-Sorte ist für niedrige und mittlere Schnittgeschwindigkeiten mit Einschränkung bei NE-Metallen

PVD-TiN coating - all purpose, all around grade is suitable for low and medium cutting speed with restrictions on non-ferrous materials.

AL41F

Sehr universell einsetzbare TiAlN-Beschichtung mit hoher Temperaturbeständigkeit bei hoher Härte. Sehr gut geeignet auch für NE-Metalle.

TiAlN coating - very universal with a high resistance to high temperature and hardness. Very suitable also for non-ferrous metals.

PD2F

Beschichtung für den universellen Einsatz bei niedrigen und mittleren Schnittgeschwindigkeiten.

Coating for universal use with medium and low speed.

XC2A

Beschichtung mit einer excellenten Warmhärte, Oxidationsbeständigkeit und thermischen Isolationsfähigkeit. Ideal für Hartzerspannung >60HRC

Coating with excellent hot hardness, high oxidation resistance and thermal insulation capacity. Perfect for hard machining >60 HRC.

MINICUT

Bohrungsbearbeitung

grooving, boring and profiling

Technische Hinweise

Hartmetallsorten und Beschichtungen

Technical instructions,
carbide grades and coatings

P01C

Beschichtung für die Bearbeitung in zähen Materialien bei niedrigen und mittleren Schnittgeschwindigkeiten.

Coating for the processing in tough material with medium or low cutting speed

P03C

Beschichtung für die Bearbeitung von schwer zerspanbaren Materialien. Sehr gut auch für die Trockenbearbeitung geeignet.

Coating for materials which are difficult to machine. Perfect to use for dry machining.

P07C

Beschichtung für die Bearbeitung von Titan, Edelstahl und Molybdän.

Coating to machine titanium, stainless steel and molybdenum.

P18C

Universell einsetzbare Hochleistungsschicht mit hoher Oxidationsbeständigkeit, Verschleißfestigkeit und Warmhärte.

Very universal high performance coating with high oxidation resistance, wear resistance and hot hardness resistance.

NEME

Beschichtung für die Bearbeitung von Aluminium, Al-Legierungen, NE-Metallen und Composite-Werkstoffen.

Coating for machining aluminium, alloys, non-ferrous metals and composite materials.



MINICUT

Bohrungsbearbeitung

grooving, boring and profiling

Technische Hinweise

Schnittdaten

Technical instructions,
cutting data

	Werkstoff	Festigkeit	Werkstoff-Nr	Werkstoffbezeichnung	Werkstoff-Nr
P	Allgemeiner Baustahl	< 800 N/mm2	1.0037	St37-2	1.0570
	Automatenstahl	< 800 N/mm2	1.0718	9SMnPb28	1.0727
	Einsatzstahl unlegiert	< 800 N/mm2	1.0401	C15	1.0481
	Einsatzstahl legiert	< 1000 N/mm2	1.7331	16MnCr5 (EC80)	1.7015
	Vergütungsstahl unlegiert	< 850 N/mm2	1.0503	C45	1.1191
	Vergütungsstahl unlegiert	< 1000 N/mm2	1.0601	C60	1.1221
	Vergütungsstahl legiert	< 800 N/mm2	1.5131	50MnSi4	1.7030
	Vergütungsstahl legiert	< 1300 N/mm2	1.5755	31NiCr14	1.7033
	Stahlguss	< 850 N/mm2	0.9650	G-X260Cr27	1.6750
	Nitrierstahl	< 1000 N/mm2	1.8504	34CrAl6	1.8507
	Nitrierstahl	< 1200 N/mm2	1.8515	31CrMo12	1.8523
	Wälzlagerstahl	< 1200 N/mm2	1.3505	100Cr6 (W3)	1.3543
	Federstahl	< 1200 N/mm2	1.5026	55Si7	1.7176
	Schnellarbeitsstahl	< 1300 N/mm2	1.3344	S 6-5-3	1.3255
	Werkzeugstahl für Kaltarbeit	< 1300 N/mm2	1.2312	40CrMnMoS8 6	1.2379
	Werkzeugstahl für Warmbeit	< 1300 N/mm2	1.2343	X38CrMoV 5 1	1.2767
M	Stahl und Stahlguss rostfrei geschwefelt	< 850 N/mm2	1.4305	X8CrNiS18 9	1.4105
	Nichtrostender Stahl, ferritisch	< 750 N/mm2	1.4510	X3CrTi17	1.4528
	Nichtrostender Stahl, martensitisch	< 900 N/mm2	1.4034	X46Cr13	1.4116
	Nichtrost. Stahl, ferritisch/martensit.	<1100 N/mm2	1.4313	X3CrNi13-4	1.4028
	Nichtrost. Stahl, austenitisch/ferritisch	< 850 N/mm2	1.4460	X8CrNiMo27 5	1.4821
	Nichtrostender Stahl, austenitisch	< 750 N/mm2	1.4301	X5CrNi18-10	1.4571
K	Hitzebeständig	< 1100 N/mm2	1.4747	X80CrNiSi20	1.4876
	Grauguss mit Lammellengraphit	100-350N/mm2	0.6010	GG10	0.6025
	Grauguss mit Lammellengraphit	300-1000N/mm2	0.6030	GG30	0.6045
	Kugelgraphitguss	300-500N/mm2	0.7040	GGG40	0.7050
	Kugelgraphitguss	550-800N/mm2	0.7060	GGG60	0.7080
	Temperguss weis	350-450N/mm2	0.8035	GTW35	0.8045
	Temperguss weis	500-650N/mm2	0.8055	GTW55	0.8065
	Temperguss schwarz	350-450N/mm2	0.8135	GTS35	0.8145
N	Temperguss schwarz	500-700N/mm2	0.8155	GTS55	0.8170
	Aluminium (unlegiert, niedrig legiert)	< 350 N/mm2	3.0255	Al99,5	3.3308
	Aluminiumlegierungen < 0,5% Si	< 500 N/mm2	3.0515	AlMn1	3.1355
	Aluminiumlegierungen 0,5-10% Si	< 400 N/mm2	3.2152	GD-AlSi6Cu4	3.2373
	Aluminiumlegierungen 10-15% Si	< 400 N/mm2	3.2381	G-AlSi10Mg	3.5562
	Aluminiumlegierungen > 15% Si	< 400 N/mm2		G-AlSi17Cu4	
	Kupfer (unlegiert, niedrig legiert)	< 350 N/mm2	2.0060	E-Cu57	2.0090
	Kupfer-Knetlegierungen	< 700 N/mm2	2.0240	CuZn15	2.0265
	Kupfer-Sonderlegierungen	< 200 HB	2.0916	CuAl5	2.1525
	Kupfer-Sonderlegierungen	< 300HB	2.0978	CuAl11Ni6Fe5	
	Kupfer-Sonderlegierungen	> 300 HB	2.1247	CuBe2F125	
	Messing kurzspanend, Bronze, Rotguss	< 600 N/mm2	2.0360	CuZn40 (Ms60)	2.0380
	Messing langspanend	< 600 N/mm2	2.0335	CuZn36 (Ms63)	2.1293
	Thermoplaste			Delrin, Hostalen	
	Duroplaste			Ferrozell, Bakelit	
	Faserverstärkte Kunststoffe			GFK (Glasfaserverstärkt)	
	Magnesium und Magnesiumlegierungen	< 850 N/mm2	3.5200	M2, MgMn2	3.5612
	Graphit			C8000, R8500X	
Wolfram und Wolframlegierungen			W-NiFe (Densimet W)		
Molybdän und Molybdänlegierungen			Mo , Mo-50Re		
S	Reinnickel		1.3911	RNi24	1.3927
	Nickellegierungen		1.3912	Ni36 (Invar)	1.3924
	Nickellegierungen	< 850 N/mm2	2.4360	S-NiCu 30 Fe	
	Nickel-Chromlegierungen		2.4886	SG-NiMo16Cr16W	2.4610
	Nickel- und Kobaltlegierungen	< 1300 N/mm2	2.4632	NiCr20Co18Ti	2.4631
	Nickel- und Kobaltlegierungen	< 1300 N/mm2	2.4634	NiCo20Cr15MoAlTi	2.4654
	Hochwarmfeste Legierungen	< 1300 N/mm2		Hardox 400	1.4939
	Nickel-Kobalt-(Chrom-)legierungen	< 1400 N/mm2	2.4806	SG-NiCr20Nb, Inconel 82	2.4851
	Reintitan	< 900 N/mm2	3.7025	Ti99,8	3.7034
	Titanlegierungen	< 700 N/mm2	3.7114	TiAl5Sn2	3.7174
H	Titanlegierungen	< 1200 N/mm2	3.7164	TiAl5V4	3.7144
	Stahl gehärtet	< 45 HRc			
		46-55HRc			
		56-60 HRc			
	61-65 HRc				
	65-70 HRc				

Vorschub f:

Einstechen: 0,01 - 0,03 mm/U

Kopierendrehen: 0,03 - 0,10 mm/U

Axialstechen: 0,02 - 0,06 mm/U

feed f:

groove: 0,01-0,03 mm/Rev.

copy turning: 0,03 - 0,10 mm/Rev.

axial groove: 0,02 - 0,06 mm/Rev.

MINICUT

Bohrungsbearbeitung

grooving, boring and profiling

Technische Hinweise

Schnittdaten

Technical instructions,
cutting data



Werkstoffbezeichnung	Werkstoff-Nr	Werkstoffbezeichnung	Vc AL41F (m/min.)
St52-3	1.0060	St60-2	80-200
45S20	1.0757	46SPb2	80-200
17Mn4	1.1141	C15E (CK15)	80-200
13Cr3 (EC60)	1.5919	15CrNi6	80-160
Ck45	1.0535	C55	80-140
Ck60	1.0540	C50	80-160
28Cr4	1.7225	42CrMo4	80-160
34Cr4	1.3565	48CrMo4	80-150
GS-20NiCrMo3 7	1.6582	GS-34 CrNiMo 6	80-200
34AlMo5	1.8509	41CrAlMo7	70-140
39CrMoV19 3	1.8550	34 CrAlNi 7	70-140
X192CrMo17	1.3520	100 CrMn 6 (W4)	70-140
55Cr3	1.7701	51CrMoV4	
S 18-1-2-5	1.3294	PMH56-5-3-8; ASP30	
X155CrVMo12 1	1.2316	X38CrMo16; RAMAX	
X45NiCrMo4	1.2842	90MnCrV8	
X4CrMoS18	1.4107	GX8CrNi12	80-160
X105CrCoMo18 2	1.4016	X6Cr17	80-160
X50CrMoV15	1.4106	X2CrMoSi18-2-1	80-160
X30Cr13	1.4104	X14CrMoS17	20-85
X20CrNiSi25 4	1.4462	X2CrNiMoN22-5-3 (Duplex)	20-75
X6CrNiMoTi17 12 2	1.4449	X3CrNiMo18-12-3	20-65
X10NiCrAlTi32-21	1.4825	GX25CrNiSi18-9	20-65
GG25			30-180
GG45			30-150
GGG50			30-180
GGG80			30-120
GTW45			30-90
GTW65			20-80
GTS45			30-90
GTS70			20-80
Al99,9Mg0,5	3.0256	E-Al H	120-600
AlCuMg2	3.3315	AlMg1	120-600
GD-AlSi9Mg	3.2134	GD-AlSi5Cu1Mg	100-450
G-MgAl6	3.2525	S-AlSi12	70-300
G-AlSi25CuNiMg		G-AlSi21CuNiMg	60-150
SF-Cu	2.1522	CuSi2Mn	60-150
CuZn30	2.0321	CuZn37	100-180
CuSi3Mn		Ampco 8-16	90-180
		Ampco 18-26	80-180
		Ampco M-4	80-180
CuZn39Pb2 (Ms58)	2.0410	CuZn44Pb2	120-220
CuCrZr	2.1080	CuSn6Zn6	70-150
Makrolon, Novodur		Acrylglas, Polystyrol	80-180
Pertinax		Resopal	
CFK (Kohlefaserverstärkt)		AFK (Amidfaserverstärkt)	
MgAl6Zn1	3.5812	MgAl8Zn1	
R8650		Technograph15	
W-Cu80/20		W93NiFe (DENAL)	
TZC, TZM		MHC, ODS	
RNi8	1.3926	RNi12	30-80
Ni54	1.3921	Ni49	18-75
NiCu 30 Fe		Monel 400	18-75
NiMo16Cr16Ti		Hastelloy C-276	40-70
NiCr20TiAl		Nimonic 80	40-70
NiCr19Co14Mo4Ti		Waspaloy	40-70
X12CrNiMo12	1.4980	X6NiCrTiMoVB25-15-2	40-70
NiCr23Fe, Inconel 601	2.4667	SG-NiCr19NbMoTi	40-70
Ti99,7	3.7064	Ti99,5	40-70
TiAl6V6Sn2	3.7124	TiCu2	40-70
TiAl6Sn2Zr4Mo2	3.7154	TiAl6Zr5	40-70

Vorschub f:

Einstechen: 0,01 - 0,03 mm/U

Kopierendrehen: 0,03 - 0,10 mm/U

Axialstechen: 0,02 - 0,06 mm/U

feed f:

groove: 0,01-0,03 mm/Rev.

copy turning: 0,03 - 0,10mm/Rev.

axial groove: 0,02 - 0,06 mm/Rev.

MINICUT

Bohrungsbearbeitung

grooving, boring and profiling

Technische Hinweise

Schnittdaten

Technical instructions,
cutting data

	MATERIAL	STRENGTH (psi)	MATERIAL NUMBER	MATERIAL DESCRIPTION	ANSI
P	General Construction Steel	< 116030	1.0037	St37-2	A284
	Free-cutting steel	< 116030	1.0718	95MnPb28	12L13
	Non-Alloyed Steel	< 116030	1.0401	C15	1015
	Alloy Steel	< 145038	1.7331	16MnCr5 (EC80)	5120
	Compensation Steel Unalloyed	< 123282	1.0503	C45	1045
	Compensation Steel Unalloyed	< 145038	1.0601	C60	1060
	Alloy Steel	< 116030	1.5131	50MnSi4	
	Alloy Steel	< 188549	1.5755	31NiCr14	
	Cast Steel	< 123282	0.9650	G-X260Cr27	
	Nitriding Steel	< 145038	1.8504	34CrAl6	
	Nitriding Steel	< 174045	1.8515	31CrMo12	
	Bearing Steel	< 174045	1.3505	100Cr6 (W3)	52100
	Bearing Steel	< 174045	1.5026	55Si7	-
	High Speed Steel	< 188549	1.3344	S 6-5-3	
	Tool Steel for Cold Work	< 188549	1.2312	40CrMnMoS8 6	
	Tool Steel for Warm Work	< 188549	1.2343	X38CrMoV 5 1	H11
M	Steel and cast steel rostfrei sulfurized	< 123282	1.4305	X8CrNiS18 9	303
	Stainless Steel, Ferritic	< 108778	1.4510	X3CrTi17	
	Stainless Steel, Martensitic	< 130534	1.4034	X46Cr13	-
	Non-rusting. Steel, Ferritic / Martensite	< 159542	1.4313	X3CrNi13-4	
	Non-rusting. Steel, Austenitic / Ferritic	< 123282	1.4460	X8CrNiMo27 5	S32900
	Stainless Steel, Austenitic	< 108778	1.4301	X5CrNi18-10	304
K	Heat Resistant	< 159542	1.4747	X80CrNiSi20	
	Gray Cast Iron with Lamellar Graphite	14504-50763	0.6010	GG10	CLASS20
	Gray Cast Iron with Lamellar Graphite	43511-145038	0.6030	GG30	CLASS45
	Ball Graphite Castings	43511-72519	0.7040	GGG40	60-40-18
	Ball Graphite Castings	79771-116030	0.7060	GGG60	-
	Malleable Cast Iron	50763-65367	0.8035	GTW35	-
	Malleable Cast Iron	72519-94274	0.8055	GTW55	-
	Malleable Cast Iron Black	50763-65267	0.8135	GTS35	32510
N	Malleable Cast Iron Black	72519-101526	0.8155	GTS55	50005
	Aluminum (unalloyed, low alloy)	< 50763	3.0255	Al99,5	1000
	Aluminum Alloys < 0,5%	< 72519	3.0515	AlMn1	
	Aluminum Alloys 0,5-10%	< 58015	3.2152	GD-AlSi6Cu4	
	Aluminum Alloys 10-15%	< 58015	3.2381	G-AlSi10Mg	-
	Aluminum Alloys > 15%	< 58015		G-AlSi17Cu4	
	Copper (unalloyed, low alloy)	< 50763	2.0060	E-Cu57	
	Copper Wrought Alloys	< 101526	2.0240	CuZn15	C23000
	Copper Special Alloys	< 200 HB	2.0916	CuAl5	
	Copper Special Alloys	< 300HB	2.0978	CuAl11Ni6Fe5	
	Copper Special Alloys	> 300 HB	2.1247	CuBe2F125	
	Brass Short-Spanning, Bronze, Gunmetal	< 87023	2.0360	CuZn40 (Ms60)	C28000
	Brass Long-Spanning	< 87023	2.0335	CuZn36 (Ms63)	C36000, C48200
	Thermoplastics			Delrin, Hostalen	
	Thermosets			Ferrozell, Bakelit	
	Fiber Reinforced Plastics			GFK (Glasfaserverstärkt)	
	Magnesium and Magnesium Alloys	< 123282	3.5200	M2, MgMn2	
	Graphite			C8000, R8500X	
	Tungsten and Tungsten Alloys			W-NiFe (Densimet W)	
	Molybdenum and Molybdenum Alloys			Mo , Mo-50Re	
S	Pure Nickel		1.3911	RNi24	
	Nickel Alloys		1.3912	Ni36 (Invar)	
	Nickel Alloys	< 123282	2.4360	S-NiCu 30 Fe	
	Nickel-Chromium Alloy		2.4886	SG-NiMo16Cr16W	
	Nickel and Cobalt Alloys	< 188549	2.4632	NiCr20Co18Ti	
	Nickel and Cobalt Alloys	< 188549	2.4634	NiCo20Cr15MoAlTi	
	High-Temperature Resistant Alloys	< 188549		Hardox 400	
	Nickel-Cobalt-(Chrom-) Alloys	< 203053	2.4806	SG-NiCr20Nb, Inconel 82	
	Pure Titanium	< 130534	3.7025	Ti99,8	
	Titanium Alloys	< 101526	3.7114	TiAl5Sn2	-
	Titanium Alloys	< 174045	3.7164	TiAl5V4	
H	Hardened Steel	< 45 HRC			
		46-55HRC			
		56-60 HRC			
		61-65 HRC			
	65-70 HRC				

Data on this page is for reference and planning only. Materials and processes should be tested in your environment to achieve desired results.

feed f:

groove: 0.0004 - 0.0012 in/Rev.

copy turning: 0.0012 - 0.0039 in/Rev.

axial groove: 0.0008 - 0.0024 in/Rev.

MINICUT

Bohrungsbearbeitung

grooving, boring and profiling

Technische Hinweise

Schnittdaten

Technical instructions,
cutting data



MATERIAL NUMBER	MATERIAL DESCRIPTION	ANSI	MATERIAL NUMBER	MATERIAL DESCRIPTION	ANSI	AL41F (SFM)
1.0570	St52-3		1.0060	St60-2	A572	262-656
1.0727	45S20		1.0757	46SPb2		262-656
1.0481	17Mn4		1.1141	C15E (CK15)	1015	262-656
1.7015	13Cr3 (EC60)		1.5919	15CrNi6	3115	262-525
1.1191	Ck45	1045	1.0535	C55	1055	262-459
1.1221	Ck60	1060	1.0540	C50		262-525
1.7030	28Cr4		1.7225	42CrMo4	4140	262-525
1.7033	34Cr4	5132	1.3565	48CrMo4		262-492
1.6750	GS-20NiCrMo3 7		1.6582	GS-34 CrNiMo 6	4337	262-656
1.8507	34AlMo5		1.8509	41CrAlMo7	A355	230-459
1.8523	39CrMoV19 3		1.8550	34 CrAlNi 7		230-459
1.3543	X192CrMo17		1.3520	100 CrMn 6 (W4)		230-459
1.7176	55Cr3	5155	1.7701	51CrMoV4		
1.3255	S 18-1-2-5	1015	1.3294	PMHS6-5-3-8; ASP30		
1.2379	X155CrVMo12 1	D2	1.2316	X38CrMo16; RAMAX		
1.2767	X45NiCrMo4		1.2842	90MnCrV8	02	
1.4105	X4CrMoS18	430F	1.4107	GX8CrNi12		262-525
1.4528	X105CrCoMo18 2		1.4016	X6Cr17	430	262-525
1.4116	X50CrMoV15		1.4106	X2CrMoSiS18-2-1		262-525
1.4028	X30Cr13	420F	1.4104	X14CrMoS17	430 F	66-279
1.4821	X20CrNiSi25 4		1.4462	X2CrNiMoN22-5-3 (Duplex)	UNS31803	66-246
1.4571	X6CrNiMoTi17 12 2	316 Ti	1.4449	X3CrNiMo18-12-3	317	66-213
1.4876	X10NiCrAlTi32-21	B163	1.4825	GX25CrNiSi18-9		66-213
0.6025	GG25	A48-40 B				98-591
0.6045	GG45					98-492
0.7050	GGG50	65-45-12				98-591
0.7080	GGG80	120-90-02				98-394
0.8045	GTW45					98-295
0.8065	GTW65					66-262
0.8145	GTS45					98-295
0.8170	GTS70					66-262
3.3308	Al99,9Mg0,5		3.0256	E-Al H		394-1968
3.1355	AlCuMg2	2024	3.3315	AlMg1		394-1968
3.2373	GD-AlSi9Mg		3.2134	GD-AlSi5Cu1Mg		328-1476
3.5562	G-MgAl6		3.2525	S-AlSi12		230-984
	G-AlSi25CuNiMg			G-AlSi21CuNiMg		197-492
2.0090	SF-Cu		2.1522	CuSi2Mn		197-492
2.0265	CuZn30		2.0321	CuZn37		328-591
2.1525	CuSi3Mn			Ampco 8-16		295-591
				Ampco18-26		262-591
				Ampco M-4		262-591
2.0380	CuZn39Pb2 (Ms58)		2.0410	CuZn44Pb2		394-722
2.1293	CuCrZr		2.1080	CuSn6Zn6		230-492
	Makrolon, Novodur			Acrylglas, Polystyrol		262-591
	Pertinax			Resopal		
	CFK (Kohlefaserverstärkt)			AFK (Amidfaserverstärkt)		
3.5612	MgAl6Zn1		3.5812	MgAl8Zn1		
	R8650			Technograph15		
	W-Cu80/20			W93NiFe (DENAL)		
	TZC, TZM			MHC , ODS		
1.3927	RNi8		1.3926	RNi12		98-262
1.3924	Ni54		1.3921	Ni49		59-246
	NiCu 30 Fe			Monel 400		59-246
2.4610	NiMo16Cr16Ti			Hastelloy C-276		131-230
2.4631	NiCr20TiAl			Nimonic 80		131-230
2.4654	NiCr19Co14Mo4Ti			Waspaloy		131-230
1.4939	X12CrNiMo12	904L	1.4980	X6NiCrTiMoVB25-15-2		131-230
2.4851	NiCr23Fe, Inconel 601		2.4667	SG-NiCr19NbMoTi		131-230
3.7034	Ti99,7		3.7064	Ti99,5		131-230
3.7174	TiAl6V6Sn2		3.7124	TiCu2		131-230
3.7144	TiAl6Sn2Zr4Mo2		3.7154	TiAl6Zr5		131-230

Data on this page is for reference and planning only. Materials and processes should be tested in your environment to achieve desired results.

feed f:

groove: 0.0004 - 0.0012 in/Rev.

copy turning: 0.0012 - 0.0039 in/Rev.

axial groove: 0.0008 - 0.0024 in/Rev.

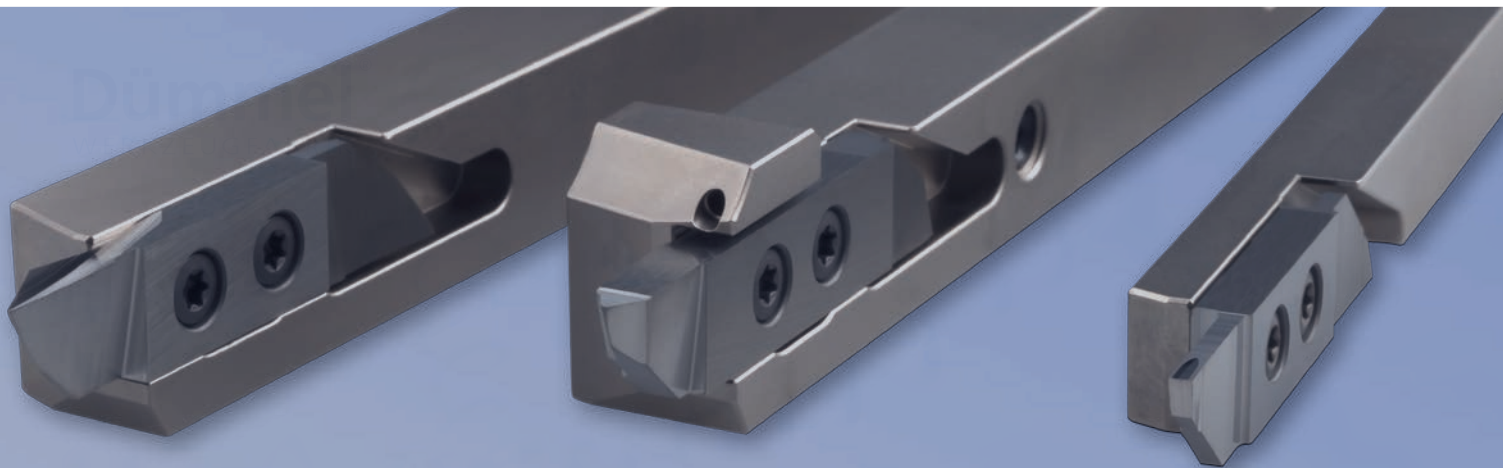

 **Dümmel**[®]
WERKZEUGFABRIK

SWISSLINE



**Miniaturaußenbearbeitung,
zweischneidig**

**miniature external machining,
two cutting edges**

SWISSLINE

Miniatúraußenbearbeitung,
zweischneidig

miniature external machining,
two-cutting edges

Übersicht

summary

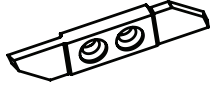

Allgemeine Beschreibung

general instructions

... 187

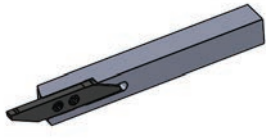

Klemmhalter

toolholder

**Maße
dimensions**

**Seite
page**

Typ R/L HW10

Klemmhalter

toolholder

... 188

Typ R/L HW15

Klemmhalter
mit Innenkühlung

toolholder
with internal cooling

... 189

Typ R/L HW20

Klemmhalter,
abgesetzte Version

toolholder,
offset version

... 190



**Schneidplattenhalter
für Rückseitenbearbeitung
auf Langdrehautomaten**

**toolholder
for rear end machining
on Swiss type lathes**

**Maße
dimensions**

**Seite
page**

Typ UMHV

Schneidplattenhalter

toolholder

... 191

SWISSLINE

Miniaturaußenbearbeitung,
zweischneidig

miniature external machining,
two-cutting edges

Übersicht

summary

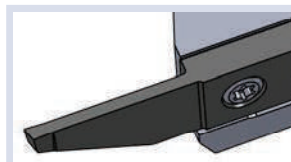

Wendeschneidplatten
Abstechen

indexable inserts
parting off

Maße
dimensions

Seite
page

Typ R/L ZW10	Abstechen	parting off	t max. = 6 - 16 b = 0.8 - 3	... 192
Typ R/L ZW11	Abstechen, Schneide versetzt	parting off, offset cutting edge	t max. = 6 - 16 b = 0.8 - 3	... 193
Typ R/L ZW12	Abstechen mit Gegenspindel	parting off with counter spindle	t max. = 6 b = 0.8 / 1.2	... 194
Typ R/L ZW13	Abstechen mit Gegenspindel, Schneide versetzt	parting off with counter spindle, offset cutting edge	t max. = 6 b = 0.8 / 1.2	... 195
Typ R/L ZW14	Abstechen, mit Spanformer	parting off, with chip former	t max. = 8 - 16 b = 1.5 - 3	... 196
Typ R/L ZW15	Abstechen, Schneide versetzt, mit Spanformer	parting off, offset cutting edge, with chip former	t max. = 8 - 16 b = 1.5 - 3	... 197
Typ R/L ZW16	Abstechen, mit Spantreppe	parting off, with chip breaker	t max. = 8 - 16 b = 1.5 - 3	... 198
Typ R/L ZW17	Abstechen, Schneide versetzt, mit Spantreppe	parting off, offset cutting edge, with chip breaker	t max. = 8 - 16 b = 1.5 - 3	... 199
Typ R/L ZW18	Abstechen unter 0°, mit Spanformer	parting off with 0°, with chipformer	t max. = 10 - 16 b = 1.5 - 3	... 200
Typ R/L ZW19	Abstechen unter 0°, mit Spantreppe	parting off with 0°, with chip breaker	t max. = 10 - 16 b = 1.5 - 3	... 201
Typ R/L ZW1A	Abstechen, mit gesintertem Spanformer	parting off, with sintered chipformer	t max. = 10 b = 2	... 202
Typ R/L ZW1B	Abstechen, Schneide versetzt, mit gesintertem Spanformer	parting off, offset cutting edge, with sintered chipformer	t max. = 10 b = 2	... 203
Typ R/L ZW1C	Abstechen unter 0°, mit gesintertem Spanformer	parting off with 0°, with sintered chip former	t max. = 10 b = 2	... 204



SWISSLINE

Miniatúraußenbearbeitung,
zweischneidig

miniature external machining,
two-cutting edges

Übersicht

summary

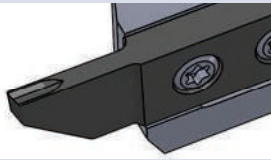

Wendeschneidplatten Drehen und Abstechen

indexable inserts turning and parting off

Maße dimensions

Seite page

Typ R/L ZW20	Drehen und Abstechen, Wipergeometrie	turning and parting off, wiper geometry	t max. = 10 b = 2	... 205
Typ R/L ZW21	Drehen und Abstechen, Schneide versetzt, Wipergeometrie	turning and parting off, offset cutting edge, wiper geometry	t max. = 10 b = 2	... 206
Typ R/L ZW22	Drehen und Abstechen, mit Spanformer, Wipergeometrie	turning and parting off, with chipformer, wiper geometry	t max. = 10 b = 2	... 207
Typ R/L ZW23	Drehen und Abstechen, Schneide versetzt, mit Spanformer, Wipergeometrie	turning and parting off, offset cutting edge, with chipformer, wiper geometry	t max. = 10 b = 2	... 208



Wendeschneidplatten Drehen

indexable inserts turning

Maße dimensions

Seite page

Typ R/L ZW30	Vornedrehen	turning in front	t max. = 8 b = 3.4	... 209
Typ R/L ZW31	Vornedrehen, mit Spanformer, Wipergeometrie	turning in front, with chipformer, wiper geometry	t max. = 8 b = 3.4	... 210
Typ R/L ZW40	Kopierdrehen vorne, Schneide versetzt, mit Spanformer	profiling in front, offset cutting edge, with chipformer	t max. = 11 b = 3.2	... 211
Typ R/L ZW41	Kopierdrehen hinten, mit Spanformer	profiling at the back, with chipformer	t max. = 11 b = 3.2	... 212
Typ R/L ZW50	Hintendrehen, Wipergeometrie	turning at the back, wiper geometry	t max. = 6 - 8 b = 0.8 - 1.8	... 213
Typ R/L ZW51	Kopierdrehen hinten, mit Spanformer, Wipergeometrie	profiling at the back, with chip former, wiper geometry	t max. = 6 b = 0.5	... 214
Typ R/L ZW52	Hintendrehen, mit Spantreppe	turning at the back, with chip breaker	t max. = 4.5 b = 0.8	... 215
Typ R/L ZW60	Einstechen und Längsdrehen	grooving and turning	t max. = 2.5 - 6 b = 1 - 3	... 216
Typ R/L ZW61	Einstechen und Längsdrehen, mit Spantreppe	grooving and turning, with chip breaker	t max. = 2.5 - 6 b = 0.8 - 3	... 217



SWISSLINE

Miniatúraußenbearbeitung,
zweischneidig

miniature external machining,
two-cutting edges

Übersicht

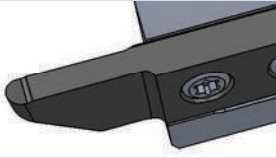
summary

	Wendeschneidplatten Stechdrehen	indexable inserts grooving	Maße dimensions	Seite page
Typ R/L ZW70	Stechdrehen, Vollradius mit Spantreppe	grooving, full radius with chip breaker	t max. = 2 - 16 b = 0.5 - 3.0	... 218
	Wendeschneidplatten Gewindedrehen	indexable inserts threading	Maße dimensions	Seite page
Typ R/L ZW90	Gewindedrehen, Vollprofil, 60°	threading, full profile, 60°	M1 - M4.5 P = 0.25 - 0.75	... 219
Typ R/L ZW90	Gewindedrehen, Vollprofil, 60°	threading, full profile, 60°	M5 - M27 P = 0.8 - 3.0	... 220
Typ R/L ZW94	Gewindedrehen, Teilprofil, 55° / 60°	threading, partial profile, 55° / 60°	P = 0.25 - 2.0	... 221

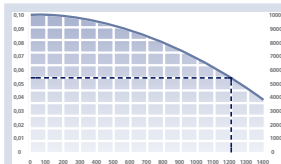

Technische Hinweise

Technical Instructions

**Seite
page**

Beschreibung der
Schneidenausführungen

Description of the cutting types

... 222

Allgemeine Informationen zum
Gewindeschneiden

General informations about threading

... 223

Hartmetallsorten und Beschichtungen

carbide grade and coatings

... 225

Schnittdaten

cutting data

... 227

SWISSLINE

Miniatúraußenbearbeitung,
zweischneidig

miniature external machining,
two-cutting edges

Allgemeine Beschreibung

general instruction

Swissline

Unser Programm Swissline bietet ein Stech-Drehwerkzeug für Langdrehautomaten mit einem Stangendurchlass von maximal 32 mm. Schneiden für das Abstechen, Stechdrehen, Überdrehen, Kopierdrehen und Gewindeschneiden sind im Standard verfügbar. Ein breites Angebot von geschliffenen Haltern mit veredelter Oberfläche und Schaftquerschnitten von 8 - 25 mm runden das Programm ab.

Swissline

A turn and parting off tool system for Swiss type lathes up to \varnothing 32 mm. Inserts for parting off, grooving, turning, profiling and threading are in standard available. A wide range of refined tool holders and shank sizes between 8 - 25 mm completes our product line.

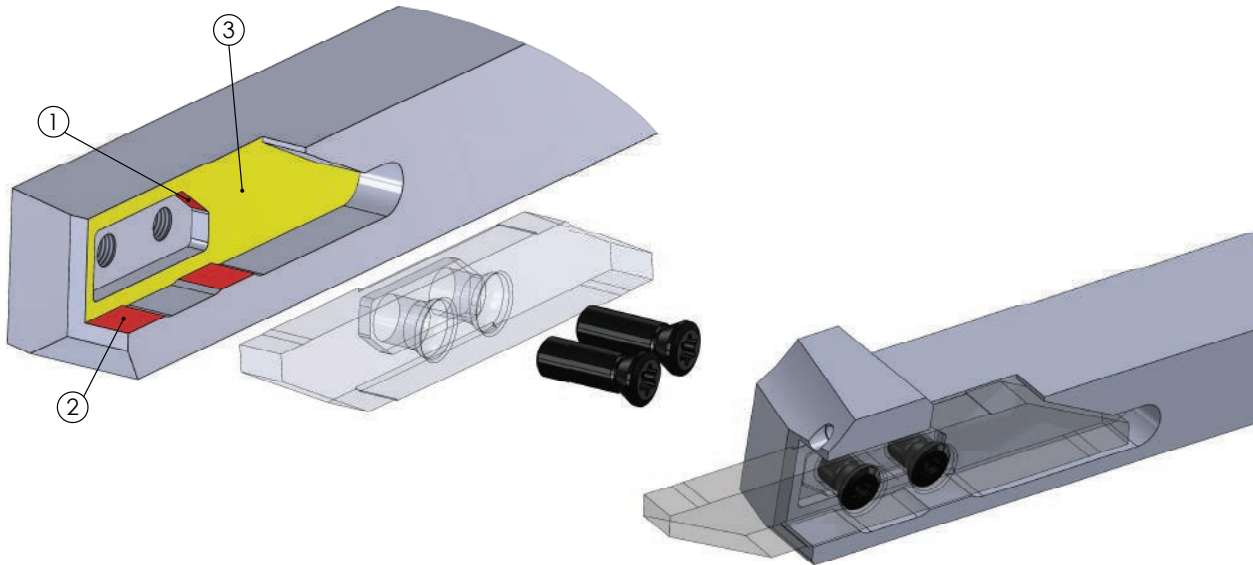

Vorteile:	Advantages:
Große Auswahl an Schneidgeometrien mit speziellen Spanleitstufen für die Bearbeitung	Large selection of insert geometries with different chip breaker geometries
Exakte Positionierung durch 2 Schrauben mit Anschlag (1 + 2) für die axiale Ausrichtung	Special chip breaker design for machining of small- to mid-sized work pieces
Die große Auflagefläche garantiert eine senkrechte Ausrichtung (3)	Perpendicularity guaranteed by two fixing screws, large support face and a genuine stop face for axial positioning
Schnittkräfte werden direkt von der Wendplatte auf den Halter übertragen, sodass keine Abscherkräfte auf die Schrauben wirken	The cutting forces are transferred directly from the insert to the holder; the screws are therefore not exposed to shear stress
Wendeschneidplatten bedingt nachschleifbar	limited regrinding possibility
Bei Schneidenbruch ist die zweite intakte Schneide trotzdem einsetzbar	If first cutting edge has crashed the second is still usable

SWISSLINE

Miniaturaußenbearbeitung,
zweischneidig

miniature external machining,
two-cutting edges

Typ HW10

Klemmhalter

toolholder

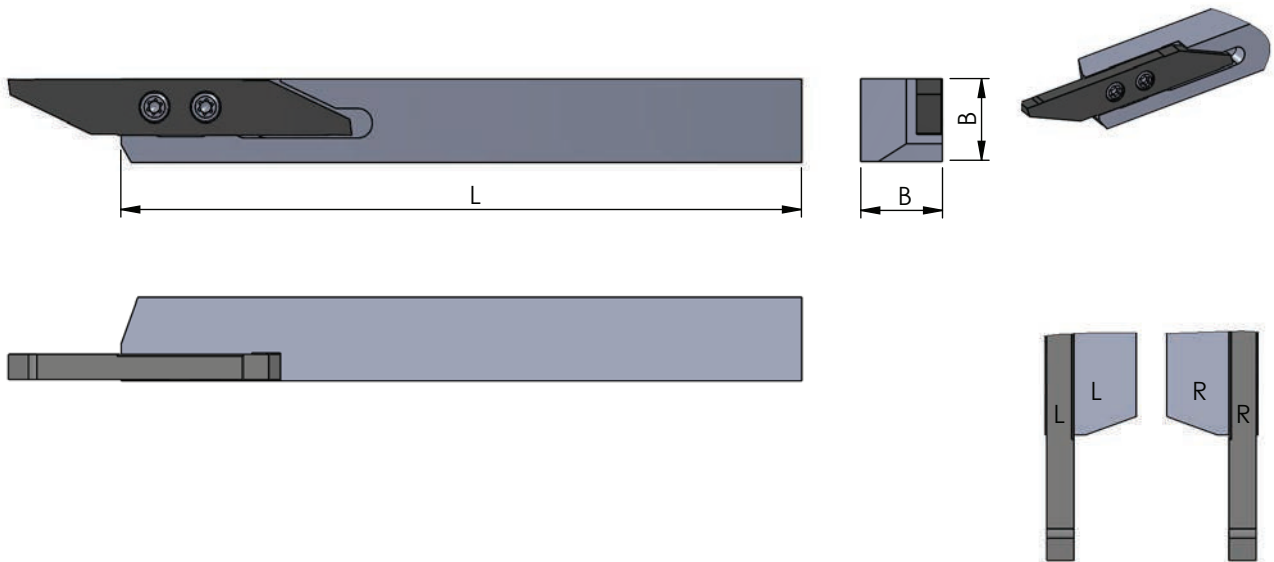

Rechts (R): wie gezeichnet
Links (L): spiegelbildlich

Rechte Schneidpl. in rechtem Halter
Linke Schneidpl. in linkem Halter

Abmessungen in mm

righthand version (R): as shown
lefthand version (L): mirror image

use RH insert in RH tool holder and
LH insert in LH tool holder

dimensions in mm



Bestellnummer part number	B	B (Zoll / inch)	L	Spannschraub screw	Schraubenschlüssel wrench	Anzugs- drehmoment torque	für Schneidplatte for insert
R/L HW10.0808080	8		80	M3/7-SL	Torx T8	1.2 Nm	R/L ZW...
R/L HW10.0808100	8		100				
R/L HW10.1010080	10		80				
R/L HW10.1010100	10		100				
R/L HW10.1212100	12		100				
R/L HW10.1616125	16		125				
R/L HW10.2020125	20		125				
R/L HW10.2525150	25		150	M3/9-SL	Torx T8	1.2 Nm	
R/L HW10.Z0909080	9.525	3/8"	80				
R/L HW10.Z0909100	9.525	3/8"	100				
R/L HW10.Z1212100	12.7	1/2"	100				
R/L HW10.Z1515125	15.875	5/8"	125				
R/L HW10.Z1919125	19.05	3/4"	125				

Bestellbeispiel:
für rechte Ausführung
RHW10.0808080

order-example:
righthand version
RHW10.0808080

SWISSLINE

Miniatúraußenbearbeitung,
zweischneidig

miniature external machining,
two-cutting edges

Typ HW15

Klemmhalter
mit Innenkühlung

toolholder
with internal cooling

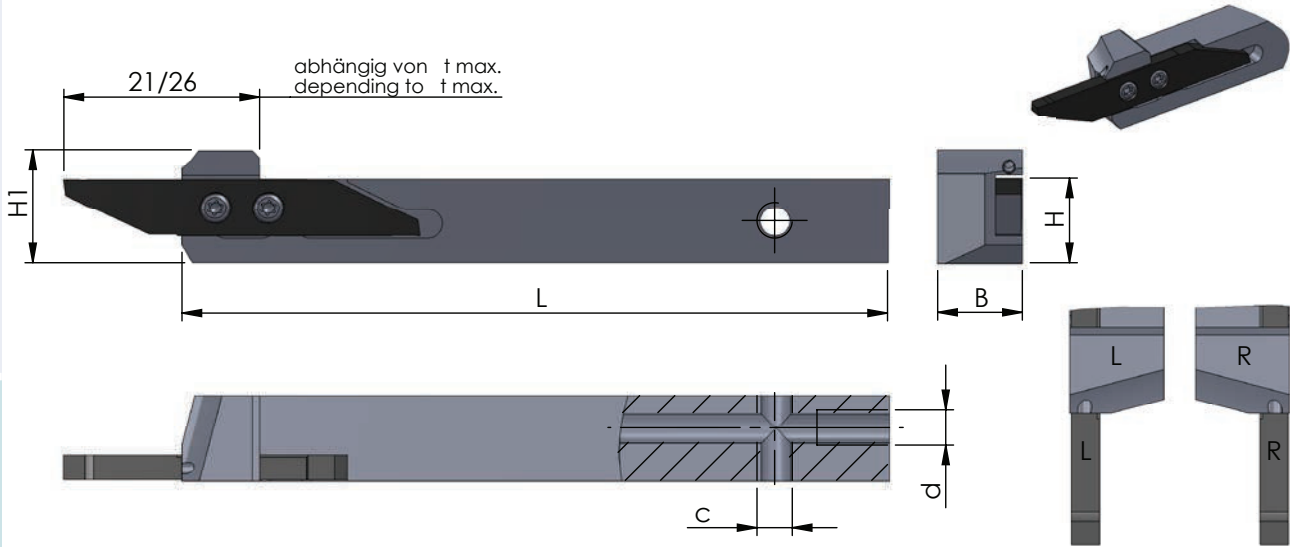

Rechts (R): wie gezeichnet
Links (L): spiegelbildlich

Rechte Schneidpl. in rechtem Halter
Linke Schneidpl. in linkem Halter

Abmessungen in mm

righthand version (R): as shown
lefthand version (L): mirror image

use RH insert in RH tool holder and
LH insert in LH tool holder

dimensions in mm

Bestellnummer part number	B	B (Zoll / inch)	H	H (Zoll / inch)	L	H1	c	d	Spannschraub screw	Schraubenschlüssel wrench	Anzugs- drehmoment torque	für Schneidplatte for insert
R/L HW15.1208100	12		8		100	12.2	M5	M5	M3/9-SL	Torx T8	1.2 Nm	R/L ZW. ...
R/L HW15.1210100	12		10		100	14	M5	M5				
R/L HW15.1212100	12		12		100	16	M5	M5				
R/L HW15.1616125	16		16		125	20	M5	G1/8"				
R/L HW15.2020125	20		20		125	24	M5	G1/8"				
R/L HW15.2525125	25		25		125	29	M5	G1/8"				
R/L HW15.Z0909100	9.525	3/8"	9.525	3/8"	100	13.5	M5	M5				
R/L HW15.Z1212100	12.7	1/2"	12.7	1/2"	100	16.7	M5	M5				
R/L HW15.Z1515125	15.875	5/8"	15.875	5/8"	125	19.9	M5	G1/8"				
R/L HW15.Z1919125	19.05	3/4"	19.05	3/4"	125	23	M5	G1/8"				

Lieferumfang:
Halter ohne Kühlmittelanschluss

Bestellbeispiel:
für rechte Ausführung
RHW15.1208100

Scope of delivery:
Holder without coolant connector

order-example:
righthand version
RHW15.1208100

SWISSLINE

Miniaturaußenbearbeitung,
zweischneidig

miniature external machining,
two-cutting edges

Typ HW20

Klemmhalter,
abgesetzte Version

toolholder,
offset version

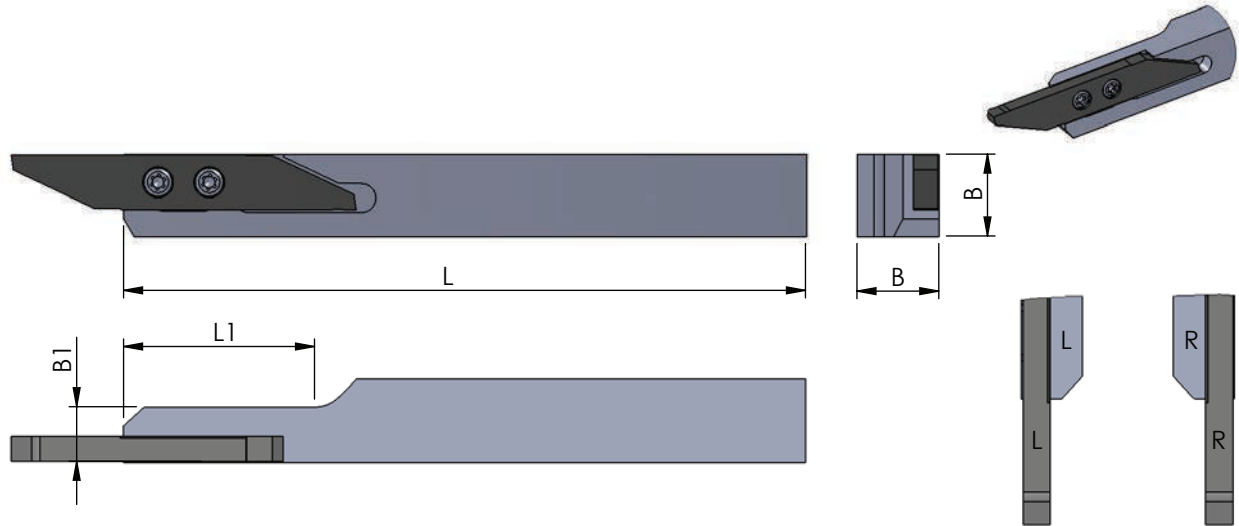

Rechts (R): wie gezeichnet
Links (L): spiegelbildlich

Rechte Schneidpl. in rechtem Halter
Linke Schneidpl. in linkem Halter

Abmessungen in mm

righthand version (R): as shown
lefthand version (L): mirror image

use RH insert in RH tool holder and
LH insert in LH tool holder

dimensions in mm

Bestellnummer part number	B	B (Zoll / inch)	L	L1	B1	Spannschraub screw	Schraubenschlüssel wrench	Anzugs- drehmoment torque	für Schneidplatte for insert
R/L HW20.1010080	10		80	28	8	M3/7-SL	Torx T8	1.2 Nm	R/L ZW. ...
R/L HW20.1010100	10		100	28	8				
R/L HW20.1212100	12		100	28	8				
R/L HW20.1616125	16		125	28	8				
R/L HW20.Z0909080	9.525	3/8"	80	28	8				
R/L HW20.Z0909100	9.525	3/8"	100	28	8				
R/L HW20.Z1212100	12.7	1/2"	100	28	8				
R/L HW20.Z1515125	15.875	5/8"	125	28	8				

Bestellbeispiel:
für rechte Ausführung
RHW20.1010080

order-example:
righthand version
RHW20.1010080

SWISSLINE

Miniaturaußenbearbeitung,
zweischneidig

miniature external machining,
two-cutting edges

Typ UMHV

Schneidplattenhalter
für Rückseitenbearbeitung
auf Langdrehautomaten

toolholder
for rear end machining
on Swiss type lathes

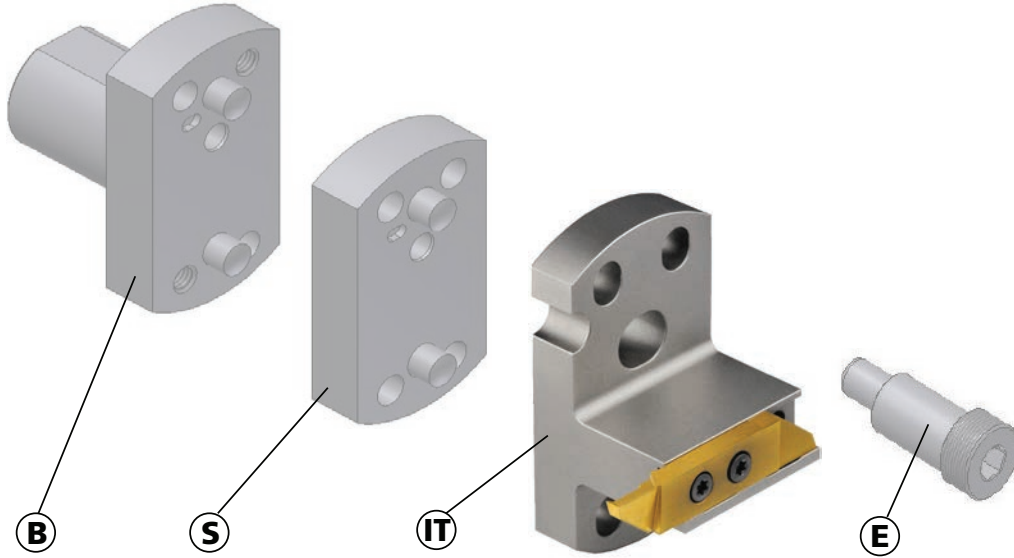

Klemmhalter für rechte und linke
Schneideinsätze einsetzbar

toolholder for right and left
inserts usable

Abmessungen in mm

dimensions in mm

Bestellnummer part number	Position	Bezeichnung description	Schneideinsatz insert
UMHV-I0201SWISSRL	IT	Schneidplattenhalter / toolholder	RL ZW...
auf Anfrage / on request	B	Grundhalter / basic toolholder	
auf Anfrage / on request	S	Zwischenplatte / spacer	
auf Anfrage / on request	E	Excenter / excenter	

Bestellbeispiel:
UMHV-I0201SWISSRL

order-example:
UMHV-I0201SWISSRL

SWISSLINE

Miniatöraußenbearbeitung,
zweischneidig

miniature external machining,
two-cutting edges

Typ ZW10

Wendeschneidplatten,
zum Abstechen

indexable inserts
for parting off

Stechtiefe t max. = 6 - 16 mm
Stechbreite b = 0.8 - 3.0 mm

depth of groove t max. = 6 - 16 mm
width of groove b = 0.8 - 3.0 mm

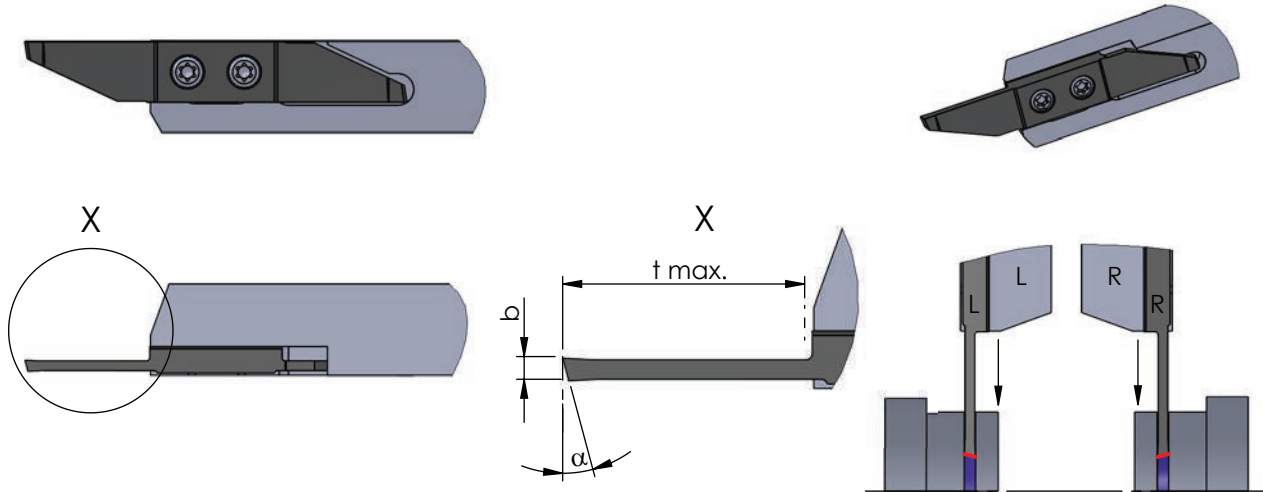

Rechts (R): wie gezeichnet
Links (L): spiegelbildlich

Rechte Schneidpl. in rechtem Halter
Linke Schneidpl. in linkem Halter

Abmessungen in mm

righthand version (R): as shown
lefthand version (L): mirror image

use RH insert in RH tool holder and
LH insert in LH tool holder

dimensions in mm

Bestellnummer part number	b	t max.	α					Klemmhalter Typ toolholder type
				K10F	CN45F	AL41F	P18C	
R/L ZW10.08061500	0.8	6	15°	●			●	R/L HW10... R/L HW15... R/L HW20...
R/L ZW10.08101500	0.8	10	15°	●			●	
R/L ZW10.10061500	1.0	6	15°	●			●	
R/L ZW10.10131500	1.0	13	15°	●			●	
R/L ZW10.12061500	1.2	6	15°	●			●	
R/L ZW10.15081500	1.5	8	15°	●			●	
R/L ZW10.15161500	1.5	16	15°	●			●	
R/L ZW10.18081500	1.8	8	15°	●			●	
R/L ZW10.20101500	2.0	10	15°	●			●	
R/L ZW10.20161500	2.0	16	15°	●			●	
R/L ZW10.25131500	2.5	13	15°	●			●	
R/L ZW10.25161500	2.5	16	15°	●			●	
R/L ZW10.30161500	3.0	16	15°	●			●	

Weitere HM Sorten können Sie in der Sorten-
übersicht im Kapitel "Technische Hinweise" und
der Preisliste finden.

Bestellbeispiel:
für rechte Ausführung und Sorte
RZW10.08061500/P18C

More carbide grades you can find in the grades
summary in the chapter "technical instructions"
and in the price list.

order-example:
righthand version and grade
RZW10.08061500/P18C

SWISSLINE

Miniatúraußenbearbeitung,
zweischneidig

miniature external machining,
two-cutting edges

Typ ZW11

Wendeschneidplatten,
zum Abstechen,
Schneide versetzt

indexable inserts,
for parting off,
offset cutting edge

Stechtiefe t max. = 6 - 16 mm
Stechbreite b = 0.8 - 3.0 mm

depth of groove t max. = 6 - 16 mm
width of groove b = 0.8 - 3.0 mm

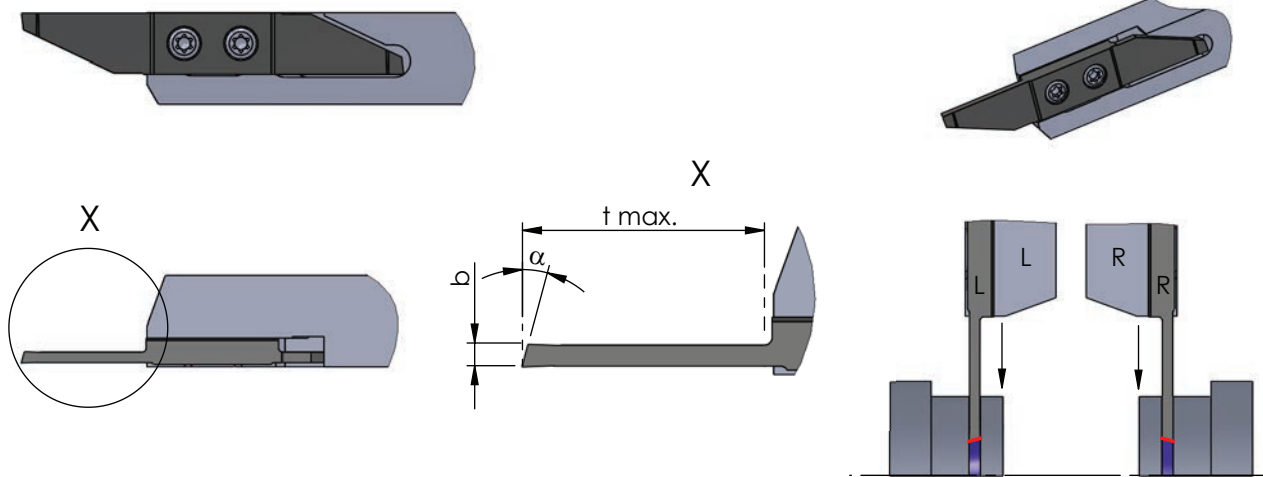

Rechts (R): wie gezeichnet
Links (L): spiegelbildlich

Rechte Schneidpl. in rechtem Halter
Linke Schneidpl. in linkem Halter

Abmessungen in mm

righthand version (R): as shown
lefthand version (L): mirror image

use RH insert in RH tool holder and
LH insert in LH tool holder

dimensions in mm

Bestellnummer part number	b	t max.	α	Klemmhalter Typ toolholder type			
				K10F	CN45F	AL41F	P18C
R/L ZW11.08061500	0.8	6	15°	●			●
R/L ZW11.08101500	0.8	10	15°	●			●
R/L ZW11.10061500	1.0	6	15°	●			●
R/L ZW11.10131500	1.0	13	15°	●			●
R/L ZW11.12061500	1.2	6	15°	●			●
R/L ZW11.15081500	1.5	8	15°	●			●
R/L ZW11.15161500	1.5	16	15°	●			●
R/L ZW11.18081500	1.8	8	15°	●			●
R/L ZW11.20101500	2.0	10	15°	●			●
R/L ZW11.20161500	2.0	16	15°	●			●
R/L ZW11.25131500	2.5	13	15°	●			●
R/L ZW11.25161500	2.5	16	15°	●			●
R/L ZW11.30161500	3.0	16	15°	●			●

Weitere HM Sorten können Sie in der Sorten-
übersicht im Kapitel "Technische Hinweise" und
der Preisliste finden.

Bestellbeispiel:
für rechte Ausführung und Sorte
RZW11.08061500/P18C

More carbide grades you can find in the grades
summary in the chapter "technical instructions"
and in the price list.

order-example:
righthand version and grade
RZW11.08061500/P18C

SWISSLINE

Miniatöraußenbearbeitung,
zweischneidig

miniature external machining,
two-cutting edges

Typ ZW12

Wendeschneidplatten,
Abstechen mit Gegenspindel

indexable inserts,
parting off with counter spindle

Stechtiefe t max. = 6 mm
Stechbreite b = 0.8 / 1.2 mm

depth of groove t max. = 6 mm
width of groove b = 0.8 / 1.2 mm

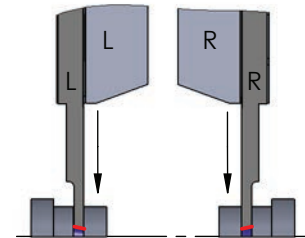
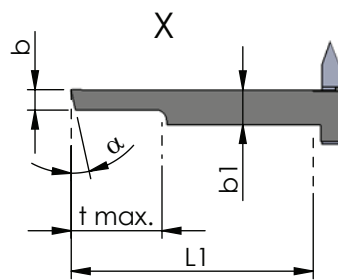
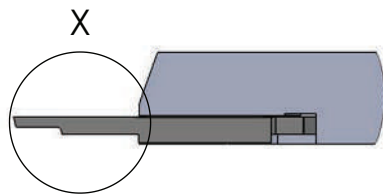
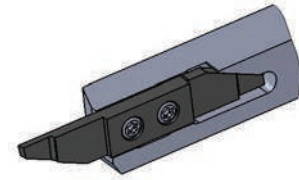

Rechts (R): wie gezeichnet
Links (L): spiegelbildlich

Rechte Schneidpl. in rechtem Halter
Linke Schneidpl. in linkem Halter

Abmessungen in mm

righthand version (R): as shown
lefthand version (L): mirror image

use RH insert in RH tool holder and
LH insert in LH tool holder

dimensions in mm



Bestellnummer part number	b	t max.	α	L1	b1	Klemmhalter Typ toolholder type				
						K10F	CN45F	AL41F	P18C	
R/L ZW12.08061500	0.8	6	15°	16	2.0	●		●		R/L HW10... R/L HW15... R/L HW20...
R/L ZW12.12061500	1.2	6	15°	16	2.4	●		●		

Weitere HM Sorten können Sie in der Sorten-
übersicht im Kapitel "Technische Hinweise" und
der Preisliste finden.

Bestellbeispiel:
für rechte Ausführung und Sorte
RZW12.08061500/P18C

More carbide grades you can find in the grades
summary in the chapter "technical instructions"
and in the price list.

order-example:
righthand version and grade
RZW12.08061500/P18C

SWISSLINE

Miniatúraußenbearbeitung,
zweischneidig

miniature external machining,
two-cutting edges

Typ ZW13

Wendeschneidplatten,
Abstechen mit Gegenspindel,
Schneide versetzt

indexable inserts,
parting off with counter spindle,
offset cutting edge

Stechtiefe t max. = 6 mm
Stechbreite b = 0.8 / 1.2 mm

depth of groove t max. = 6 mm
width of groove b = 0.8 / 1.2 mm

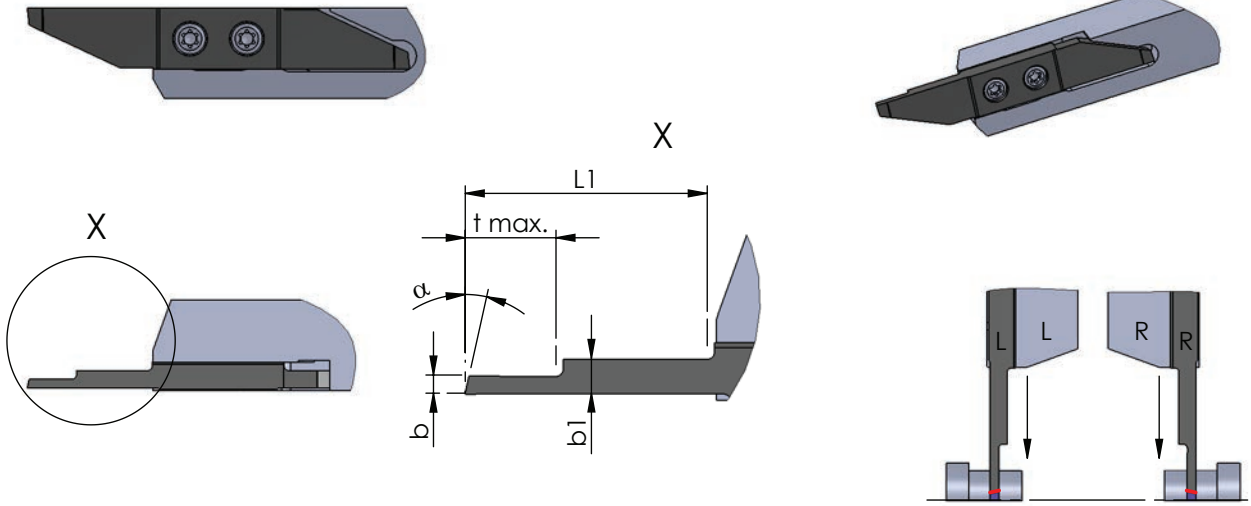

Rechts (R): wie gezeichnet
Links (L): spiegelbildlich

Rechte Schneidpl. in rechtem Halter
Linke Schneidpl. in linkem Halter

Abmessungen in mm

righthand version (R): as shown
lefthand version (L): mirror image

use RH insert in RH tool holder and
LH insert in LH tool holder

dimensions in mm

Bestellnummer part number	b	t max.	α	L1	b1	Klemmhalter Typ toolholder type				
						K10F	CN45F	AL41F	P18C	
R/L ZW13.08061500	0.8	6	15°	16	2.0	●		●		R/L HW10... R/L HW15... R/L HW20...
R/L ZW13.12061500	1.2	6	15°	16	2.4	●		●		

Weitere HM Sorten können Sie in der Sorten-
übersicht im Kapitel "Technische Hinweise" und
der Preisliste finden.

Bestellbeispiel:
für rechte Ausführung und Sorte
RZW13.08061500/P18C

More carbide grades you can find in the grades
summary in the chapter "technical instructions"
and in the price list.

order-example:
righthand version and grade
RZW13.08061500/P18C

SWISSLINE

Miniatúraußenbearbeitung,
zweischneidig

miniature external machining,
two-cutting edges

Typ ZW14

Wendeschneidplatten,
zum Abstechen,
mit Spanformer

indexable inserts,
for parting off,
with chip former

Stechtiefe t max. = 8 - 16 mm
Stechbreite b = 1.5 - 3 mm

depth of groove t max. = 8 - 16 mm
width of groove b = 1.5 - 3 mm

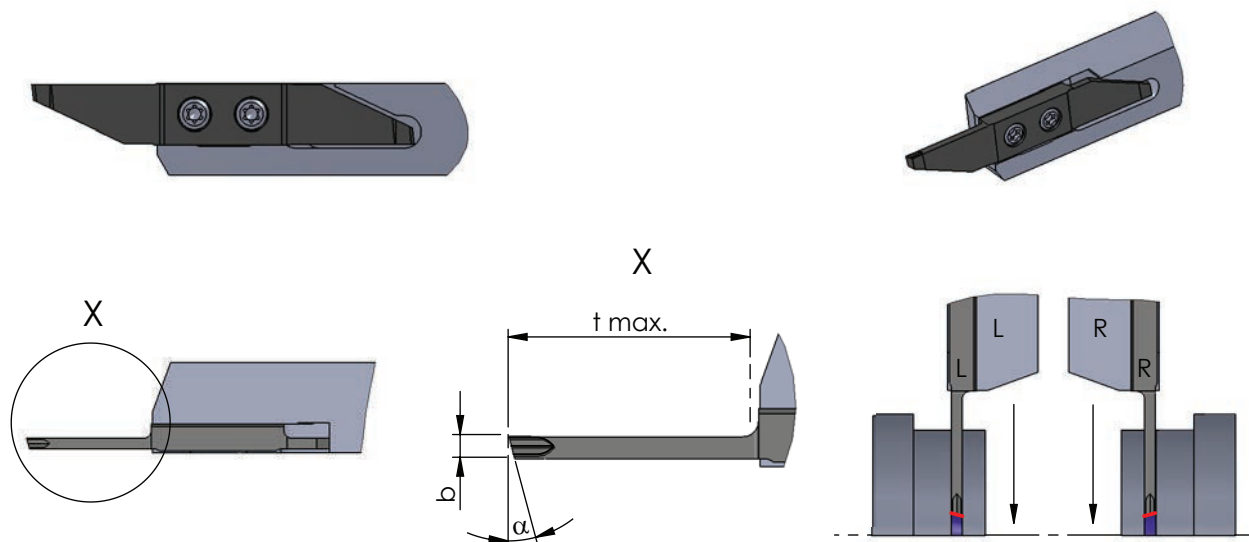

Rechts (R): wie gezeichnet
Links (L): spiegelbildlich

Rechte Schneidpl. in rechtem Halter
Linke Schneidpl. in linkem Halter

Abmessungen in mm

righthand version (R): as shown
lefthand version (L): mirror image

use RH insert in RH tool holder and
LH insert in LH tool holder

dimensions in mm

Bestellnummer part number	b	t max.	α	Klemmhalter Typ toolholder type			
				K10F	CN45F	AL41F	P18C
R/L ZW14.15081500	1.5	8	15°	●			●
R/L ZW14.15161500	1.5	16	15°	●			●
R/L ZW14.20101500	2.0	10	15°	●			●
R/L ZW14.20161500	2.0	16	15°	●			●
R/L ZW14.25131500	2.5	13	15°	●			●
R/L ZW14.25161500	2.5	16	15°	●			●
R/L ZW14.30161500	3.0	16	15°	●			●

Weitere HM Sorten können Sie in der Sorten-
übersicht im Kapitel "Technische Hinweise" und
der Preisliste finden.

Bestellbeispiel:
für rechte Ausführung und Sorte
RZW14.15081500/P18C

More carbide grades you can find in the grades
summary in the chapter "technical instructions"
and in the price list.

order-example:
righthand version and grade
RZW14.15081500/P18C

SWISSLINE

Miniatúraußenbearbeitung,
zweischneidig

miniature external machining,
two-cutting edges

Typ ZW15

Wendeschneidplatten,
zum Abstechen,
Schneide versetzt, mit Spanformer

indexable inserts,
for parting off,
offset cutting edge, with chip former

Stechtiefe t max. = 8 - 16 mm
Stechbreite b = 1.5 - 3 mm

depth of groove t max. = 8 - 16 mm
width of groove b = 1.5 - 3 mm

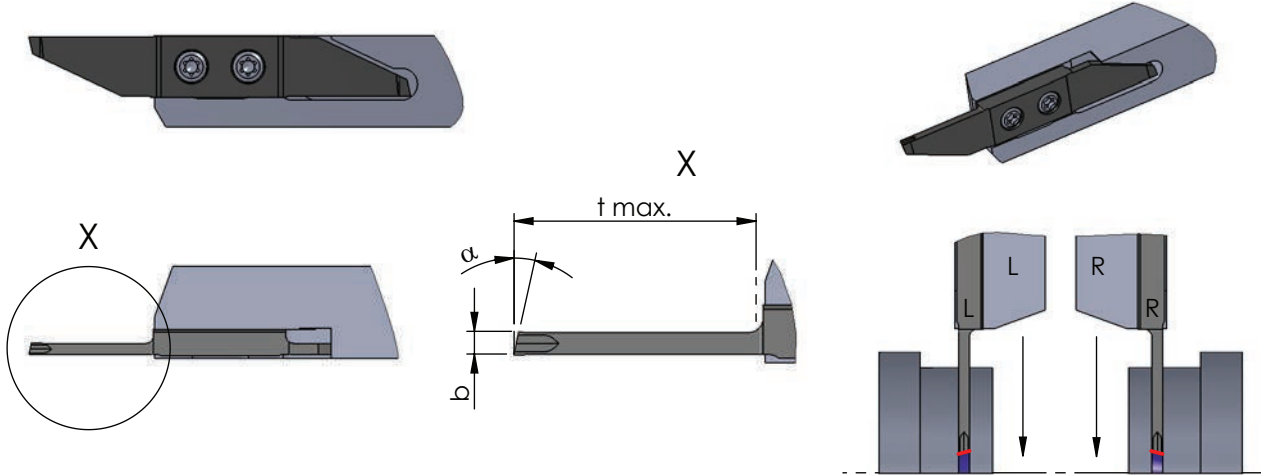

Rechts (R): wie gezeichnet
Links (L): spiegelbildlich

Rechte Schneidpl. in rechtem Halter
Linke Schneidpl. in linkem Halter

Abmessungen in mm

righthand version (R): as shown
lefthand version (L): mirror image

use RH insert in RH tool holder and
LH insert in LH tool holder

dimensions in mm

Bestellnummer part number	b	t max.	α	Klemmhalter Typ toolholder type			
				K10F	CN45F	AL41F	P18C
R/L ZW15.15081500	1.5	8	15°	●			●
R/L ZW15.15161500	1.5	16	15°	●			●
R/L ZW15.20101500	2.0	10	15°	●			●
R/L ZW15.20161500	2.0	16	15°	●			●
R/L ZW15.25131500	2.5	13	15°	●			●
R/L ZW15.25161500	2.5	16	15°	●			●
R/L ZW15.30161500	3.0	16	15°	●			●

Weitere HM Sorten können Sie in der Sortenübersicht im Kapitel "Technische Hinweise" und der Preisliste finden.

Bestellbeispiel:
für rechte Ausführung und Sorte
RZW15.15081500/P18C

More carbide grades you can find in the grades summary in the chapter "technical instructions" and in the price list.

order-example:
righthand version and grade
RZW15.15081500/P18C

SWISSLINE

Miniatöraußenbearbeitung,
zweischneidig

miniature external machining,
two-cutting edges

Typ ZW16

Wendeschneidplatten,
zum Abstechen,
mit Spantreppe

indexable inserts,
for parting off,
with chip breaker

Stechtiefe t max. = 8 - 16 mm
Stechbreite b = 1.5 - 3 mm

depth of groove t max. = 8 - 16 mm
width of groove b = 1.5 - 3 mm

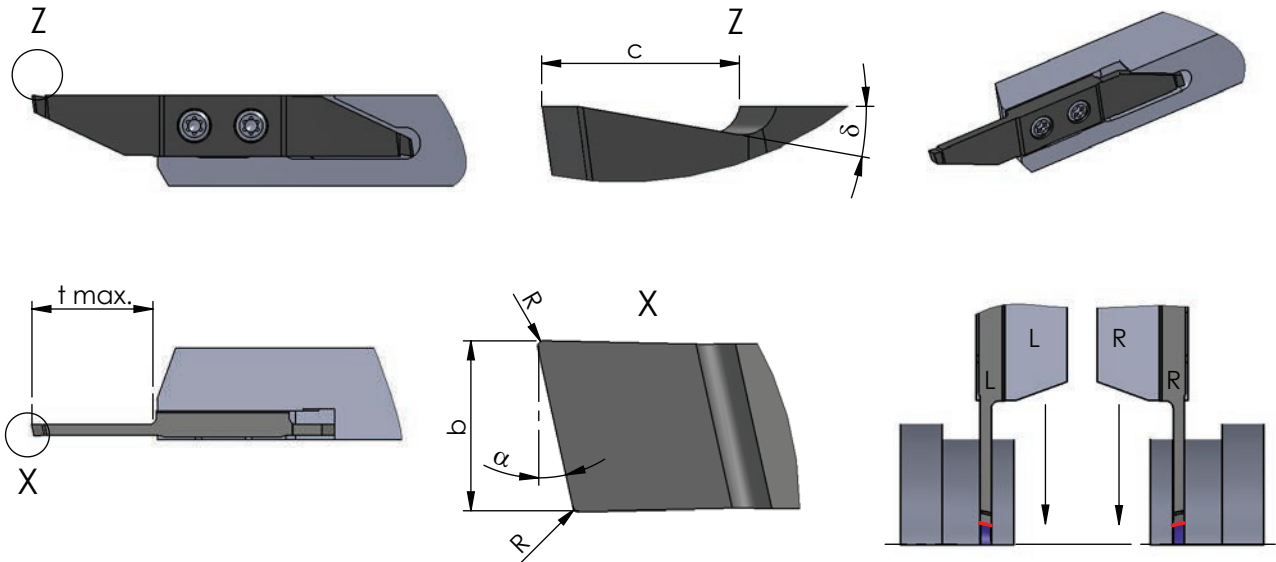

Rechts (R): wie gezeichnet
Links (L): spiegelbildlich

Rechte Schneidpl. in rechtem Halter
Linke Schneidpl. in linkem Halter

Abmessungen in mm

righthand version (R): as shown
lefthand version (L): mirror image

use RH insert in RH tool holder and
LH insert in LH tool holder

dimensions in mm



Bestellnummer part number	b	t max.	delta	R	alpha	c	Klemmhalter Typ toolholder type				
							K10F	CN45F	AL41F	P18C	
R/L ZW16.15080605	1.5	8	6°	0.05	15°	2	●				
R/L ZW16.15081205	1.5	8	12°	0.05	15°	2	●				
R/L ZW16.20100605	2.0	10	6°	0.05	15°	2	●				
R/L ZW16.20101205	2.0	10	12°	0.05	15°	2	●				
R/L ZW16.20102000	2.0	10	20°	-	15°	2	●				
R/L ZW16.20160605	2.0	16	6°	0.05	15°	2	●				
R/L ZW16.20161205	2.0	16	12°	0.05	15°	2	●				R/L HW10... R/L HW15... R/L HW20...
R/L ZW16.25130605	2.5	13	6°	0.05	15°	2	●				
R/L ZW16.25131205	2.5	13	12°	0.05	15°	2	●				
R/L ZW16.25160605	2.5	16	6°	0.05	15°	2	●				
R/L ZW16.25161205	2.5	16	12°	0.05	15°	2	●				
R/L ZW16.30160605	3.0	16	6°	0.05	15°	2	●				
R/L ZW16.30161205	3.0	16	12°	0.05	15°	2	●				

Weitere HM Sorten können Sie in der Sortenübersicht im Kapitel "Technische Hinweise" und der Preisliste finden.

Bestellbeispiel:
für rechte Ausführung und Sorte
RZW16.15080605/P18C

More carbide grades you can find in the grades summary in the chapter "technical instructions" and in the price list.

order-example:
righthand version and grade
RZW16.15080605/P18C

SWISSLINE

Miniatúraußenbearbeitung,
zweischneidig

miniature external machining,
two-cutting edges

Typ ZW17

Wendeschneidplatten,
zum Abstechen,
Schneide versetzt, mit Spantreppe

indexable inserts,
for parting off,
offset cutting edge, with chip breaker

Stechtiefe t max. = 8 - 16 mm
Stechbreite b = 1.5 - 3 mm

depth of groove t max. = 8 - 16 mm
width of groove b = 1.5 - 3 mm

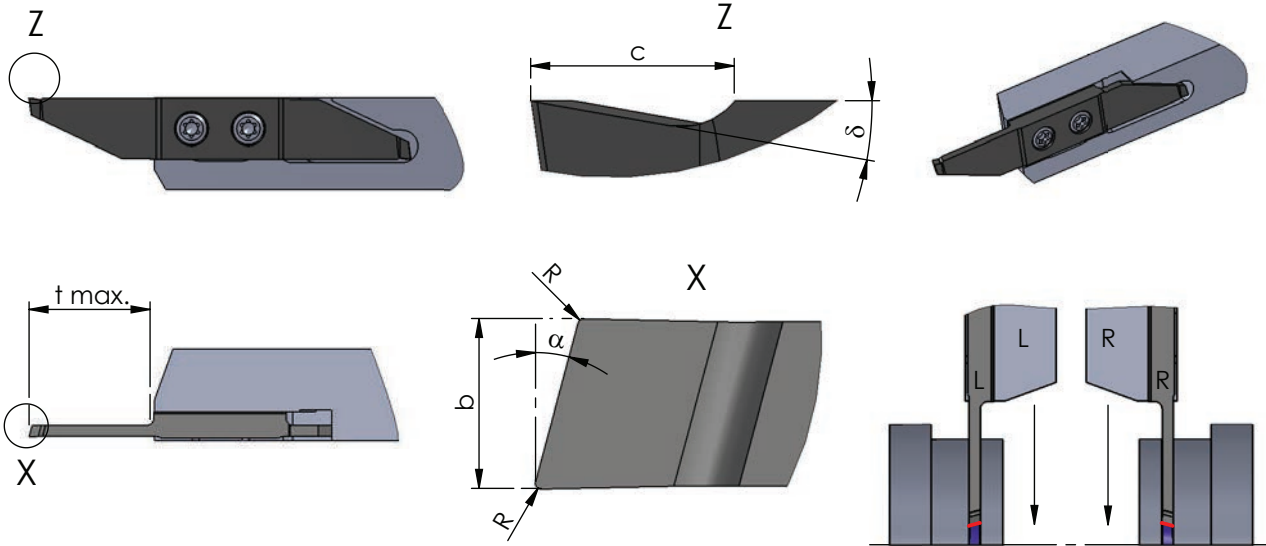

Rechts (R): wie gezeichnet
Links (L): spiegelbildlich

Rechte Schneidpl. in rechtem Halter
Linke Schneidpl. in linkem Halter

Abmessungen in mm

righthand version (R): as shown
lefthand version (L): mirror image

use RH insert in RH tool holder and
LH insert in LH tool holder

dimensions in mm

Bestellnummer part number	b	t max.	delta	R	alpha	c	Klemmhalter Typ toolholder type			
							K10F	CN45F	AL41F	P18C
R/L ZW17.15080605	1.5	8	6°	0.05	15°	2	●			
R/L ZW17.15081205	1.5	8	12°	0.05	15°	2	●			
R/L ZW17.20100605	2.0	10	6°	0.05	15°	2	●			
R/L ZW17.20101205	2.0	10	12°	0.05	15°	2	●			
R/L ZW17.20160605	2.0	16	6°	0.05	15°	2	●			
R/L ZW17.20161205	2.0	16	12°	0.05	15°	2	●			R/L HW10,...
R/L ZW17.25130605	2.5	13	6°	0.05	15°	2	●			R/L HW15,...
R/L ZW17.25131205	2.5	13	12°	0.05	15°	2	●			R/L HW20,...
R/L ZW17.25160605	2.5	16	6°	0.05	15°	2	●			
R/L ZW17.25161205	2.5	16	12°	0.05	15°	2	●			
R/L ZW17.30160605	3.0	16	6°	0.05	15°	2	●			
R/L ZW17.30161205	3.0	16	12°	0.05	15°	2	●			

Weitere HM Sorten können Sie in der Sorten-
übersicht im Kapitel "Technische Hinweise" und
der Preisliste finden.

Bestellbeispiel:
für rechte Ausführung und Sorte
RZW17.15080605/P18C

More carbide grades you can find in the grades
summary in the chapter "technical instructions"
and in the price list.

order-example:
righthand version and grade
RZW17.15080605/P18C

SWISSLINE

Miniatöraußenbearbeitung,
zweischneidig

miniature external machining,
two-cutting edges

Typ ZW18

Wendeschneidplatten,
zum Abstechen unter 0°,
mit Spanformer

indexable inserts,
for parting off with 0°,
with chip former

Stechtiefe t max. = 10 - 16 mm
Stechbreite b = 1.5 - 3 mm

depth of groove t max. = 10 - 16 mm
width of groove b = 1.5 - 3 mm

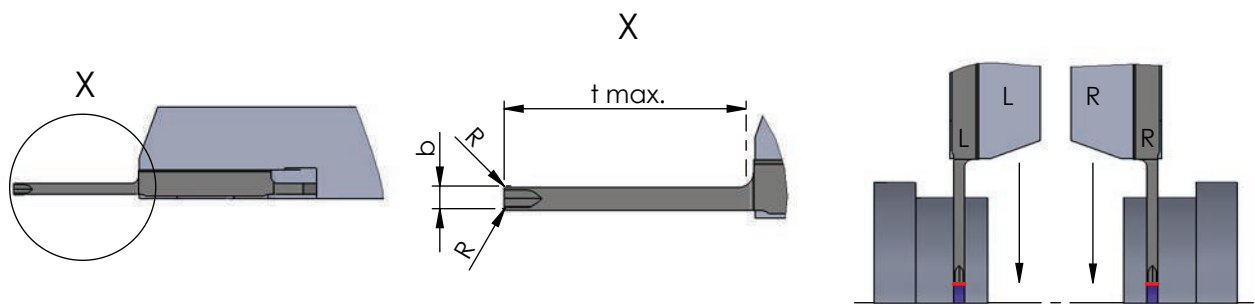
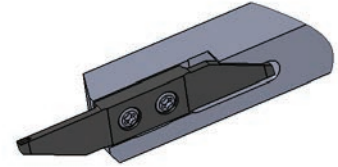

Rechts (R): wie gezeichnet
Links (L): spiegelbildlich

Rechte Schneidpl. in rechtem Halter
Linke Schneidpl. in linkem Halter

Abmessungen in mm

righthand version (R): as shown
lefthand version (L): mirror image

use RH insert in RH tool holder and
LH insert in LH tool holder

dimensions in mm



Bestellnummer part number	b	t max.	R	Klemmhalter Typ toolholder type			
				K10F	CN45F	AL41F	P18C
R/L ZW18.15100008	1.5	10	0.08	●			●
R/L ZW18.15160008	1.5	16	0.08	●			●
R/L ZW18.20100008	2.0	10	0.08	●			●
R/L ZW18.20160008	2.0	16	0.08	●			●
R/L ZW18.25130008	2.5	13	0.08	●			●
R/L ZW18.25160008	2.5	16	0.08	●			●
R/L ZW18.30160008	3.0	16	0.08	●			●

Weitere HM Sorten können Sie in der Sorten-
übersicht im Kapitel "Technische Hinweise" und
der Preisliste finden.

Bestellbeispiel:
für rechte Ausführung und Sorte
RZW18.15100008/P18C

More carbide grades you can find in the grades
summary in the chapter "technical instructions"
and in the price list.

order-example:
righthand version and grade
RZW18.15100008/P18C

SWISSLINE

Miniatúraußenbearbeitung,
zweischneidig

miniature external machining,
two-cutting edges

Typ ZW19

Wendeschneidplatten,
zum Abstechen unter 0°,
mit Spantrepe

indexable inserts,
for parting off with 0°,
with chip breaker

Stechtiefe t max. = 10 - 16 mm
Stechbreite b = 1.5 - 3 mm

depth of groove t max. = 10 - 16 mm
width of groove b = 1.5 - 3 mm

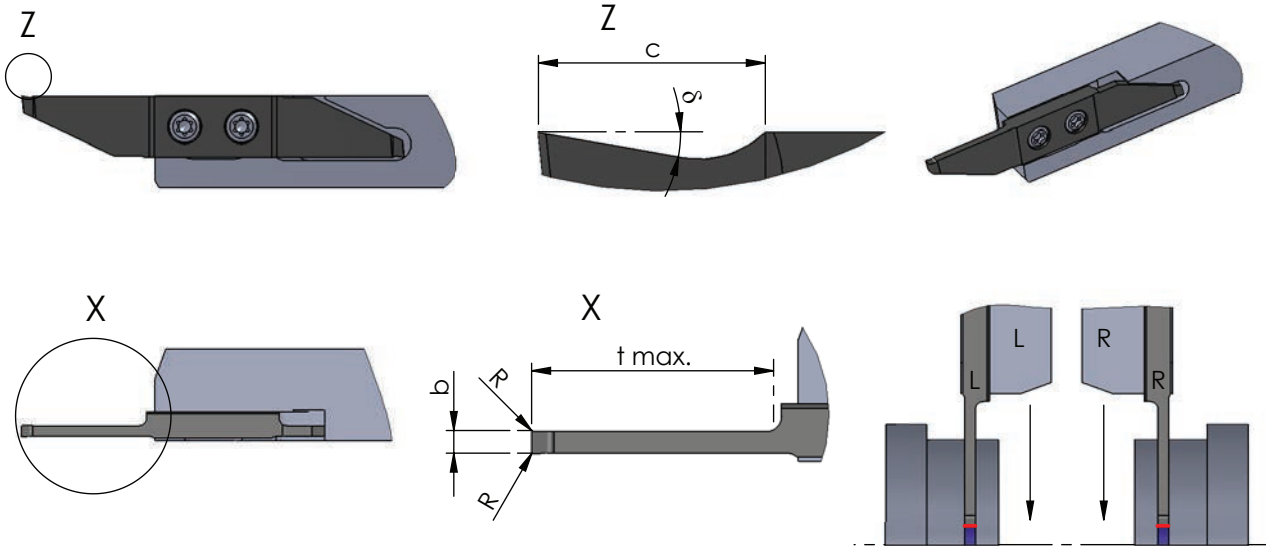

Rechts (R): wie gezeichnet
Links (L): spiegelbildlich

Rechte Schneidpl. in rechtem Halter
Linke Schneidpl. in linkem Halter

Abmessungen in mm

righthand version (R): as shown
lefthand version (L): mirror image

use RH insert in RH tool holder and
LH insert in LH tool holder

dimensions in mm

Bestellnummer part number	b	t max.	φ	R	c	Klemmhalter Typ toolholder type			
						K10F	CN45F	AL41F	P18C
R/L ZW19.15100605	1.5	10	6°	0.05	2	●			●
R/L ZW19.15101205	1.5	10	12°	0.05	2	●			●
R/L ZW19.20100605	2.0	10	6°	0.05	2	●			●
R/L ZW19.20101205	2.0	10	12°	0.05	2	●			●
R/L ZW19.20160605	2.0	16	6°	0.05	2	●			●
R/L ZW19.20161205	2.0	16	12°	0.05	2	●			●
R/L ZW19.25130605	2.5	13	6°	0.05	2	●			●
R/L ZW19.25131205	2.5	13	12°	0.05	2	●			●
R/L ZW19.25160605	2.5	16	6°	0.05	2	●			●
R/L ZW19.25161205	2.5	16	12°	0.05	2	●			●
R/L ZW19.30160605	3.0	16	6°	0.05	2	●			●
R/L ZW19.30161205	3.0	16	12°	0.05	2	●			●

Weitere HM Sorten können Sie in der Sortenübersicht im Kapitel "Technische Hinweise" und der Preisliste finden.

Bestellbeispiel:
für rechte Ausführung und Sorte
RZW19.15100605/P18C

More carbide grades you can find in the grades summary in the chapter "technical instructions" and in the price list.

order-example:
righthand version and grade
RZW19.15100605/P18C

SWISSLINE

Miniatúraußenbearbeitung,
zweischneidig

miniature external machining,
two-cutting edges

Typ ZW1A

Wendeschneidplatten,
zum Abstechen,
mit gesintertem Spanformer

indexable inserts,
for parting off,
with sintered chipformer

Stechtiefe t max. = 10 mm
Stechbreite b = 2 mm

depth of groove t max. = 10 mm
width of groove b = 2 mm



R/L ZW1A.201015GS: Schneide mit scharfer Schneidkante /
insert with sharp cutting edge

R/L ZW1A.201015GX: Schneide mit gerundeter Schneidkante /
insert with rounded cutting edge

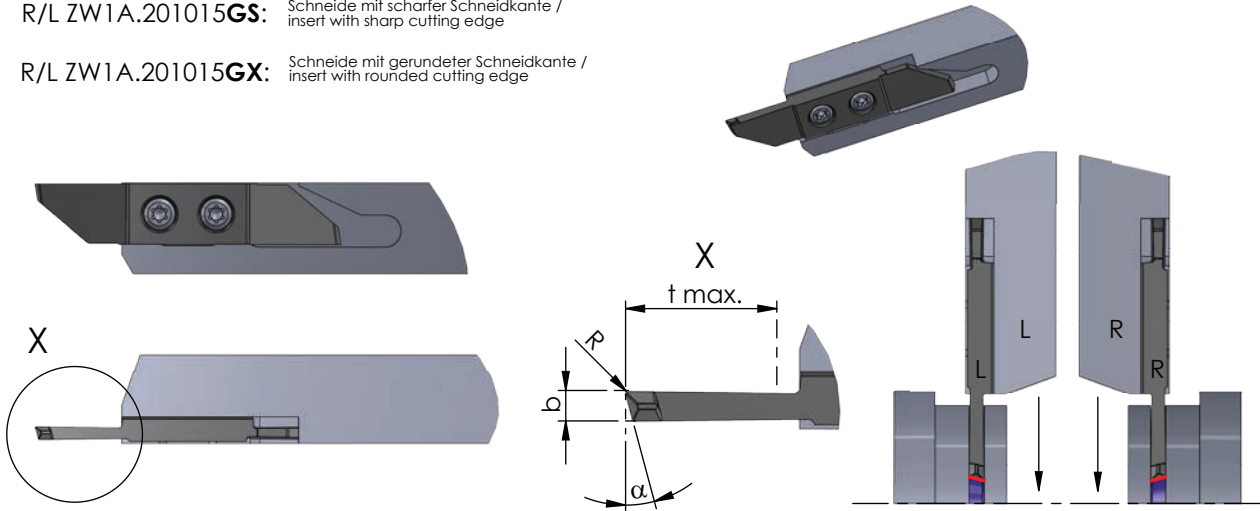

Rechts (R): wie gezeichnet
Links (L): spiegelbildlich

Rechte Schneidpl. in rechtem Halter
Linke Schneidpl. in linkem Halter

Abmessungen in mm

righthand version (R): as shown
lefthand version (L): mirror image

use RH insert in RH tool holder and
LH insert in LH tool holder

dimensions in mm



Bestellnummer part number	b	t max.	α	R	Klemmhalter Typ toolholder type				
					K10F	CN45F	AL41F	P18C	
neu R/L ZW1A.201015GS	2.0	10	15°	0.2	●	●	●	●	R/L HW10... R/L HW15... R/L HW20...
neu R/L ZW1A.201015GX	2.0	10	15°	0.2	●	●	●	●	

Weitere HM Sorten können Sie in der Sorten-
übersicht im Kapitel "Technische Hinweise" und
der Preisliste finden.

Bestellbeispiel:
für rechte Ausführung und Sorte
RZW1A.201015GS/P18C

More carbide grades you can find in the grades
summary in the chapter "technical instructions"
and in the price list.

order-example:
righthand version and grade
RZW1A.201015GS/P18C

SWISSLINE

Miniatöraußenbearbeitung,
zweischneidig

miniature external machining,
two-cutting edges

Typ ZW1B

Wendeschneidplatten,
zum Abstechen, Schneide versetzt,
mit gesintertem Spanformer

indexable inserts,
for parting off, offset cutting edge,
with sintered chipformer

Stechtiefe t max. = 10 mm
Stechbreite b = 2 mm

depth of groove t max. = 10 mm
width of groove b = 2 mm

R/L ZW1B.201015GS: Schneide mit scharfer Schneidkante /
insert with sharp cutting edge

R/L ZW1B.201015GX: Schneide mit gerundeter Schneidkante /
insert with rounded cutting edge

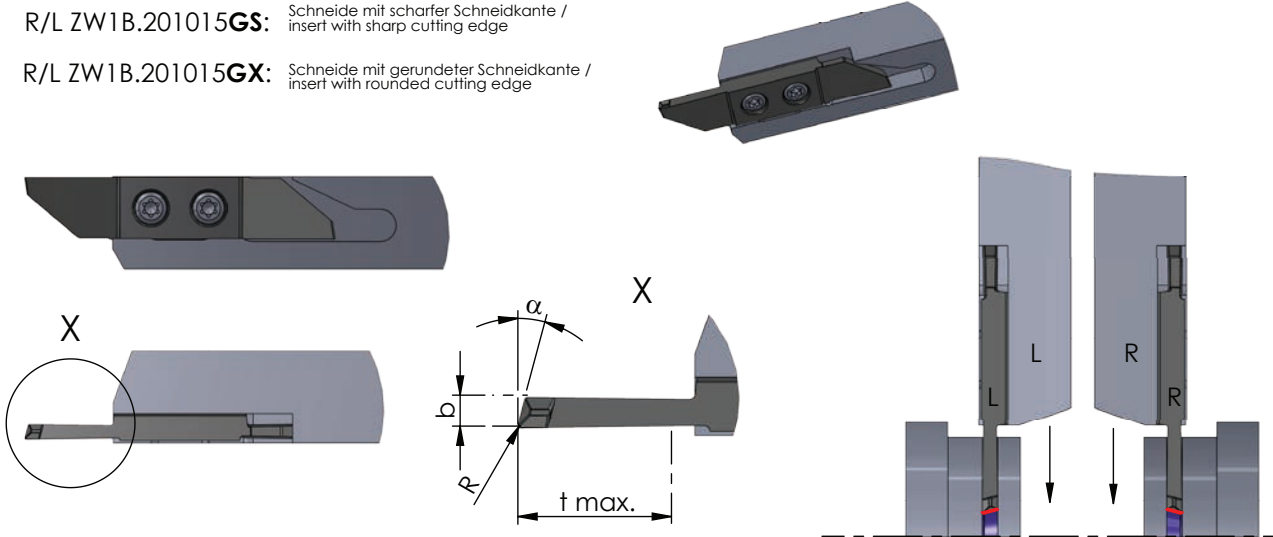

Rechts (R): wie gezeichnet
Links (L): spiegelbildlich

Rechte Schneidpl. in rechtem Halter
Linke Schneidpl. in linkem Halter

Abmessungen in mm

righthand version (R): as shown
lefthand version (L): mirror image

use RH insert in RH tool holder and
LH insert in LH tool holder

dimensions in mm

Bestellnummer part number	b	t max.	α	R	K10F	CN45F	AL41F	P18C	Klemmhalter Typ	toolholder type
neu R/L ZW1B.201015GS	2.0	10	15°	0.2	●			●	R/L HW10...	
neu R/L ZW1B.201015GX	2.0	10	15°	0.2	●			●	R/L HW15...	R/L HW20...

Weitere HM Sorten können Sie in der Sorten-
übersicht im Kapitel "Technische Hinweise" und
der Preisliste finden.

Bestellbeispiel:
für rechte Ausführung und Sorte
RZW1B.201015GS/P18C

More carbide grades you can find in the grades
summary in the chapter "technical instructions"
and in the price list.

order-example:
righthand version and grade
RZW1B.201015GS/P18C

SWISSLINE

Miniatöraußenbearbeitung,
zweischneidig

miniature external machining,
two-cutting edges

Typ ZW1C

Wendeschneidplatten,
zum Abstechen unter 0°,
mit gesintertem Spanformer

indexable inserts,
for parting off with 0°,
with sintered chip former

Stechtiefe t max. = 10 mm
Stechbreite b = 2 mm

depth of groove t max. = 10 mm
width of groove b = 2 mm



R/L ZW1C.201000GS: Schneide mit scharfer Schneidkante / insert with sharp cutting edge

R/L ZW1C.201000GX: Schneide mit gerundeter Schneidkante / insert with rounded cutting edge

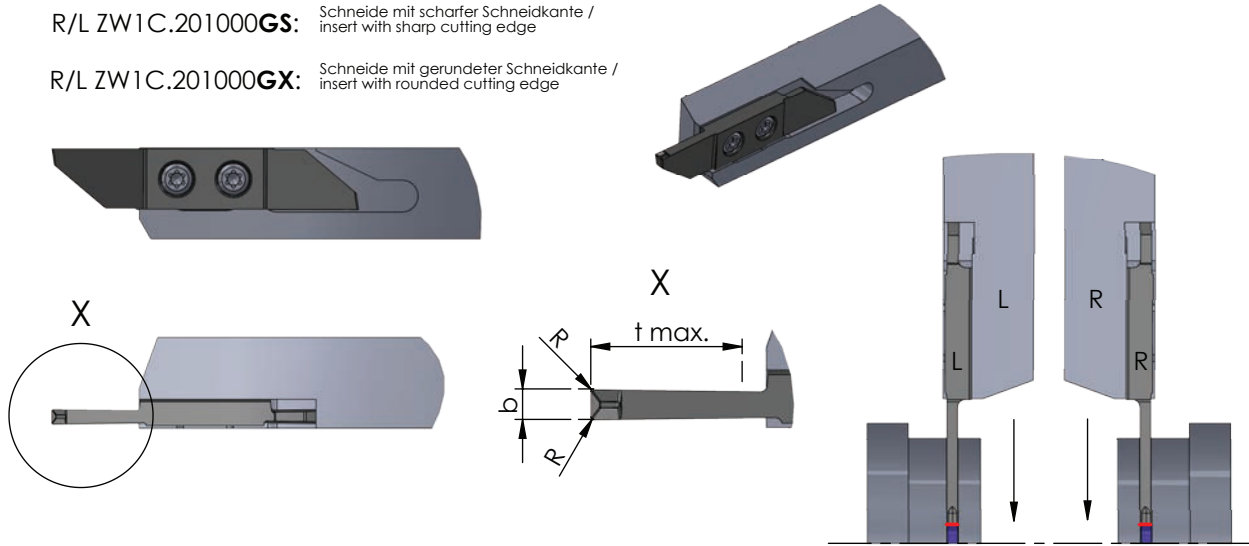

Rechts (R): wie gezeichnet
Links (L): spiegelbildlich

Rechte Schneidpl. in rechtem Halter
Linke Schneidpl. in linkem Halter

Abmessungen in mm

righthand version (R): as shown
lefthand version (L): mirror image

use RH insert in RH tool holder and
LH insert in LH tool holder

dimensions in mm

	Bestellnummer part number	b	t max.	R	Klemmhalter Typ toolholder type				
					K10F	CN45F	AL41F	P18C	
neu	R/L ZW1C.201000GS	2.0	10	0.2	●			●	R/L HW10... R/L HW15... R/L HW20...
neu	R/L ZW1C.201000GX	2.0	10	0.2	●			●	

Weitere HM Sorten können Sie in der Sortenübersicht im Kapitel "Technische Hinweise" und der Preisliste finden.

Bestellbeispiel:
für rechte Ausführung und Sorte
RZW1C.201000GS/P18C

More carbide grades you can find in the grades summary in the chapter "technical instructions" and in the price list.

order-example:
righthand version and grade
RZW1C.201000GS/P18C

SWISSLINE

Miniaturaußenbearbeitung,
zweischneidig

miniature external machining,
two-cutting edges

Typ ZW20

Wendeschneidplatten,
Drehen und Abstechen,
Wipergeometrie

indexable inserts,
turning and parting off,
wiper geometry

Stechtiefe $t \text{ max.} = 10 \text{ mm}$
Stechbreite $b = 2 \text{ mm}$

depth of groove $t \text{ max.} = 10 \text{ mm}$
width of groove $b = 2 \text{ mm}$

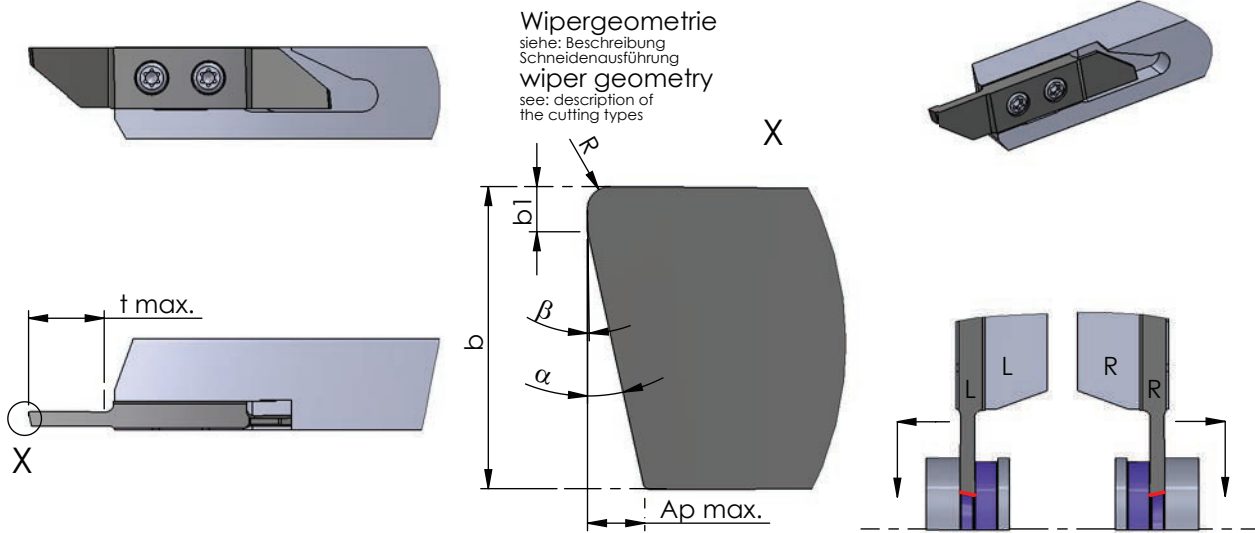

Rechts (R): wie gezeichnet
Links (L): spiegelbildlich

Rechte Schneidpl. in rechtem Halter
Linke Schneidpl. in linkem Halter

Abmessungen in mm

righthand version (R): as shown
lefthand version (L): mirror image

use RH insert in RH tool holder and
LH insert in LH tool holder

dimensions in mm

Bestellnummer part number	b	t max.	α	R	β	b1	Ap max. *	Klemmhalter Typ toolholder type				
								K10F	CN45F	AL41F	P18C	
R/L ZW20.20101515	2	10	15°	0.15	1.5°	0.3	0.45	●		●		R/L HW10... R/L HW15... R/L HW20...

*Ap max. = max. Schnitttiefe(werkstoffabhängig)

Weitere HM Sorten können Sie in der Sorten-
übersicht im Kapitel "Technische Hinweise" und
der Preisliste finden.

Bestellbeispiel: für rechte Ausführung und Sorte
RZW20.20101515/P18C

*Ap max. = maximum depth of cut
(depending on material)

More carbide grades you can find in the grades
summary in the chapter "technical instructions"
and in the price list.
order-example: righthand version and grade
RZW20.20101515/P18C

SWISSLINE

Miniaturaußenbearbeitung,
zweischneidig

miniature external machining,
two-cutting edges

Typ ZW21

Wendeschneidplatten,
Drehen und Abstechen,
Schneide versetzt, Wipergeometrie

indexable inserts,
turning and parting off,
offset cutting edge, wiper geometry

Stechtiefe $t \text{ max.} = 10 \text{ mm}$
Stechbreite $b = 2 \text{ mm}$

depth of groove $t \text{ max.} = 10 \text{ mm}$
width of groove $b = 2 \text{ mm}$

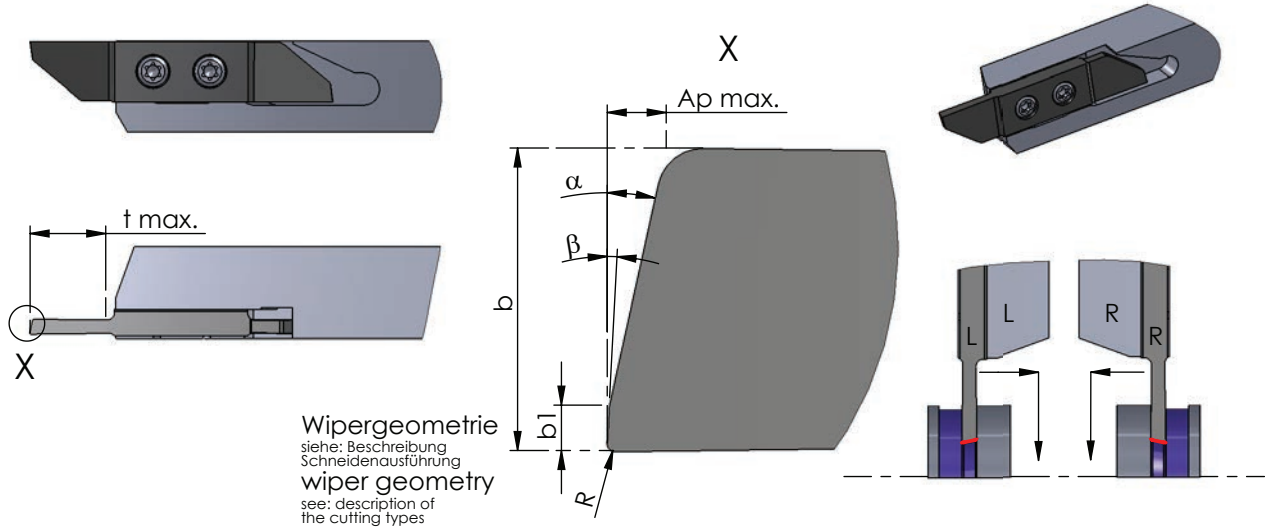

Rechts (R): wie gezeichnet
Links (L): spiegelbildlich

Rechte Schneidpl. in rechtem Halter
Linke Schneidpl. in linkem Halter

Abmessungen in mm

righthand version (R): as shown
lefthand version (L): mirror image

use RH insert in RH tool holder and
LH insert in LH tool holder

dimensions in mm

Bestellnummer part number	b	t max.	α	R	β	b1	Ap max. *	Klemmhalter Typ toolholder type			
								K10F	CN45F	AL41F	P18C
R/L ZW21.20101515	2	10	15°	0.15	1.5°	0.3	0.45	●		●	R/L HW10... R/L HW15... R/L HW20...

*Ap max. = max. Schnitttiefe(werkstoffabhängig)

Weitere HM Sorten können Sie in der Sorten-
übersicht im Kapitel "Technische Hinweise" und
der Preisliste finden.

Bestellbeispiel: für rechte Ausführung und Sorte
RZW21.20101515/P18C

*Ap max. = maximum depth of cut
(depending on material)

More carbide grades you can find in the grades
summary in the chapter "technical instructions"
and in the price list.
order-example: righthand version and grade
RZW21.20101515/P18C

SWISSLINE

Miniaturaußenbearbeitung,
zweischneidig

miniature external machining,
two-cutting edges

Typ ZW22

Wendeschneidplatten,
Drehen und Abstechen,
mit Spanformer, Wipergeometrie

indexable inserts,
turning and parting off,
with chipformer, wiper geometry

Stechtiefe t max. = 10 mm
Stechbreite b = 2 mm

depth of groove t max. = 10 mm
width of groove b = 2 mm

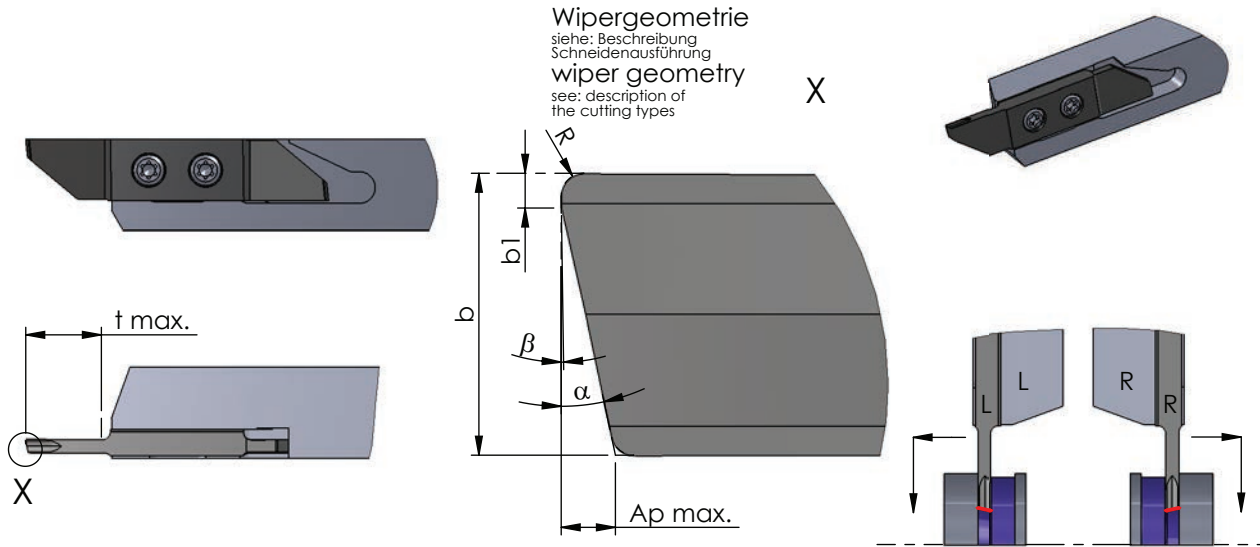

Rechts (R): wie gezeichnet
Links (L): spiegelbildlich

Rechte Schneidpl. in rechtem Halter
Linke Schneidpl. in linkem Halter

Abmessungen in mm

righthand version (R): as shown
lefthand version (L): mirror image

use RH insert in RH tool holder and
LH insert in LH tool holder

dimensions in mm

Bestellnummer part number	b	t max.	α	R	β	b1	Ap max. *	Klemmhalter Typ toolholder type				
								K10F	CN45F	AL41F	P18C	
R/L ZW22.20101515	2	10	15°	0.15	1.5°	0.3	0.45	●		●		R/L HW10... R/L HW15... R/L HW20...

*Ap max. = max. Schnitttiefe(werkstoffabhängig)

Weitere HM Sorten können Sie in der Sorten-
übersicht im Kapitel "Technische Hinweise" und
der Preisliste finden.

Bestellbeispiel: für rechte Ausführung und Sorte
RZW22.20101515/P18C

*Ap max. = maximum depth of cut
(depending on material)

More carbide grades you can find in the grades
summary in the chapter "technical instructions"
and in the price list.
order-example: righthand version and grade
RZW22.20101515/P18C

SWISSLINE

Miniaturaußenbearbeitung,
zweischneidig

miniature external machining,
two-cutting edges

Typ ZW23

Wendeschneidplatten,
Drehen u. Abstechen, Schneide versetzt,
mit Spanformer, Wipergeometrie

indexable inserts,
turning and parting off,
offset cutting edge, with chipformer,
wiper geometry

Stechtiefe t max. = 10 mm
Stechbreite b = 2 mm

depth of groove t max. = 10 mm
width of groove b = 2 mm

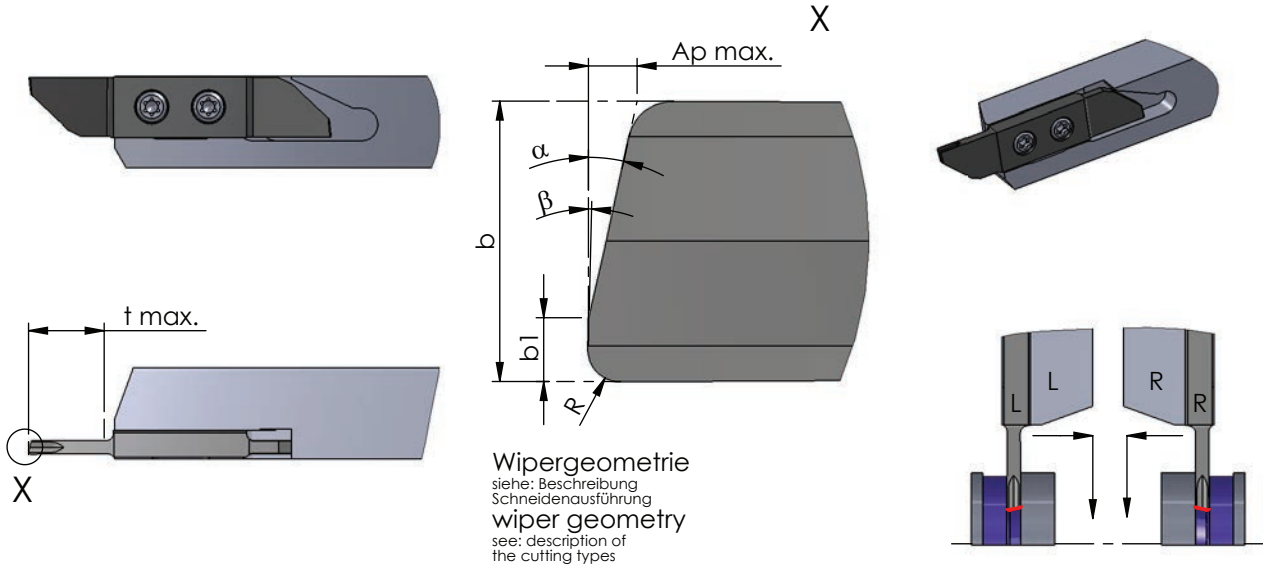

Rechts (R): wie gezeichnet
Links (L): spiegelbildlich

Rechte Schneidpl. in rechtem Halter
Linke Schneidpl. in linkem Halter

Abmessungen in mm

righthand version (R): as shown
lefthand version (L): mirror image

use RH insert in RH tool holder and
LH insert in LH tool holder

dimensions in mm

Bestellnummer part number	b	t max.	α	R	β	b1	Ap max. *	Klemmhalter Typ toolholder type			
								K10F	CN45F	AL41F	P18C
R/L ZW23.20101515	2	10	15°	0.15	1.5°	0.3	0.45	●		●	R/L HW10... R/L HW15... R/L HW20...

*Ap max. = max. Schnitttiefe(werkstoffabhängig)

Weitere HM Sorten können Sie in der Sorten-
übersicht im Kapitel "Technische Hinweise" und
der Preisliste finden.

Bestellbeispiel: für rechte Ausführung und Sorte
RZW23.20101515/P18C

*Ap max. = maximum depth of cut
(depending on material)

More carbide grades you can find in the grades
summary in the chapter "technical instructions"
and in the price list.
order-example: righthand version and grade
RZW23.20101515/P18C

SWISSLINE

Miniatöraußenbearbeitung,
zweischneidig

miniature external machining,
two-cutting edges

Typ ZW30

Wendeschneidplatten,
Vornedrehen

indexable inserts,
turning in front

Stechtiefe t max. = 8 mm
Stechbreite b = 3.4 mm

depth of groove t max. = 8 mm
width of groove b = 3.4 mm

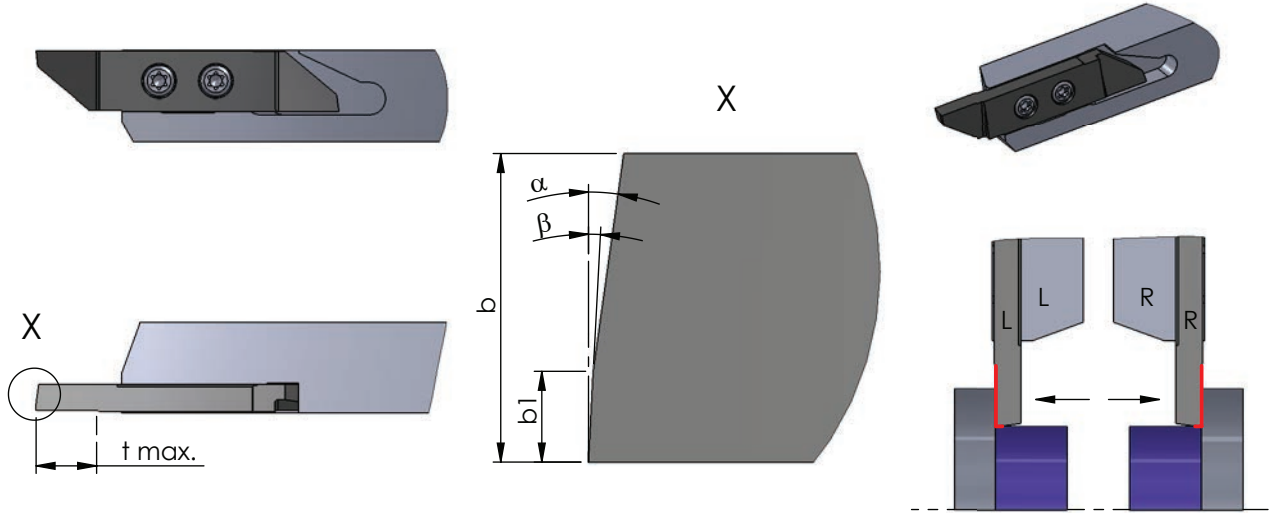

Rechts (R): wie gezeichnet
Links (L): spiegelbildlich

Rechte Schneidpl. in rechtem Halter
Linke Schneidpl. in linkem Halter

Abmessungen in mm

righthand version (R): as shown
lefthand version (L): mirror image

use RH insert in RH tool holder and
LH insert in LH tool holder

dimensions in mm

Bestellnummer part number	b	t max.	α	b1	β	K10F	CN45F	AL41F	P18C	Klemmhalter Typ	
										toolholder type	
R/L ZW30.34080800	3.4	8	8°	1	3°	●			●	R/L HW10... R/L HW15... R/L HW20...	

Weitere HM Sorten können Sie in der Sorten-
übersicht im Kapitel "Technische Hinweise" und
der Preisliste finden.

Bestellbeispiel:
für rechte Ausführung und Sorte
RZW30.34080800/P18C

More carbide grades you can find in the grades
summary in the chapter "technical instructions"
and in the price list.

order-example:
righthand version and grade
RZW30.34080800/P18C

SWISSLINE

Miniatöraußenbearbeitung,
zweischneidig

miniature external machining,
two-cutting edges

Typ ZW31

Wendeschneidplatten,
Vornedrehen,
mit Spanformer, Wipergeometrie

indexable inserts,
turning in front,
with chip former, wiper geometry

Stechtiefe t max. = 8 mm
Stechbreite b = 3.4 mm

depth of groove t max. = 8 mm
width of groove b = 3.4 mm

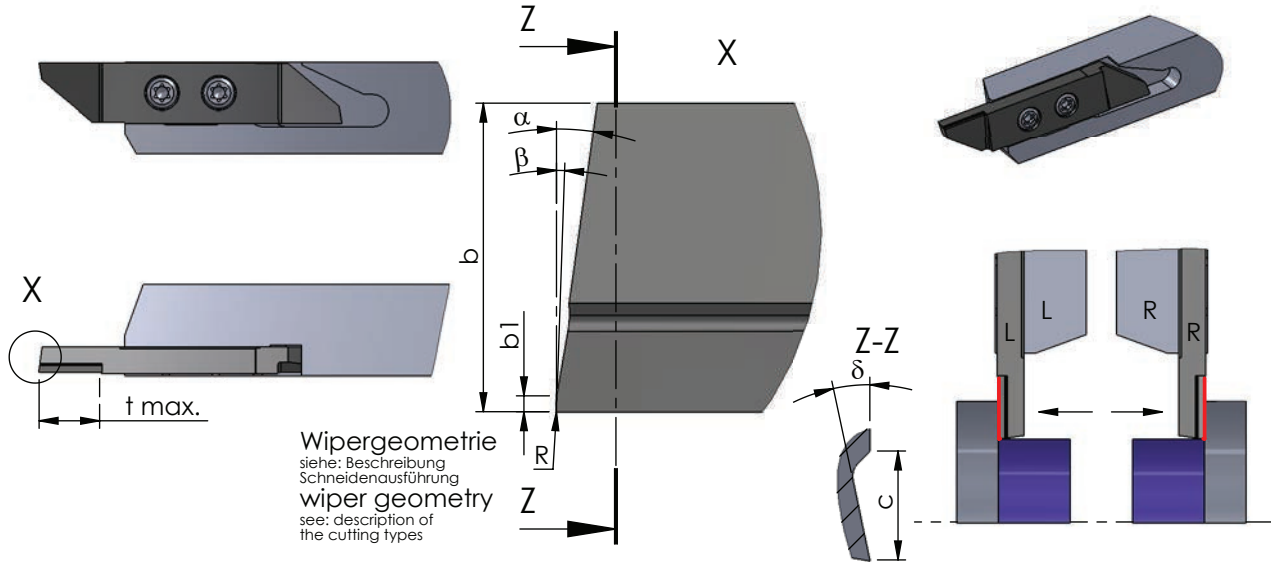

Rechts (R): wie gezeichnet
Links (L): spiegelbildlich

Rechte Schneidpl. in rechtem Halter
Linke Schneidpl. in linkem Halter

Abmessungen in mm

righthand version (R): as shown
lefthand version (L): mirror image

use RH insert in RH tool holder and
LH insert in LH tool holder

dimensions in mm



Bestellnummer part number	b	t max.	α	R	b1	β	c	δ	K10F	CN45F	AL41F	P18C	Klemmhalter Typ	toolholder type
R/L ZW31.34080800	3.4	8	8°	0	0.2	1°	1.2	12°	●			●		R/L HW10...
R/L ZW31.34084508	3.4	8	45°	0.08	1.2	1°	1.2	12°	●			●		R/L HW15...
R/L ZW31.34084515	3.4	8	45°	0.15	1.2	1°	1.2	12°	●			●		R/L HW20...

Weitere HM Sorten können Sie in der Sorten-
übersicht im Kapitel "Technische Hinweise" und
der Preisliste finden.

Bestellbeispiel:
für rechte Ausführung und Sorte
RZW31.34080800/P18C

More carbide grades you can find in the grades
summary in the chapter "technical instructions"
and in the price list.

order-example:
righthand version and grade
RZW31.34080800/P18C

SWISSLINE

Miniatöraußenbearbeitung,
zweischneidig

miniature external machining,
two-cutting edges

Typ ZW40

Wendeschneidplatten,
Kopierdrehen vorne,
Schneide versetzt, mit Spanformer

indexable inserts,
profiling in front,
offset cutting edge, with chip former

Stechtiefe t max. = 11 mm
Stechbreite b = 3.2 mm

depth of groove t max. = 11 mm
width of groove b = 3.2 mm

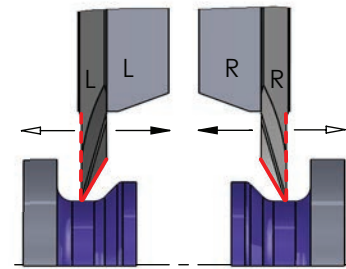
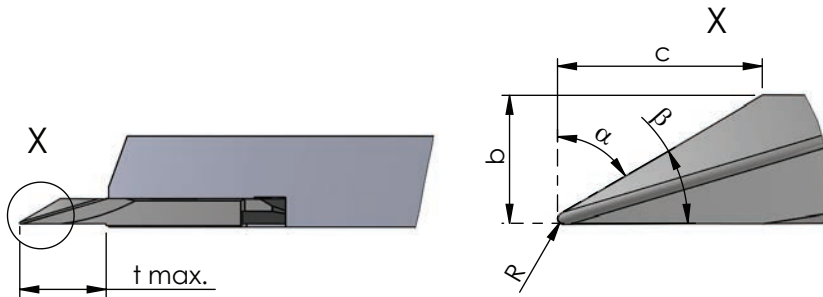
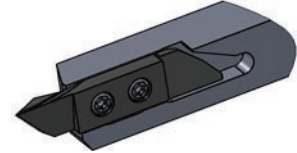

Rechts (R): wie gezeichnet
Links (L): spiegelbildlich

Rechte Schneidpl. in rechtem Halter
Linke Schneidpl. in linkem Halter

Abmessungen in mm

righthand version (R): as shown
lefthand version (L): mirror image

use RH insert in RH tool holder and
LH insert in LH tool holder

dimensions in mm

Bestellnummer part number	b	t max.	α	R	β	c	Klemmhalter Typ toolholder type			
							K10F	CN45F	AL41F	P18C
R/L ZW40.32116108	3.2	11	61°	0.08	29°	5	●		●	
R/L ZW40.32116115	3.2	11	61°	0.15	29°	5	●		●	R/L HW10... R/L HW15... R/L HW20...
R/L ZW40.32116135	3.2	11	61°	0.35	29°	5	●		●	
R/L ZW40.32116175	3.2	11	61°	0.75	29°	5	●		●	

Weitere HM Sorten können Sie in der Sorten-
übersicht im Kapitel "Technische Hinweise" und
der Preisliste finden.

Bestellbeispiel:
für rechte Ausführung und Sorte
RZW40.32116108/P18C

More carbide grades you can find in the grades
summary in the chapter "technical instructions"
and in the price list.

order-example:
righthand version and grade
RZW40.32116108/P18C

SWISSLINE

Miniatöraußenbearbeitung,
zweischneidig

miniature external machining,
two-cutting edges

Typ ZW41

Wendeschneidplatten,
Kopierdrehen hinten,
mit Spanformer

indexable inserts,
profiling at the back,
with chipformer

Stechtiefe t max. = 11 mm
Stechbreite b = 3.2 mm

depth of groove t max. = 11 mm
width of groove b = 3.2 mm

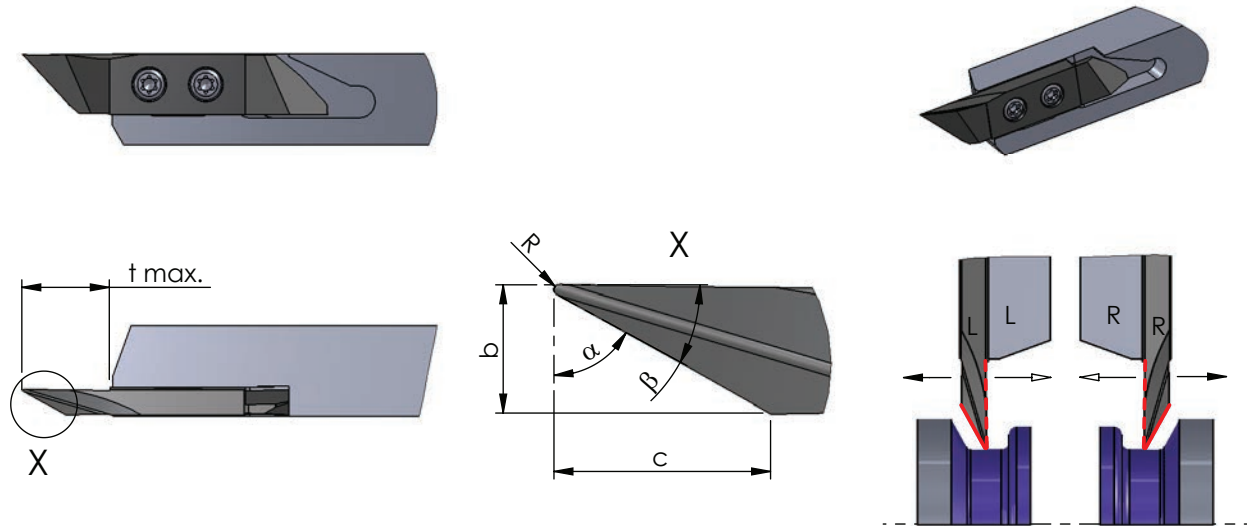

Rechts (R): wie gezeichnet
Links (L): spiegelbildlich

Rechte Schneidpl. in rechtem Halter
Linke Schneidpl. in linkem Halter

Abmessungen in mm

righthand version (R): as shown
lefthand version (L): mirror image

use RH insert in RH tool holder and
LH insert in LH tool holder

dimensions in mm



Bestellnummer part number	b	t max.	α	R	β	c					Klemmhalter Typ toolholder type
							K10F	CN45F	AL41F	P18C	
R/L ZW41.32115515	3.2	11	55°	0.15	35°	4	●			●	R/L HW10, ... R/L HW15, ... R/L HW20, ...
R/L ZW41.32115535	3.2	11	55°	0.35	35°	4	●			●	
R/L ZW41.32116108	3.2	11	61°	0.08	29°	5	●			●	
R/L ZW41.32116115	3.2	11	61°	0.15	29°	5	●			●	
R/L ZW41.32116135	3.2	11	61°	0.35	29°	5	●			●	
R/L ZW41.32116175	3.2	11	61°	0.75	29°	5	●			●	

Weitere HM Sorten können Sie in der Sorten-
übersicht im Kapitel "Technische Hinweise" und
der Preisliste finden.

Bestellbeispiel:
für rechte Ausführung und Sorte
RZW41.32115515/P18C

More carbide grades you can find in the grades
summary in the chapter "technical instructions"
and in the price list.

order-example:
righthand version and grade
RZW41.32115515/P18C

SWISSLINE

Miniatöraußenbearbeitung,
zweischneidig

miniature external machining,
two-cutting edges

Typ ZW50

Wendeschneidplatten,
Hintendreher, Wipergeometrie

indexable inserts,
turning at the back, wiper geometry

Stechtiefe t max. = 6 - 8 mm
Stechbreite b = 0.8 - 1.8 mm

depth of groove t max. = 6 - 8 mm
width of groove b = 0.8 - 1.8 mm

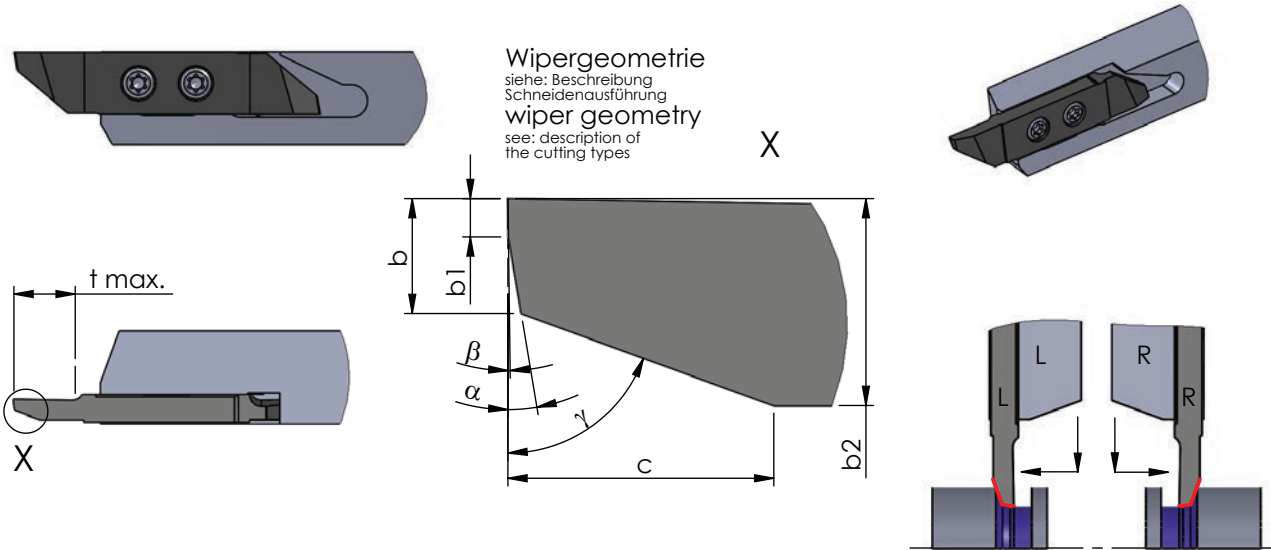

Wipergeometrie
siehe: Beschreibung
Schneidenausführung
wiper geometry
see: description of
the cutting types

Rechts (R): wie gezeichnet
Links (L): spiegelbildlich

Rechte Schneidpl. in rechtem Halter
Linke Schneidpl. in linkem Halter

Abmessungen in mm

righthand version (R): as shown
lefthand version (L): mirror image

use RH insert in RH tool holder and
LH insert in LH tool holder

dimensions in mm

Bestellnummer part number	b	t max.	α	b1	b2	β	γ	c	K10F	CN45F	AL41F	P18C	Klemmhalter Typ	toolholder type
R/L ZW50.08060800	0.8	6	8°	0.5	2	1°	70°	3	●			●	R/L HW10.... R/L HW15.... R/L HW20....	
R/L ZW50.10060800	1.0	6	8°	0.5	2.2	1°	70°	3	●			●		
R/L ZW50.12080800	1.2	8	8°	0.5	2.4	1°	70°	3	●			●		
R/L ZW50.15080800	1.5	8	8°	0.5	2.7	1°	70°	3	●			●		
R/L ZW50.18080800	1.8	8	8°	0.5	3.0	1°	70°	3	●			●		

Weitere HM Sorten können Sie in der Sorten-
übersicht im Kapitel "Technische Hinweise" und
der Preisliste finden.

Bestellbeispiel:
für rechte Ausführung und Sorte
RZW50.08060800/P18C

More carbide grades you can find in the grades
summary in the chapter "technical instructions"
and in the price list.

order-example:
righthand version and grade
RZW50.08060800/P18C

SWISSLINE

Miniatöraußenbearbeitung,
zweischneidig

miniature external machining,
two-cutting edges

Typ ZW51

Wendeschneidplatten,
Kopierdrehen hinten,
mit Spanformer, Wipergeometrie

indexable inserts,
profiling at the back,
with chip former, wiper geometry

Stechtiefe t max. = 6 mm
Stechbreite b = 0.5 mm

depth of groove t max. = 6 mm
width of groove b = 0.5 mm

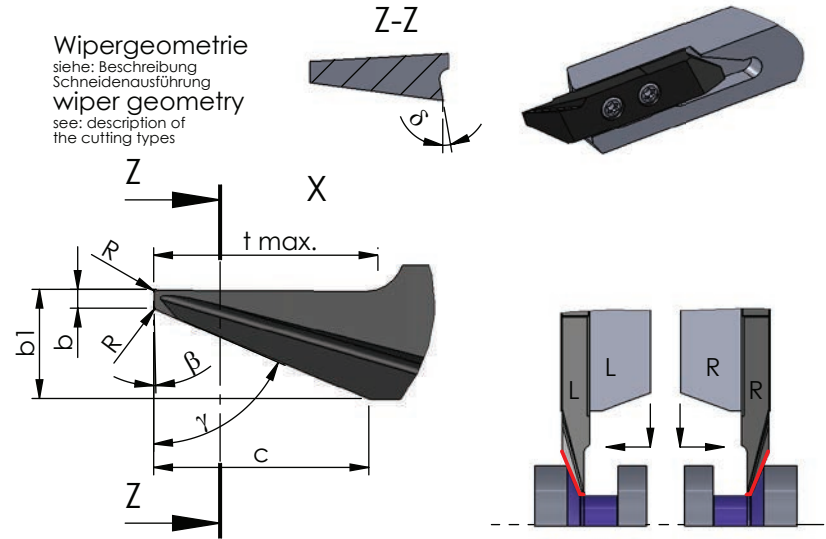
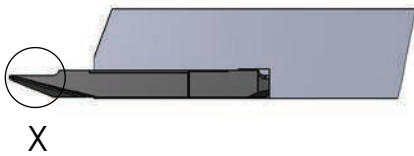

Wipergeometrie
siehe: Beschreibung
Schneidenausführung
wiper geometry
see: description of
the cutting types

Rechts (R): wie gezeichnet
Links (L): spiegelbildlich

Rechte Schneidpl. in rechtem Halter
Linke Schneidpl. in linkem Halter

Abmessungen in mm

righthand version (R): as shown
lefthand version (L): mirror image

use RH insert in RH tool holder and
LH insert in LH tool holder

dimensions in mm



Bestellnummer part number	b	t max.	γ	R	b1	β	δ	c					Klemmhalter Typ toolholder type
									K10F	CN45F	AL41F	P18C	
R/L ZW51.05067000	0.5	6	70°	0	2.4	1.5°	15°	5	●			●	R/L HW10...
R/L ZW51.05067008	0.5	6	70°	0.08	2.4	1.5°	15°	5	●			●	R/L HW15...
R/L ZW51.05067015	0.5	6	70°	0.15	2.4	1.5°	15°	5	●			●	R/L HW20...

Weitere HM Sorten können Sie in der Sorten-
übersicht im Kapitel "Technische Hinweise" und
der Preisliste finden.

Bestellbeispiel:
für rechte Ausführung und Sorte
RZW51.05067000/P18C

More carbide grades you can find in the grades
summary in the chapter "technical instructions"
and in the price list.

order-example:
righthand version and grade
RZW51.05067000/P18C

SWISSLINE

Miniatöraußenbearbeitung,
zweischneidig

miniature external machining,
two-cutting edges

Typ ZW52

Wendeschneidplatten,
Hintendrehen,
mit Spantreppe

indexable inserts,
turning at the back,
with chip breaker

Stechtiefe t max. = 4.5 mm
Stechbreite b = 0.8 mm

depth of groove t max. = 4.5 mm
width of groove b = 0.8 mm

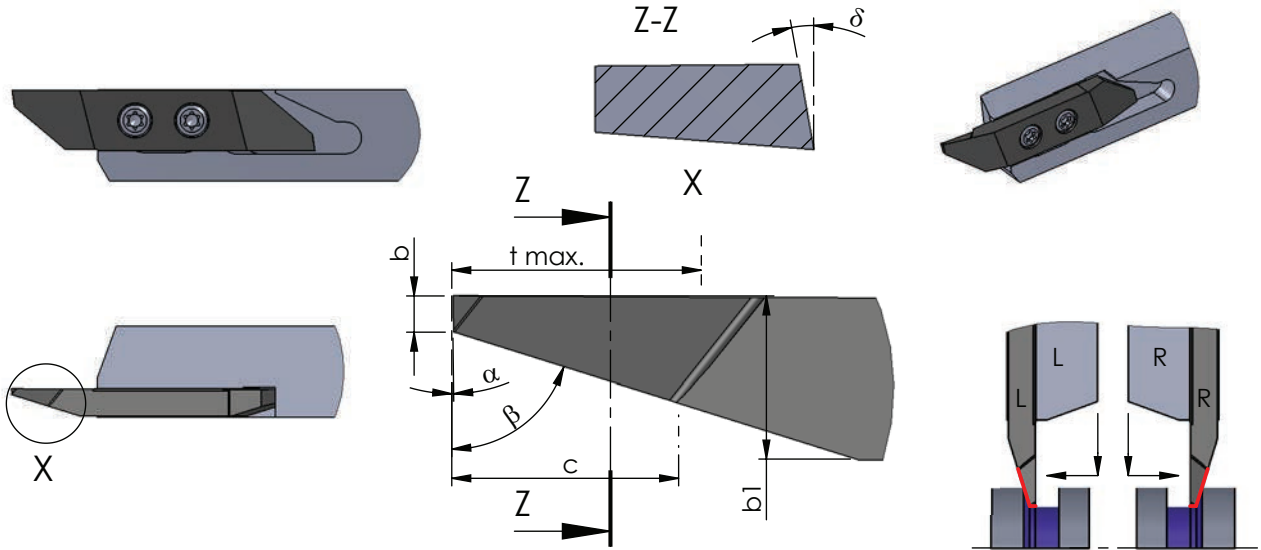

Rechts (R): wie gezeichnet
Links (L): spiegelbildlich

Rechte Schneidpl. in rechtem Halter
Linke Schneidpl. in linkem Halter

Abmessungen in mm

righthand version (R): as shown
lefthand version (L): mirror image

use RH insert in RH tool holder and
LH insert in LH tool holder

dimensions in mm

Bestellnummer part number	b	t max.	β	b1	α	δ	c	K10F	CN45F	AL41F	P18C	Klemmhalter Typ	toolholder type	
R/L ZW52.08047000	0.8	4.5	70°	3.2	2°	7°	4	●	●	●	●	R/L HW10...	R/L HW15...	R/L HW20...

Weitere HM Sorten können Sie in der Sorten-
übersicht im Kapitel "Technische Hinweise" und
der Preisliste finden.

Bestellbeispiel:
für rechte Ausführung und Sorte
RZW52.08047000/P18C

More carbide grades you can find in the grades
summary in the chapter "technical instructions"
and in the price list.

order-example:
righthand version and grade
RZW52.08047000/P18C

SWISSLINE

Miniatöraußenbearbeitung,
zweischneidig

miniature external machining,
two-cutting edges

Typ ZW60

Wendeschneidplatten,
Einstechen und Längsdrehen

indexable inserts,
grooving and turning

Stechtiefe t max. = 2.5 - 6 mm
Stechbreite b = 1 - 3 mm

depth of groove t max. = 2.5 - 6 mm
width of groove b = 1 - 3 mm

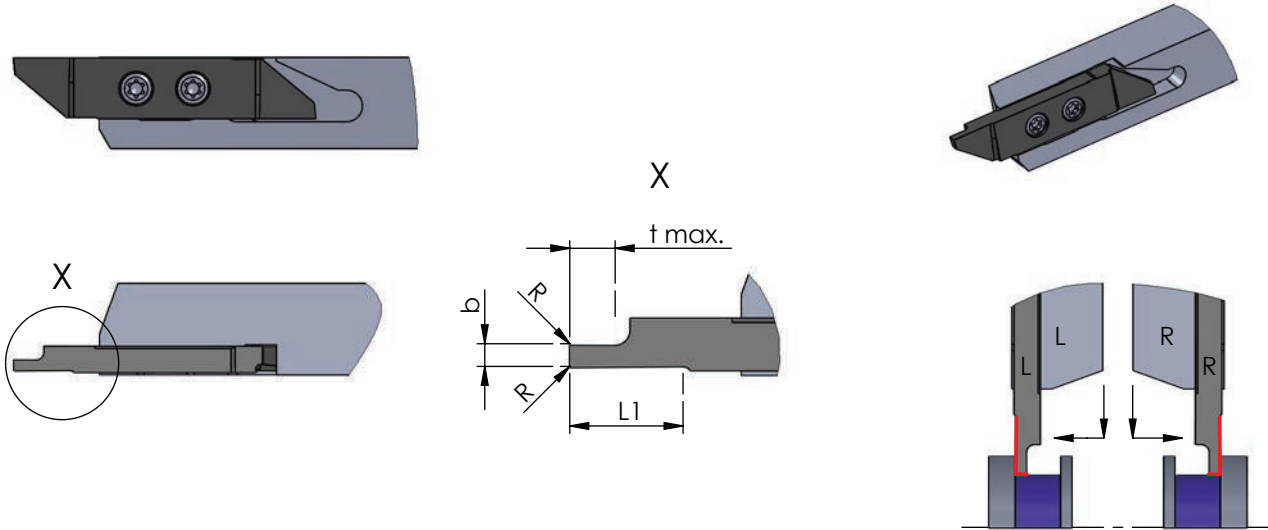

Rechts (R): wie gezeichnet
Links (L): spiegelbildlich

Rechte Schneidpl. in rechtem Halter
Linke Schneidpl. in linkem Halter

Abmessungen in mm

righthand version (R): as shown
lefthand version (L): mirror image

use RH insert in RH tool holder and
LH insert in LH tool holder

dimensions in mm

Bestellnummer part number	b	t max.	R	L1					Klemmhalter Typ toolholder type
					K10F	CN45F	AL41F	P18C	
R/L ZW60.10250005	1.0	2.5	0.05	8	●			●	R/L HW10... R/L HW15... R/L HW20...
R/L ZW60.15300005	1.5	3.0	0.05	8	●			●	
R/L ZW60.20400005	2.0	4.0	0.05	8	●			●	
R/L ZW60.25500005	2.5	5.0	0.05	8	●			●	
R/L ZW60.30600005	3.0	6.0	0.05	8	●			●	

Weitere HM Sorten können Sie in der Sorten-
übersicht im Kapitel "Technische Hinweise" und
der Preisliste finden.

Bestellbeispiel:
für rechte Ausführung und Sorte
RZW60.10250005/P18C

More carbide grades you can find in the grades
summary in the chapter "technical instructions"
and in the price list.

order-example:
righthand version and grade
RZW60.10250005/P18C

SWISSLINE

Miniatúraußenbearbeitung,
zweischneidig

miniature external machining,
two-cutting edges

Typ ZW61

Wendeschneidplatten,
Einstechen und Längsdrehen,
mit Spantrepe

indexable inserts,
grooving and turning,
with chip breaker

Stechtiefe t max. = 2.5 - 6 mm
Stechbreite b = 0.8 - 3 mm

depth of groove t max. = 2.5 - 6 mm
width of groove b = 0.8 - 3 mm

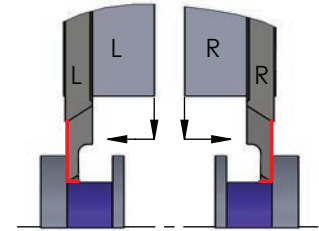
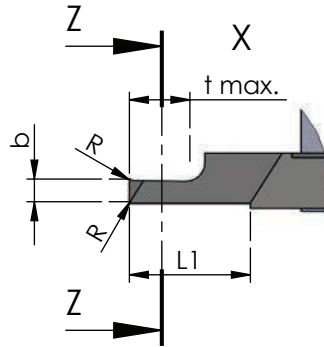
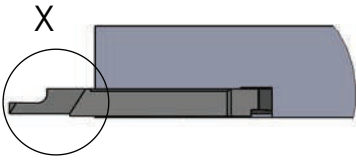
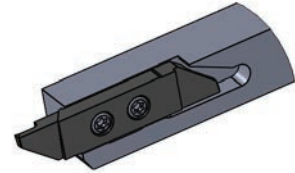
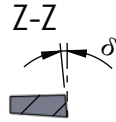

Rechts (R): wie gezeichnet
Links (L): spiegelbildlich

Rechte Schneidpl. in rechtem Halter
Linke Schneidpl. in linkem Halter

Abmessungen in mm

righthand version (R): as shown
lefthand version (L): mirror image

use RH insert in RH tool holder and
LH insert in LH tool holder

dimensions in mm

Bestellnummer part number	b	t max.	R	L1	ϕ					Klemmhalter Typ toolholder type
						K10F	CN45F	AL41F	P18C	
R/L ZW61.08250000	0.8	2.5	0	8	10°	●			●	R/L HW10... R/L HW15... R/L HW20...
R/L ZW61.10350000	1.0	3.5	0	8	10°	●			●	
R/L ZW61.15400000	1.5	4.0	0	8	10°	●			●	
R/L ZW61.15400008	1.5	4.0	0.08	8	10°	●			●	
R/L ZW61.20500000	2.0	5.0	0	8	10°	●			●	
R/L ZW61.20500008	2.0	5.0	0.08	8	10°	●			●	
R/L ZW61.20500015	2.0	5.0	0.15	8	10°	●			●	
R/L ZW61.25600000	2.5	6.0	0	8	10°	●			●	
R/L ZW61.25600008	2.5	6.0	0.08	8	10°	●			●	
R/L ZW61.25600015	2.5	6.0	0.15	8	10°	●			●	
R/L ZW61.30600000	3.0	6.0	0	8	10°	●			●	
R/L ZW61.30600008	3.0	6.0	0.08	8	10°	●			●	
R/L ZW61.30600015	3.0	6.0	0.15	8	10°	●			●	

Weitere HM Sorten können Sie in der Sortenübersicht im Kapitel "Technische Hinweise" und der Preisliste finden.

Bestellbeispiel:
für rechte Ausführung und Sorte
RZW61.08250000/P18C

More carbide grades you can find in the grades summary in the chapter "technical instructions" and in the price list.

order-example:
righthand version and grade
RZW61.08250000/P18C

SWISSLINE

Miniaturaußenbearbeitung,
zweischneidig

miniature external machining,
two-cutting edges

Typ ZW70

Wendeschneidplatten,
Stechdrehen,
Vollradius mit Spantreppe

indexable inserts,
grooving,
full radius with chip breaker

Stechtiefe t max. = 2 - 16 mm
Stechbreite b = 0.5 - 3 mm

depth of groove t max. = 2 - 16 mm
width of groove b = 0.5 - 3 mm

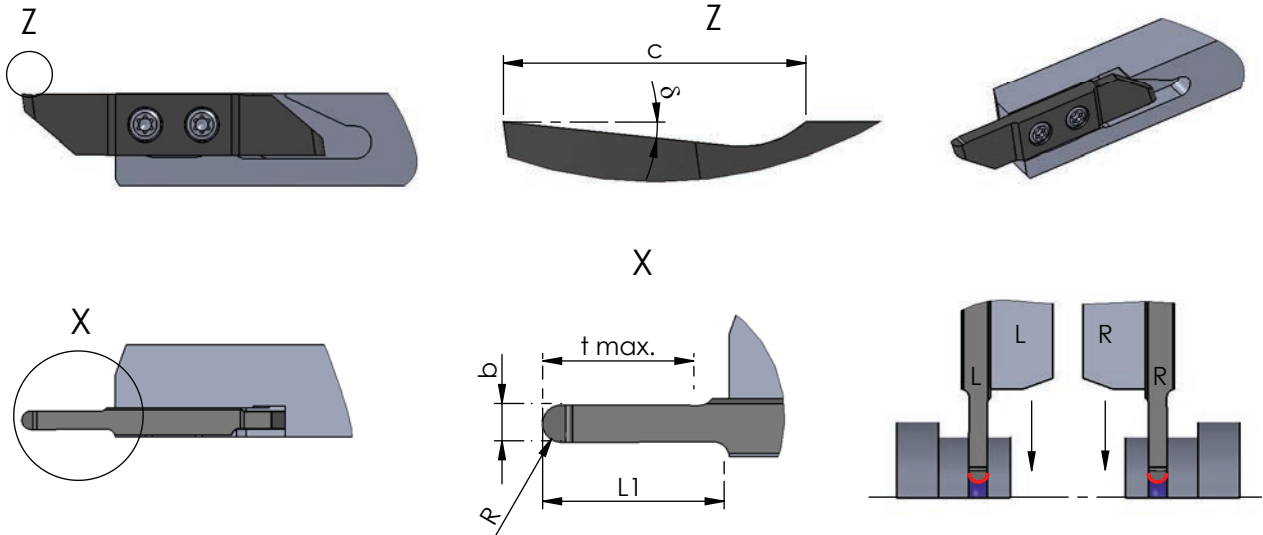

Rechts (R): wie gezeichnet
Links (L): spiegelbildlich

Rechte Schneidpl. in rechtem Halter
Linke Schneidpl. in linkem Halter

Abmessungen in mm

righthand version (R): as shown
lefthand version (L): mirror image

use RH insert in RH tool holder and
LH insert in LH tool holder

dimensions in mm

Bestellnummer part number	b	R	t max.	L1	α	c					Klemmhalter Typ toolholder type	
							K10F	CN45F	AL41F	P18C		
R/L ZW70.0502020	0.5	0.25	2.0	12	6°	2	●					
R/L ZW70.1005025	1.0	0.50	2.5	12	6°	2	●					
R/L ZW70.1206025	1.2	0.60	2.5	12	6°	2	●					
R/L ZW70.1507030	1.5	0.75	3.0	12	6°	2	●					R/L HW10... R/L HW15... R/L HW20...
R/L ZW70.1608030	1.6	0.80	3.0	12	6°	2	●					
R/L ZW70.2010100	2.0	1.00	10	12	6°	2	●					
R/L ZW70.3015100	3.0	1.50	10	12	6°	2	●					
R/L ZW70.3015160	3.0	1.50	16	17	6°	2	●					

Weitere HM Sorten können Sie in der Sorten-
übersicht im Kapitel "Technische Hinweise" und
der Preisliste finden.

Bestellbeispiel:
für rechte Ausführung und Sorte
RZW70.0502020/P18C

More carbide grades you can find in the grades
summary in the chapter "technical instructions"
and in the price list.

order-example:
righthand version and grade
RZW70.0502020/P18C

SWISSLINE

Miniatöraußenbearbeitung,
zweischneidig

miniature external machining,
two-cutting edges

Typ ZW90

Wendeschneidplatten,
Gewindedrehen,
Vollprofil, 60°

indexable inserts,
threading,
full profile, 60°

Gewinde M1 - M4.5
Steigung P = 0.25 - 0.75

thread M1 - M4.5
pitch P = 0.25 - 0.75

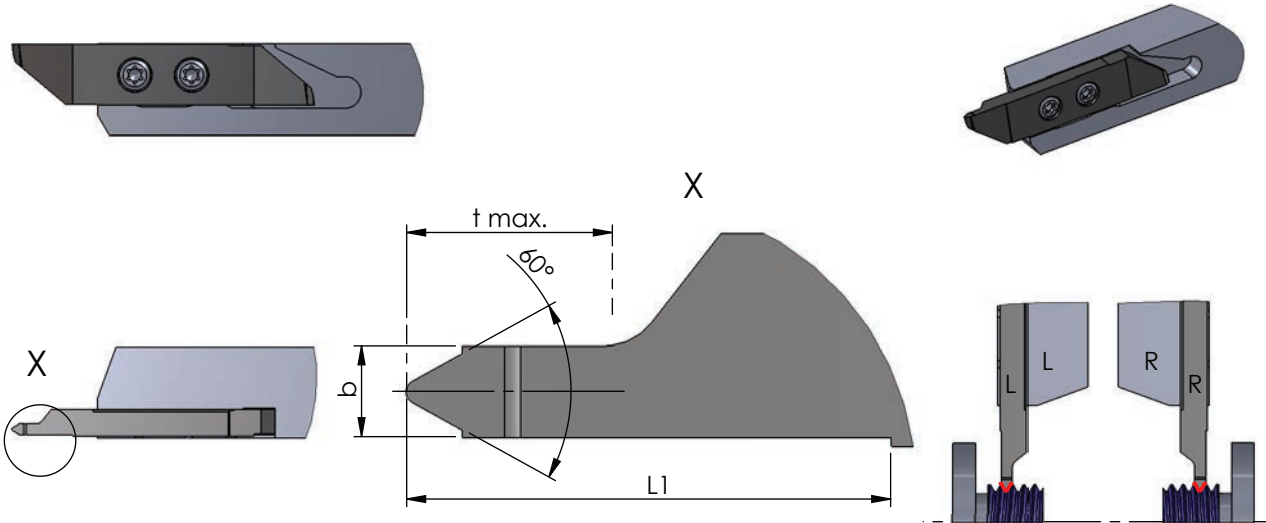

Rechts (R): wie gezeichnet
Links (L): spiegelbildlich

Rechte Schneidpl. in rechtem Halter
Linke Schneidpl. in linkem Halter

Abmessungen in mm

righthand version (R): as shown
lefthand version (L): mirror image

use RH insert in RH tool holder and
LH insert in LH tool holder

dimensions in mm

Bestellnummer part number	Gewindegröße thread size	Steigung P pitch P				K10F	CN45F	AL41F	P18C	Klemmhalter Typ toolholder type
			b	L1	t max.					
R/L ZW90.VP60025	M1 / M1.2	0.25	0.28	8	0	●			●	R/L HW10... R/L HW15... R/L HW20...
R/L ZW90.VP60030	M1.4	0.30	0.34	8	0	●			●	
R/L ZW90.VP60035	M1.6 / M1.8	0.35	0.38	8	0	●			●	
R/L ZW90.VP60040	M2	0.4	0.44	8	0	●			●	
R/L ZW90.VP60045	M2.2 / M2.5	0.45	0.50	8	0	●			●	
R/L ZW90.VP60050	M3	0.5	0.70	8	1.4	●			●	
R/L ZW90.VP60060	M3.5	0.6	0.80	8	1.4	●			●	
R/L ZW90.VP60070	M4	0.7	0.90	8	1.8	●			●	
R/L ZW90.VP60075	M4.5	0.75	0.90	8	1.9	●			●	

Weitere HM Sorten können Sie in der Sorten-
übersicht im Kapitel "Technische Hinweise" und
der Preisliste finden.

Bestellbeispiel:
für rechte Ausführung und Sorte
RZW90.VP60025/P18C

More carbide grades you can find in the grades
summary in the chapter "technical instructions"
and in the price list.

order-example:
righthand version and grade
RZW90.VP60025/P18C

SWISSLINE

Miniaturaußenbearbeitung,
zweischneidig

miniature external machining,
two-cutting edges

Typ ZW90

Wendeschneidplatten,
Gewindedrehen,
Vollprofil, 60°

indexable inserts,
threading,
full profile, 60°

Gewinde M5 - M27
Steigung P = 0.8 - 3

thread M5 - M27
pitch P = 0.8 - 3

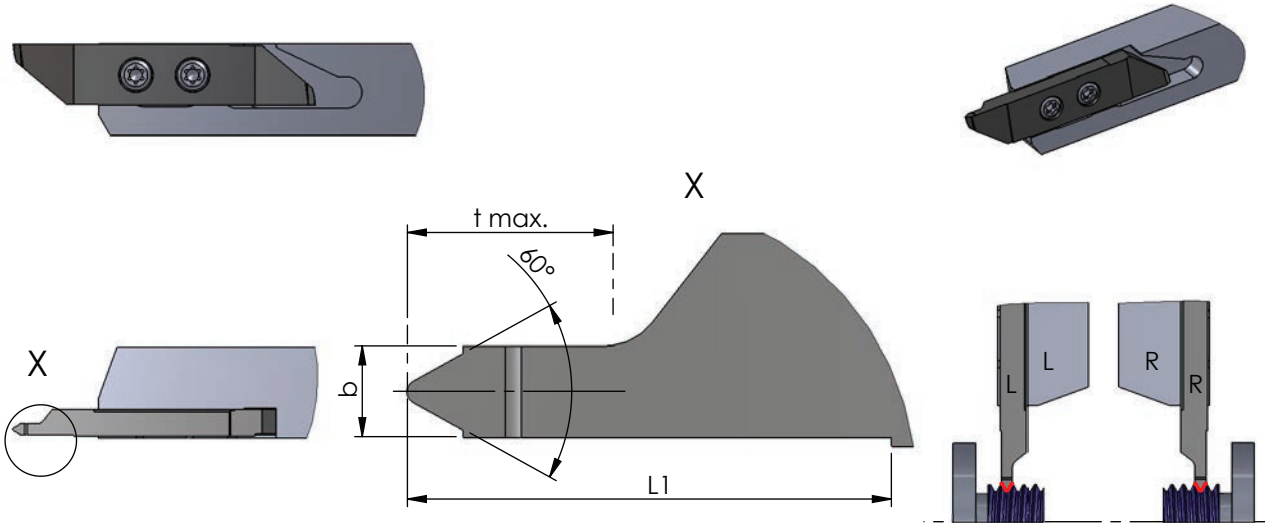

Rechts (R): wie gezeichnet
Links (L): spiegelbildlich

Rechte Schneidpl. in rechtem Halter
Linke Schneidpl. in linkem Halter

Abmessungen in mm

righthand version (R): as shown
lefthand version (L): mirror image

use RH insert in RH tool holder and
LH insert in LH tool holder

dimensions in mm



Bestellnummer part number	Gewindegröße thread size	Steigung P pitch P	b	L1	t max.					Klemmhalter Typ toolholder type
						K10F	CN45F	AL41F	P18C	
R/L ZW90.VP60080	M5	0.8	1.00	8	2.0	●			●	R/L HW10... R/L HW15... R/L HW20...
R/L ZW90.VP60100	M6 / M7	1.0	1.10	8	2.4	●			●	
R/L ZW90.VP60125	M8	1.25	1.46	8	2.9	●			●	
R/L ZW90.VP60150	M10 / M11	1.50	1.74	8	3.4	●			●	
R/L ZW90.VP60175	M12	1.75	1.96	8	3.9	●			●	
R/L ZW90.VP60200	M14 / M16	2.00	2.20	8	4.0	●			●	
R/L ZW90.VP60250	M18 / M20 / M22	2.50	2.80	8	5.0	●			●	
R/L ZW90.VP60300	M24 / M27	3.00		8	5.0	●			●	

Weitere HM Sorten können Sie in der Sorten-
übersicht im Kapitel "Technische Hinweise" und
der Preisliste finden.

Bestellbeispiel:
für rechte Ausführung und Sorte
RZW90.VP60080/P18C

More carbide grades you can find in the grades
summary in the chapter "technical instructions"
and in the price list.

order-example:
righthand version and grade
RZW90.VP60080/P18C

SWISSLINE

Miniatúraußenbearbeitung,
zweischneidig

miniature external machining,
two-cutting edges

Typ ZW94

Wendeschneidplatten,
Gewindedrehen,
Teilprofil, 55° / 60°

indexable inserts,
threading,
partial profile, 55° / 60°

Steigung P = 0.25 - 2

pitch P = 0.25 - 2

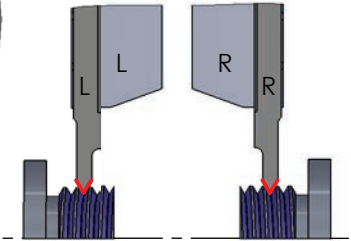
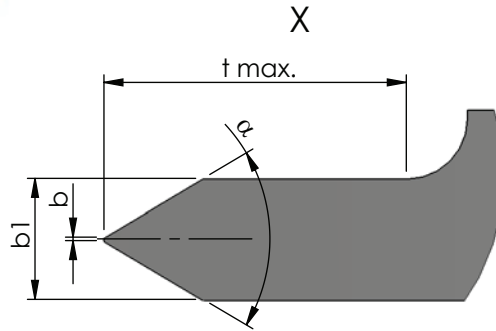
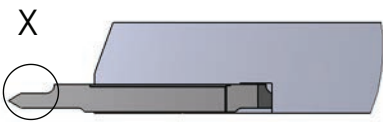
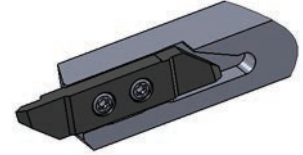

Rechts (R): wie gezeichnet
Links (L): spiegelbildlich

Rechte Schneidpl. in rechtem Halter
Linke Schneidpl. in linkem Halter

Abmessungen in mm

righthand version (R): as shown
lefthand version (L): mirror image

use RH insert in RH tool holder and
LH insert in LH tool holder

dimensions in mm

Bestellnummer part number	Steigung P pitch P	α	t max.	b	b1					Klemmhalter Typ toolholder type
						K10F	CN45F	AL41F	P18C	
R/L ZW94.TP5506	0.25 - 2	55°	6	0.035	2	●			●	R/L HW10... R/L HW15... R/L HW20...
R/L ZW94.TP5510	0.25 - 2	55°	10	0.035	3	●			●	
R/L ZW94.TP6006	0.25 - 2	60°	6	0.035	2	●			●	
R/L ZW94.TP6010	0.25 - 2	60°	10	0.035	3	●			●	

Weitere HM Sorten können Sie in der Sorten-
übersicht im Kapitel "Technische Hinweise" und
der Preisliste finden.

Bestellbeispiel:
für rechte Ausführung und Sorte
RZW94.TP5506/P18C

More carbide grades you can find in the grades
summary in the chapter "technical instructions"
and in the price list.

order-example:
righthand version and grade
RZW94.TP5506/P18C

SWISSLINE

Miniaturaußenbearbeitung,
zweischneidig

miniature external machining,
two-cutting edges

Technische Hinweise

Beschreibung der Schneidenausführungen

Technical instructions,
Description of the cutting types

Bezeichnung Schneide

Das Merkmal "vorne" und "hinten" bezieht sich nicht auf die Richtung der Bearbeitung, sondern zeigt an, auf welcher Seite eine senkrechte Flanke erstellt werden kann mit der entsprechenden Schneide.

Description cutting edge

The description "front" or "back" means not the cutting direction, this shows the side which can produce an upright flank.

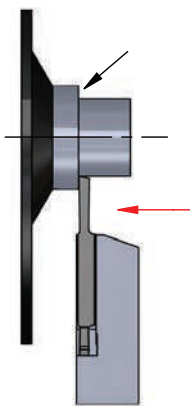

"VORNE"

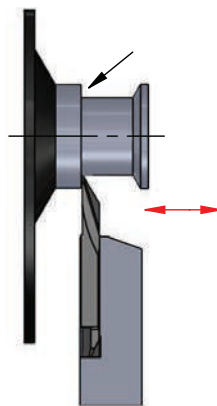

"VORNE" kopieren

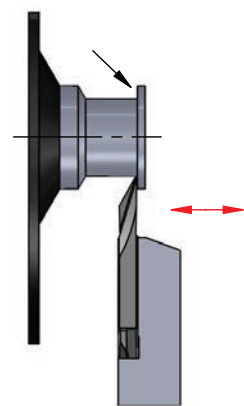

"HINTEN" kopieren

Wiper-Geometrie

Durch Einsatz einer Schneide mit Wipergeometrie kann der Vorschub bis zum doppelten im Gegensatz zu einer Schneide mit normalem Eckenradius erhöht werden.

Durch die spezielle Geometrie der Schneide kann eine geringere Rautiefe trotz höherem Vorschub erreicht werden.

Wiper geometry

By using the insert with wiper geometry the feed rate can be increased up to double time in contrast to an insert with standard radius.

The special geometry improves the surface quality by using a higher feed rate.

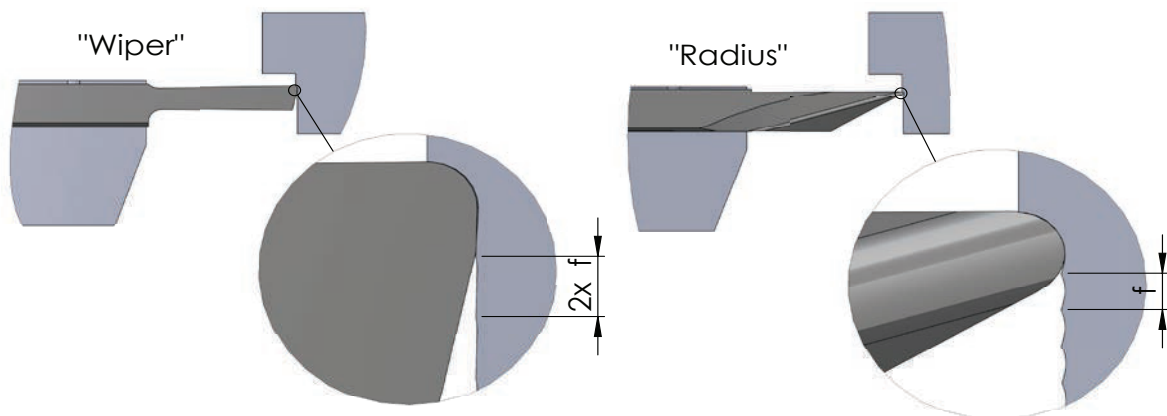

SWISSLINE

Miniaturaußenbearbeitung,
zweischneidig

miniature external machining,
two-cutting edges

Technische Hinweise

Allgemeine Informationen zum
Gewindeschneiden

Technical instructions,
General informations about threading

Empfohlene Anzahl der Schnitte

Die Anzahl der Schnitte ist nur ein Richtwert für das Gewindedrehen. Um eine möglichst lange Standzeit der Schneide zu erreichen beachten Sie bitte die Erklärungen für die Zustellung.
Leerschnitte zum Fertigschneiden sind in dieser Tabelle nicht berücksichtigt.

Recommended number of passes

The number of passes is only a recommendation for threading. To reach a good tool life you have to mention the explanation for the infeed.
Finishing passes are not considered in that chart.



		Stahl (Festigkeit N/mm ²) Steel (N/mm ² tensile strength)					rostfreier Stahl stainless steel	Guss cast iron	Alumini- um alumini- um
		400-500	500-700	700-850	850-1150	>1150			
V m/min		160	140	120	90	70	90	100	300
Steigung P Pitch P		Anzahl der Schnitte number of passes							
mm	Gg/" TPI								
0,25 - 0,35	80/72	3 - 5	3 - 5	3 - 5	3 - 5	3 - 5	3 - 5	3 - 5	3 - 5
0,4	64	3 - 5	3 - 5	4 - 6	4 - 6	4 - 6	4 - 6	4 - 6	3 - 6
0,45	56	3 - 6	3 - 5	4 - 6	5 - 7	5 - 7	5 - 7	4 - 6	3 - 7
0,5	48/44	5 - 8	5 - 8	6 - 9	7 - 10	7 - 10	7 - 10	6 - 9	3 - 8
0,75	40/36	7 - 9	7 - 9	8 - 10	9 - 11	9 - 11	9 - 11	8 - 10	4 - 9
0,8	32	7 - 10	7 - 10	8 - 11	10 - 12	10 - 12	10 - 12	8 - 11	5 - 10
1	28/24	8 - 12	9 - 13	10 - 14	11 - 15	12 - 15	12 - 15	10 - 14	6 - 11
1,25	20/19	10 - 15	11 - 16	12 - 17	14 - 18	15 - 18	15 - 18	12 - 17	7 - 14
1,5	18/16	11 - 18	12 - 19	15 - 20	16 - 21	18 - 22	18 - 22	15 - 20	8 - 16
1,75	14	12 - 20	13 - 21	15 - 22	18 - 23	20 - 24	20 - 24	15 - 22	8 - 16
2-2,5	13/11	15 - 24	16 - 25	18 - 26	20 - 27	22 - 28	22 - 28	18 - 26	17- 22

SWISSLINE

Miniatöraußenbearbeitung,
zweischneidig

miniature external machining,
two-cutting edges

Technische Hinweise

Allgemeine Informationen zum
Gewindeschneiden

Technical instructions,
General informations about threading

Vorschubrichtung

Mit jedem Schneideinsatz für das Gewindedrehen kann sowohl ein Rechts- wie auch ein Linksgewinde geschnitten werden. Hierbei ist folgende Vorschubrichtung zu beachten:

Feed direction

Every insert can be used for right- and lefthand thread. You only have to consider the following feed direction:

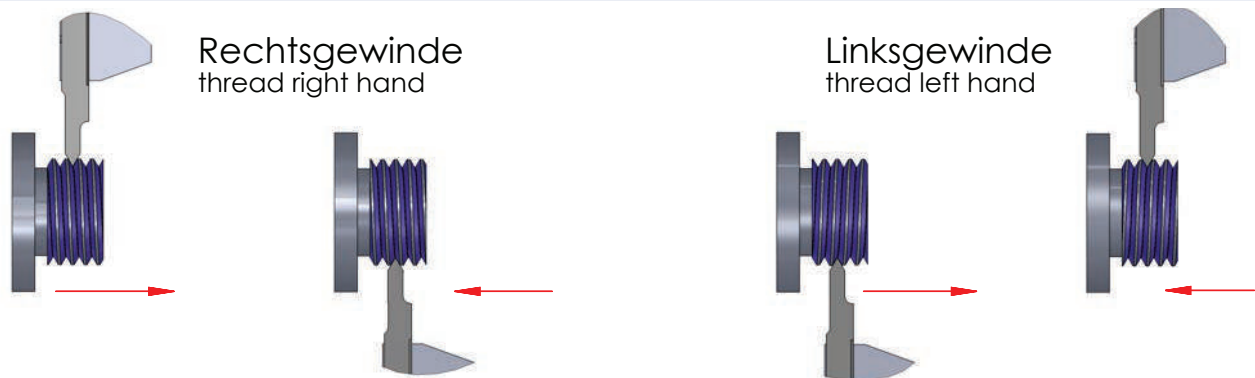

Zustellungsvarianten

Radiale Zustellung	wechselnde Flankenzustellung	einseitige Flankenzustellung
Die meist verwendete Methode um Gewinde herzustellen. Beide Schneiden sind gleichzeitig im Eingriff.	Die Schneiden werden wechselnd eingesetzt.	Nur eine Schneide wird für die komplette Gewindeerstellung eingesetzt.
Problematische Spanbildung, dadurch hohe Schnittkräfte und Verschleiß am Werkzeug und Bauteil.	Reduzierung des Schnittdrucks, höhere Standzeit und bessere Spanbildung.	Reduzierung des Schnittdrucks und bessere Spanbildung, aber einseitige Abnutzung des Werkzeugs.

Infeed possibilities

Radial infeed	alternating flank infeed	flank infeed
The most used method for threading, both sides are at the same time in process.	The flanks are alternating used.	Only one cutting edge is used for the complete thread.
Problematic chip education, high cutting force and weariness at insert and work piece.	Reduced cutting force, higher state time and chip education.	Reduced cutting force and better chip education, but one-sided weariness.

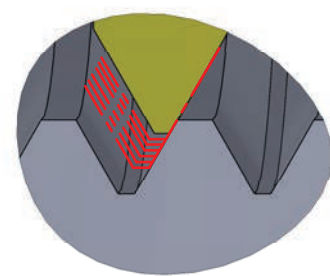
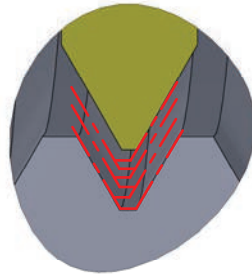
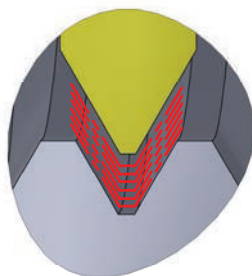

SWISSLINE

Miniaturaußenbearbeitung,
zweischneidig

miniature external machining,
two-cutting edges

Technische Hinweise

Hartmetallsorten und Beschichtungen

Technical instructions,
carbide grades and coatings

K10F

Universell einsetzbares Feinkornhartmetall mit guter Verschleißfestigkeit. Unbeschichtet geeignet für Anwendungen mit niedrigen und mittleren Schnittgeschwindigkeiten, sowie die Bearbeitung von Nicht-eisenmetallen.

All purpose micrograin carbide with good abrasion resistance. Uncoated for applications with low or medium cutting speeds and machining of non-ferrous materials.

CBN

Zähe CBN-Sorte für Anwendungen mit niedrigen Schnittgeschwindigkeiten. Geeignet für gehärtete Stähle, unterbrochene Schnitte und Grauguss.

Ductile CBN grade for applications with lower cutting speed. Suitable for hardened steel, interrupted cuts and cast iron.

CN45F

Universell einsetzbare PVD-TiN-Beschichtung. Diese Allround-Sorte ist für niedrige und mittlere Schnittgeschwindigkeiten mit Einschränkung bei NE-Metallen

PVD-TiN coating - all purpose, all around grade is suitable for low and medium cutting speed with restrictions on non-ferrous materials.

AL41F

Sehr universell einsetzbare TiAlN-Beschichtung mit hoher Temperaturbeständigkeit bei hoher Härte. Sehr gut geeignet auch für NE-Metalle.

TiAlN coating - very universal with a high resistance to high temperature and hardness. Very suitable also for non-ferrous metals.

PD2F

Beschichtung für den universellen Einsatz bei niedrigen und mittleren Schnittgeschwindigkeiten.

Coating for universal use with medium and low speed.

XC2A

Beschichtung mit einer excellenten Warmhärte, Oxidationsbeständigkeit und thermischen Isolationsfähigkeit. Ideal für Hartzerspannung >60HRC

Coating with excellent hot hardness, high oxidation resistance and thermal insulation capacity. Perfect for hard machining >60 HRC.



SWISSLINE

Miniaturaußenbearbeitung,
zweischneidig

miniature external machining,
two-cutting edges

Technische Hinweise

Hartmetallsorten und Beschichtungen

Technical instructions,
carbide grades and coatings

P01C

Beschichtung für die Bearbeitung in zähen Materialien bei niedrigen und mittleren Schnittgeschwindigkeiten.

Coating for the processing in tough material with medium or low cutting speed

P03C

Beschichtung für die Bearbeitung von schwer zerspanbaren Materialien. Sehr gut auch für die Trockenbearbeitung geeignet.

Coating for materials which are difficult to machine. Perfect to use for dry machining.

P07C

Beschichtung für die Bearbeitung von Titan, Edelstahl und Molybdän.

Coating to machine titanium, stainless steel and molybdenum.

P18C

Universell einsetzbare Hochleistungsschicht mit hoher Oxidationsbeständigkeit, Verschleißfestigkeit und Warmhärte.

Very universal high performance coating with high oxidation resistance, wear resistance and hot hardness resistance.

NEME

Beschichtung für die Bearbeitung von Aluminium, Al-Legierungen, NE-Metallen und Composite-Werkstoffen.

Coating for machining aluminium, alloys, non-ferrous metals and composite materials.



SWISSLINE

Miniatúraußenbearbeitung,
zweischneidig

miniature external machining,
two-cutting edges

Technische Hinweise

Schnittdaten

Technical instructions,
cutting data



	Werkstoff	Festigkeit	Werkstoff-Nr	Werkstoffbezeichnung	Werkstoff-Nr
P	Allgemeiner Baustahl	< 800 N/mm2	1.0037	St37-2	1.0570
	Automatenstahl	< 800 N/mm2	1.0718	9SMnPb28	1.0727
	Einsatzstahl unlegiert	< 800 N/mm2	1.0401	C15	1.0481
	Einsatzstahl legiert	< 1000 N/mm2	1.7331	16MnCr5 (EC80)	1.7015
	Vergütungsstahl unlegiert	< 850 N/mm2	1.0503	C45	1.1191
	Vergütungsstahl unlegiert	< 1000 N/mm2	1.0601	C60	1.1221
	Vergütungsstahl legiert	< 800 N/mm2	1.5131	50MnSi4	1.7030
	Vergütungsstahl legiert	< 1300 N/mm2	1.5755	31NiCr14	1.7033
	Stahlguss	< 850 N/mm2	0.9650	G-X260Cr27	1.6750
	Nitrierstahl	< 1000 N/mm2	1.8504	34CrAl6	1.8507
	Nitrierstahl	< 1200 N/mm2	1.8515	31CrMo12	1.8523
	Wälzlagerstahl	< 1200 N/mm2	1.3505	100Cr6 (W3)	1.3543
	Federstahl	< 1200 N/mm2	1.5026	55Si7	1.7176
	Schnellarbeitsstahl	< 1300 N/mm2	1.3344	S 6-5-3	1.3255
	M	Werkzeugstahl für Kaltarbeit	< 1300 N/mm2	1.2312	40CrMnMoS8 6
Werkzeugstahl für Warmbeit		< 1300 N/mm2	1.2343	X38CrMoV 5 1	1.2767
Stahl und Stahlguss rostfrei geschwefelt		< 850 N/mm2	1.4305	X8CrNiS18 9	1.4105
Nichtrostender Stahl, ferritisch		< 750 N/mm2	1.4510	X3CrTi17	1.4528
Nichtrostender Stahl, martensitisch		< 900 N/mm2	1.4034	X46Cr13	1.4116
Nichtrost. Stahl, ferritisch/martensit.		<1100 N/mm2	1.4313	X3CrNi13-4	1.4028
Nichtrost. Stahl, austenitisch/ferritisch		< 850 N/mm2	1.4460	X8CrNiMo27 5	1.4821
Nichtrostender Stahl, austenitisch		< 750 N/mm2	1.4301	X5CrNi18-10	1.4571
K	Hitzebeständig	< 1100 N/mm2	1.4747	X80CrNiSi20	1.4876
	Grauguss mit Lammellengraphit	100-350N/mm2	0.6010	GG10	0.6025
	Grauguss mit Lammellengraphit	300-1000N/mm2	0.6030	GG30	0.6045
	Kugelgraphitguss	300-500N/mm2	0.7040	GGG40	0.7050
	Kugelgraphitguss	550-800N/mm2	0.7060	GGG60	0.7080
	Temperguss weis	350-450N/mm2	0.8035	GTW35	0.8045
	Temperguss weis	500-650N/mm2	0.8055	GTW55	0.8065
	Temperguss schwarz	350-450N/mm2	0.8135	GTS35	0.8145
N	Temperguss schwarz	500-700N/mm2	0.8155	GTS55	0.8170
	Aluminium (unlegiert, niedrig legiert)	< 350 N/mm2	3.0255	Al99,5	3.3308
	Aluminiumlegierungen < 0,5% Si	< 500 N/mm2	3.0515	AlMn1	3.1355
	Aluminiumlegierungen 0,5-10% Si	< 400 N/mm2	3.2152	GD-AlSi6Cu4	3.2373
	Aluminiumlegierungen 10-15% Si	< 400 N/mm2	3.2381	G-AlSi10Mg	3.5562
	Aluminiumlegierungen > 15% Si	< 400 N/mm2		G-AlSi17Cu4	
	Kupfer (unlegiert, niedrig legiert)	< 350 N/mm2	2.0060	E-Cu57	2.0090
	Kupfer-Knetlegierungen	< 700 N/mm2	2.0240	CuZn15	2.0265
	Kupfer-Sonderlegierungen	< 200 HB	2.0916	CuAl5	2.1525
	Kupfer-Sonderlegierungen	< 300HB	2.0978	CuAl11Ni6Fe5	
	Kupfer-Sonderlegierungen	> 300 HB	2.1247	CuBe2F125	
	Messing kurzspanend, Bronze, Rotguss	< 600 N/mm2	2.0360	CuZn40 (Ms60)	2.0380
	Messing langspanend	< 600 N/mm2	2.0335	CuZn36 (Ms63)	2.1293
	Thermoplaste			Delrin, Hostalen	
	Duroplaste			Ferrozell, Bakelit	
	Faserverstärkte Kunststoffe			GFK (Glasfaserverstärkt)	
	Magnesium und Magnesiumlegierungen	< 850 N/mm2	3.5200	M2, MgMn2	3.5612
	Graphit			C8000, R8500X	
Wolfram und Wolframlegierungen			W-NiFe (Densimet W)		
Molybdän und Molybdänlegierungen			Mo , Mo-50Re		
S	Reinnickel		1.3911	RNi24	1.3927
	Nickellegierungen		1.3912	Ni36 (Invar)	1.3924
	Nickellegierungen	< 850 N/mm2	2.4360	S-NiCu 30 Fe	
	Nickel-Chromlegierungen		2.4886	SG-NiMo16Cr16W	2.4610
	Nickel- und Kobaltlegierungen	< 1300 N/mm2	2.4632	NiCr20Co18Ti	2.4631
	Nickel- und Kobaltlegierungen	< 1300 N/mm2	2.4634	NiCo20Cr15MoAlTi	2.4654
	Hochwarmfeste Legierungen	< 1300 N/mm2		Hardox 400	1.4939
	Nickel-Kobalt-(Chrom-)legierungen	< 1400 N/mm2	2.4806	SG-NiCr20Nb, Inconel 82	2.4851
	Reintitan	< 900 N/mm2	3.7025	Ti99,8	3.7034
	Titanlegierungen	< 700 N/mm2	3.7114	TiAl5Sn2	3.7174
	Titanlegierungen	< 1200 N/mm2	3.7164	TiAl5V4	3.7144
H	Stahl gehärtet	< 45 HRc			
		46-55HRc			
		56-60 HRc			
		61-65 HRc			
		65-70 HRc			

SWISSLINE

Miniaturaußenbearbeitung,
zweischneidig

miniature external machining,
two-cutting edges

Technische Hinweise

Schnittdaten

Technical instructions,
cutting data



Werkstoffbezeichnung	Werkstoff-Nr	Werkstoffbezeichnung	Vc K10F (m/min.)	Vc P18C (m/min.)	Bearbeitung	ap (mm)	f (mm/U)
St52-3	1.0060	St60-2	50-120	100-240	▼ ▼▼ ▼▼▼	< 4 < 2,5 < 1,5	0,1-0,25 0,02-0,15 0,005-0,08
45S20	1.0757	46SPb2	50-120	100-240			
17Mn4	1.1141	C15E (CK15)	50-120	100-240			
13Cr3 (EC60)	1.5919	15CrNi6	60-120	80-220			
Ck45	1.0535	C55	60-120	80-220			
Ck60	1.0540	C50	60-120	80-220			
28Cr4	1.7225	42CrMo4	60-120	80-220			
34Cr4	1.3565	48CrMo4	60-120	80-220			
GS-20NiCrMo3 7	1.6582	GS-34 CrNiMo 6	60-120	80-220			
34AlMo5	1.8509	41CrAlMo7	40-100	80-200			
39CrMoV19 3	1.8550	34 CrAlNi 7	40-100	80-200			
X192CrMo17	1.3520	100 CrMn 6 (W4)	40-100	80-200			
55Cr3	1.7701	51CrMoV4		50-120			
S 18-1-2-5	1.3294	PMH56-5-3-8; ASP30		50-120			
X155CrVMo12 1	1.2316	X38CrMo16; RAMAX		40-100			
X45NiCrMo4	1.2842	90MnCrV8		40-100			
X4CrMoS18	1.4107	GX8CrNi12	40-80	80-180			
X105CrCoMo18 2	1.4016	X6Cr17	40-80	80-180			
X50CrMoV15	1.4106	X2CrMoSi18-2-1	40-80	80-180			
X30Cr13	1.4104	X14CrMoS17	30-65	50-100			
X20CrNiSi25 4	1.4462	X2CrNiMoN22-5-3 (Duplex)	30-65	50-100			
X6CrNiMoTi17 12 2	1.4449	X3CrNiMo18-12-3	30-65	50-100			
X10NiCrAlTi32-21	1.4825	GX25CrNiSi18-9	30-65	50-100			
GG25			30-110	30-180			
GG45			30-90	30-150			
GGG50			25-110	30-180			
GGG80			25-80	30-120			
GTW45			20-40	30-90			
GTW65			20-40	20-80			
GTS45			20-40	30-90			
GTS70			20-40	20-80			
A199,9Mg0,5	3.0256	E-Al H	120-500	120-600			
AlCuMg2	3.3315	AlMg1	120-500	120-600			
GD-AlSi9Mg	3.2134	GD-AlSi5Cu1Mg	100-400	100-450			
G-MgAl6	3.2525	S-AlSi12	70-250	70-300			
G-AlSi25CuNiMg		G-AlSi21CuNiMg	60-140	60-150			
SF-Cu	2.1522	CuSi2Mn	60-140	60-150			
CuZn30	2.0321	CuZn37	100-160	100-180			
CuSi3Mn		Ampco 8-16	90-160	90-180			
		Ampco18-26	80-160	80-180			
		Ampco M-4	80-160	80-180			
CuZn39Pb2 (Ms58)	2.0410	CuZn44Pb2	120-200	120-220			
CuCrZr	2.1080	CuSn6Zn6	70-140	70-150			
Makrolon, Novodur		Acrylglas, Polystyrol	80-160	80-180			
Pertinax		Resopal	80-160	80-180			
CFK (Kohlefaserverstärkt)		AFK (Amidfaserverstärkt)		80-180			
MgAl6Zn1	3.5812	MgAl8Zn1		80-180			
R8650		Technograph15		80-180			
W-Cu80/20		W93NiFe (DENAL)		80-180			
TZC, TZM		MHC, ODS		80-180			
RNi8	1.3926	RNi12		30-80			
Ni54	1.3921	Ni49		18-75			
NiCu 30 Fe		Monel 400		18-75			
NiMo16Cr16Ti		Hastelloy C-276		18-40			
NiCr20TiAl		Nimonic 80		18-40			
NiCr19Co14Mo4Ti		Waspaloy		18-40			
X12CrNiMo12	1.4980	X6NiCrTiMoVB25-15-2		15-30			
NiCr23Fe, Inconel 601	2.4667	SG-NiCr19NbMoTi		15-30			
Ti99,7	3.7064	Ti99,5		15-30			
TiAl6V6Sn2	3.7124	TiCu2		100-150			
TiAl6Sn2Zr4Mo2	3.7154	TiAl6Zr5		100-150			



f: (mm/U) ≙ (mm/Rev.)

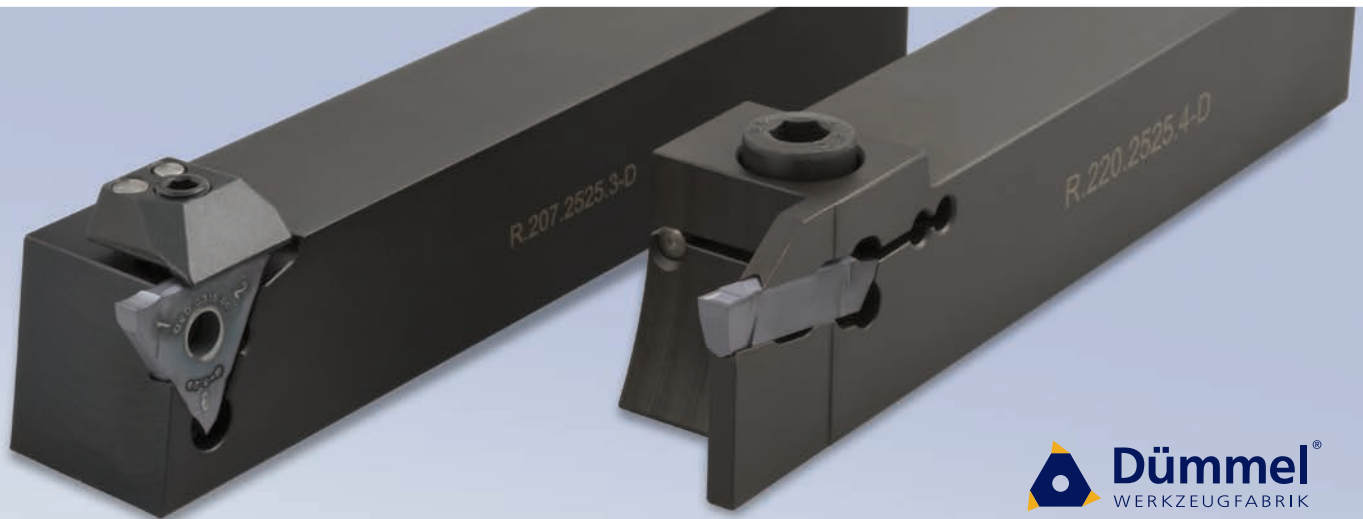

STECHDREH-WERKZEUGE



SYSTEM DED: Einstechen dreischneidig
SYSTEM ZTP: Einstechen zweischneidig

system DED: grooving with three-cutting edges
system ZTP: grooving with two-cutting edges

SYSTEM DED

Einstecken mit dreischneidigen Wendeplatten

grooving with three-cutting edges indexable inserts

Übersicht

summary

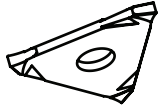

Allgemeine Beschreibung

general instructions

... 236

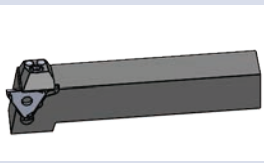

Klemmhalter

toolholder

**Maße
dimensions**

**Seite
page**

Typ .207

Klemmhalter,
Außenbearbeitung

toolholder,
external application

Spannbereich
holding capacity
S 0.5 - 6.5 mm
t max. 4 / 6

... 237

Typ .0.780

Klemmhalter,
Außenbearbeitung

toolholder,
external application

Spannbereich
holding capacity
S 1.9 - 6.5 mm
t max. 8

... 239

Typ .0.738

Klemmhalter, gekröpft
Außenbearbeitung

toolholder, cranked,
external application

Spannbereich
holding capacity
S 0.5 - 6.5 mm
t max. 6

... 240

Typ .0.618

Klemmhalter,
für Eckenfreistriche,
Außenbearbeitung

toolholder,
for corner reliefs,
external application

Spannbereich
holding capacity
S 1.9 - 6.5 mm

... 241

Typ .0.660

Bohrstange,
Innenbearbeitung

grooving boring bar,
internal application

Spannbereich
holding capacity
S 0.5 - 6.5 mm
D min. 46

... 242

Typ .0.736

Klemmhalter,
zum Abstechen,
Außenbearbeitung

toolholder,
for parting off,
external application

Stechbreite
width of groove
S 0.5 - 1.2 mm
t max. 8

... 243

SYSTEM DED

Einstecken mit dreischneidigen Wendeplatten

grooving with three-cutting edges indexable inserts

Übersicht

summary



Wendeschneidplatten Stechdrehen

indexable inserts grooving

Maße dimensions

Seite page

Typ Stechdrehen	für Sicherungsringe DIN 471/472 und Stechdrehen allgemein	type grooving for circlips DIN 471/472 and general grooving	Stechbreite width of groove S 0.57 - 5.29 mm	... 244
Typ Stechdrehen	für unterbrochene Schnitte und Sicherungsringe DIN 471/472	type grooving interrupted cuts, and circlips DIN 471/472	Stechbreite width of groove S 1.07 - 5.29 mm	... 246
Typ Stechdrehen	für Sicherungsringe DIN 471/472, stabile Ausführung	type grooving for circlips DIN 471/472, solid construction	Stechbreite width of groove C 0.55 - 1.05 mm	... 247
Typ Stechdrehen	für Sicherungsringe DIN 471/472, mit Nutaußenkantenfasung	type grooving for circlips DIN 471/472, with chamfer	Stechbreite width of groove C 1.24 - 5.29 mm	... 248
Typ Stechdrehen	zum Feindreihen	type grooving for finishing	Stechbreite width of groove S 1.0 - 4.0 mm	... 250
Typ Stechdrehen	Vollradius, für Nuten und Eckenfreistich	type grooving full radius, for grooving and corner reliefs	Stechbreite width of groove S 0.5 - 5.0 mm	... 251
Typ Stechdrehen	mit Spanformer, zum Abstechen	type grooving with chipformer for parting off	Stechbreite width of groove S 1.99 - 2.79 mm	... 252
Typ Stechdrehen	ohne Spanformer, zum Abstechen	type grooving without chipformer for parting off	Stechbreite width of groove S 0.5 - 1.4 mm	... 253
Typ Stechdrehen	zum Einstecken und Längsdrehen	type grooving for grooving and turning	Stechbreite width of groove C 3.29 mm t max. 3.5	... 254
Typ Stechdrehen	für Eckenfreistich, ähnlich DIN 509 Form F	type grooving for corner reliefs, similar to DIN 509 type F	Stechbreite width of groove S 2.4 - 5.0 mm	... 255
Typ Stechdrehen	Axialbearbeitung	type grooving, face grooving	Stechbreite width of groove C 1.5 - 5.0 mm t max. 3.5	... 256



SYSTEM DED

Einstecken mit dreischneidigen Wendeplatten

grooving with three-cutting edges indexable inserts

Übersicht

summary



Sets System DED

Halter (Rechte Ausführung) und Schneiden

sets system DED

toolholder (righthand version) and inserts

Maße dimensions

Seite page

SET-DED 1

- für Sicherungsringe DIN 471 / 472 und Stechdrehen allgemein

- for circlips DIN 471 / 472 and general grooving

Stechbreite width of groove S 0.57 - 1.99 mm

... 257

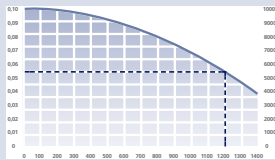
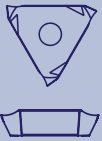

Technische Hinweise

Technical Instructions

Seite page

Hartmetallsorten und Beschichtungen

carbide grades and coatings

... 273

Schnittdaten

cutting data

... 275

SYSTEM ZTP

Einstecken mit
zweischneidigen Wendeplatten

grooving with two-cutting
edges indexable inserts

Übersicht

summary

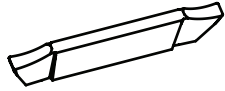

Allgemeine Beschreibung

general instructions

... 259

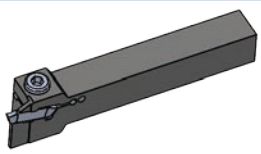

Klemmhalter

toolholder

**Maße
dimensions**

**Seite
page**

Typ .212

Klemmhalter,
Außenbearbeitung

toolholder,
external application

Spannbereich
holding capacity
S 2.0 - 6.0 mm
t max. 12

... 260

Typ .220

Klemmhalter,
Außenbearbeitung

toolholder,
external application

Spannbereich
holding capacity
S 2.0 - 6.0 mm
t max. 20

... 261

Typ .225

Klemmhalter,
Außenbearbeitung

toolholder,
external application

Spannbereich
holding capacity
S 2.0 - 6.0 mm
t max. 25

... 262

Typ .0.428

Bohrstange,
Innenbearbeitung

grooving boring bar,
internal application

Spannbereich
holding capacity
S 2.0 - 6.0 mm
t max. 15

... 263

Typ .280

Klemmhalter,
Axialbearbeitung

toolholder,
face grooving

Spannbereich
holding capacity
S 4.0 - 6.0 mm
t max. 8

... 264

Typ .281

Klemmhalter,
Axialbearbeitung

toolholder,
face grooving

Spannbereich
holding capacity
S 4.0 - 6.0 mm
t max. 8.5

... 265



SYSTEM ZTP

Einstecken mit
zweischneidigen Wendeplatten

grooving with two-cutting
edges indexable inserts

Übersicht

summary

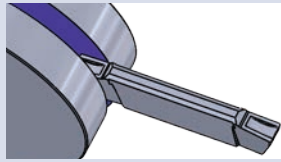

**Wendeschneidplatten
Stechdrehen**

**indexable inserts
grooving**

**Maße
dimensions**

**Seite
page**

Typ Stechdrehen10	mit runder Spannutt	type grooving, with round chipbreaker	Stechbreite width of groove S 2.0 - 6.0 mm	... 266
Typ Stechdrehen20	mit ebener Spanfläche	type grooving, with flat chipbreaker	Stechbreite width of groove S 2.0 - 6.0 mm	... 267
Typ Stechdrehen30	mit Spanformer	type grooving, with chipformer	Stechbreite width of groove S 2.0 - 6.0 mm	... 268
Typ Stechdrehen ZTPR	mit Vollradius, und runder Spannutt	type grooving, with full radius and round chipbreaker	Stechbreite width of groove S 2.0 - 6.0 mm	... 269
Typ Stechdrehen / Abstechen	mit Spanformer	type grooving, with chipformer, for parting off	Stechbreite width of groove S 2.0 - 4.0 mm	... 270
Typ Stechdrehen / Längsdrehen	mit Spanformer	type grooving, with chipformer, grooving and turning	Stechbreite width of groove S 3.0 - 6.0 mm	... 271
Typ Stechdrehen / Axialbearbeitung	mit Spanformer	type grooving, with chipformer, face grooving	D min. 40 Stechbreite width of groove S 4.0 - 6.0 mm,	... 272

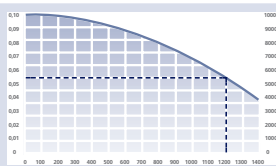

Technische Hinweise

Technical Instructions

**Seite
page**

Hartmetallsorten und Beschichtungen carbide grades and coatings **... 273**

Schnittdaten cutting data **... 275**

SYSTEM DED

Einstecken mit
dreischneidigen Wendeplatten

grooving with three-cutting
edges indexable inserts

Allgemeine Beschreibung

general instruction



System DED:

Das bewährte System zum Einstecken und Abstecken ab 0.5 mm Breite.

System DED:

Proven system for grooving and turning off from a width of 0.5 mm starting.

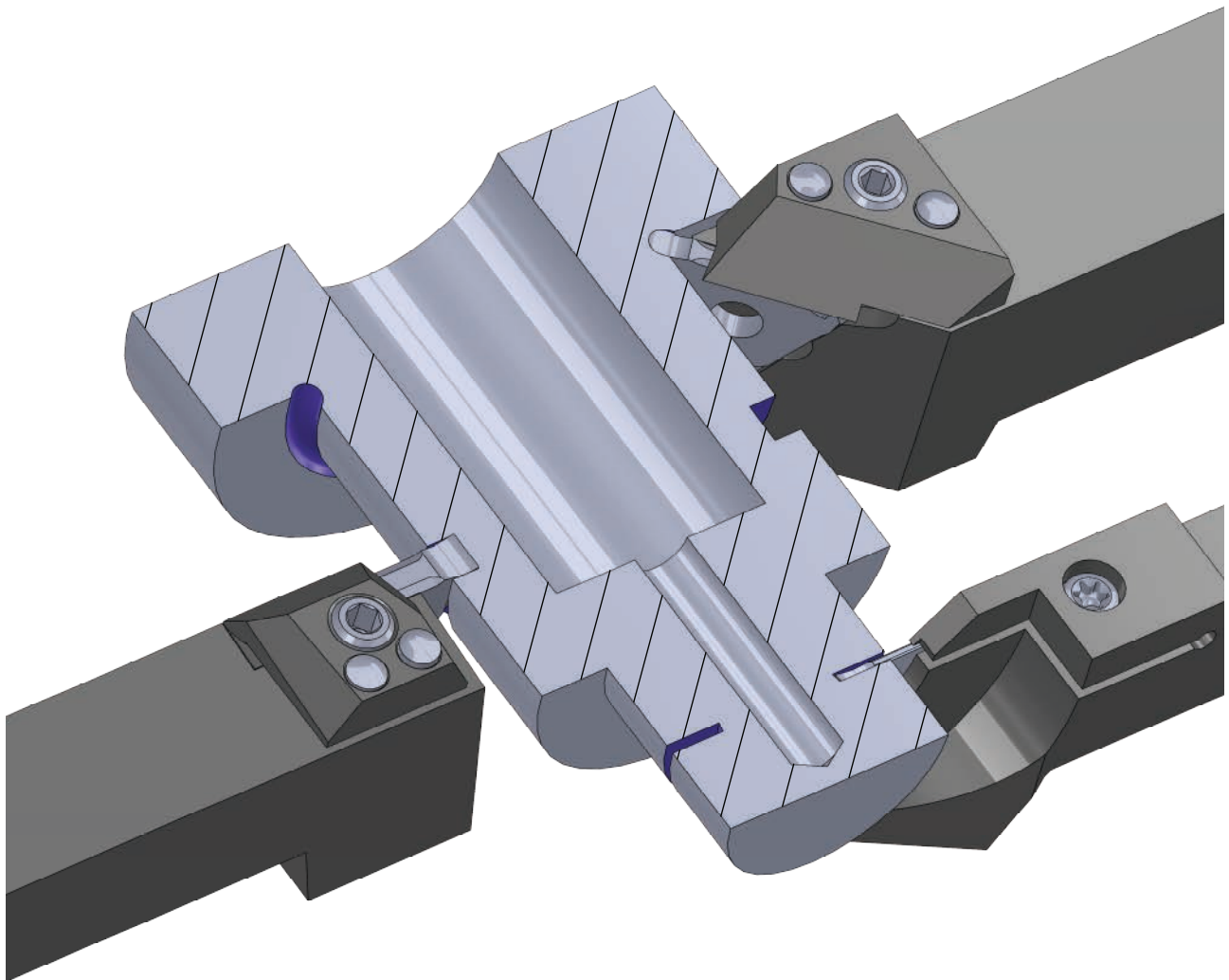

SYSTEM DED

Einstecken mit dreischneidigen Wendepplatten

grooving with three-cutting edges indexable inserts

Typ .207

Klemmhalter, Außenbearbeitung

toolholder, external application

Stechtiefe t max. 6 mm
Spannbereich S 0.5 - 6.5 mm

depth of groove t max. 6 mm
holding capacity S 0.5 - 6.5 mm

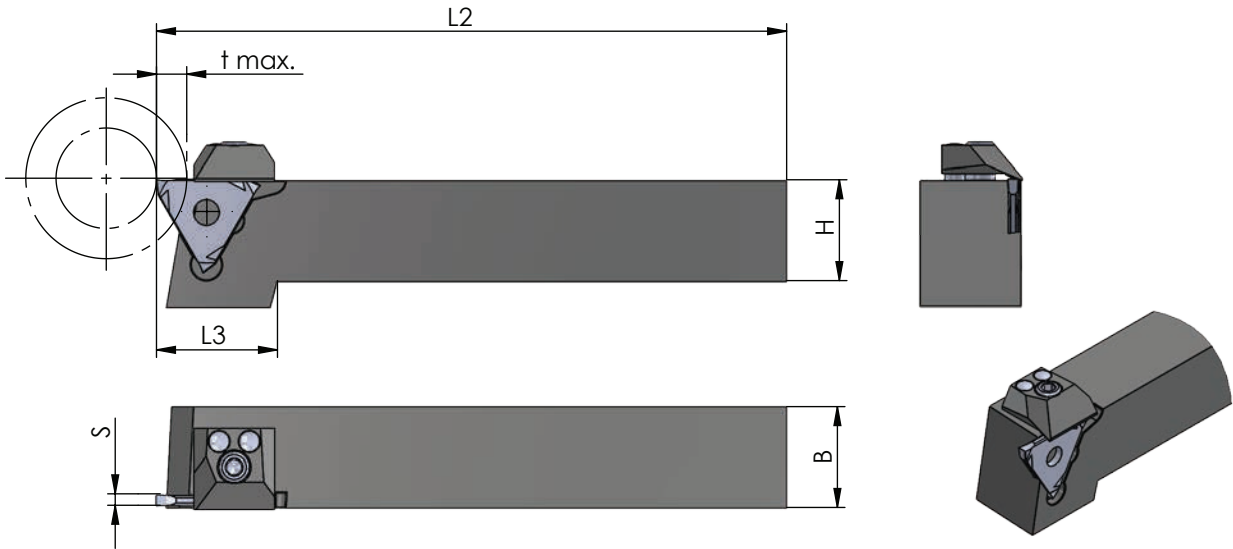

Rechts (R): wie gezeichnet
Links (L): spiegelbildlich

righthand (R): as shown
lefthand version (L): mirror image

Abmessungen in mm

dimensions in mm

Bestellnummer part number	H	B	H x B (inch)	*t max.	L2	L3	Spannpratze claw	Spannschraube screw	Führungsstifte guide pin	Spannbereich S holding capacity S	Wende- schneidplatte S indexable insert S
R/L .207.1212.1-D	12	12		4	100	28	R.207. ... : PD21/R L.207. ... : PD21/L	ZT200	6325	0.5 - 2.0	
R/L .207.1616.1-D	16	16		4	125	26					
R/L .207.2020.1-D	20	20		4	125	23					
R/L .207.2525.1-D	25	25		4	150	-					
R/L .207.U.1000.1-D	25.4	25.4	1"x1"	4	150	-					
R/L .207.3232.1-D	32	32		4	170	-				1.9 - 3.0	
R/L .207.1212.2-D	12	12		6	100	28					
R/L .207.1616.2-D	16	16		6	125	26					
R/L .207.2020.2-D	20	20		6	125	23					
R/L .207.2525.2-D	25	25		6	150	-					
R/L .207.3232.2-D	32	32		6	170	-					
↳ ...											

*tmax. reduziert bei Werkstück Ø > 40
*tmax. reduced for workpiece Ø > 40

Spitzenhöhe JS14

center height JS14

Bestellbeispiel:
für rechte Ausführung
R.207.1212.1-D

order-example:
righthand version
R.207.1212.1-D

SYSTEM DED

Einstecken mit dreischneidigen Wendeplatten

grooving with three-cutting edges indexable inserts

Typ .207

Klemmhalter, Außenbearbeitung

toolholder, external application

Stechtiefe t max. 6 mm
Spannbereich S 0.5 - 6.5 mm

depth of groove t max. 6 mm
holding capacity S 0.5 - 6.5 mm

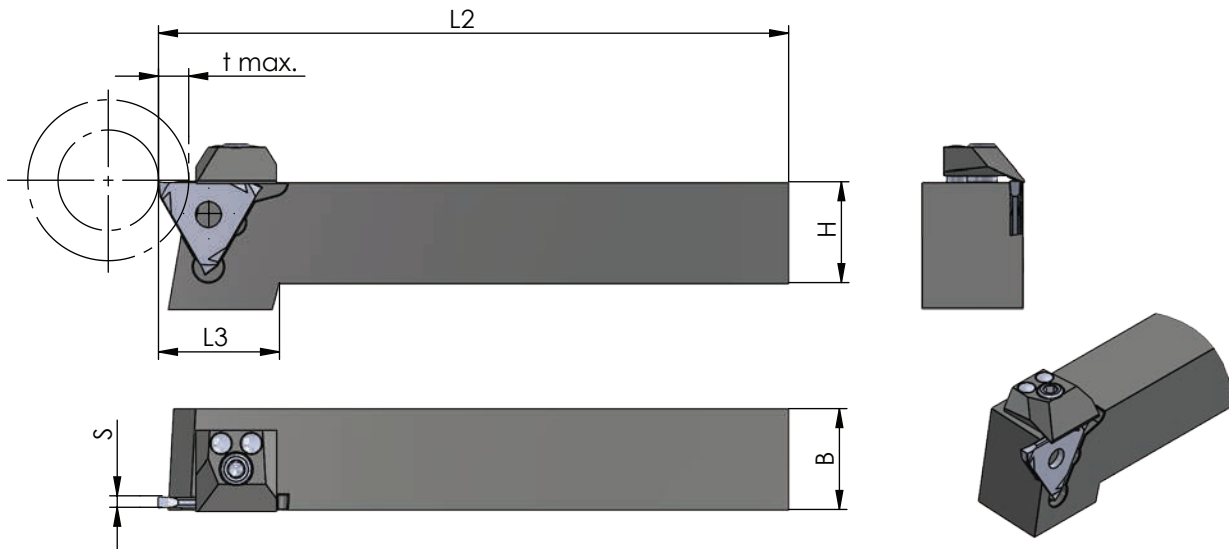

Rechts (R): wie gezeichnet
Links (L): spiegelbildlich

righthand (R): as shown
lefthand version (L): mirror image

Abmessungen in mm

dimensions in mm



Bestellnummer part number	H	B	H x B (inch)	*t max.	L2	L3	Spannpratze claw	Spannschraube screw	Führungsstifte guide pin	Spannbereich S holding capacity S	Wende- schneidplatte S indexable insert S
R/L .207.1212.3-D	12	12		6	100	28					
R/L .207.1616.3-D	16	16		6	125	26					
R/L .207.2020.3-D	20	20		6	125	23		ZT200	6325	2.9 - 4.0	
R/L .207.2525.3-D	25	25		6	150	-	R.207, ... ; PD21/R L.207, ... ; PD21/L				
R/L .207.3232.3-D	32	32		6	170	-					
R/L .207.1616.4-D	16	16		6	125	26					
R/L .207.2020.4-D	20	20		6	125	23					
R/L .207.2525.4-D	25	25		6	150	-	R.207, ... ; PD25/R L.207, ... ; PD25/L	ZT200	6325	3.9 - 6.5	
R/L .207.3232.4-D	32	32		6	170	-					

*tmax. reduziert bei Werkstück Ø > 40
*tmax. reduced for workpiece Ø > 40

Spitzenhöhe JS14

center height JS14

Bestellbeispiel:
für rechte Ausführung
R.207.1212.3-D

order-example:
righthand version
R.207.1212.3-D

SYSTEM DED

Einstecken mit dreischneidigen Wendeplatten

grooving with three-cutting edges indexable inserts

Typ .0.780

Klemmhalter, Außenbearbeitung

toolholder, external application

Stechtiefe t max. 8 mm
Spannbereich S 1.9 - 6.5 mm

depth of groove t max. 8 mm
holding capacity S 1.9 - 6.5 mm

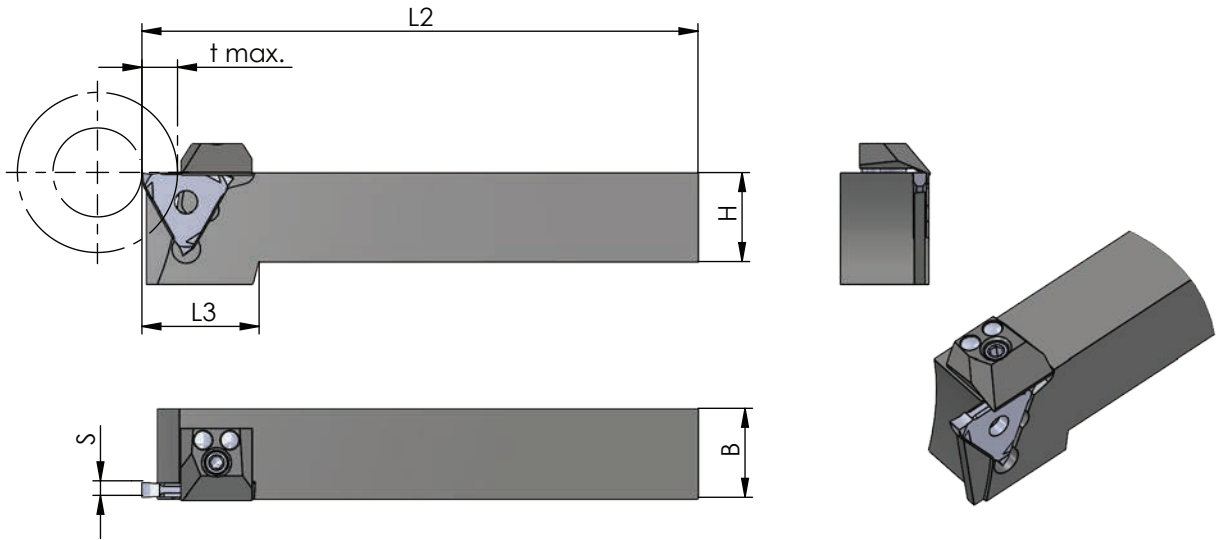

Rechts (R): wie gezeichnet
Links (L): spiegelbildlich

righthand (R): as shown
lefthand version (L): mirror image

Abmessungen in mm

dimensions in mm

Bestellnummer part number	H	B	*t max.	L2	L3	Spannpratze claw	Spannschraube screw	Führungsstifte guide pin	Spannbereich S holding capacity S		Wende- schneidplatte S indexable insert S
									<=		
R/L .0.780.2020.2-D	20	20	8	125	25	R.0.780. ... : PD21/R L.0.780. ... : PD21/L	ZT200	6325	1.9 - 3.0		
R/L .0.780.2525.2-D	25	25	8	150	-				2.9 - 4.0		
R/L .0.780.3232.2-D	32	32	8	170	-				3.9 - 6.5		
R/L .0.780.2020.3-D	20	20	8	125	25	R.0.780. ... : PD25/R L.0.780. ... : PD25/L	ZT200	6325	1.9 - 3.0		
R/L .0.780.2525.3-D	25	25	8	150	-				2.9 - 4.0		
R/L .0.780.3232.3-D	32	32	8	170	-				3.9 - 6.5		
R/L .0.780.2020.4-D	20	20	8	125	25	R.0.780. ... : PD25/R L.0.780. ... : PD25/L	ZT200	6325	1.9 - 3.0		
R/L .0.780.2525.4-D	25	25	8	150	-				2.9 - 4.0		
R/L .0.780.3232.4-D	32	32	8	170	-				3.9 - 6.5		

*tmax. reduziert bei Werkstück Ø > 125
*tmax. reduced for workpiece Ø > 125

Bestellbeispiel:
für rechte Ausführung
R.0.780.2020.2-D

order-example:
righthand version
R.0.780.2020.2-D

SYSTEM DED

Einstecken mit dreischneidigen Wendeplatten

grooving with three-cutting edges indexable inserts

Typ .0.738

Klemmhalter, gekröpft, Außenbearbeitung

toolholder, cranked, external application

Stechtiefe t max. 6 mm
Spannbereich S 0.5 - 6.5 mm

depth of groove t max. 6 mm
holding capacity S 0.5 - 6.5 mm

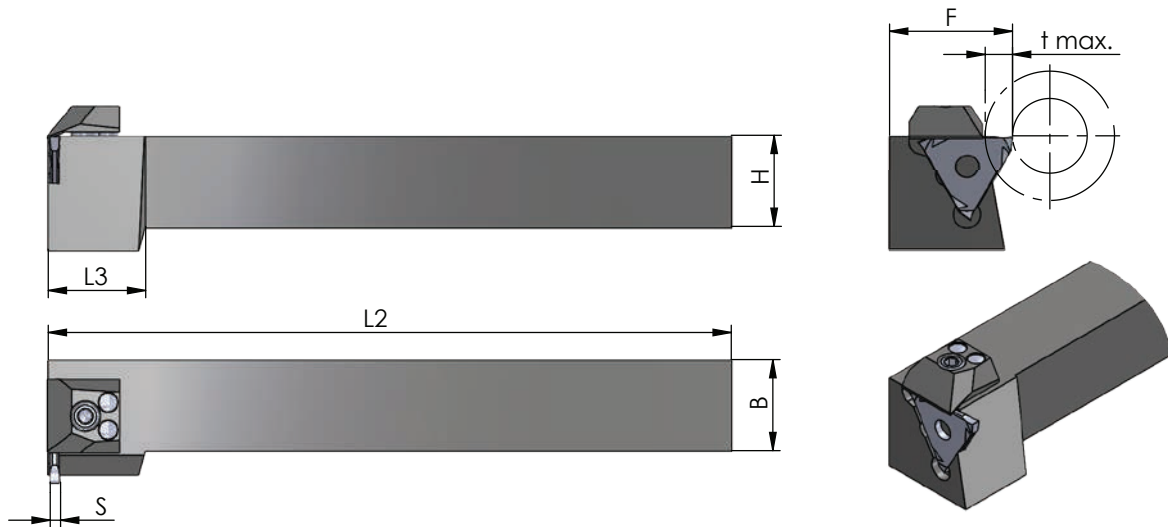

Rechts (R): wie gezeichnet
Links (L): spiegelbildlich

righthand (R): as shown
lefthand version (L): mirror image

Abmessungen in mm

dimensions in mm



Bestellnummer part number	H	B	F	*t max.	L2	L3	Spannpratze claw	Spannschraube screw	Führungsstifte guide pin	Spannbereich S holding capacity S		Wende- schneidplatte S indexable insert S
										<	<	
R/L .0.738.2020.1-D	20	20	27	4	150	20	PD21/L R.0.738. ... ; PD21/R L.0.738. ... ; PD21/R	ZT200	6325	0.5 - 2.0		
R/L .0.738.2525.1-D	25	25	32	4	150	-				1.9 - 3.0		
R/L .0.738.2020.2-D	20	20	27	6	150	20				2.9 - 4.0		
R/L .0.738.2525.2-D	25	25	32	6	150	-				3.9 - 6.5		
R/L .0.738.2020.3-D	20	20	27	6	150	20	PD25/L R.0.738. ... ; PD25/R L.0.738. ... ; PD25/R	ZT200	6325	0.5 - 2.0		
R/L .0.738.2525.3-D	25	25	32	6	150	-				1.9 - 3.0		
R/L .0.738.2020.4-D	20	20	27	6	150	20	PD25/L R.0.738. ... ; PD25/R L.0.738. ... ; PD25/R	ZT200	6325	2.9 - 4.0		
R/L .0.738.2525.4-D	25	25	32	6	150	-				3.9 - 6.5		

*tmax. reduziert bei Werkstück Ø > 40
*tmax. reduced for workpiece Ø > 40

Bestellbeispiel:
für rechte Ausführung
R.0.738.2020.1-D

order-example:
righthand version
R.0.738.2020.1-D

SYSTEM DED

Einstecken mit dreischneidigen Wendeplatten

grooving with three-cutting edges indexable inserts

Typ .0.618

Klemmhalter, für Eckenfreistriche, Außenbearbeitung

toolholder, for corner reliefs, external application

Spannbereich S 1.9 - 6.5 mm

holding capacity S 1.9 - 6.5 mm

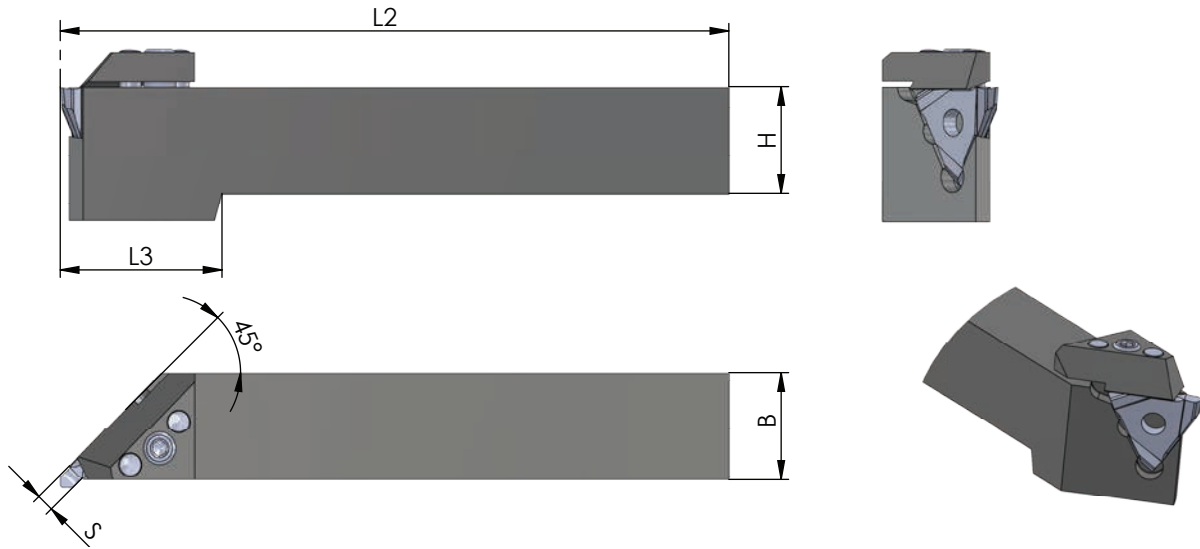

Rechts (R): wie gezeichnet
Links (L): spiegelbildlich

righthand (R): as shown
lefthand version (L): mirror image

Abmessungen in mm

dimensions in mm

Bestellnummer part number	H	B	L2	L3	Spannpratze claw	Spannschraube screw	Führungsstifte guide pin	Spannbereich S holding capacity S	
								≪	Wende- schneidplatte S indexable insert S
R/L .0.618.2020.2-D	20	20	125	30	R.0.618. ... : PD22/R L.0.618. ... : PD22/L	ZT200	6325	1.9 - 3.0	
R/L .0.618.2525.2-D	25	25	150	-				2.9 - 4.0	
R/L .0.618.3232.2-D	32	32	170	-				3.9 - 6.5	
R/L .0.618.2020.3-D	20	20	125	30	R.0.618. ... : PD23/R L.0.618. ... : PD23/L	ZT200	6325	1.9 - 3.0	
R/L .0.618.2525.3-D	25	25	150	-				2.9 - 4.0	
R/L .0.618.3232.3-D	32	32	170	-				3.9 - 6.5	
R/L .0.618.2020.4-D	20	20	125	30	R.0.618. ... : PD23/R L.0.618. ... : PD23/L	ZT200	6325	1.9 - 3.0	
R/L .0.618.2525.4-D	25	25	150	-				2.9 - 4.0	
R/L .0.618.3232.4-D	32	32	170	-				3.9 - 6.5	

Bestellbeispiel:
für rechte Ausführung
R.0.618.2020.2-D

order-example:
righthand version
R.0.618.2020.2-D

SYSTEM DED

Einstecken mit dreischneidigen Wendeplatten

grooving with three-cutting edges indexable inserts

Typ .0.660

Bohrstange, Innenbearbeitung

grooving boring bar, internal application

D min. 46
Spannbereich S 0.5 - 6.5 mm

D min. 46
holding capacity S 0.5 - 6.5 mm

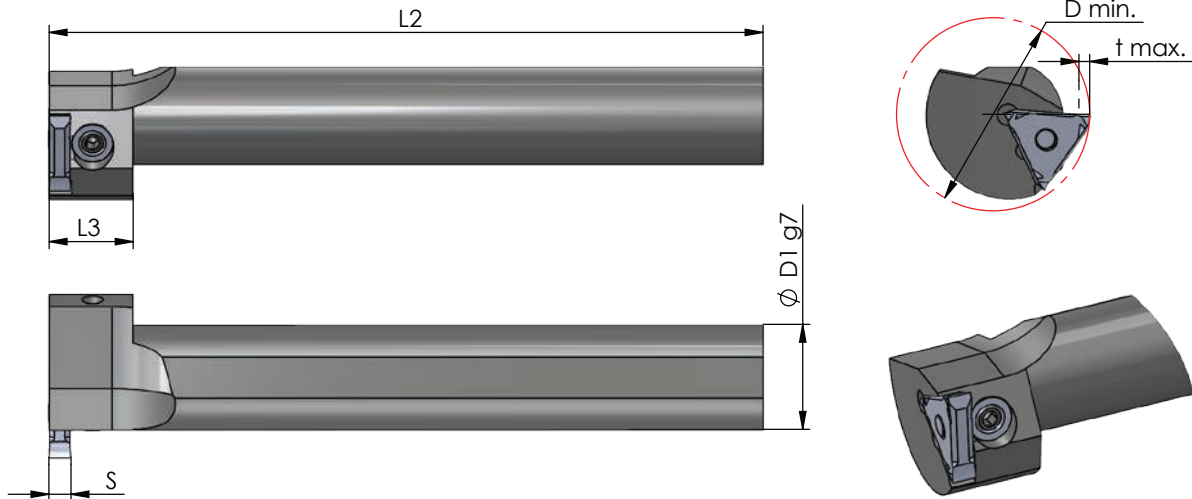

Rechts (R): wie gezeichnet
Links (L): spiegelbildlich

righthand (R): as shown
lefthand version (L): mirror image

Abmessungen in mm

dimensions in mm



Bestellnummer part number	Ø D1 g7	*D min.	*t max.	L2	L3	Spannpratze claw	Spannschraube screw	Spannbereich S holding capacity S	
								<=	Wende- schneidplatte S indexable insert S
R/L .0.660.0025.1-D	25	46		170	20	PD.0.660.2	ZT300	0.5 - 2.0	
R/L .0.660.0032.1-D	32	46		200	20			1.9 - 3.0	
R/L .0.660.0040.1-D	40	46		250	-			2.9 - 4.0	
R/L .0.660.0025.2-D	25	46		170	20			3.9 - 6.5	
R/L .0.660.0032.2-D	32	46		200	20				
R/L .0.660.0040.2-D	40	46		250	-				
R/L .0.660.0025.3-D	25	46		170	20				
R/L .0.660.0032.3-D	32	46		200	20				
R/L .0.660.0040.3-D	40	46		250	-				
R/L .0.660.0025.4-D	25	46		170	20				
R/L .0.660.0032.4-D	32	46		200	20				
R/L .0.660.0040.4-D	40	46		250	-				

*D min.	46	50	60	80	100
*Stechtiefe t max. / max. depth of groove	2	3	4	4.5	5

Bestellbeispiel:
für rechte Ausführung
R.0.660.0025.1-D

order-example:
righthand version
R.0.660.0025.1-D

SYSTEM DED

Einstecken mit dreischneidigen Wendeplatten

grooving with three-cutting edges indexable inserts

Typ .0.736

Klemhalter, zum Abstechen, Außenbearbeitung

toolholder, for parting off, external application

Stechtiefe t max. 8 mm
Stechbreite S 0.5 - 1.2 mm

depth of groove t max. 8 mm
width of groove S 0.5 - 1.2 mm

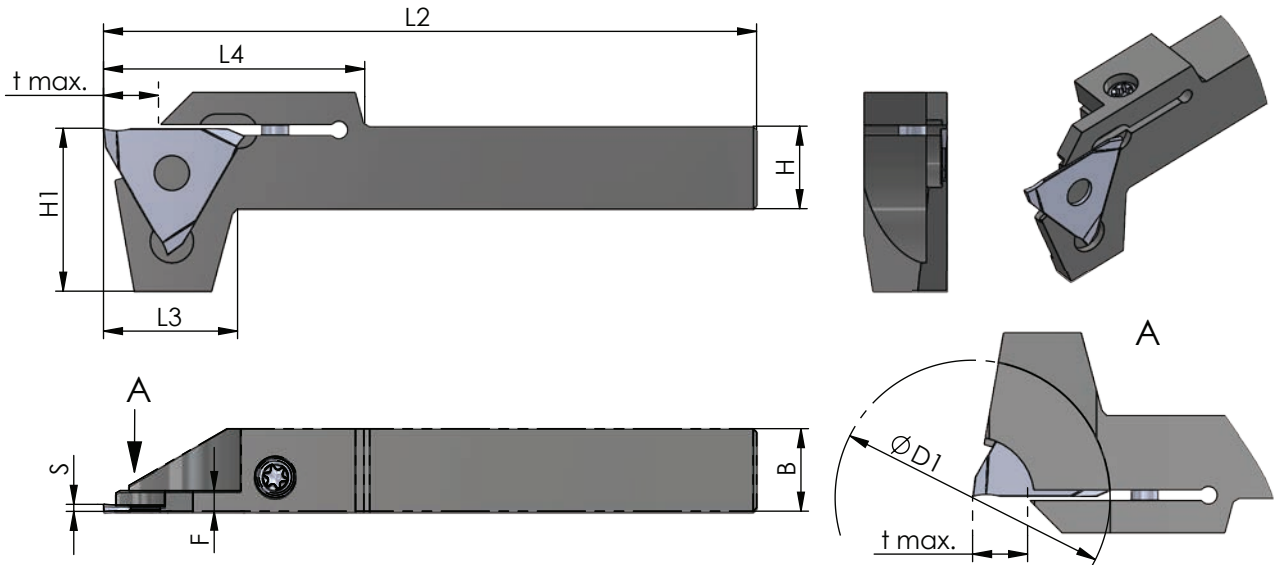

Rechts (R): wie gezeichnet
Links (L): spiegelbildlich

righthand (R): as shown
lefthand version (L): mirror image

Abmessungen in mm

dimensions in mm

Bestellnummer part number	H = B	H1	t max.	L2	L3	L4	F	Ø D1	Spannschraube screw	Schraubenschlüssel wrench	für Wende- schneidplatten for indexable inserts	Stechbreite S width of groove S
R/L .0.736.1212-D	12	24	8	95	19.5	38	3	40	M4-MC	TR15	R/L DED.0805.00	0.5
											R/L DED.0808.00	0.8
											R/L DED.0510.00	1.0
											R/L DED.0512.00	1.2
											R/L DED.1210.00	1.0
R/L .0.736.1616-D	16	24	8	95	19.5	38	3	40	M4-MC	TR15	R/L DED.0805.00	0.5
											R/L DED.0808.00	0.8
											R/L DED.0510.00	1.0
											R/L DED.0512.00	1.2
											R/L DED.1210.00	1.0

Bestellbeispiel:
für rechte Ausführung
R.0.736.1212-D

order-example:
righthand version
R.0.736.1212-D

SYSTEM DED

Einstecken mit dreischneidigen Wendepplatten

grooving with three-cutting edges indexable inserts

Typ Stechdrehen

Wendeschneidplatte, für Sicherungsringe DIN 471 / 472 und Stechdrehen allgemein

indexable insert, for circlips DIN 471 / 472 and general grooving

Stechbreite S 0.57 - 5.29 mm

width of groove S 0.57 - 5.29 mm

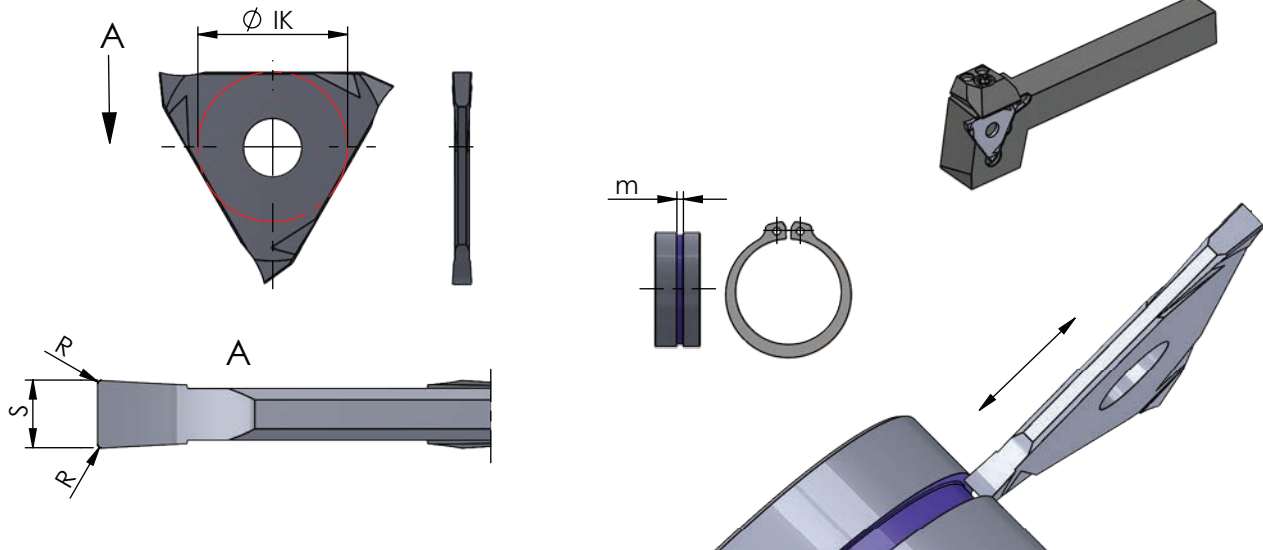

Wendeschneidplatten sind in rechten und linken Klemmhaltern sowie Bohrstängen verwendbar

inserts can be used in RH and LH toolholders as well as in boring bars

Abmessungen in mm

dimensions in mm



Bestellnummer part number	Nut-Maß m groove dim. m DIN 471 / DIN 472	S -0.05	S (inch)	R	Ø IK ± 0.06	Ø IK -0.03	K10F CN45F AL41F P07C	Klemmhalter Typ toolholder type	
DED.0050.00	0.5	0.57		0.05	13.0		● ● ●	R/L .207,1-D R/L .0.738,1-D R/L .0.660,1-D	
DED.0060.00	0.6	0.67		0.05	13.0		● ● ●		
DED.U066.00	-	0.66	0.026"	0.05	13.0		● ● ●		
DED.0070.00	0.7	0.77		0.05	13.0		● ● ●		
DED.0080.00	0.8	0.87		0.05	13.0		● ● ●		
DED.0090.00	0.9	0.97		0.05	13.0		● ● ●		
DED.0100.00	1.0	1.07		0.1	13.0		● ● ●		
DED.0110.00	1.1	1.24		0.1	13.0		● ● ●		
DED.U117.00	-	1.17	0.046"	0.1	13.2		● ● ●		
DED.0130.00	1.3	1.44		0.1	13.2		● ● ●		
DED.U142.00	-	1.42	0.056"	0.1	13.2		● ● ●		
DED.0160.00	1.6	1.74		0.1	13.2		● ● ●		
DED.0185.00	1.85	1.99		0.1	13.2		● ● ●		
DED.U198.00	-	1.98	0.078"	0.1	13.2		● ● ●		
↳ ...									

Weitere HM Sorten können Sie in der Sortenübersicht im Kapitel "Technische Hinweise" und der Preisliste finden.

Bestellbeispiel:
für Sorte AL41F:
DED.0050.00/AL41F

More carbide grades you can find in the grades summary in the chapter "technical instructions" and in the price list.

order-example:
grade AL41F:
DED.0050.00/AL41F

SYSTEM DED

Einstecken mit dreischneidigen Wendeplatten

grooving with three-cutting edges indexable inserts

Typ Stechdrehen

Wendeschneidplatte, für Sicherungsringe DIN 471 / 472 und Stechdrehen allgemein

indexable insert, for circlips DIN 471 / 472 and general grooving

Stechbreite S 0.57 - 5.29 mm

width of groove S 0.57 - 5.29 mm

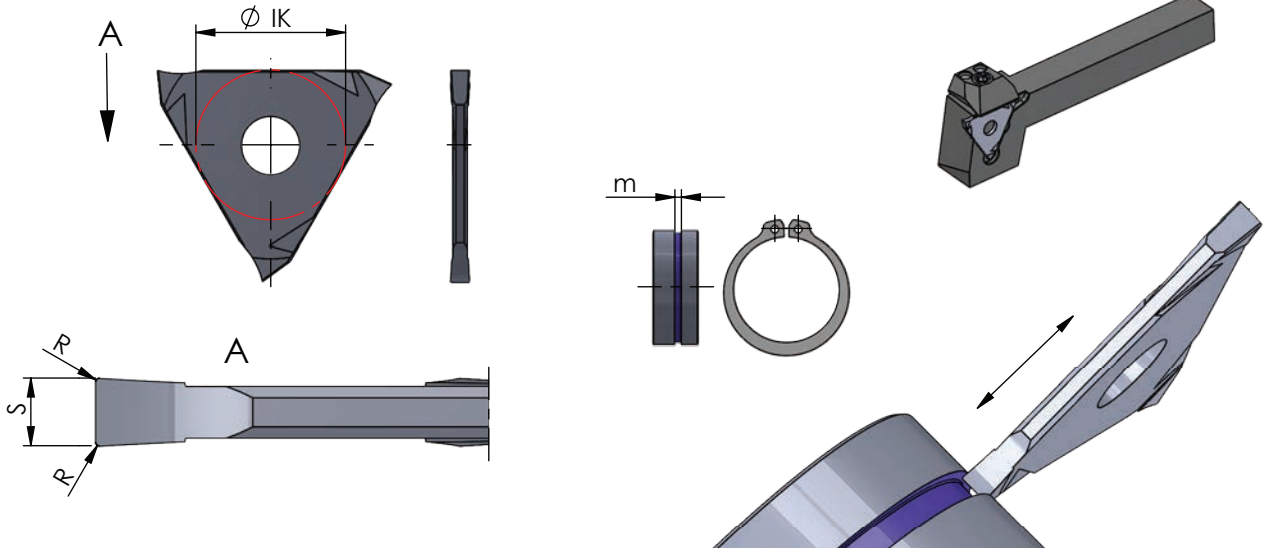

Wendeschneidplatten sind in rechten und linken Klemmhaltern sowie Bohrstängen verwendbar

inserts can be used in RH and LH toolholders as well as in boring bars

Abmessungen in mm

dimensions in mm

Bestellnummer part number	Nut-Maß m groove dim. m DIN 471 / DIN 472	S -0.05	S (inch)	R	Ø IK ± 0.06	Ø IK -0.03					Klemmhalter Typ toolholder type
							K10F	CN45F	AL41F	P07C	
DED.0215.00	2.15	2.29	0.1	13.2	●	●	●			R/L .207. 2-D R/L .0.738. 2-D R/L .0.780. 2-D R/L .0.660. 2-D	
DED.U223.00	-	2.23	0.088"	0.1	13.2			●			
DED.U238.00	-	2.38	0.094"	0.1	13.2			●			
DED.0265.00	2.65	2.79	0.1	13.2	●	●	●				
DED.0315.00	3.15	3.29	0.1	13.2	●	●	●			R/L .207. 3-D R/L .0.738. 3-D R/L .0.780. 3-D R/L .0.660. 3-D	
DED.U398.00	-	3.98	0.157"	0.1	13.2			●			
DED.0415.00	4.15	4.29	0.1	13.2	●	●	●			R/L .207. 4-D R/L .0.738. 4-D R/L .0.780. 4-D R/L .0.660. 4-D	
DED.0515.00	5.15	5.29	0.1	13.2	●	●	●				

Weitere HM Sorten können Sie in der Sortenübersicht im Kapitel "Technische Hinweise" und der Preisliste finden.

More carbide grades you can find in the grades summary in the chapter "technical instructions" and in the price list.

Bestellbeispiel:
für Sorte AL41F:
DED.0215.00/AL41F

order-example:
grade AL41F:
DED.0215.00/AL41F

SYSTEM DED

Einstecken mit dreischneidigen Wendeplatten

grooving with three-cutting edges indexable inserts

Typ Stechdrehen

Wendeschneidplatte, für unterbrochene Schnitte und Sicherungsringe DIN 471 / 472

indexable insert, for interrupted cuts and circlips DIN 471 / 472

Stechbreite S 1.07 - 5.29 mm

width of groove S 1.07 - 5.29 mm

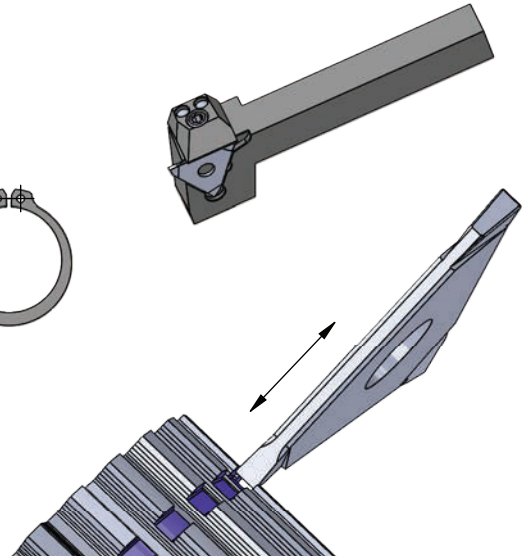
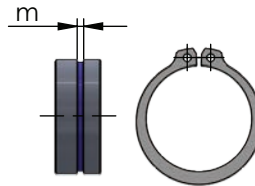
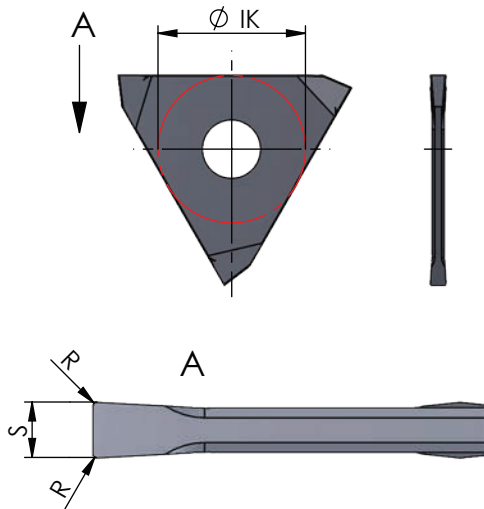

Wendeschneidplatten sind in rechten und linken Klemmhaltern sowie Bohrstäben verwendbar

inserts can be used in RH and LH toolholders as well as in boring bars

Abmessungen in mm

dimensions in mm



Bestellnummer part number	Nut-Maß m groove dim. m DIN 471 / DIN 472	S -0.05	R	Ø IK -0.03	Klemmhalter Typ toolholder type			
					K10F	CN45F	AL41F	P07C
DED.0100.NG-D	1.0	1.07	0.1	13.0	●	●	●	R/L .207, 1-D R/L .0.738, 1-D R/L .0.660, 1-D
DED.0110.NG-D	1.1	1.24	0.1	13.0	●	●	●	
DED.0130.NG-D	1.3	1.44	0.1	13.0	●	●	●	
DED.0160.NG-D	1.6	1.74	0.1	13.0	●	●	●	
DED.0185.NG-D	1.85	1.99	0.1	13.0	●	●	●	
DED.0215.NG-D	2.15	2.29	0.1	13.0	●	●	●	R/L .207, 2-D R/L .0.738, 2-D R/L .0.780, 2-D R/L .0.660, 2-D
DED.0265.NG-D	2.65	2.79	0.1	13.0	●	●	●	
DED.0315.NG-D	3.15	3.29	0.1	13.0	●	●	●	
DED.0415.NG-D	4.15	4.29	0.1	13.0	●	●	●	R/L .207, 4-D R/L .0.738, 4-D R/L .0.780, 4-D R/L .0.660, 4-D
DED.0515.NG-D	5.15	5.29	0.1	13.0	●	●	●	

Weitere HM Sorten können Sie in der Sortenübersicht im Kapitel "Technische Hinweise" und der Preisliste finden.

Bestellbeispiel:
für Sorte AL41F:
DED.0100.NG-D/AL41F

More carbide grades you can find in the grades summary in the chapter "technical instructions" and in the price list.

order-example:
grade AL41F:
DED.0100.NG-D/AL41F

SYSTEM DED

Einstecken mit dreischneidigen Wendepplatten

grooving with three-cutting edges indexable inserts

Typ Stechdrehen

Wendeschneidplatte, für Sicherungsringe DIN 471 / 472, stabile Ausführung

indexable insert, for circlips DIN 471 / 472, solid construction

Stechbreite C 0.55 - 1.05 mm

width of groove C 0.55 - 1.05 mm

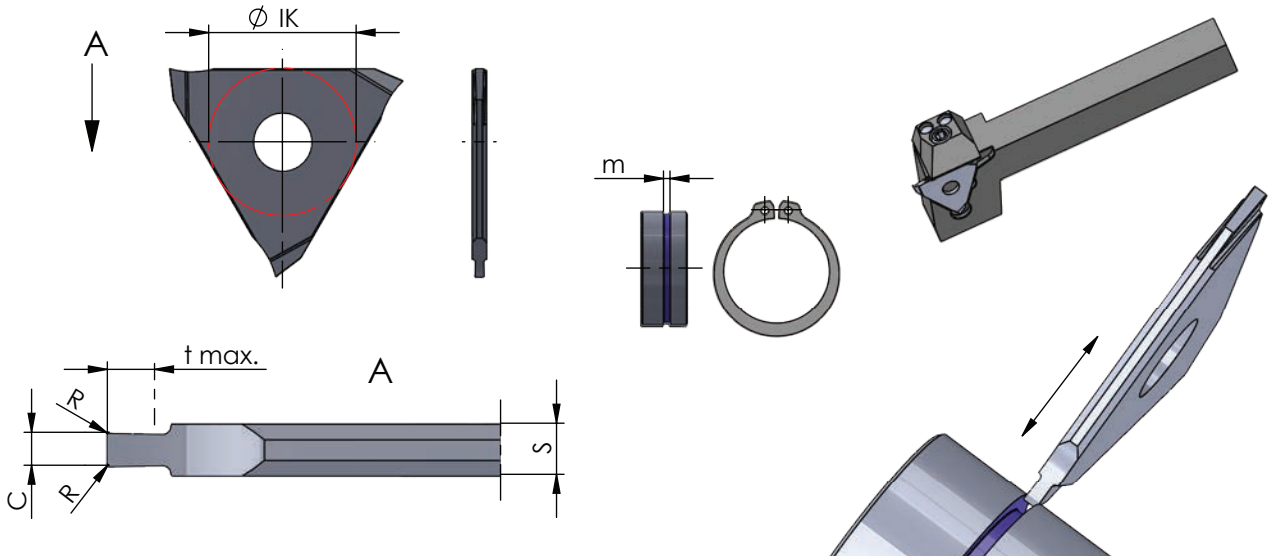

Wendeschneidplatten sind in rechten und linken Klemmhaltern sowie Bohrstängen verwendbar

inserts can be used in RH and LH toolholders as well as in boring bars

Abmessungen in mm

dimensions in mm

Bestellnummer part number	Nut-Maß m groove dim. m DIN 471 / DIN 472	C -0.03	S ±0.02	t max.	R	Ø IK -0.03					Klemmhalter Typ toolholder type
							K10F	CN45F	AL41F	P07C	
DED.0050.13	0.5	0.55	1.3	0.7	0.05	13.0	●	●			R/L .207, 1-D R/L .0.738, 1-D R/L .0.660, 1-D
DED.0060.13	0.6	0.65	1.3	0.8	0.05	13.0	●	●			
DED.0070.13	0.7	0.75	1.3	1.1	0.05	13.0	●	●			
DED.0080.13	0.8	0.85	1.3	1.2	0.05	13.0	●	●			
DED.0090.13	0.9	0.95	1.3	1.4	0.05	13.0	●	●			
DED.0100.13	1.0	1.05	1.3	1.6	0.1	13.0	●	●			

Weitere HM Sorten können Sie in der Sortenübersicht im Kapitel "Technische Hinweise" und der Preisliste finden.

More carbide grades you can find in the grades summary in the chapter "technical instructions" and in the price list.

Bestellbeispiel:
für Sorte AL41F:
DED.0050.13/AL41F

order-example:
grade AL41F:
DED.0050.13/AL41F

SYSTEM DED

Einstecken mit dreischneidigen Wendeplatten

grooving with three-cutting edges indexable inserts

Typ Stechdrehen

Wendeschneidplatte, für Sicherungsringe DIN 471 / 472 mit Nutaußenkantenfasung

indexable insert, for circlips DIN 471 / 472 with chamfer

Stechbreite C 1.24 - 5.29 mm

width of groove C 1.24 - 5.29 mm

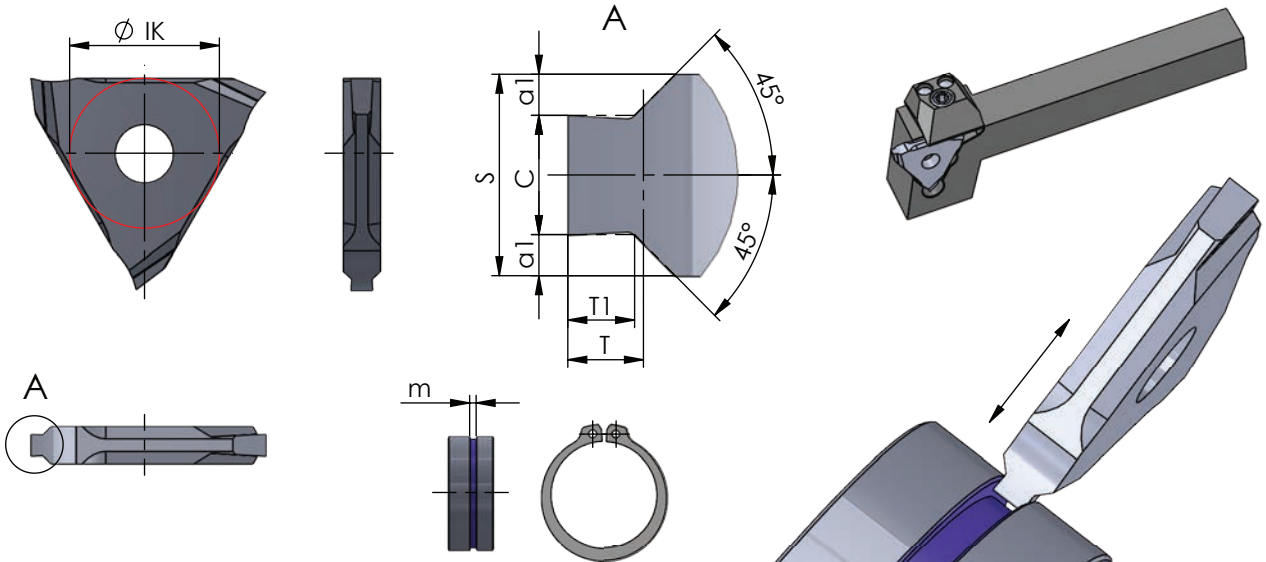

Wendeschneidplatten sind in rechten und linken Klemmhaltern sowie Bohrstängen verwendbar

inserts can be used in RH and LH toolholders as well as in boring bars

Abmessungen in mm

dimensions in mm



Bestellnummer part number	Nut-Maß m groove dim. m DIN 471 / DIN 472	C -0.05	S	a	T1 -0.05	T	Ø IK ± 0.06					Klemmhalter Typ toolholder type
								K10F	CN45F	AL41F	P07C	
DED.1101.25	1.1	⊙	1.24	2.5	0.64	0.19	0.20	●	●	●		R/L .207,2-D R/L .0.738,2-D R/L .0.780,2-D R/L .0.660,2-D
DED.1102.25	1.1	⊙	1.24	2.5	0.64	0.24	0.25	●	●	●		
DED.1103.25	1.1	⊙	1.24	2.5	0.64	0.29	0.30	●	●	●		
DED.1104.25	1.1	⊙	1.24	2.5	0.64	0.33	0.35	●	●	●		
DED.1105.25	1.1	⊙	1.24	2.5	0.64	0.36	0.40	●	●	●		
DED.1306.25	1.3	⊙	1.44	2.5	0.54	0.45	0.55	●	●	●		
DED.1607.33	1.6	⊙	1.74	3.3	0.79	0.60	0.70	●	●	●		R/L .207,3-D R/L .0.738,3-D R/L .0.780,3-D R/L .0.660,3-D
DED.1608.33	1.6	⊙	1.74	3.3	0.79	0.75	0.85	●	●	●		
DED.1609.33	1.6	⊙	1.74	3.3	0.79	0.85	1.00	●	●	●		
DED.1810.33	1.85	⊙	1.99	3.3	0.67	0.85	1.00	●	●	●		
DED.1812.33	1.85	⊙	1.99	3.3	0.67	1.10	1.25	●	●	●		
↳ ...												

Weitere HM Sorten können Sie in der Sortenübersicht im Kapitel "Technische Hinweise" und der Preisliste finden.

Bestellbeispiel:
für Sorte AL41F:
DED.1101.25/AL41F

More carbide grades you can find in the grades summary in the chapter "technical instructions" and in the price list.

order-example:
grade AL41F:
DED.1101.25/AL41F

SYSTEM DED

Einstecken mit dreischneidigen Wendeplatten

grooving with three-cutting edges indexable inserts

Typ Stechdrehen

Wendeschneidplatte, für Sicherungsringe DIN 471 / 472 mit Nutaußenkantenfasung

indexable insert, for circlips DIN 471 / 472 with chamfer

Stechbreite C 1.24 - 5.29 mm

width of groove C 1.24 - 5.29 mm

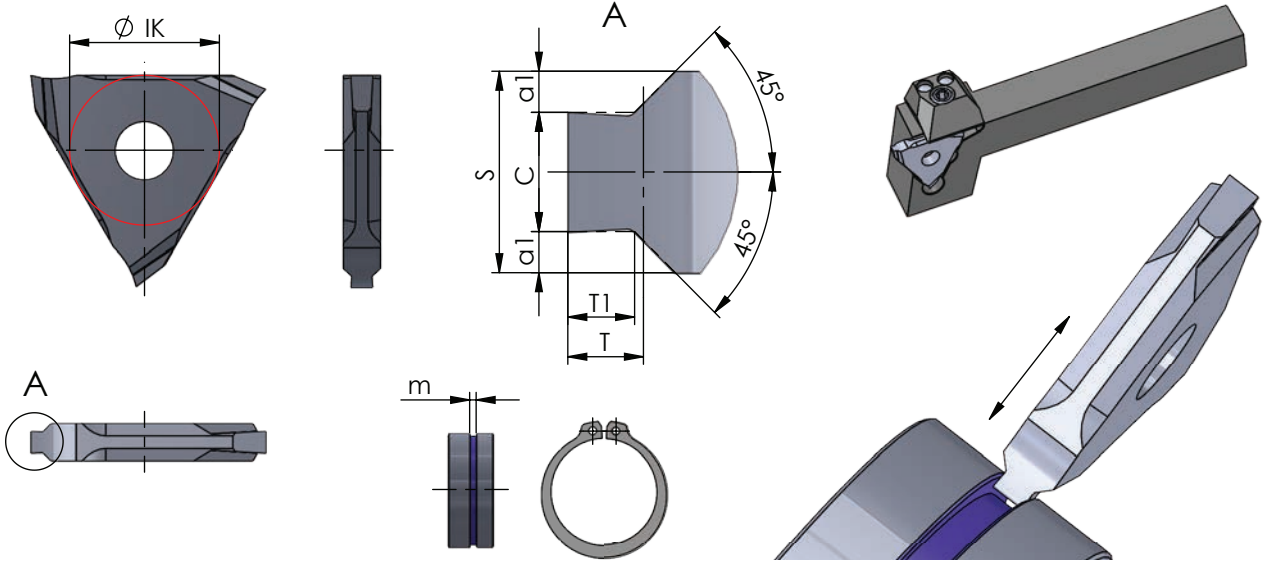

Wendeschneidplatten sind in rechten und linken Klemmhaltern sowie Bohrstängen verwendbar

inserts can be used in RH and LH toolholders as well as in boring bars

Abmessungen in mm

dimensions in mm

Bestellnummer part number	Nut-Maß m groove dim. m DIN 471 / DIN 472	C -0.05	S	a	T1 -0.05	T	Ø IK ± 0.06					Klemmhalter Typ toolholder type
								K10F	CN45F	AL41F	P07C	
DED.2115.43	2.15	2.29	4.3	1.02	1.35	1.50	13.2	●	●	●		R/L .207. 4-D R/L .0.738. 4-D R/L .0.780. 4-D R/L .0.660. 4-D
DED.2616.43	2.65	2.79	4.3	0.77	1.35	1.50	13.2	●	●	●		
DED.2617.43	2.65	2.79	4.3	0.77	1.60	1.75	13.2	●	●	●		
DED.3118.53	3.15	3.29	5.3	1.02	1.60	1.75	13.2	●	●	●		
DED.4120.53	4.15	4.29	5.3	0.52	1.85	2.00	13.2	●	●	●		
DED.4125.53	4.15	4.29	5.3	0.52	2.35	2.50	13.2	●	●	●		
DED.5130.63	5.15	5.29	6.3	0.52	2.85	3.00	13.2	●	●	●		

Weitere HM Sorten können Sie in der Sortenübersicht im Kapitel "Technische Hinweise" und der Preisliste finden.

More carbide grades you can find in the grades summary in the chapter "technical instructions" and in the price list.

Bestellbeispiel:
für Sorte AL41F:
DED.2115.43/AL41F

order-example:
grade AL41F:
DED.2115.43/AL41F

SYSTEM DED

Einstecken mit dreischneidigen Wendepplatten

grooving with three-cutting edges indexable inserts

Typ Stechdrehen

Wendeschneidplatte, zum Feindreihen

indexable insert, for finishing

Stechbreite S 1.0 - 4.0 mm

width of groove S 1.0 - 4.0 mm

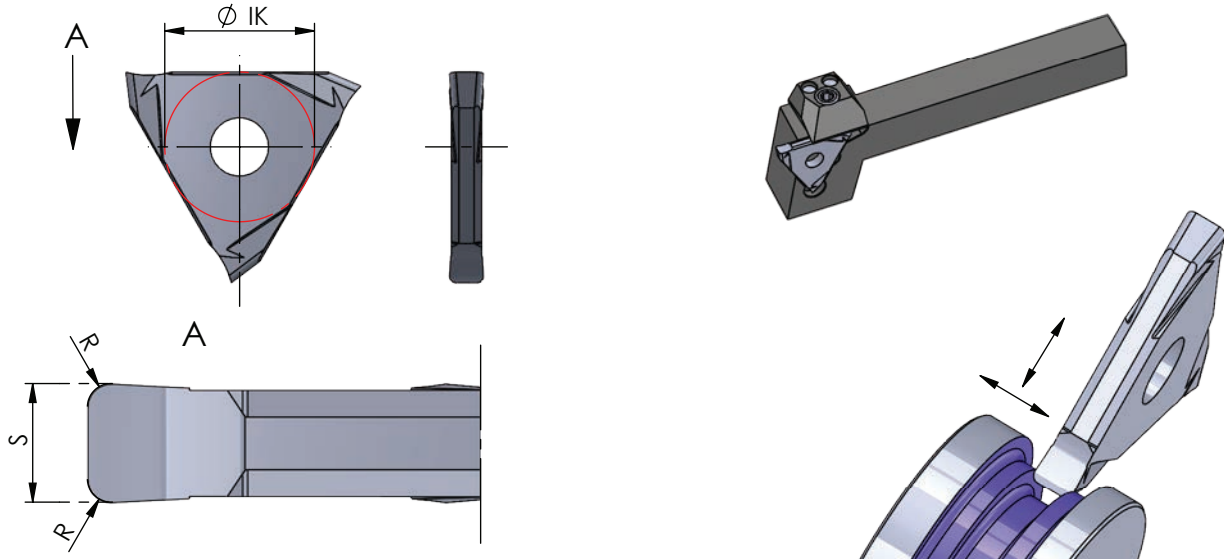

Wendeschneidplatten sind in rechten und linken Klemmhaltern sowie Bohrstängen verwendbar

inserts can be used in RH and LH toolholders as well as in boring bars

Abmessungen in mm

dimensions in mm



Bestellnummer part number								Klemmhalter Typ toolholder type
	S +0.03	R	Ø IK ± 0.06	K10F	CN45F	AL41F	P07C	
DED.0100.02	1.0	0.2	13.2	●		●		R/L .207.1-D R/L .0.738.1-D (R/L .0.660.1-D)
DED.0150.02	1.5	0.2	13.2	●	●	●		
DED.0200.02	2.0	0.2	13.2	●	●	●		
DED.0200.04	2.0	0.4	13.2	●	●	●		
DED.0300.02	3.0	0.2	13.2	●	●	●		R/L .207.2-D R/L .0.738.2-D (R/L .0.780.2-D) (R/L .0.660.2-D)
DED.0300.06	3.0	0.6	13.2	●	●	●		
DED.0300.08	3.0	0.8	13.2	●	●	●		
DED.0400.02	4.0	0.2	13.2	●	●	●		
DED.0400.08	4.0	0.8	13.2	●	●	●		R/L .207.3-D R/L .0.738.3-D (R/L .0.780.3-D) (R/L .0.660.3-D)
DED.0400.12	4.0	1.2	13.2	●	●	●		

Weitere HM Sorten können Sie in der Sortenübersicht im Kapitel "Technische Hinweise" und der Preisliste finden.

Bestellbeispiel:
für Sorte AL41F:
DED.0100.02/AL41F

More carbide grades you can find in the grades summary in the chapter "technical instructions" and in the price list.

order-example:
grade AL41F:
DED.0100.02/AL41F

SYSTEM DED

Einstecken mit dreischneidigen Wendeplatten

grooving with three-cutting edges indexable inserts

Typ Stechdrehen

Wendeschneidplatte, Vollradius, für Nuten und Eckenfreistich

indexable insert, full radius, for grooving and corner reliefs

Stechbreite S 0.5 - 5.0 mm

width of groove S 0.5 - 5.0 mm

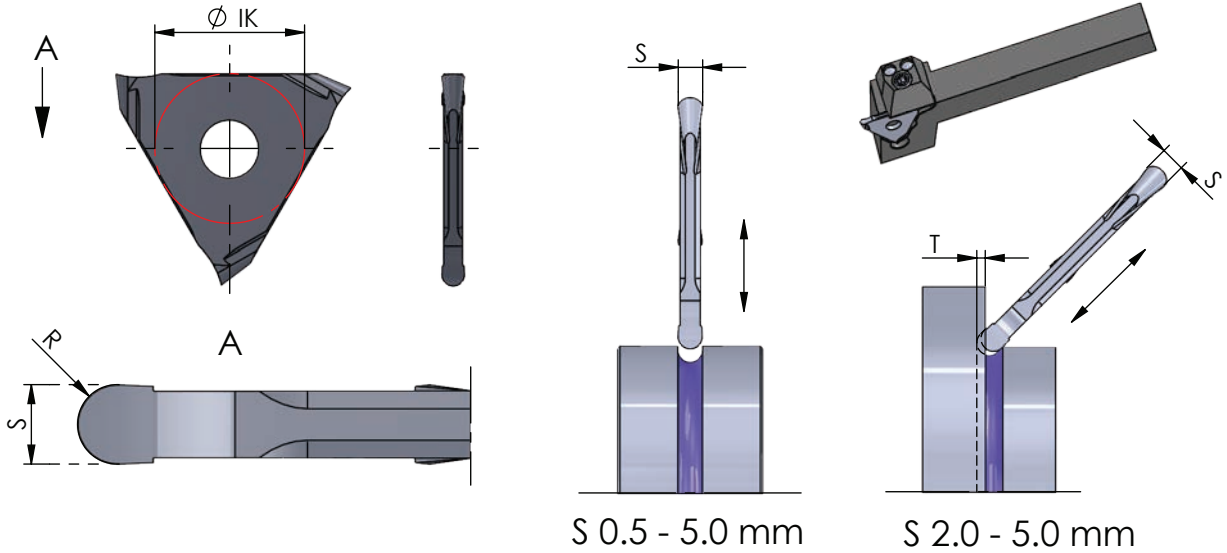

S 0.5 - 5.0 mm

S 2.0 - 5.0 mm

Wendeschneidplatten sind in rechten und linken Klemmhaltern sowie Bohrstäben verwendbar

inserts can be used in RH and LH toolholders as well as in boring bars

Abmessungen in mm

dimensions in mm

Bestellnummer part number	Abmessungen in mm					Material				Klemmhalter Typ toolholder type
	S ±0.05	S ±0.02	R	T	Ø IK ± 0.06	K10F	CN45F	AL41F	P07C	
DED.0002.05		0.5	0.25		13.2	●	●	●		R/L .207. 1-D R/L .0.738. 1-D R/L .0.660. 1-D
DED.0005.10		1.0	0.50		13.2	●	●	●		
DED.0006.12		1.2	0.60		13.2	●	●	●		
DED.0008.16		1.6	0.80		13.2	●	●	●		
DED.0010.20	2.0		1.00	0.70	13.2	●	●	●		R/L .207. 2-D R/L .0.738. 2-D R/L .0.780. 2-D R/L .0.660. 2-D R/L .0.618. 2-D
DED.0012.25	2.5		1.25	0.85	13.2	●	●	●		
DED.0015.30	3.0		1.50	1.00	13.2	●	●	●		
DED.0020.40	4.0		2.00	1.20	13.2	●	●	●		
DED.0025.50	5.0		2.50	1.50	13.2	●	●	●		R/L .207. 4-D R/L .0.738. 4-D R/L .0.780. 4-D R/L .0.660. 4-D R/L .0.618. 4-D

Weitere HM Sorten können Sie in der Sortenübersicht im Kapitel "Technische Hinweise" und der Preisliste finden.

More carbide grades you can find in the grades summary in the chapter "technical instructions" and in the price list.

Bestellbeispiel:
für Sorte AL41F:
DED.0002.05/AL41F

order-example:
grade AL41F:
DED.0002.05/AL41F

SYSTEM DED

Einstecken mit dreischneidigen Wendeplatten

grooving with three-cutting edges indexable inserts

Typ Stechdrehen

Wendeschneidplatte, mit Spanformer, zum Abstechen

indexable insert, with chipformer, for parting off

Stechbreite S 1.99 - 2.79 mm

width of groove S 1.99 - 2.79 mm

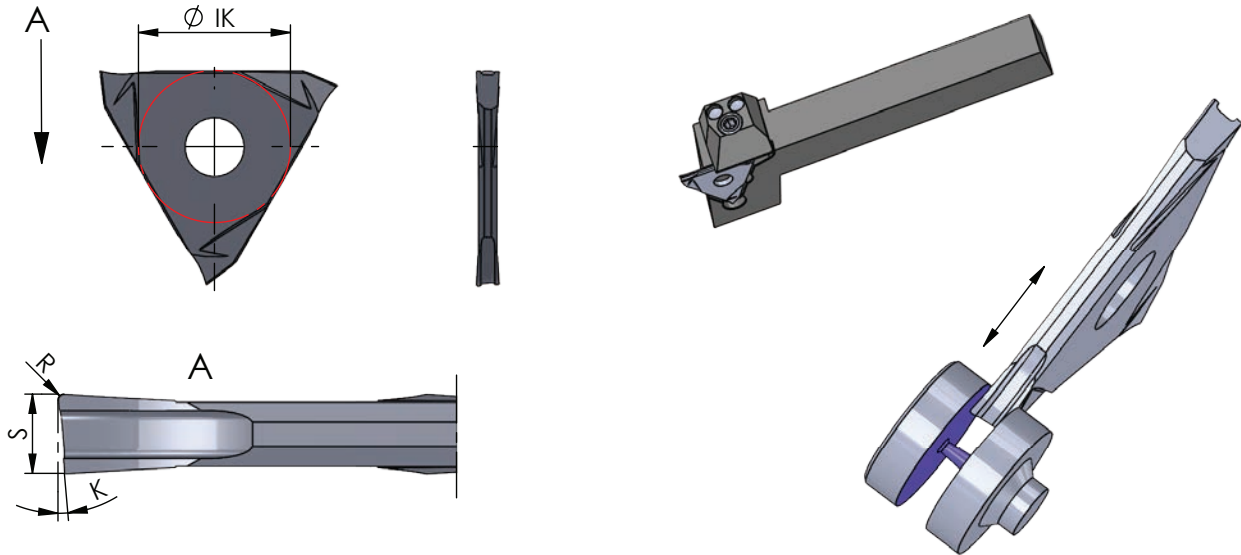

Rechts (R): wie gezeichnet
Links (L): spiegelbildlich

Wendeschneidplatten sind in rechten und linken Klemmhaltern verwendbar.
Abmessungen in mm

righthand version (R): as shown
lefthand version (L): mirror image

inserts can be used in RH and LH toolholders

dimensions in mm



Bestellnummer part number	S -0.05	K	R	Ø IK ± 0.06	Klemmhalter Typ toolholder type			
					K10F	CN45F	AL41F	P07C
R/L .DED.0518.00	1.99	5°	0.15	13.2	●	●	●	R/L .207.1-D R/L .0.738.1-D
R/L .DED.0521.00	2.29	5°	0.15	13.2	●	●	●	R/L .207.2-D
R/L .DED.0526.00	2.79	5°	0.15	13.2	●	●	●	R/L .0.738.2-D R/L .0.780.2-D

Weitere HM Sorten können Sie in der Sortenübersicht im Kapitel "Technische Hinweise" und der Preisliste finden.

Bestellbeispiel:
für rechte Ausführung und Sorte:
R.DED.0518.00/AL41F

More carbide grades you can find in the grades summary in the chapter "technical instructions" and in the price list.

order-example:
righthand version and grade:
R.DED.0518.00/AL41F

SYSTEM DED

Einstecken mit dreischneidigen Wendepplatten

grooving with three-cutting edges indexable inserts

Typ Stechdrehen

Wendeschneidplatte, ohne Spanformer, zum Abstechen

indexable insert, without chipformer, for parting off

Stechbreite S 0.5 - 1.4 mm

width of groove S 0.5 - 1.4 mm

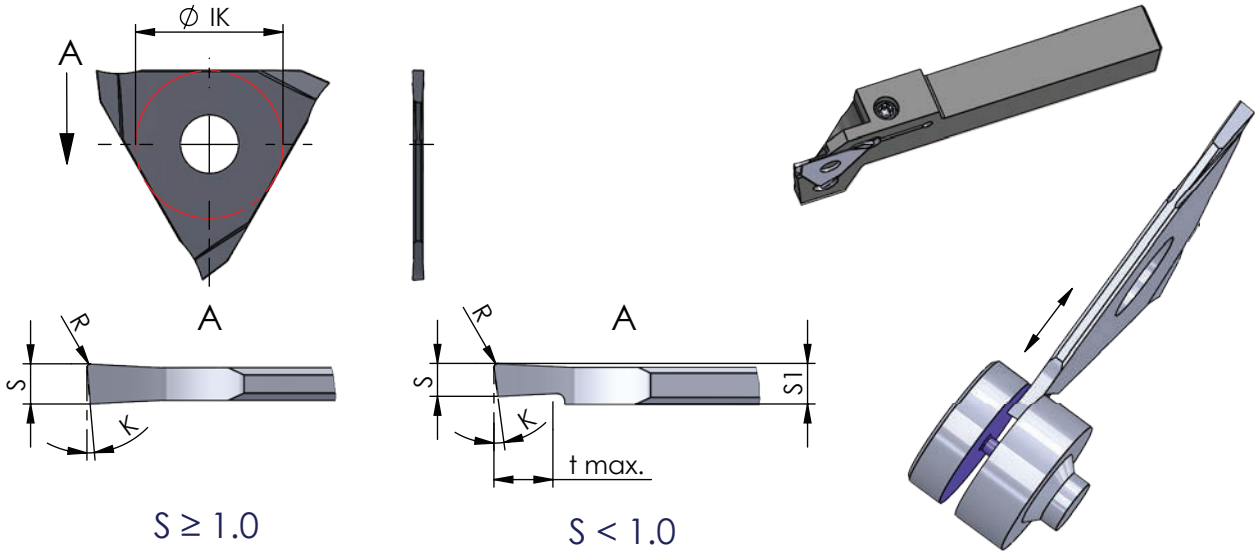

Rechts (R): wie gezeichnet
Links (L): spiegelbildlich

Wendeschneidplatten sind in rechten und linken Klemmhaltern verwendbar.
Abmessungen in mm

righthand version (R): as shown
lefthand version (L): mirror image

inserts can be used in RH and LH toolholders

dimensions in mm

Bestellnummer part number	S1 -0.05	S +0.05	K	R	t max.	Ø IK ± 0.06	Ø IK - 0.03	Klemmhalter Typ toolholder type			
								K10F	CN45F	AL41F	P07C
R/L .DED.0805.00	1.0	0.5	8°	0.1	1.0			●	●	R/L .207.1-D R/L .0.736.	
R/L .DED.0808.00	1.0	0.8	8°	0.1	1.5			●	●		
R/L .DED.0510.00		1.0	5°	0.1				●	●		
R/L .DED.0512.00		1.2	5°	0.1				●	●		
R/L .DED.1210.00		1.0	12°	0.1				●	●		
R/L .DED.0614.00		1.4	6°	0.1		13.2		●	●	R/L .207.1-D	

Weitere HM Sorten können Sie in der Sortenübersicht im Kapitel "Technische Hinweise" und der Preisliste finden.

Bestellbeispiel:
für rechte Ausführung und Sorte:
R.DED.0805.00/AL41F

More carbide grades you can find in the grades summary in the chapter "technical instructions" and in the price list.

order-example:
righthand version and grade:
R.DED.0805.00/AL41F

SYSTEM DED

Einstecken mit dreischneidigen Wendeplatten

grooving with three-cutting edges indexable inserts

Typ Stechdrehen

Wendeschneidplatte, zum Einstechen und Längsdrehen

indexable insert, for grooving and turning

Stechtiefe t max. 3.5
Stechbreite C 3.29 mm

depth of groove t max. 3.5
width of groove C 3.29 mm

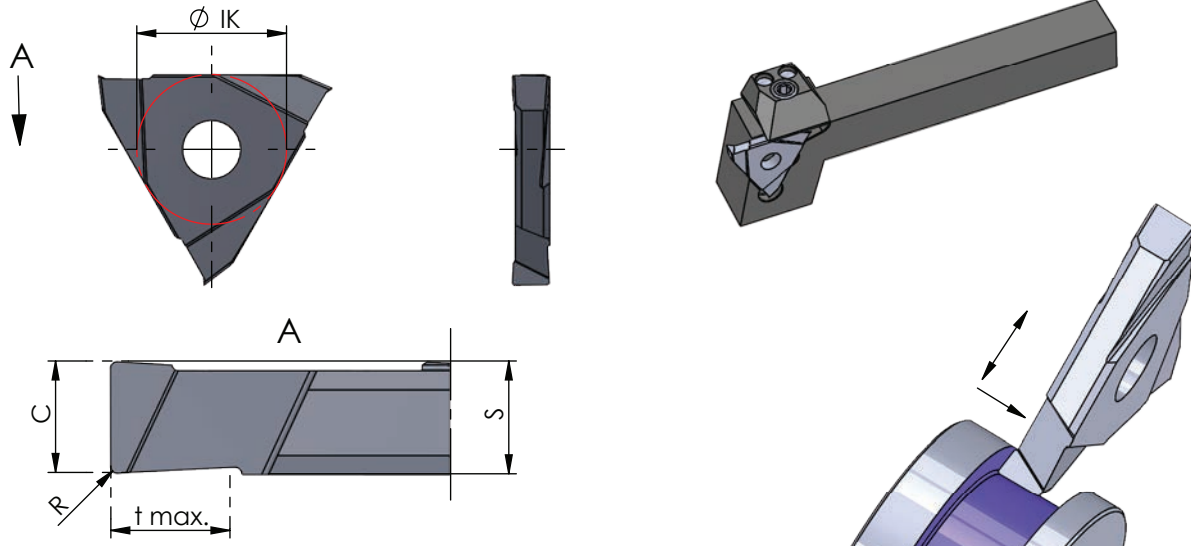

Rechts (R): wie gezeichnet
Links (L): spiegelbildlich

Rechte Schneidpl. in rechtem Halter
Linke Schneidpl. in linkem Halter

Abmessungen in mm

righthand version (R): as shown
lefthand version (L): mirror image

use RH insert in RH tool holder and
LH insert in LH tool holder

dimensions in mm



Bestellnummer part number	C -0.05	S +0.05	R	t max.	Ø IK ± 0.06	Klemmhalter Typ toolholder type				
						K10F	CN45F	AL41F	P07C	
R/L .DED.3031.33	3.29	3.3	0.2	3.5	13.2	●	●	●		R/L .207.2-D R/L .0.738.2-D

Weitere HM Sorten können Sie in der Sortenübersicht im Kapitel "Technische Hinweise" und der Preisliste finden.

Bestellbeispiel:
für rechte Ausführung und Sorte:
R.DED.3031.33/AL41F

More carbide grades you can find in the grades summary in the chapter "technical instructions" and in the price list.

order-example:
righthand version and grade:
R.DED.3031.33/AL41F

SYSTEM DED

Einstecken mit dreischneidigen Wendeplatten

grooving with three-cutting edges indexable inserts

Typ Stechdrehen

Wendeschneidplatte, für Eckenfreistich, ähnlich DIN 509 Form F

indexable insert, for corner reliefs, similar to DIN 509 type F

Stechbreite S 2.4 - 5.0 mm

width of groove S 2.4 - 5.0 mm

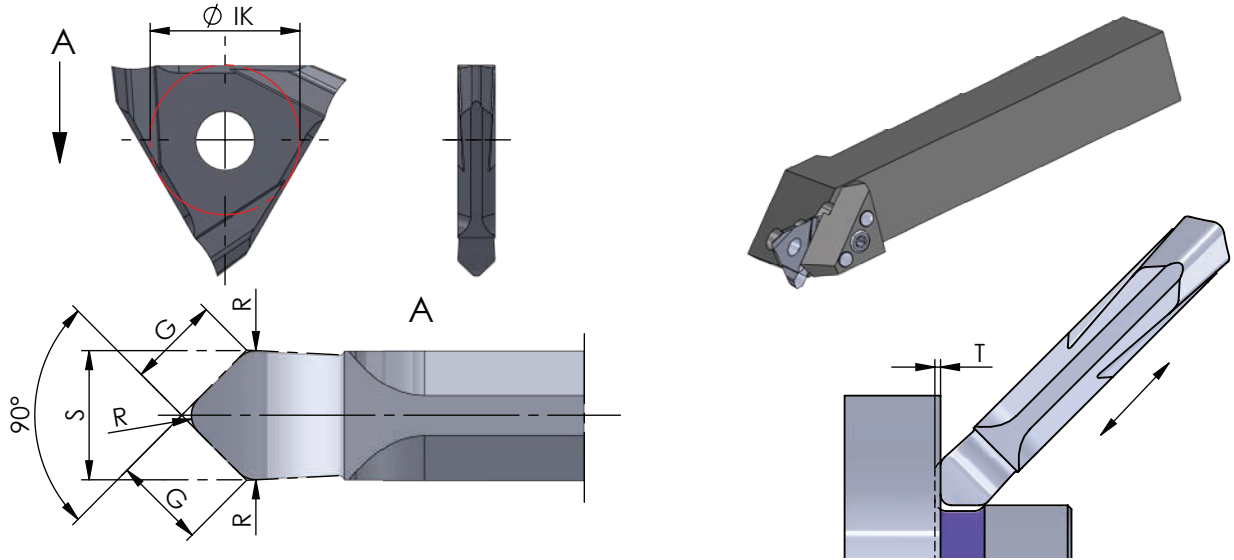

Wendeschneidplatten sind in rechten und linken Klemmhaltern verwendbar

inserts can be used in RH and LH toolholders

Abmessungen in mm

dimensions in mm

Bestellnummer part number					Ø IK ± 0.06					Klemmhalter Typ toolholder type
	S -0.05	G	R	T		K10F	CN45F	AL41F	P07C	
DED.0602.24	2.4	1.7	0.6	0.2	13.2	●	●	●		R/L .0.618.2-D
DED.0603.33	3.3	2.3	0.6	0.3	13.2	●	●	●		R/L .0.618.3-D
DED.1002.30	3.0	2.1	1.0	0.2	13.2	●	●	●		
DED.1004.50	5.0	3.6	1.0	0.4	13.2	●	●	●		R/L .0.618.4-D
DED.1603.50	5.0	3.6	1.6	0.3	13.2	●	●	●		

Weitere HM Sorten können Sie in der Sortenübersicht im Kapitel "Technische Hinweise" und der Preisliste finden.

More carbide grades you can find in the grades summary in the chapter "technical instructions" and in the price list.

Bestellbeispiel:
für Sorte AL41F:
DED.0602.24/AL41F

order-example:
grade AL41F:
DED.0602.24/AL41F

SYSTEM DED

Einstecken mit dreischneidigen Wendeplatten

grooving with three-cutting edges indexable inserts

Typ Stechdrehen

Wendeschneidplatte, Axialbearbeitung

indexable insert, face grooving

D min. 20 mm
Stechtiefe t max. 3.5
Stechbreite C 1.5 - 5.0 mm

D min. 20 mm
depth of groove t max. 3.5
width of groove C 1.5 - 5.0 mm

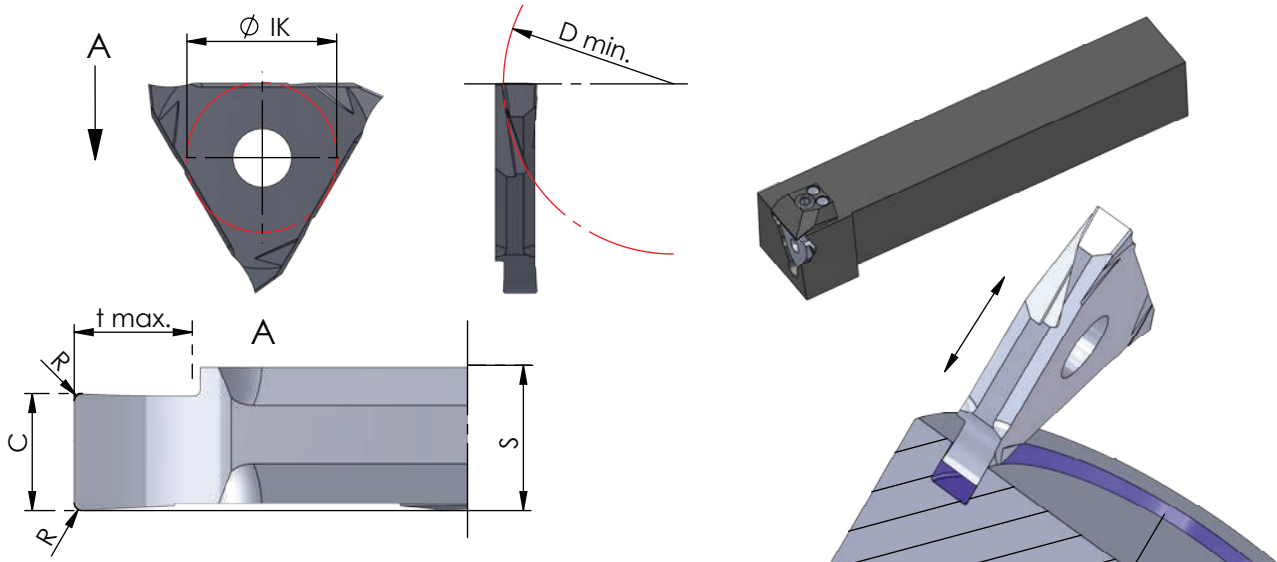

Links (L): wie gezeichnet
Rechts (R): spiegelbildlich

Wendeschneidplatten sind in rechten und linken Klemmhaltern verwendbar
Abmessungen in mm

lefthand version (L): as shown
righthand version (R): mirror image

inserts can be used in RH and LH toolholders

dimensions in mm



Bestellnummer part number	C ±0.02	S	R	t max.	D min.	Ø IK ± 0.06					Klemmhalter Typ toolholder type
							K10F	CN45F	AL41F	P07C	
R/L .DED.2015.2	1.5	2.7	0.2	2.0	20	13.2	●	●	●		(R/L .207.2-D)
R/L .DED.3020.2	2.0	2.7	0.2	3.0	30	13.2	●	●	●		R/L .0.738.2-D
R/L .DED.3030.2	3.0	3.7	0.2	3.0	30	13.2	●	●	●		(R/L .207.3-D) R/L .0.738.3-D
R/L .DED.3040.2	4.0	4.3	0.2	3.5	30	13.2	●	●	●		(R/L .207.4-D)
R/L .DED.3050.2	5.0	5.3	0.2	3.5	30	13.2	●	●	●		R/L .0.738.4-D

Weitere HM Sorten können Sie in der Sortenübersicht im Kapitel "Technische Hinweise" und der Preisliste finden.

Bestellbeispiel:
für rechte Ausführung und Sorte:
R.DED.2015.2/AL41F

More carbide grades you can find in the grades summary in the chapter "technical instructions" and in the price list.

order-example:
righthand version and grade:
R.DED.2015.2/AL41F

SYSTEM DED

Einstecken mit dreischneidigen Wendeplatten

grooving with three-cutting edges indexable inserts

Sets

Bestellnummer
part number

Inhalt
Content

K10F
CN45F
AL41F
P07C

SET-DED 1



- Halter (rechte Ausführung)
- für Sicherungsringe DIN 471 / 472
- und Stechdrehen allgemein
Stechbreite S 0.57 - 1.99

- toolholder (right version)
- for circlips
DIN 471 / 472
- and general grooving
width of groove S 0.57 - 1.99

Halter / toolholder:

1 x R.207.2020.1

Schneideinsatz / insert:

1 x DED.0050.00
1 x DED.0060.00
1 x DED.0070.00
1 x DED.0080.00
1 x DED.0090.00
1 x DED.0100.00
1 x DED.0110.00
1 x DED.0130.00
1 x DED.0160.00
1 x DED.0185.00

●
●
●
●
●
●
●
●
●
●

Weitere Ausführungen auf Anfrage oder in der Preisliste.

More versions on request and in the price list.

Bestellbeispiel:
SET-DED 1

order-example:
SET-DED 1

SYSTEM DED

Einstecken mit dreischneidigen Wendeplatten

grooving with three-cutting edges indexable inserts

Impressionen

impressions

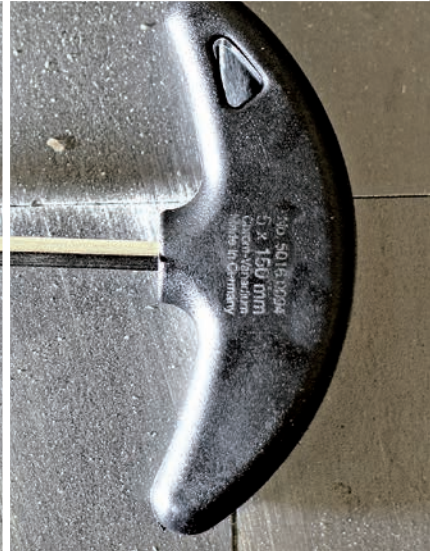
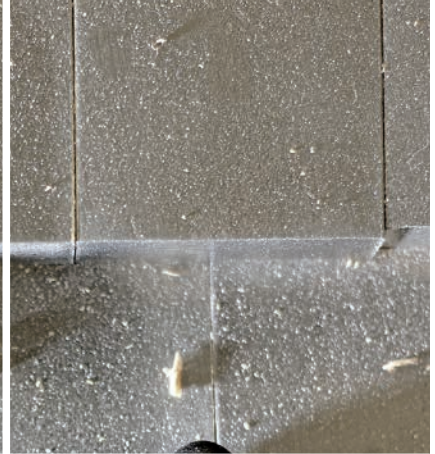

SYSTEM ZTP

Einstecken mit
zweischneidigen Wendeplatten

grooving with two-cutting
edges indexable inserts

Allgemeine Beschreibung

general instruction

System ZTP:

Robustes System zum Einstecken mit zweischneidigen Wendeplatten ab 2mm.

System ZTP:

Tough system for grooving with two-cutting edges indexable inserts starting at 2 mm.

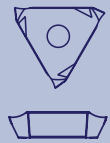
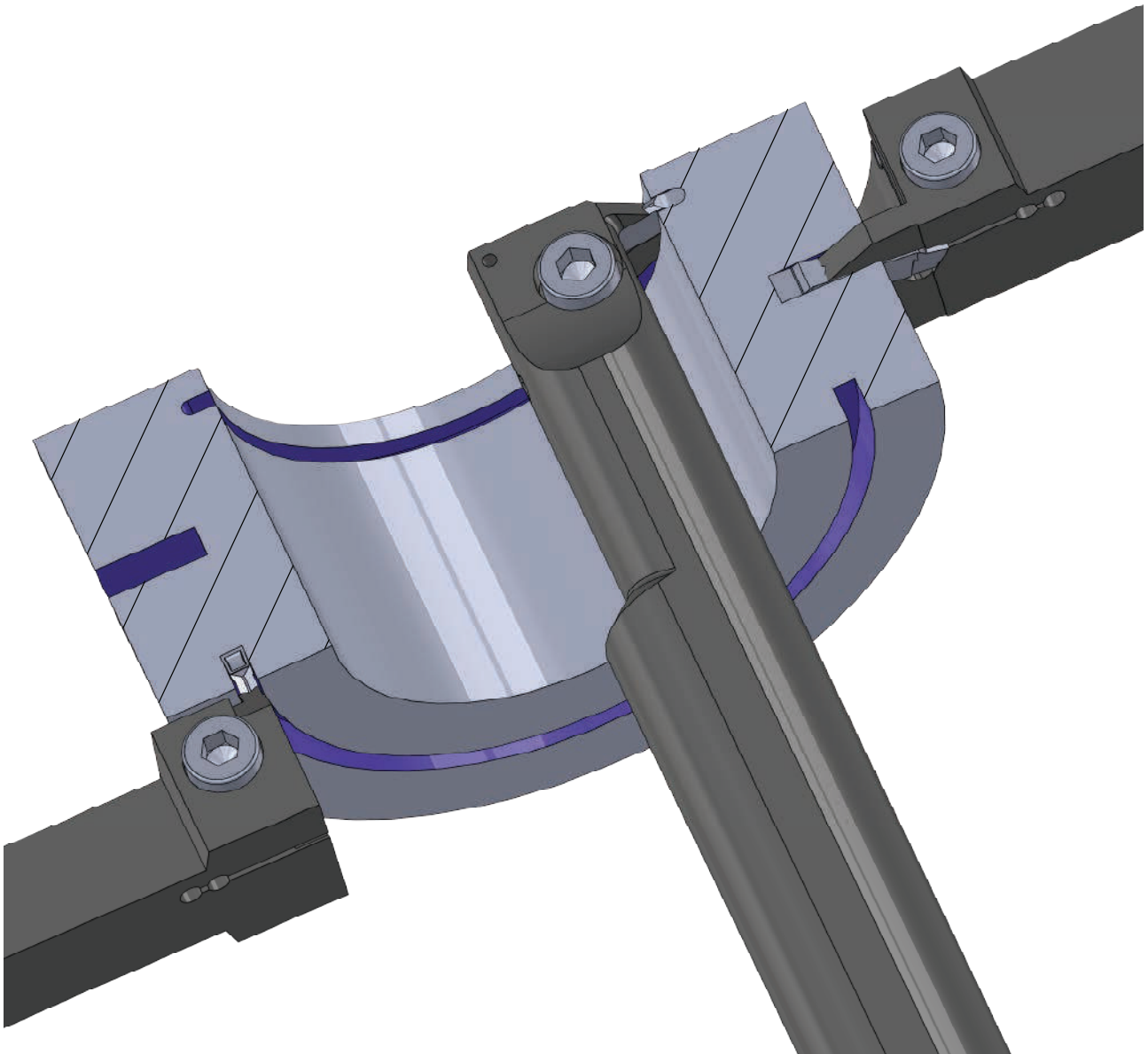

SYSTEM ZTP

Einstecken mit
zweischneidigen Wendeplatten

grooving with two-cutting
edges indexable inserts

Typ .212

Klemmhalter,
Außenbearbeitung

toolholder,
external application

Stechtiefe t max. 12 mm
Spannbereich S 2.0 - 6.0 mm

depth of groove t max. 12 mm
holding capacity S 2.0 - 6.0 mm

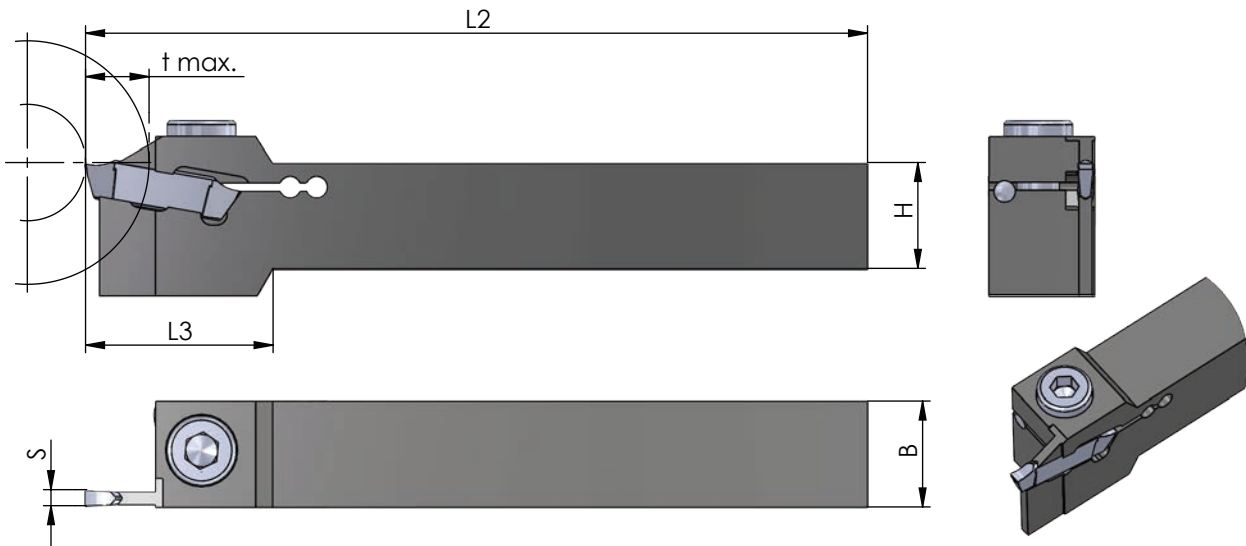

Rechts (R): wie gezeichnet
Links (L): spiegelbildlich

righthand (R): as shown
lefthand version (L): mirror image

Abmessungen in mm

dimensions in mm



Bestellnummer part number	H	B	t max.	L2	L3	Spannschraube screw	Schraubenschlüssel wrench	Spannbereich S holding capacity S	
								≤	Wende- schneidplatte S indexable insert S
R/L .212.1616.2-D	16	16	12	125	35				
R/L .212.2020.2-D	20	20	12	150	35	912	911	2.0 - 3.0	
R/L .212.2525.2-D	25	25	12	150	-				
R/L .212.1616.3-D	16	16	12	125	35				
R/L .212.2020.3-D	20	20	12	150	35	912	911	3.0 - 4.0	
R/L .212.2525.3-D	25	25	12	150	-				
R/L .212.3225.3-D	32	25	12	170	-				
R/L .212.2020.4-D	20	20	12	150	35				
R/L .212.2525.4-D	25	25	12	150	-	912	911	4.0 - 5.1	
R/L .212.3225.4-D	32	25	12	170	-				
R/L .212.2020.6-D	20	20	12	150	35				
R/L .212.2525.6-D	25	25	12	150	-	912	911	5.2 - 6.0	
R/L .212.3225.6-D	32	25	12	170	-				

Bestellbeispiel:
für rechte Ausführung
R.212.1616.2-D

order-example:
righthand version
R.212.1616.2-D

SYSTEM ZTP

Einstecken mit
zweischneidigen Wendeplatten

grooving with two-cutting
edges indexable inserts

Typ .220

Klemmhalter,
Außenbearbeitung

toolholder,
external application

Stechtiefe t max. 20 mm
Spannbereich S 2.0 - 6.0 mm

depth of groove t max. 20 mm
holding capacity S 2.0 - 6.0 mm

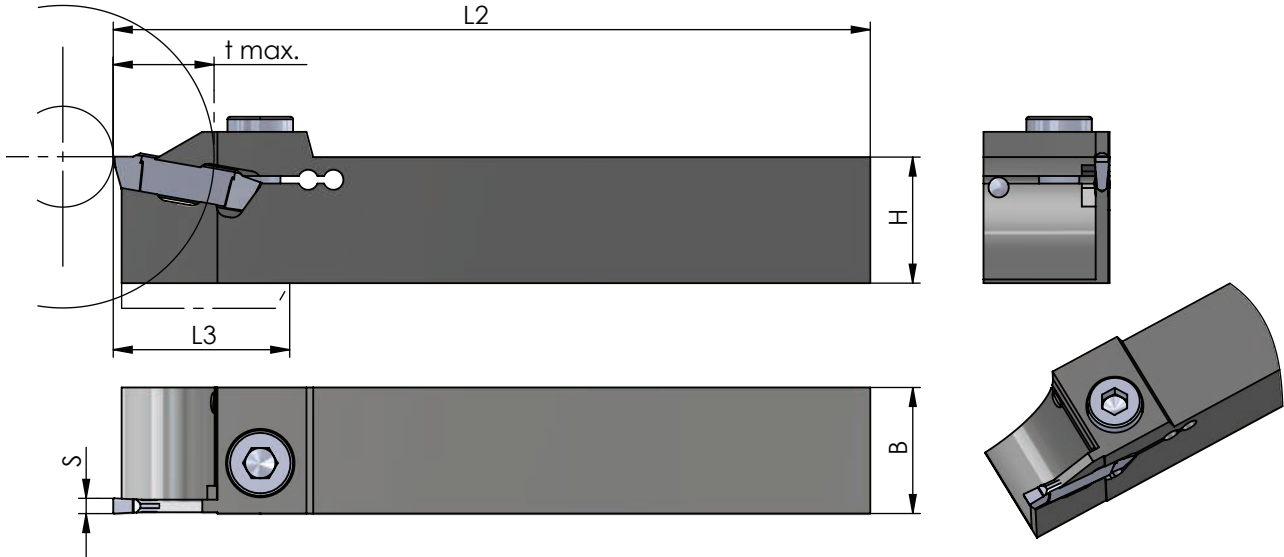

Rechts (R): wie gezeichnet
Links (L): spiegelbildlich

righthand (R): as shown
lefthand version (L): mirror image

Abmessungen in mm

dimensions in mm

Bestellnummer part number	H	B	* t max.	L2	L3	Spannschraube screw	Schraubenschlüssel wrench	Spannbereich S holding capacity S	Wende- schneidplatte S indexable insert S
								≤	
R/L .220.1616.2-D	16	16	20	125	45				
R/L .220.2020.2-D	20	20	20	150	45	912	911	2.0 - 3.0	
R/L .220.2525.2-D	25	25	20	150	-				
R/L .220.1616.3-D	16	16	20	125	45				
R/L .220.2020.3-D	20	20	20	150	45	912	911	3.0 - 4.0	
R/L .220.2525.3-D	25	25	20	150	-				
R/L .220.3225.3-D	32	25	20	170	-				
R/L .220.2020.4-D	20	20	20	150	45				
R/L .220.2525.4-D	25	25	20	150	-	912	911	4.0 - 5.1	
R/L .220.3225.4-D	32	25	20	170	-				
R/L .220.2020.6-D	20	20	20	150	45				
R/L .220.2525.6-D	25	25	20	150	-	912	911	5.2 - 6.0	
R/L .220.3225.6-D	32	25	20	170	-				

R/L .220.2-D *tmax. reduziert bei Werkstück Ø > 50
R/L .220.3-D *tmax. reduced for workpiece Ø > 50

R/L .220.4-D *tmax. reduziert bei Werkstück Ø > 100
R/L .220.6-D *tmax. reduced for workpiece Ø > 100

Bestellbeispiel:
für rechte Ausführung
R.220.1616.2-D

order-example:
righthand version
R.220.1616.2-D

SYSTEM ZTP

Einstecken mit
zweischneidigen Wendeplatten

grooving with two-cutting
edges indexable inserts

Typ .225

Klemmhalter,
Außenbearbeitung

toolholder,
external application

Stechtiefe t max. 25 mm
Spannbereich S 2.0 - 6.0 mm

depth of groove t max. 25 mm
holding capacity S 2.0 - 6.0 mm

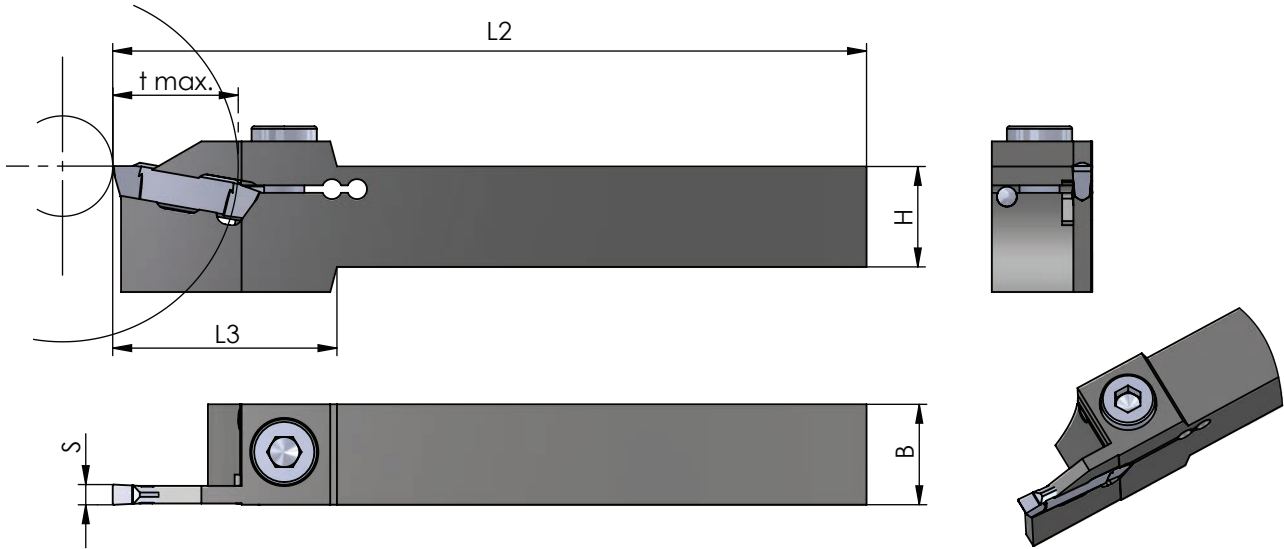

Rechts (R): wie gezeichnet
Links (L): spiegelbildlich

righthand (R): as shown
lefthand version (L): mirror image

Abmessungen in mm

dimensions in mm



Bestellnummer part number	H	B	*t max.	L2	L3	Spannschraube screw	Schraubenschlüssel wrench	Spannbereich S holding capacity S	
								≤	Wende- schneidplatte S indexable insert S
R/L .225.2020.2-D	20	20	25	150	45				
R/L .225.2525.2-D	25	25	25	150	-	912	911	2.0 - 3.0	
R/L .225.3225.2-D	32	25	25	170	-				
R/L .225.2020.3-D	20	20	25	150	45				
R/L .225.2525.3-D	25	25	25	150	-	912	911	3.0 - 4.0	
R/L .225.3225.3-D	32	25	25	170	-				
R/L .225.2020.4-D	20	20	25	150	45				
R/L .225.2525.4-D	25	25	25	150	-	912	911	4.0 - 5.1	
R/L .225.3225.4-D	32	25	25	170	-				
R/L .225.2020.6-D	20	20	25	150	45				
R/L .225.2525.6-D	25	25	25	150	-	912	911	5.2 - 6.0	
R/L .225.3225.6-D	32	25	25	170	-				

R/L .225.2-D *tmax. reduziert bei Werkstück Ø > 50
R/L .225.3-D *tmax. reduced for workpiece Ø > 50

R/L .225.4-D *tmax. reduziert bei Werkstück Ø > 100
R/L .225.6-D *tmax. reduced for workpiece Ø > 100

Bestellbeispiel:
für rechte Ausführung
R.225.2020.2-D

order-example:
righthand version
R.225.2020.2-D

SYSTEM ZTP

Einstecken mit
zweischneidigen Wendepplatten

grooving with two-cutting
edges indexable inserts

Typ .0.428

Bohrstange,
Innenbearbeitung

grooving boring bar,
internal application

D min. 46
Stechtiefe t max. 15 mm
Spannbereich S 2.0 - 6.0 mm

D min. 46
depth of groove t max. 15 mm
holding capacity S 2.0 - 6.0 mm

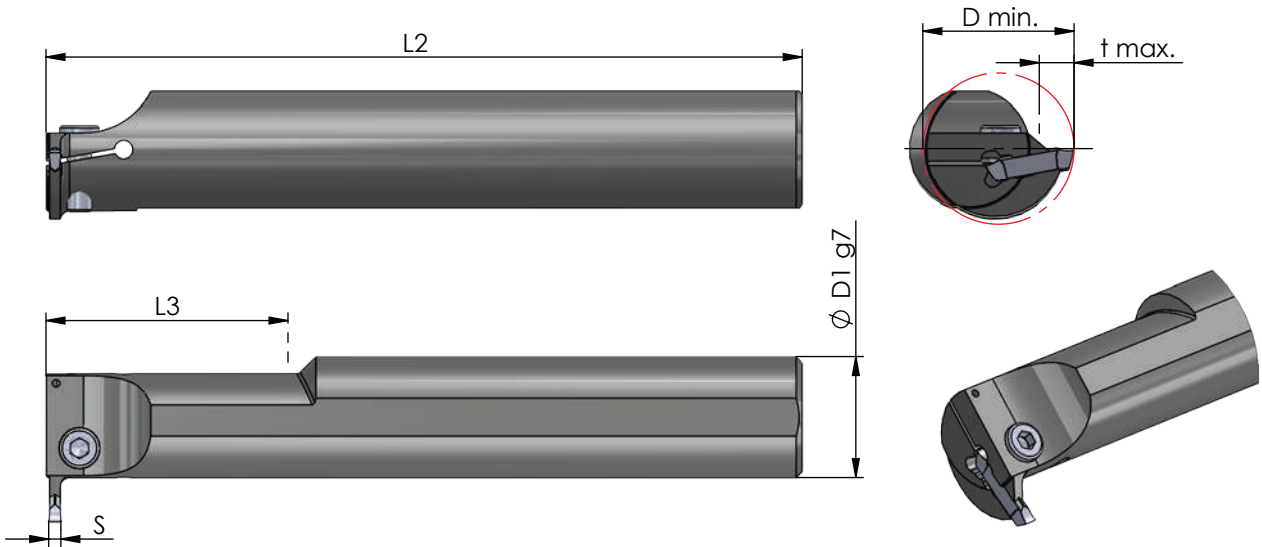

Rechts (R): wie gezeichnet
Links (L): spiegelbildlich

righthand (R): as shown
lefthand version (L): mirror image

Abmessungen in mm

dimensions in mm

Bestellnummer part number	Ø D1 g7	D min.	t max.	L2	L3	Spannschraube screw	Schrauben- schlüssel wrench	Spannbereich S holding capacity S	Wende- schneidplatte S indexable insert S
R/L .0.428.0032.2-D	32	46	11.5	200	70			2.0 - 3.0	
R/L .0.428.0040.2-D	40	50	11.5	250	80	912	911	2.0 - 3.0	
R/L .0.428.0050.2-D	50	60	15.0	250	100				
R/L .0.428.0032.3-D	32	46	11.5	200	70			3.0 - 4.0	
R/L .0.428.0040.3-D	40	50	11.5	250	80	912	911	3.0 - 4.0	
R/L .0.428.0050.3-D	50	60	15.0	250	100				
R/L .0.428.0032.4-D	32	46	11.5	200	70			4.0 - 5.1	
R/L .0.428.0040.4-D	40	50	11.5	250	80	912	911	4.0 - 5.1	
R/L .0.428.0050.4-D	50	60	15.0	250	100				
R/L .0.428.0032.6-D	32	46	11.5	200	70			5.2 - 6.0	
R/L .0.428.0040.6-D	40	50	11.5	250	80	912	911	5.2 - 6.0	
R/L .0.428.0050.6-D	50	60	15.0	250	100				

Bestellbeispiel:
für rechte Ausführung
R.0.428.0032.2-D

order-example:
righthand version
R.0.428.0032.2-D

SYSTEM ZTP

Einstecken mit
zweischneidigen Wendeplatten

grooving with two-cutting
edges indexable inserts

Typ .280

Klemmhalter,
Axialbearbeitung

toolholder,
face grooving

D min. 40
Stechtiefe t max. 8 mm
Spannbereich S 4.0 - 6.0 mm

D min. 40
depth of groove t max. 8 mm
holding capacity S 4.0 - 6.0 mm

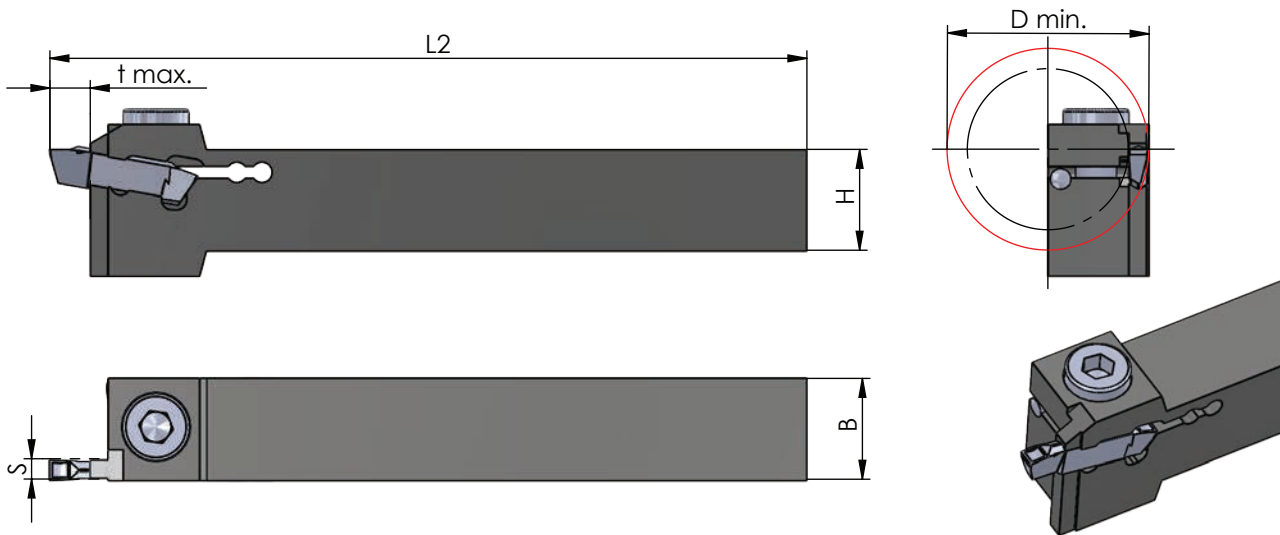

Rechts (R): wie gezeichnet
Links (L): spiegelbildlich

righthand (R): as shown
lefthand version (L): mirror image

Abmessungen in mm

dimensions in mm



Bestellnummer part number	H	B	D min.	t max.	L2	Spannschraube screw	Schrauben- schlüssel wrench	Spannbereich S holding capacity S		Wende- schneidplatte S indexable insert S
								<	=	
R/L .280.2020.4-D	20	20	40	8	150	912	911	<	=	4.0 - 5.1
R/L .280.2525.4-D	25	25	40	8	150					5.2 - 6.0
R/L .280.2020.6-D	20	20	40	8	150	912	911	<	=	4.0 - 5.1
R/L .280.2525.6-D	25	25	40	8	150					5.2 - 6.0

Bestellbeispiel:
für rechte Ausführung
R.280.2020.4-D

order-example:
righthand version
R.280.2020.4-D

SYSTEM ZTP

Einstecken mit
zweischneidigen Wendepplatten

grooving with two-cutting
edges indexable inserts

Typ .281

Klemmhalter,
Axialbearbeitung

toolholder,
face grooving

D min. 40
Stechtiefe t max. 8.5 mm
Spannbereich S 4.0 - 6.0 mm

D min. 40
depth of groove t max. 8.5 mm
holding capacity S 4.0 - 6.0 mm

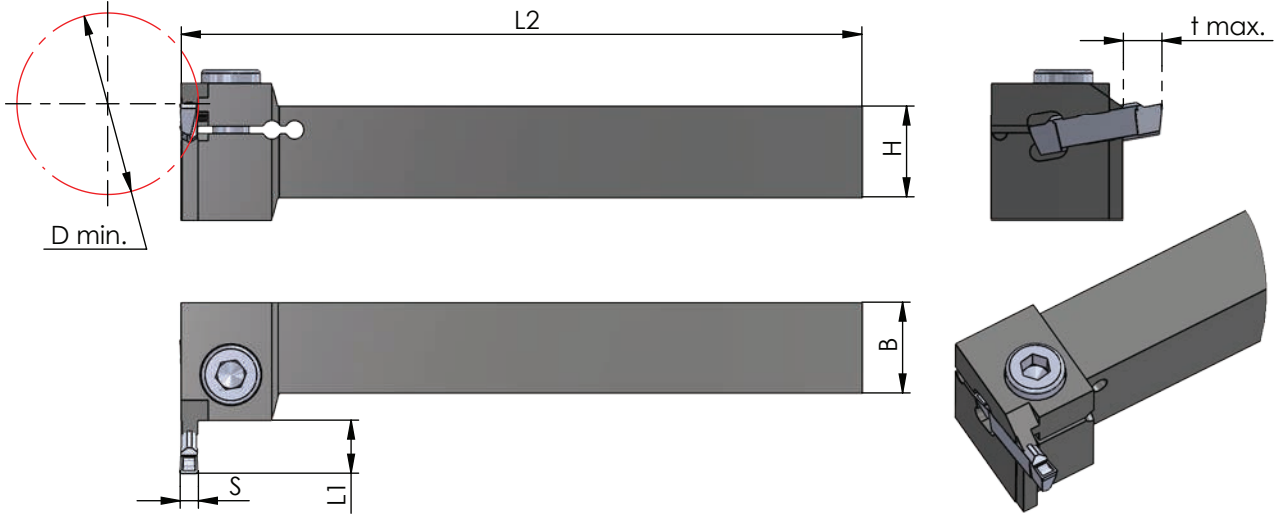

Rechts (R): wie gezeichnet
Links (L): spiegelbildlich

righthand (R): as shown
lefthand version (L): mirror image

Abmessungen in mm

dimensions in mm

Bestellnummer part number	H	B	D min.	t max.	L2	L1	Spannschraube screw	Schrauben- schlüssel wrench	Spannbereich S holding capacity S		Wende- schneidplatte S indexable insert S
									<	<	
R/L .281.2020.4-D	20	20	40	8.5	150	11	912	911	4.0 - 5.1		
R/L .281.2525.4-D	25	25	40	8.5	150	11			5.2 - 6.0		
R/L .281.2020.6-D	20	20	40	8.5	150	11	912	911	4.0 - 5.1		
R/L .281.2525.6-D	25	25	40	8.5	150	11			5.2 - 6.0		

Bestellbeispiel:
für rechte Ausführung
R.281.2020.4-D

order-example:
righthand version
R.281.2020.4-D

SYSTEM ZTP

Einstecken mit
zweischneidigen Wendeplatten

grooving with two-cutting
edges indexable inserts

Typ Stechdrehen10

Wendeschneidplatte,
mit runder Spannutt

indexable insert,
with round chipbreaker

Stechbreite S 2.0 - 6.0 mm

width of groove S 2.0 - 6.0 mm

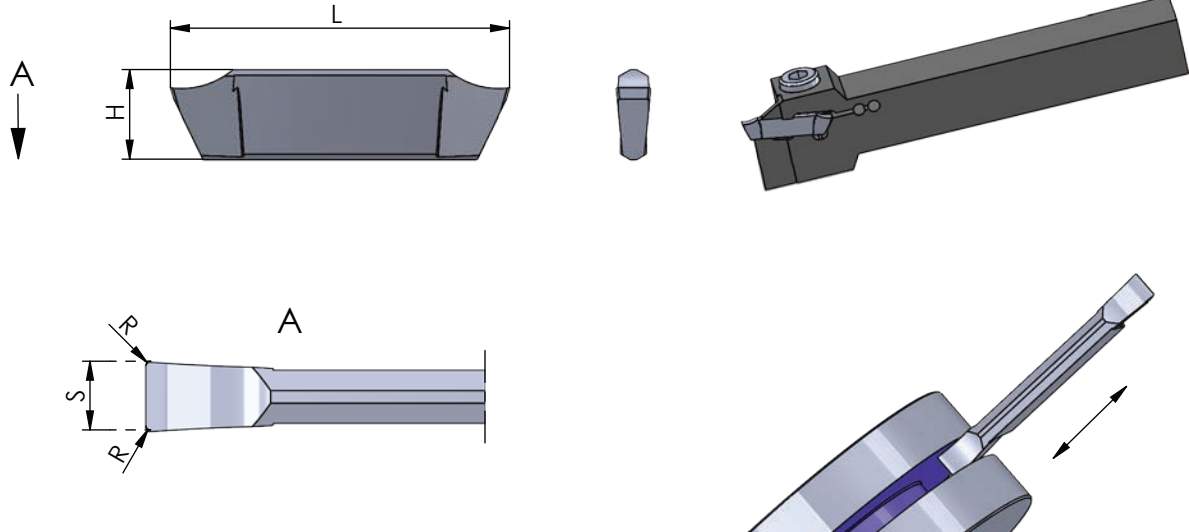

Wendeschneidplatten sind in
rechten und linken Klemmhaltern
sowie Bohrstängen verwendbar

inserts can be used in RH and LH
toolholders as well as in boring
bars

Abmessungen in mm

dimensions in mm



Bestellnummer part number	S +0.05	H	R	L					Klemmhalter Typ toolholder type
					K10F	CN45F	AL41F	P07C	
ZTP.0200.10	2.0	7.9	0.2	29.9	●	●	●		R/L .212.2-D R/L .220.2-D R/L .225.2-D R/L .0.428.2-D
ZTP.0300.10	3.0	7.9	0.2	29.9	●	●	●		R/L .212.3-D R/L .220.3-D R/L .225.3-D R/L .0.428.3-D
ZTP.0400.10	4.0	7.9	0.2	29.9	●	●	●		R/L .212.4-D R/L .220.4-D
ZTP.0500.10	5.0	7.9	0.2	29.9	●	●	●		R/L .225.4-D R/L .0.428.4-D
ZTP.0600.10	6.0	7.5	0.4	29.9	●	●	●		R/L .212.6-D R/L .220.6-D R/L .225.6-D R/L .0.428.6-D

Weitere HM Sorten können Sie in der Sorten-
übersicht im Kapitel "Technische Hinweise" und
der Preisliste finden.

Bestellbeispiel:
für Sorte AL41F:
ZTP.0200.10/AL41F

More carbide grades you can find in the grades
summary in the chapter "technical instructions"
and in the price list.

order-example:
grade AL41F:
ZTP.0200.10/AL41F

SYSTEM ZTP

Einstecken mit
zweischneidigen Wendeplatten

grooving with two-cutting
edges indexable inserts

Typ Stechdrehen20

Wendeschneidplatte,
mit ebener Spanfläche

indexable insert,
with flat chipbreaker

Stechbreite S 2.0 - 6.0 mm

width of groove S 2.0 - 6.0 mm

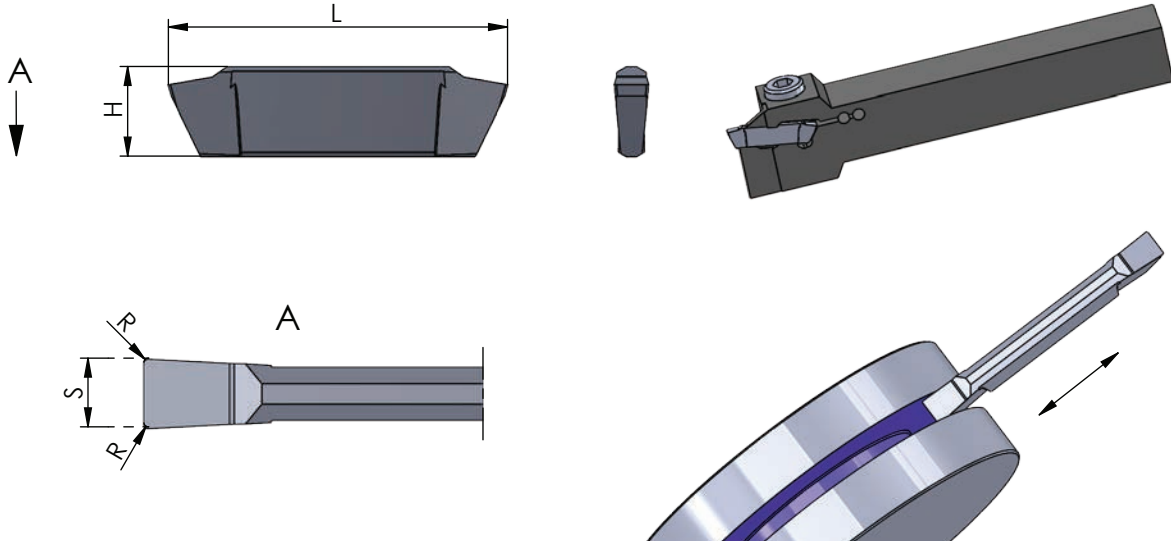

Wendeschneidplatten sind in
rechten und linken Klemmhaltern
sowie Bohrstängen verwendbar

inserts can be used in RH and LH
toolholders as well as in boring
bars

Abmessungen in mm

dimensions in mm

Bestellnummer part number	S +0.05	H	R	L	K10F	CN45F	AL41F	P07C	Klemmhalter Typ	toolholder type
ZTP.0200.20	2.0	7.9	0.2	29.9	●	●	●		R/L .212.2-D R/L .220.2-D R/L .225.2-D R/L .0.428.2-D	
ZTP.0300.20	3.0	7.9	0.2	29.9	●	●	●		R/L .212.3-D R/L .220.3-D R/L .225.3-D R/L .0.428.3-D	
ZTP.0400.20	4.0	7.9	0.2	29.9	●	●	●		R/L .212.4-D R/L .220.4-D	
ZTP.0500.20	5.0	7.9	0.2	29.9	●	●	●		R/L .225.4-D R/L .0.428.4-D	
ZTP.0600.20	6.0	7.5	0.4	29.9	●	●	●		R/L .212.6-D R/L .220.6-D R/L .225.6-D R/L .0.428.6-D	

Weitere HM Sorten können Sie in der Sorten-
übersicht im Kapitel "Technische Hinweise" und
der Preisliste finden.

More carbide grades you can find in the grades
summary in the chapter "technical instructions"
and in the price list.

Bestellbeispiel:
für Sorte AL41F:
ZTP.0200.20/AL41F

order-example:
grade AL41F:
ZTP.0200.20/AL41F

SYSTEM ZTP

Einstecken mit
zweischneidigen Wendeplatten

grooving with two-cutting
edges indexable inserts

Typ Stechdrehen30

Wendeschneidplatte,
mit Spanformer

indexable insert,
with chipformer

Stechbreite S 2.0 - 6.0 mm

width of groove S 2.0 - 6.0 mm

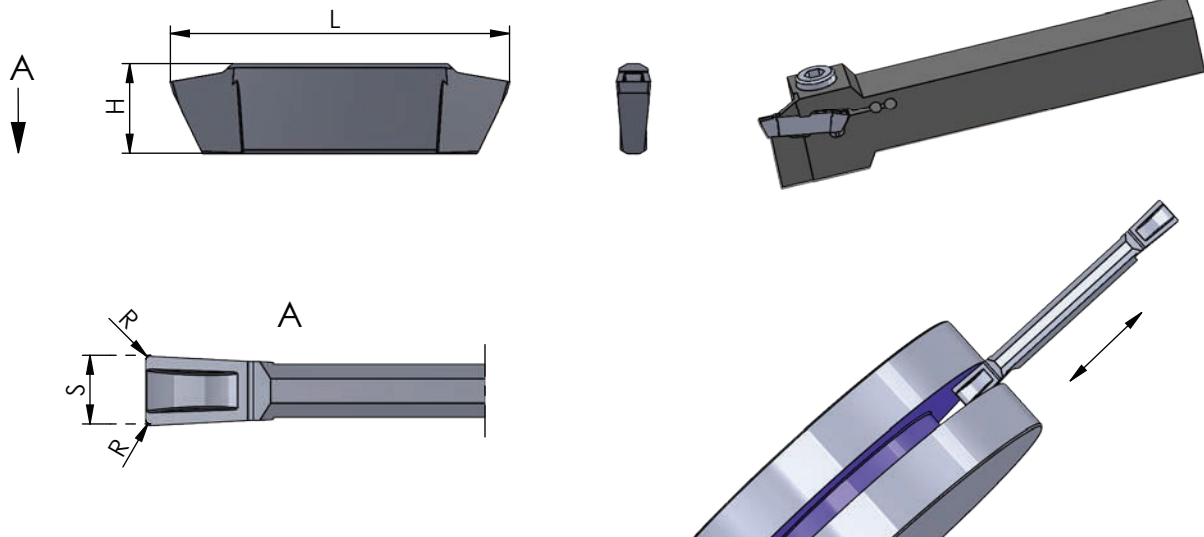

Wendeschneidplatten sind in
rechten und linken Klemmhaltern
sowie Bohrstängen verwendbar

inserts can be used in RH and LH
toolholders as well as in boring
bars

Abmessungen in mm

dimensions in mm



Bestellnummer part number	S +0.05	H	R	L					Klemmhalter Typ toolholder type
					K10F	CN45F	AL41F	P07C	
ZTP.0200.30	2.0	7.9	0.2	29.9	●	●	●		R/L .212. 2-D R/L .220. 2-D R/L .225. 2-D R/L .0.428. 2-D
ZTP.0300.30	3.0	7.9	0.2	29.9	●	●	●		R/L .212. 3-D R/L .220. 3-D R/L .225. 3-D R/L .0.428. 3-D
ZTP.0400.30	4.0	7.9	0.2	29.9	●	●	●		R/L .212. 4-D R/L .220. 4-D
ZTP.0500.30	5.0	7.9	0.2	29.9	●	●	●		R/L .225. 4-D R/L .0.428. 4-D
ZTP.0600.30	6.0	7.5	0.4	29.9	●	●	●		R/L .212. 6-D R/L .220. 6-D R/L .225. 6-D R/L .0.428. 6-D

Weitere HM Sorten können Sie in der Sorten-
übersicht im Kapitel "Technische Hinweise" und
der Preisliste finden.

Bestellbeispiel:
für Sorte AL41F:
ZTP.0200.30/AL41F

More carbide grades you can find in the grades
summary in the chapter "technical instructions"
and in the price list.

order-example:
grade AL41F:
ZTP.0200.30/AL41F

SYSTEM ZTP

Einstecken mit
zweischneidigen Wendeplatten

grooving with two-cutting
edges indexable inserts

Typ Stechdrehen ZTP.R

Wendeschneidplatte,
mit Vollradius
und runder Spannutt

indexable insert,
with full radius
and round chipbreaker

Stechbreite S 2.0 - 6.0 mm

width of groove S 2.0 - 6.0 mm

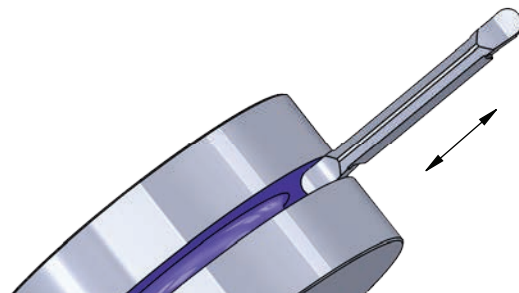
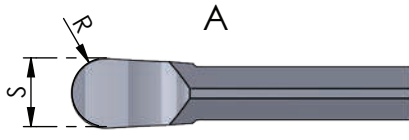
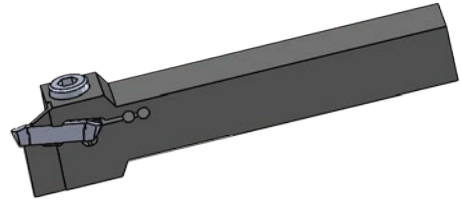
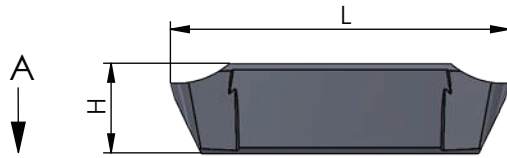

Wendeschneidplatten sind in
rechten und linken Klemmhaltern
sowie Bohrstängen verwendbar

inserts can be used in RH and LH
toolholders as well as in boring
bars

Abmessungen in mm

dimensions in mm

Bestellnummer part number	S +0.05	R	H	L	Klemmhalter Typ toolholder type				
					K10F	CN45F	AL41F	P07C	
ZTP.R010.20	2.0	1.0	7.9	29.9	●	●			R/L .212. 2-D R/L .220. 2-D R/L .225. 2-D R/L .0.428. 2-D
ZTP.R015.30	3.0	1.5	7.9	29.9	●	●			R/L .212. 3-D R/L .220. 3-D R/L .225. 3-D R/L .0.428. 3-D
ZTP.R020.40	4.0	2.0	7.9	29.9	●		●		R/L .212. 4-D R/L .220. 4-D
ZTP.R025.50	5.0	2.5	7.9	29.9			●		R/L .225. 4-D R/L .0.428. 4-D
ZTP.R030.60	6.0	3.0	7.5	29.9			●		R/L .212. 6-D R/L .220. 6-D R/L .225. 6-D R/L .0.428. 6-D

Weitere HM Sorten können Sie in der Sorten-
übersicht im Kapitel "Technische Hinweise" und
der Preisliste finden.

More carbide grades you can find in the grades
summary in the chapter "technical instructions"
and in the price list.

Bestellbeispiel:
für Sorte AL41F:
ZTP.R010.20/AL41F

order-example:
grade AL41F:
ZTP.R010.20/AL41F

SYSTEM ZTP

Einstecken mit
zweischneidigen Wendeplatten

grooving with two-cutting
edges indexable inserts

Typ Stechdrehen / Abstechen

Wendeschneidplatte,
mit Spanformer

indexable insert,
with chipformer,
for parting off

Stechbreite S 2.0 - 4.0 mm

width of groove S 2.0 - 4.0 mm

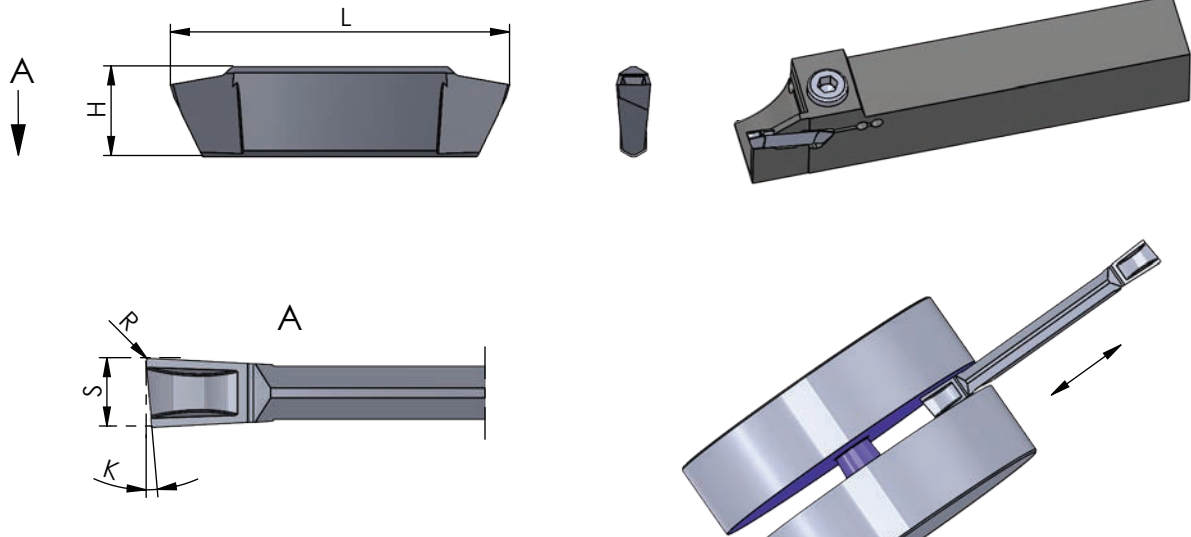

Rechts (R): wie gezeichnet
Links (L): spiegelbildlich

Wendeschneidplatten sind in
rechten und linken Klemmhaltern
verwendbar.
Abmessungen in mm

righthand version (R): as shown
lefthand version (L): mirror image

inserts can be used in RH and LH
toolholders

dimensions in mm



Bestellnummer part number	S ±0.05	K	R	H	L	Klemmhalter Typ toolholder type				
						K10F	CN45F	AL41F	P07C	
R/L .ZTP.5200.30	2.0	5°	0.2	7.9	29.9	●	●	●		R/L .12. 2-D R/L .220. 2-D R/L .225. 2-D
R/L .ZTP.5300.30	3.0	5°	0.2	7.9	29.9	●	●	●		R/L .12. 3-D R/L .220. 3-D R/L .225. 3-D
R/L .ZTP.5400.30	4.0	5°	0.2	7.9	29.9	●	●	●		R/L .12. 4-D R/L .220. 4-D R/L .225. 4-D

Weitere HM Sorten können Sie in der Sorten-
übersicht im Kapitel "Technische Hinweise" und
der Preisliste finden.

Bestellbeispiel:
für rechte Ausführung und Sorte:
R.ZTP.5200.30/AL41F

More carbide grades you can find in the grades
summary in the chapter "technical instructions"
and in the price list.

order-example:
righthand version and grade:
R.ZTP.5200.30/AL41F

SYSTEM ZTP

Einstecken mit
zweischneidigen Wendeplatten

grooving with two-cutting
edges indexable inserts

Typ Stechdrehen / Längsdrehen

Wendeschneidplatte,
mit Spanformer

indexable insert,
with chipformer,
grooving and turning

Stechbreite S 3.0 - 6.0 mm

width of groove S 3.0 - 6.0 mm

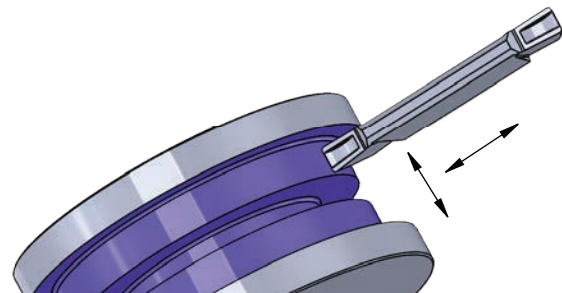
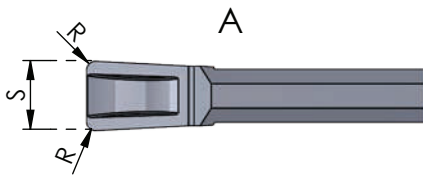
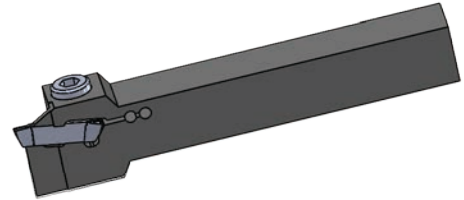
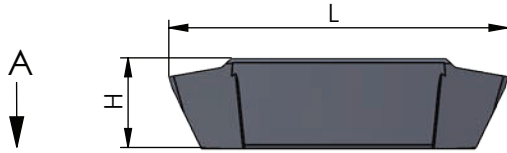

Wendeschneidplatten sind in
rechten und linken Klemmhaltern
sowie Bohrstängen verwendbar

inserts can be used in RH and LH
toolholders as well as in boring
bars

Abmessungen in mm

dimensions in mm

Bestellnummer part number	S +0.05	H	R	L	K10F	CN45F	AL41F	P07C	Klemmhalter Typ	toolholder type
ZTP.0300.34	3.0	7.9	0.4	29.9	●	●	●		R/L .212. 3-D R/L .220. 3-D R/L .225. 3-D R/L .0.428. 3-D	
ZTP.0400.34	4.0	7.9	0.4	29.9	●	●	●		R/L .212. 4-D R/L .220. 4-D R/L .225. 4-D R/L .0.428. 4-D	
ZTP.0500.34	5.0	7.9	0.4	29.9	●	●	●		R/L .212. 6-D R/L .220. 6-D R/L .225. 6-D R/L .0.428. 6-D	
ZTP.0600.34	6.0	7.5	0.8	29.9	●	●	●		R/L .212. 3-D R/L .220. 3-D R/L .225. 3-D R/L .0.428. 3-D	

Weitere HM Sorten können Sie in der Sorten-
übersicht im Kapitel "Technische Hinweise" und
der Preisliste finden.

More carbide grades you can find in the grades
summary in the chapter "technical instructions"
and in the price list.

Bestellbeispiel:
für Sorte AL41F:
ZTP.0300.34/AL41F

order-example:
grade AL41F:
ZTP.0300.34/AL41F

SYSTEM ZTP

Einstecken mit
zweischneidigen Wendeplatten

grooving with two-cutting
edges indexable inserts

Typ Stechdrehen / Axialbearbeitung

Wendeschneidplatte,
mit Spanformer

indexable insert,
with chipformer,
face grooving

D min. 40 mm
Stechbreite S 4.0 - 6.0 mm

D min. 40 mm
width of groove S 4.0 - 6.0 mm

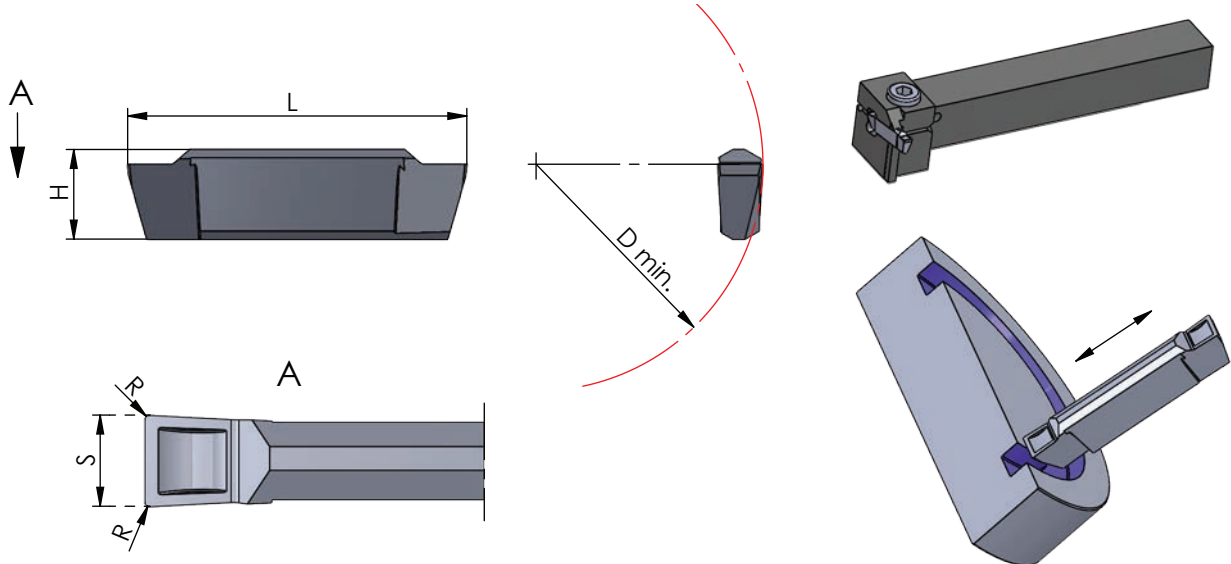

Rechts (R): wie gezeichnet
Links (L): spiegelbildlich

Wendeschneidplatten sind in
rechten und linken Klemmhaltern
verwendbar
Abmessungen in mm

righthand version (R): as shown
lefthand version (L): mirror image

inserts can be used in RH and LH
toolholders

dimensions in mm



Bestellnummer part number	S +0.05	H	R	L	D min.	Klemmhalter Typ toolholder type			
						K10F	CN45F	AL41F	P07C
R/L .ZTP.4040.34	4.0	7.9	0.2	29.9	40	●	●	●	
R/L .ZTP.4050.34	5.0	7.9	0.4	29.9	40	●	●	●	R/L .280.4-D R/L .281.4-D
R/L .ZTP.4060.34	6.0	7.5	0.4	29.9	40		●	●	R/L .280.6-D R/L .281.6-D

Weitere HM Sorten können Sie in der Sorten-
übersicht im Kapitel "Technische Hinweise" und
der Preisliste finden.

Bestellbeispiel:
für rechte Ausführung und Sorte:
R.ZTP.4040.34/AL41F

More carbide grades you can find in the grades
summary in the chapter "technical instructions"
and in the price list.

order-example:
righthand version and grade:
R.ZTP.4040.34/AL41F

SYSTEM DED / ZTP

Einstecken mit
zwei- und dreischneidigen
Wendeplatten

grooving with
two and three-cutting edges
indexable inserts

Technische Hinweise

Hartmetallsorten und Beschichtungen

Technical instructions,
carbide grades and coatings

K10F

Universell einsetzbares Feinkornhartmetall mit guter Verschleißfestigkeit. Unbeschichtet geeignet für Anwendungen mit niedrigen und mittleren Schnittgeschwindigkeiten, sowie die Bearbeitung von Nicht-eisenmetallen.

All purpose micrograin carbide with good abrasion resistance. Uncoated for applications with low or medium cutting speeds and machining of non-ferrous materials.

CBN

Zähe CBN-Sorte für Anwendungen mit niedrigen Schnittgeschwindigkeiten. Geeignet für gehärtete Stähle, unterbrochene Schnitte und Grauguss.

Ductile CBN grade for applications with lower cutting speed. Suitable for hardened steel, interrupted cuts and cast iron.

CN45F

Universell einsetzbare PVD-TIN-Beschichtung. Diese Allround-Sorte ist für niedrige und mittlere Schnittgeschwindigkeiten mit Einschränkung bei NE-Metallen

PVD-TIN coating - all purpose, all around grade is suitable for low and medium cutting speed with restrictions on non-ferrous materials.

AL41F

Sehr universell einsetzbare TIALN-Beschichtung mit hoher Temperaturbeständigkeit bei hoher Härte. Sehr gut geeignet auch für NE-Metalle.

TIALN coating - very universal with a high resistance to high temperature and hardness. Very suitable also for non-ferrous metals.

PD2F

Beschichtung für den universellen Einsatz bei niedrigen und mittleren Schnittgeschwindigkeiten.

Coating for universal use with medium and low speed.

XC2A

Beschichtung mit einer excellenten Warmhärte, Oxidationsbeständigkeit und thermischen Isolationsfähigkeit. Ideal für Hartzerspannung >60HRC

Coating with excellent hot hardness, high oxidation resistance and thermal insulation capacity. Perfect for hard machining >60 HRC.

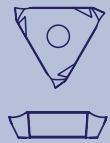

SYSTEM DED / ZTP

Einstecken mit
zwei- und dreischneidigen
Wendeplatten

grooving with
two and three-cutting edges
indexable inserts

Technische Hinweise

Hartmetallsorten und Beschichtungen

Technical instructions,
carbide grades and coatings

P01C

Beschichtung für die Bearbeitung in zähen Materialien bei niedrigen und mittleren Schnittgeschwindigkeiten.

Coating for the processing in tough material with medium or low cutting speed

P03C

Beschichtung für die Bearbeitung von schwer zerspanbaren Materialien. Sehr gut auch für die Trockenbearbeitung geeignet.

Coating for materials which are difficult to machine. Perfect to use for dry machining.

P07C

Beschichtung für die Bearbeitung von Titan, Edelstahl und Molybdän.

Coating to machine titanium, stainless steel and molybdenum.

P18C

Universell einsetzbare Hochleistungsschicht mit hoher Oxidationsbeständigkeit, Verschleißfestigkeit und Warmhärte.

Very universal high performance coating with high oxidation resistance, wear resistance and hot hardness resistance.

NEME

Beschichtung für die Bearbeitung von Aluminium, Al-Legierungen, NE-Metallen und Composite-Werkstoffen.

Coating for machining aluminium, alloys, non-ferrous metals and composite materials.



SYSTEM DED / ZTP

Einstechen mit
zwei- und dreischneidigen
Wendepplatten

grooving with
two and three-cutting edges
indexable inserts

Technische Hinweise

Schnittdaten

Technical instructions,
cutting data

	Werkstoff	Festigkeit	Werkstoff-Nr	Werkstoffbezeichnung	Werkstoff-Nr	
P	Allgemeiner Baustahl	< 800 N/mm ²	1.0037	St37-2	1.0570	
	Automatenstahl	< 800 N/mm ²	1.0718	9SMnPb28	1.0727	
	Einsatzstahl unlegiert	< 800 N/mm ²	1.0401	C15	1.0481	
	Einsatzstahl legiert	< 1000 N/mm ²	1.7331	16MnCr5 (EC80)	1.7015	
	Vergütungsstahl unlegiert	< 850 N/mm ²	1.0503	C45	1.1191	
	Vergütungsstahl unlegiert	< 1000 N/mm ²	1.0601	C60	1.1221	
	Vergütungsstahl legiert	< 800 N/mm ²	1.5131	50MnSi4	1.7030	
	Vergütungsstahl legiert	< 1300 N/mm ²	1.5755	31NiCr14	1.7033	
	Stahlguss	< 850 N/mm ²	0.9650	G-X260Cr27	1.6750	
	Nitrierstahl	< 1000 N/mm ²	1.8504	34CrAl6	1.8507	
	Nitrierstahl	< 1200 N/mm ²	1.8515	31CrMo12	1.8523	
	Wälzlagerstahl	< 1200 N/mm ²	1.3505	100Cr6 (W3)	1.3543	
	Federstahl	< 1200 N/mm ²	1.5026	55Si7	1.7176	
	Schnellarbeitsstahl	< 1300 N/mm ²	1.3344	S 6-5-3	1.3255	
M	Werkzeugstahl für Kaltarbeit	< 1300 N/mm ²	1.2312	40CrMnMoS8 6	1.2379	
	Werkzeugstahl für Warmbeit	< 1300 N/mm ²	1.2343	X38CrMoV 5 1	1.2767	
	Stahl und Stahlguss rostfrei geschwefelt	< 850 N/mm ²	1.4305	X8CrNiS18 9	1.4105	
	Nichtrostender Stahl, ferritisch	< 750 N/mm ²	1.4510	X3CrTi17	1.4528	
	Nichtrostender Stahl, martensitisch	< 900 N/mm ²	1.4034	X46Cr13	1.4116	
	Nichtrost. Stahl, ferritisch/martensit.	<1100 N/mm ²	1.4313	X3CrNi13-4	1.4028	
	Nichtrost. Stahl, austenitisch/ferritisch	< 850 N/mm ²	1.4460	X8CrNiMo27 5	1.4821	
	Nichtrostender Stahl, austenitisch	< 750 N/mm ²	1.4301	X5CrNi18-10	1.4571	
	Hitzebeständig	< 1100 N/mm ²	1.4747	X80CrNiSi20	1.4876	
	Grauguss mit Lammellengraphit	100-350N/mm ²	0.6010	GG10	0.6025	
	Grauguss mit Lammellengraphit	300-1000N/mm ²	0.6030	GG30	0.6045	
	Kugelgraphitguss	300-500N/mm ²	0.7040	GGG40	0.7050	
	Kugelgraphitguss	550-800N/mm ²	0.7060	GGG60	0.7080	
	K	Temperguss weis	350-450N/mm ²	0.8035	GTW35	0.8045
Temperguss weis		500-650N/mm ²	0.8055	GTW55	0.8065	
Temperguss schwarz		350-450N/mm ²	0.8135	GTS35	0.8145	
Temperguss schwarz		500-700N/mm ²	0.8155	GTS55	0.8170	
N		Aluminium (unlegiert, niedrig legiert)	< 350 N/mm ²	3.0255	Al99,5	3.3308
		Aluminiumlegierungen < 0,5% Si	< 500 N/mm ²	3.0515	AlMn1	3.1355
		Aluminiumlegierungen 0,5-10% Si	< 400 N/mm ²	3.2152	GD-AlSi6Cu4	3.2373
		Aluminiumlegierungen 10-15% Si	< 400 N/mm ²	3.2381	G-AlSi10Mg	3.5562
		Aluminiumlegierungen > 15% Si	< 400 N/mm ²		G-AlSi17Cu4	
		Kupfer (unlegiert, niedrig legiert)	< 350 N/mm ²	2.0060	E-Cu57	2.0090
		Kupfer-Knetlegierungen	< 700 N/mm ²	2.0240	CuZn15	2.0265
		Kupfer-Sonderlegierungen	< 200 HB	2.0916	CuAl5	2.1525
		Kupfer-Sonderlegierungen	< 300HB	2.0978	CuAl11Ni6Fe5	
		Kupfer-Sonderlegierungen	> 300 HB	2.1247	CuBe2F125	
	Messing kurzspanend, Bronze, Rotguss	< 600 N/mm ²	2.0360	CuZn40 (Ms60)	2.0380	
	Messing langspanend	< 600 N/mm ²	2.0335	CuZn36 (Ms63)	2.1293	
	Thermoplaste			Delrin, Hostalen		
	Duroplaste			Ferrozell, Bakelit		
	Faserverstärkte Kunststoffe			GFK (Glasfaserverstärkt)		
	Magnesium und Magnesiumlegierungen	< 850 N/mm ²	3.5200	M2, MgMn2	3.5612	
	Graphit			C8000, R8500X		
	Wolfram und Wolframlegierungen			W-NiFe (Densimet W)		
	Molybdän und Molybdänlegierungen			Mo , Mo-50Re		
	S	Reinnickel		1.3911	RNi24	1.3927
Nickellegierungen			1.3912	Ni36 (Invar)	1.3924	
Nickellegierungen		< 850 N/mm ²	2.4360	S-NiCu 30 Fe		
Nickel-Chromlegierungen			2.4886	SG-NiMo16Cr16W	2.4610	
Nickel- und Kobaltlegierungen		< 1300 N/mm ²	2.4632	NiCr20Co18Ti	2.4631	
Nickel- und Kobaltlegierungen		< 1300 N/mm ²	2.4634	NiCo20Cr15MoAlTi	2.4654	
Hochwärmefeste Legierungen		< 1300 N/mm ²		Hardox 400	1.4939	
Nickel-Kobalt-(Chrom-)legierungen		< 1400 N/mm ²	2.4806	SG-NiCr20Nb, Inconel 82	2.4851	
Reintitan		< 900 N/mm ²	3.7025	Ti99,8	3.7034	
Titanlegierungen		< 700 N/mm ²	3.7114	TiAl5Sn2	3.7174	
Titanlegierungen		< 1200 N/mm ²	3.7164	TiAl5V4	3.7144	
H	Stahl gehärtet	< 45 HRc				
		46-55HRc				
		56-60 HRc				
		61-65 HRc				
		65-70 HRc				

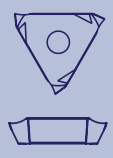

SYSTEM DED / ZTP

Einstecken mit
zwei- und dreischneidigen
Wendepplatten

grooving with
two and three-cutting edges
indexable inserts

Technische Hinweise

Schnittdaten

Technical instructions,
cutting data



Werkstoffbezeichnung	Werkstoff-Nr	Werkstoffbezeichnung	Vc K10F (m/min.)	Vc AL41F (m/min.)	Vc CN45F (m/min.)	f DED (mm/U)	f ZTP (mm/U)
St52-3	1.0060	St60-2		80-200	100-220	0,03-0,1	0,05-0,2
45S20	1.0757	46SPb2		80-200	100-220	0,03-0,1	0,05-0,2
17Mn4	1.1141	C15E (CK15)		80-200	100-180	0,03-0,1	0,05-0,2
13Cr3 (EC60)	1.5919	15CrNi6		80-160	100-180	0,03-0,1	0,05-0,2
Ck45	1.0535	C55		80-160	80-140	0,03-0,1	0,05-0,2
Ck60	1.0540	C50		80-160	80-140	0,03-0,1	0,05-0,2
28Cr4	1.7225	42CrMo4		80-160	80-140	0,03-0,1	0,05-0,2
34Cr4	1.3565	48CrMo4		80-150	80-140	0,03-0,1	0,05-0,2
GS-20NiCrMo3 7	1.6582	GS-34 CrNiMo 6		80-200	100-180	0,03-0,1	0,05-0,2
34AlMo5	1.8509	41CrAlMo7		70-140	60-120	0,03-0,07	0,05-0,15
39CrMoV19 3	1.8550	34 CrAlNi 7		70-140	60-120	0,03-0,07	0,05-0,15
X192CrMo17	1.3520	100 CrMn 6 (W4)		70-140	60-120	0,03-0,07	0,05-0,15
55Cr3	1.7701	51CrMoV4		40-60		0,03-0,07	0,05-0,15
S 18-1-2-5	1.3294	PMH56-5-3-8; ASP30		40-60		0,03-0,07	0,05-0,15
X155CrVMo12 1	1.2316	X38CrMo16; RAMAX		40-60		0,03-0,07	0,05-0,15
X45NiCrMo4	1.2842	90MnCrV8		40-60		0,03-0,07	0,05-0,15
X4CrMoS18	1.4107	GX8CrNi12	40-80	80-160	80-160	0,02-0,06	0,03-0,1
X105CrCoMo18 2	1.4016	X6Cr17	40-80	80-160	80-160	0,02-0,06	0,03-0,1
X50CrMoV15	1.4106	X2CrMoSi18-2-1	40-80	80-160	80-160	0,02-0,06	0,03-0,1
X30Cr13	1.4104	X14CrMo517	30-65	20-85	20-90	0,02-0,06	0,03-0,1
X20CrNiSi25 4	1.4462	X2CrNiMoN22-5-3 (Duplex)	30-65	20-75	20-90	0,02-0,06	0,03-0,1
X6CrNiMoTi17 12 2	1.4449	X3CrNiMo18-12-3	30-65	20-65	20-90	0,02-0,06	0,03-0,1
X10NiCrAlTi32-21	1.4825	GX25CrNiSi18-9	30-65	20-65	20-90	0,02-0,06	0,03-0,01
GG25			30-110	30-180	30-160	0,03-0,1	0,05-0,2
GG45			30-90	30-150	30-140	0,03-0,1	0,05-0,2
GGG50			25-110	30-180	30-160	0,03-0,1	0,05-0,2
GGG80			25-80	30-120	30-100	0,03-0,1	0,05-0,2
GTW45			20-40	30-90	30-80	0,03-0,1	0,05-0,2
GTW65			20-40	20-80	20-70	0,03-0,1	0,05-0,2
GTS45			20-40	30-90	30-80	0,03-0,1	0,05-0,2
GTS70			20-40	20-80	20-70	0,03-0,1	0,05-0,2
Al99,9Mg0,5	3.0256	E-Al H	120-500	120-600		0,05-0,12	0,08-0,25
AlCuMg2	3.3315	AlMg1	120-500	120-600		0,05-0,12	0,08-0,25
GD-ALSi9Mg	3.2134	GD-ALSi5Cu1Mg	100-400	100-450		0,05-0,12	0,08-0,25
G-MgAl6	3.2525	S-ALSi12	70-250	70-300		0,05-0,12	0,08-0,25
G-ALSi25CuNiMg		G-ALSi21CuNiMg	60-140	60-150		0,05-0,12	0,08-0,25
SF-Cu	2.1522	CuSi2Mn	60-140	60-150		0,05-0,12	0,08-0,25
CuZn30	2.0321	CuZn37	100-160	100-180		0,05-0,12	0,08-0,25
CuSi3Mn		Ampco 8-16	90-160	90-180		0,05-0,12	0,08-0,25
		Ampco 18-26	80-160	80-180		0,05-0,12	0,08-0,25
		Ampco M-4	80-160	80-180		0,05-0,12	0,08-0,25
CuZn39Pb2 (Ms58)	2.0410	CuZn44Pb2	120-200	120-220		0,05-0,12	0,08-0,25
CuCrZr	2.1080	CuSn6Zn6	70-140	70-150		0,05-0,12	0,08-0,25
Makrolon, Novodur		Acrylglas, Polystyrol	80-160	80-180		0,05-0,12	0,08-0,25
Pertinax		Resopal	80-160	80-180		0,05-0,12	0,08-0,25
CFK (Kohlefaserverstärkt)		AFK (Amidfaserverstärkt)		80-180		0,05-0,12	0,08-0,25
MgAl6Zn1	3.5812	MgAl8Zn1		80-180		0,05-0,12	0,08-0,25
R8650		Technograph15		80-180		0,05-0,12	0,08-0,25
W-Cu80/20		W93NiFe (DENAL)		80-180		0,05-0,12	0,08-0,25
TZC, TZM		MHC, ODS		80-180		0,05-0,12	0,08-0,25
RNi8	1.3926	RNi12		30-80		0,01-0,04	0,02-0,07
Ni54	1.3921	Ni49		18-75		0,01-0,04	0,02-0,07
NiCu 30 Fe		Monel 400		18-75		0,01-0,04	0,02-0,07
NiMo16Cr16Ti		Hastelloy C-276		18-40		0,01-0,04	0,02-0,07
NiCr20TiAl		Nimonic 80		18-40		0,01-0,04	0,02-0,07
NiCr19Co14Mo4Ti		Waspaloy		18-40		0,01-0,04	0,02-0,07
X12CrNiMo12	1.4980	X6NiCrTiMoVB25-15-2		15-30		0,01-0,04	0,02-0,07
NiCr23Fe, Inconel 601	2.4667	SG-NiCr19NbMoTi		15-30		0,01-0,04	0,02-0,07
Ti99,7	3.7064	Ti99,5		15-30		0,01-0,04	0,02-0,07
TiAl6V6Sn2	3.7124	TiCu2		100-150		0,01-0,04	0,02-0,07
TiAl6Sn2Zr4Mo2	3.7154	TiAl6Zr5		100-150		0,01-0,04	0,02-0,07

f: (mm/U) \cong (mm/Rev.)



 **Dümmel**
WERKZEUGFABRIK

NUTSTOSSEN



**Herstellung von Längsnuten Breite 2-20 mm
und Innensechskant**

**Broaching keyways in the range of 2-20 mm
and hexagon socket**

NUTSTOSSEN

von Längsnuten nach
DIN 138 und DIN 6885

broaching keyways according
DIN 138 und DIN 6885

Übersicht

summary



Allgemeine Beschreibung

general instructions

... 282

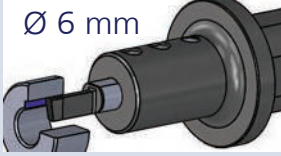
 Ø 6 mm	Nutstossen ab D min. 6 mm	broaching keyways starting D min. 6 mm	Maße dimensions	Seite page
	Klemmhalter Typ NHU und Schneideinsatz Typ NPU	toolholder type NHU and insert type NPU		

Typ NHU	Klemmhalter	toolholder	D min. 6	... 283
Typ NPU	Schneideinsatz Toleranzklasse C11 / JS9 / P9 / H9	insert tolerance grade C11 / JS9 / P9 / H9	D min. 6 - 7 B = 2 - 5	... 284
Typ NPU. ...45	Schneideinsatz Fasen 45°	insert chamfering 45°	D min. 9	... 286

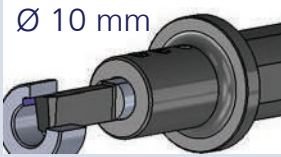
 Ø 10 mm	Nutstossen D min. 10 mm	broaching keyways D min. 10 mm	Maße dimensions	Seite page
	Klemmhalter Typ NH10 und Schneideinsatz Typ NP10	toolholder type NH10 and insert type NP10		

Typ NH10	Klemmhalter	toolholder	D min. 10	... 287
Typ NP10	Schneideinsatz Toleranzklasse C11 / JS9 / P9 / H9	insert tolerance grade C11 / JS9 / P9 / H9	D min. 10 B = 3 - 6	... 288

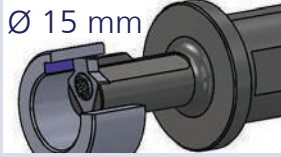
 Ø 15 mm	Nutstossen D min. 15 mm	broaching keyways D min. 15 mm	Maße dimensions	Seite page
	Klemmhalter Typ NHV.15 und Schneideinsatz Typ NV15	toolholder type NHV.15 and insert type NV15		

Typ NHV.15.IK25	Klemmhalter mit Innenkühlung	toolholder with internal cooling	D min. 15	... 290
Typ NHV.15	Klemmhalter für angetriebene Stosswerkzeuge	toolholder for driven slotting tool	D min. 15	... 291
Typ NV15	Schneideinsatz Nuttiefe bis 3.3 mm Toleranzklasse C11 / JS9 / P9 / inch	insert depth of groove up to 3.3 tolerance grade C11 / JS9 / P9 / inch	D min. 15 B = 4 - 6	... 292
Typ NV15. ...45	Schneideinsatz Fasen 45°	insert chamfering 45°	D min. 15 B = 5 - 8	... 298

NUTSTOSEN

von Längsnuten nach
DIN 138 und DIN 6885

broaching keyways according
DIN 138 und DIN 6885

Übersicht

summary

 <p>Ø 22 mm</p>	<p>Nutstossen ab D min. 22 mm</p> <p>Klemmhalter Typ NHV und Schneideinsatz Typ NPV</p>	<p>broaching keyways starting D min. 22 mm</p> <p>toolholder type NHV and insert type NPV</p>	<p>Maße dimensions</p>	<p>Seite page</p>
<p>Typ NHV.22 Typ NHV.30 Typ NHV.38 Typ NHV.45</p>	<p>Klemmhalter</p>	<p>toolholder</p>	<p>D min. 22 D min. 30 D min. 38 D min. 45</p>	<p>... 293</p>
<p>Typ NHV.22 Typ NHV.30</p>	<p>Klemmhalter für angetriebene Stosswerkzeuge</p>	<p>toolholder for driven slotting tool</p>	<p>D min. 22 D min. 30</p>	<p>... 294</p>
<p>Typ NPV</p>	<p>Schneideinsatz Nuttiefe bis 10 mm Toleranzklasse C11 / JS9 / P9 / H9 / inch</p>	<p>insert depth of groove up to 10 tolerance grade C11 / JS9 / P9 / H9 / inch</p>	<p>D min. 22 - 45 B = 5 - 20</p>	<p>... 295</p>
<p>Typ NPV. ...45</p>	<p>Schneideinsatz Fasen 45°</p>	<p>insert chamfering 45°</p>	<p>D min. 22 / 38 B = 6 - 12</p>	<p>... 298</p>
 <p>SW 2.5-16</p>	<p>Nutstossen Schlüsselweite 2.5 - 16</p> <p>Schneideinsatz Typ NPU.SW / NP10.SW</p>	<p>broaching keyways wrench size 2.5 - 16</p> <p>insert type NPU.SW / NP10.SW</p>	<p>Maße dimensions</p>	<p>Seite page</p>
<p>Typ NPU.SW</p>	<p>Schneideinsatz für Innensechskant</p>	<p>insert for hexagon socket</p>	<p>SW 2.5 - 8</p>	<p>... 299</p>
<p>Typ NP10.SW</p>	<p>Schneideinsatz für Innensechskant</p>	<p>insert for hexagon socket</p>	<p>SW 10 - 16</p>	<p>... 300</p>



NUTSTOSSEN

von Längsnuten nach
DIN 138 und DIN 6885

broaching keyways according
DIN 138 und DIN 6885

Übersicht

summary



Sets Nutstossen

sets broaching keyways

Maße dimensions

Seite page

Halter und Schneiden

toolholder and inserts

SET - NPU

Auswahl
Toleranzklasse JS9

selection
tolerance grade JS9

D min. 6
B = 2 / 3 / 4

... 301

SET - NP10

Auswahl
Toleranzklasse JS9

selection
tolerance grade JS9

D min. 10
B = 4 / 5

... 301

SET - NPV

Auswahl
Toleranzklasse JS9

selection
tolerance grade JS9

D min. 22 / 30
B = 5.01 / 6.01
/ 8.01

... 302

Technische Hinweise

Technical Instructions

Seite page

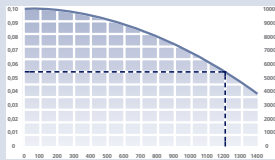

Grundsätzliche Informationen zum
Nutstossen

Basic informations about
broaching keyways

... 303

Hartmetallsorten und Beschichtungen

carbide grades and coatings

... 305

Schnittdaten

cutting data

... 307

NUTSTOSEN

von Längsnuten nach
DIN 138 und DIN 6885

broaching keyways according
DIN 138 und DIN 6885

Allgemeine Beschreibung

Stossen von Innennuten
auf CNC-Maschinen

general instructions,
broaching keyways
on CNC machines

Komplettbearbeitung auf CNC-Drehmaschinen
und Fräszentren ohne Umspannen.
Einfach und wirtschaftlich.

Complete machining on CNC turning- and milling centres
in one clamping. Simple and efficient.



NUTSTOSEN

von Längsnuten nach
DIN 138 und DIN 6885

broaching keyways according
DIN 138 und DIN 6885

Typ NHU

Klemmhalter

D min. 6 mm

toolholder

D min. 6 mm

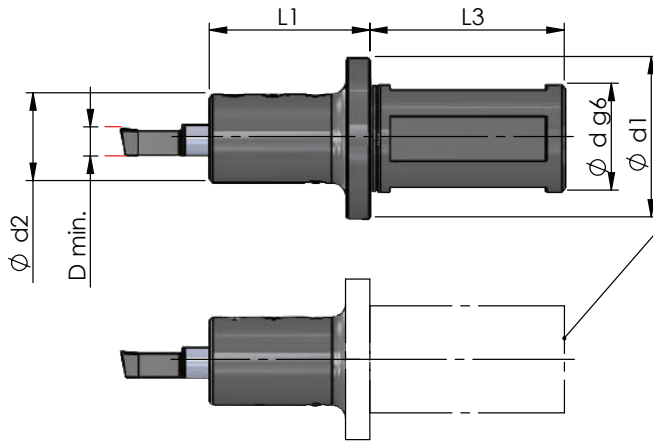

Aufnahme nach Herstellerangaben
clamping part according to
manufacturer's specification

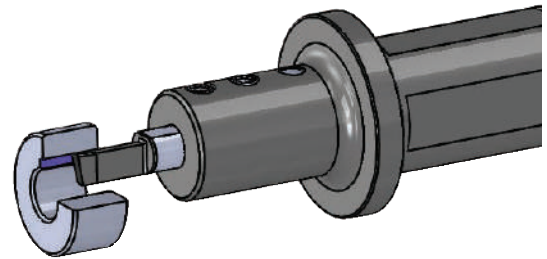

Abmessungen in mm

dimensions in mm



Bestellnummer part number	D min.	Ø d g6 x L3 Aufnahme clamping part	Ø d (inch)	L1	Ø d1	Ø d2		Spannschraube screw	Schrauben- schlüssel wrench	Anzugs- drehmoment torque	für Schneid- platte for insert
NHU.0020.1	6	Ø20 x 40		33	33	18					
NHU.0022.1	6	Ø22 x 40		33	33	18					
NHU.0025.1	6	Ø25 x 40		33	33	18		110.645	111.645	1.5 Nm	NPU,...
NHU.00254.1	6	Ø25.4 x 40	1"	33	33	18					
NHU.0032.1	6	Ø32 x 40		33	40	20		110.650	111.645	1.5 Nm	
Bestellnummer part number	D min.	Aufnahme nach Herstellerangabe clamping part acc. to manufac. specification		L1		Ø d2	für Nutstoss- geräte for broaching device	Spannschraube screw	Schrauben- schlüssel wrench	Anzugs- drehmoment torque	für Schneid- platte for insert
NHU.0012.1	6	Ø12 x 25		32		20	Schwarzer 1				
NHU.0015.1	6	Ø15 x 33		37		18	Schwarzer 2 in 1				
NHU.0016.1	6	Ø16 x 30		33		18	EWS Slot + Benz LinA				
NHU.MP16.1	6	Ø16 x 34		33		18	Mario Pinto Stoßeinheit	110.645	111.645	1.5 Nm	NPU,...
NHU.MT16.1	6	Ø16 x 25		33		18	MT Marchetti				
NHU.WT16.1	6	Ø16 x 6		36		18	WTO Stoßeinheit				

Bestellbeispiel:
NHU.0020.1

order-example:
NHU.0020.1

NUTSTOSSEN

von Längsnuten nach
DIN 138 und DIN 6885

broaching keyways according
DIN 138 und DIN 6885

Typ NPU

Schneideinsatz

D min. 6 - 7 mm
Toleranzklasse C11 / JS9 / P9 / H9

insert

D min. 6 - 7 mm
tolerance grade C11 / JS9 / P9 / H9

NPU.0... ..

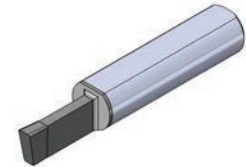
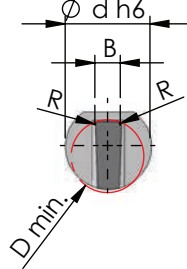
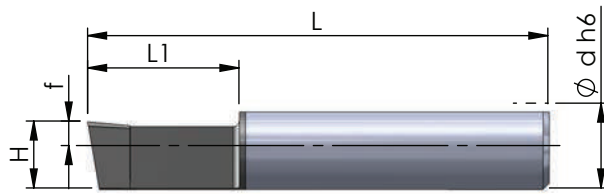

NPU.0298.01.2 / NPU.0300.01.2

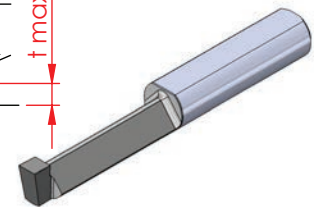
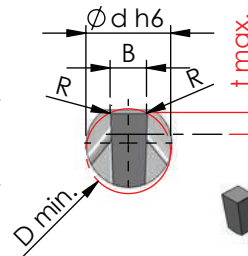
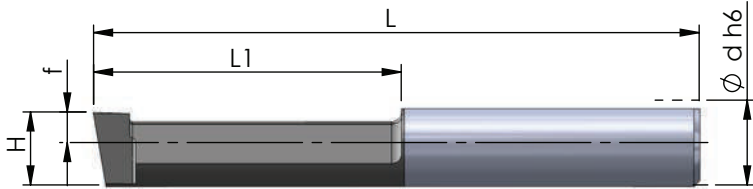

Abmessungen in mm

dimensions in mm

Bestellnummer part number	D min.	B	R	H +0.05	f	L	L1	Ø d h6	t max.	Schneideinsatz nach DIN	insert according DIN	K10F	AL41F	P18C	für Klemmhalter for toolholder type
NPU.0210.03.1	6	2.1	0.35	5.5	2.0	38	12.5	7	-			●			NHU...
NPU.0310.03.1	7	3.1	0.35	6.2	2.7	38	12.5	7	-	C11		●			
NPU.0310.05.1	7	3.1	0.5	6.2	2.7	38	12.5	7	-	DIN 138		●			
NPU.0410.05.1	7	4.1	0.5	6.2	2.7	40	15	7	-	Standard		●			
NPU.0410.05.2	7	4.1	0.5	6.2	2.7	50	25	7	-			●			
NPU.0200.01.1	6	2.00	0.1	5.5	2.0	38	12.5	7	-			●			
NPU.0300.01.1	7	3.00	0.1	6.2	2.7	38	12.5	7	-			●			
NPU.0300.01.2	7	3.00	0.1	6.0	2.5	50	25	7	1.8	JS9		●			
NPU.0400.01.1	7	4.00	0.1	6.2	2.7	40	15	7	-	DIN 6885		●			
NPU.0400.02.1	7	4.00	0.2	6.2	2.7	40	15	7	-	leichter Sitz slightly fit		●			
NPU.0400.02.2	7	4.00	0.2	6.2	2.7	50	25	7	-			●			
NPU.0500.02.2	7	5.00	0.2	5.8	2.3	50	25	7	-			●			
↳ ...															

Weitere HM Sorten können Sie in der Sortenübersicht im Kapitel "Technische Hinweise" und der Preisliste finden.

Bestellbeispiel:
für Sorte AL41F:
NPU.0210.03.1/AL41F

More carbide grades you can find in the grades summary in the chapter "technical instructions" and in the price list.

order-example:
grade AL41F:
NPU.0210.03.1/AL41F



NUTSTOSEN

von Längsnuten nach
DIN 138 und DIN 6885

broaching keyways according
DIN 138 und DIN 6885

Typ NPU

Schneideinsatz

D min. 6 - 7 mm
Toleranzklasse C11 / JS9 / P9 / H9

insert

D min. 6 - 7 mm
tolerance grade C11 / JS9 / P9 / H9

NPU.0... ..

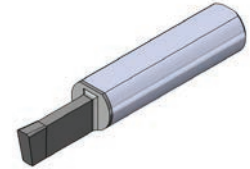
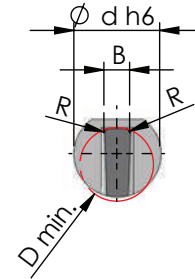
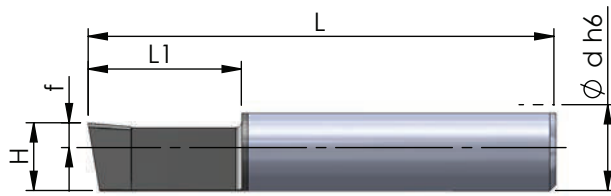

NPU.0298.01.2 / NPU.0300.01.2

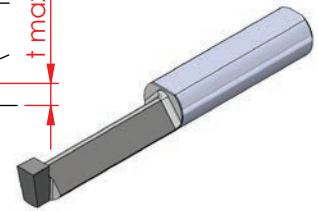
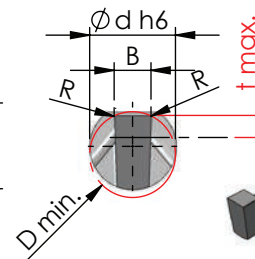
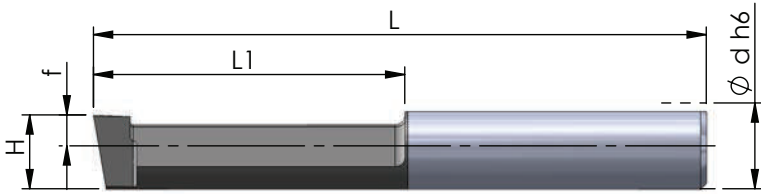

Abmessungen in mm

dimensions in mm



Bestellnummer part number	D min.	B	R	H +0.05	f	L	L1	Ø d h6	t max.	Schneideinsatz nach DIN	insert according DIN	K10F	AL41F	P18C	für Klemhalter for toolholder type
NPU.0198.01.1	6	1.98	0.1	5.5	2.0	38	12.5	7	-			●			NHU,...
NPU.0298.01.1	7	2.98	0.1	6.2	2.7	38	12.5	7	-	p9		●			
NPU.0298.01.2	7	2.98	0.1	6.0	2.5	50	25	7	1.8	DIN 6885		●			
NPU.0398.01.1	7	3.98	0.1	6.2	2.7	40	15	7	-	fester Sitz		●			
NPU.0398.02.2	7	3.98	0.2	6.2	2.7	50	25	7	-	strong fit		●			
NPU.0498.02.2	7	4.98	0.2	5.8	2.3	50	25	7	-			●			
NPU.020H.01.1	6	2.02	0.1	5.5	2.0	38	12.5	7	-			●			
NPU.030H.01.1	7	3.02	0.1	6.2	2.7	38	12.5	7	-			●			
NPU.040H.01.1	7	4.02	0.1	6.2	2.7	40	15	7	-	H9		●			
NPU.040H.02.2	7	4.02	0.2	6.2	2.7	50	25	7	-	DIN 6885		●			
NPU.050H.02.2	7	5.02	0.2	5.8	2.3	50	25	7	-			●			

Weitere HM Sorten können Sie in der Sortenübersicht im Kapitel "Technische Hinweise" und der Preisliste finden.

Bestellbeispiel:
für Sorte AL41F:
NPU.0198.01.1/AL41F

More carbide grades you can find in the grades summary in the chapter "technical instructions" and in the price list.

order-example:
grade AL41F:
NPU.0198.01.1/AL41F

NUTSTOSEN

von Längsnuten nach
DIN 138 und DIN 6885

broaching keyways according
DIN 138 und DIN 6885

Typ NPU. ... 45

Schneideinsatz
Fasen 45°

D min. 9 mm

insert
chamfering 45°

D min. 9 mm

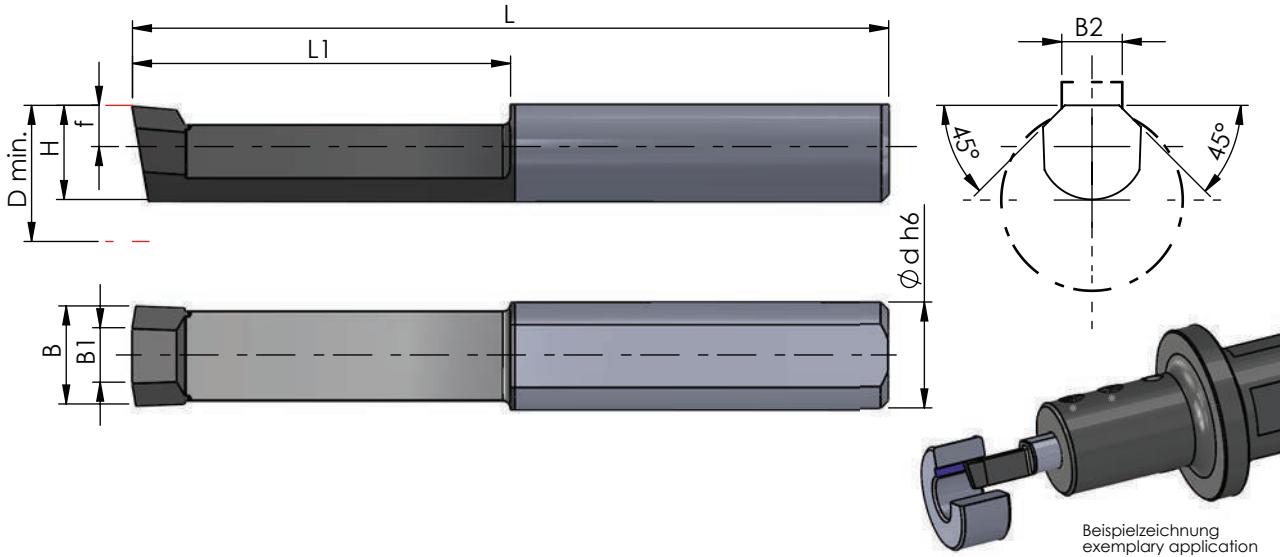

Abmessungen in mm

dimensions in mm

Bestellnummer part number	D min.	B	B1	B2 Nutenbreite width of groove	H +0.05	f	L	L1	Ø d h6	Klemmhalter for toolholder type		
										K10F	AL41F	P18C
NPU.4545.1	9	6.5	3.6	4 - 5	6.2	2.7	50	25	7	●		NHU...



Weitere HM Sorten können Sie in der Sortenübersicht im Kapitel "Technische Hinweise" und der Preisliste finden.

Bestellbeispiel:
für Sorte AL41F:
NPU.4545.1/AL41F

More carbide grades you can find in the grades summary in the chapter "technical instructions" and in the price list.

order-example:
grade AL41F:
NPU.4545.1/AL41F

NUTSTOSSEN

von Längsnuten nach
DIN 138 und DIN 6885

broaching keyways according
DIN 138 und DIN 6885

Typ NH10

Klemmhalter

D min. 10 mm

toolholder

D min. 10 mm

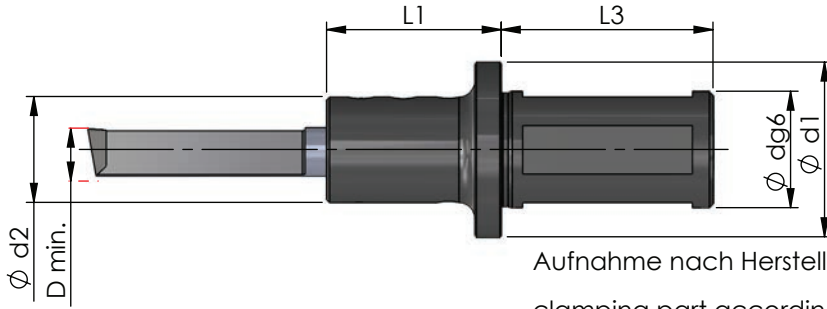

Aufnahme nach Herstellerangaben

clamping part according to
manufacture's specification

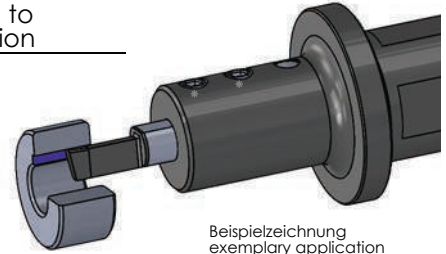
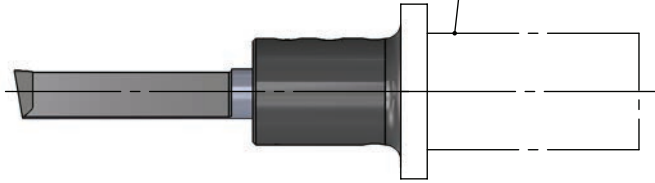

Beispielzeichnung
exemplary application

Abmessungen in mm

dimensions in mm



Bestellnummer part number	D min.	Ø d g6 x L3 Aufnahme clamping part	L1	Ø d1	Ø d2		Spannschraube screw	Schraubenschlüssel wrench	Anzugs- drehmoment torque	für Schneidplatte for insert
NH10.0020.1	10	Ø20 x 40	33	33	20					
NH10.0022.1	10	Ø22 x 40	33	33	20					
NH10.0025.1	10	Ø25 x 40	33	33	20		110.660	111.687	2.5 Nm	NP10,...
NH10.0032.1	10	Ø32 x 40	33	40	20					
Bestellnummer part number	D min.	Aufnahme nach Herstellerangabe clamping part acc. to manufac. specification			Ø d2	für Nutstossergeräte for broaching device	Spannschraube screw	Schraubenschlüssel wrench	Anzugs- drehmoment torque	für Schneidplatte for insert
NH10.0012.1	10	Ø12 x 25			32	Schwarzer 1				
NH10.0015.1	10	Ø15 x 33			37	Schwarzer 2 in 1				
NH10.0016.1	10	Ø16 x 30			33	EWS Slot + Benz LinA				
NH10.MP16.1	10	Ø16 x 34			33	Mario Pinto Stoßeinheit	110.660	111.687	2.5 Nm	NP10,...
NH10.MT16.1	10	Ø16 x 25			33	MT Marchetti				
NH10.WT16.1	10	Ø16 x 6			36	WTO Stoßeinheit				

Bestellbeispiel:
NH10.0020.1

order-example:
NH10.0020.1

NUTSTOSEN

von Längsnuten nach
DIN 138 und DIN 6885

broaching keyways according
DIN 138 und DIN 6885

Typ NP10

Schneideinsatz

D min. 10 mm
Toleranzklasse C11 / JS9 / P9 / H9

insert

D min. 10 mm
tolerance grade C11 / JS9 / P9 / H9

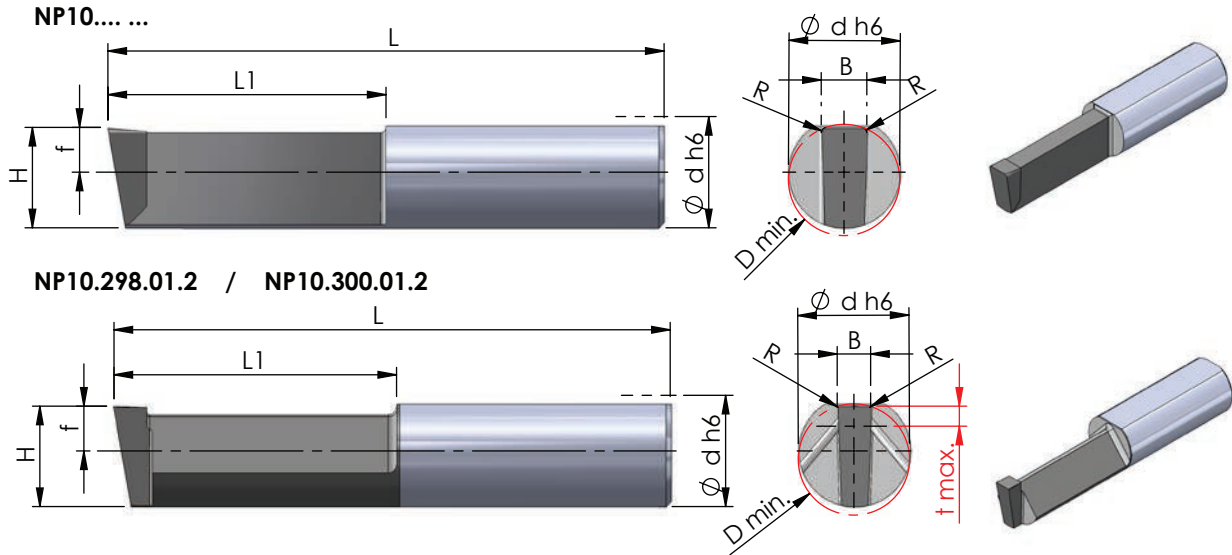

Abmessungen in mm

dimensions in mm

Bestellnummer part number	D min.	B	R	H +0.05	f	L	L1	Ø d h6	t max.	Schneideinsatz nach DIN	insert according DIN	K10F	AL41F	P18C	für Klemhalter for toolholder type
NP10.410.05.2	10	4.1	0.5	9	4	50	25	10	-	C11 DIN 138	insert	●	●	NH10...	
NP10.410.05.3	10	4.1	0.5	9	4	66	41	10	-						
NP10.510.05.2	10	5.1	0.5	9	4	50	25	10	-	Standard	●	●			
NP10.510.05.3	10	5.1	0.5	9	4	66	41	10	-						
NP10.300.01.2	10	3.0	0.1	9	4	50	25	10	1.8	JS9 DIN 6885	●	●			
NP10.400.02.2	10	4.0	0.2	9	4	50	25	10	-						
NP10.400.02.3	10	4.0	0.2	9	4	66	41	10	-	leichter Sitz slightly fit	●	●			
NP10.500.02.2	10	5.0	0.2	9	4	50	25	10	-						
NP10.500.02.3	10	5.0	0.2	9	4	66	41	10	-						
NP10.600.02.3	10	6.0	0.2	8.5	3.5	66	41	10	-		●	●			
↳ ...															

Weitere HM Sorten können Sie in der Sortenübersicht im Kapitel "Technische Hinweise" und der Preisliste finden.

Bestellbeispiel:
für Sorte AL41F:
NP10.410.05.2/AL41F

More carbide grades you can find in the grades summary in the chapter "technical instructions" and in the price list.

order-example:
grade AL41F:
NP10.410.05.2/AL41F

NUTSTOSSEN

von Längsnuten nach
DIN 138 und DIN 6885

broaching keyways according
DIN 138 und DIN 6885

Typ NP10

Schneideinsatz

D min. 10 mm
Toleranzklasse C11 / JS9 / P9 / H9

insert

D min. 10 mm
tolerance grade C11 / JS9 / P9 / H9

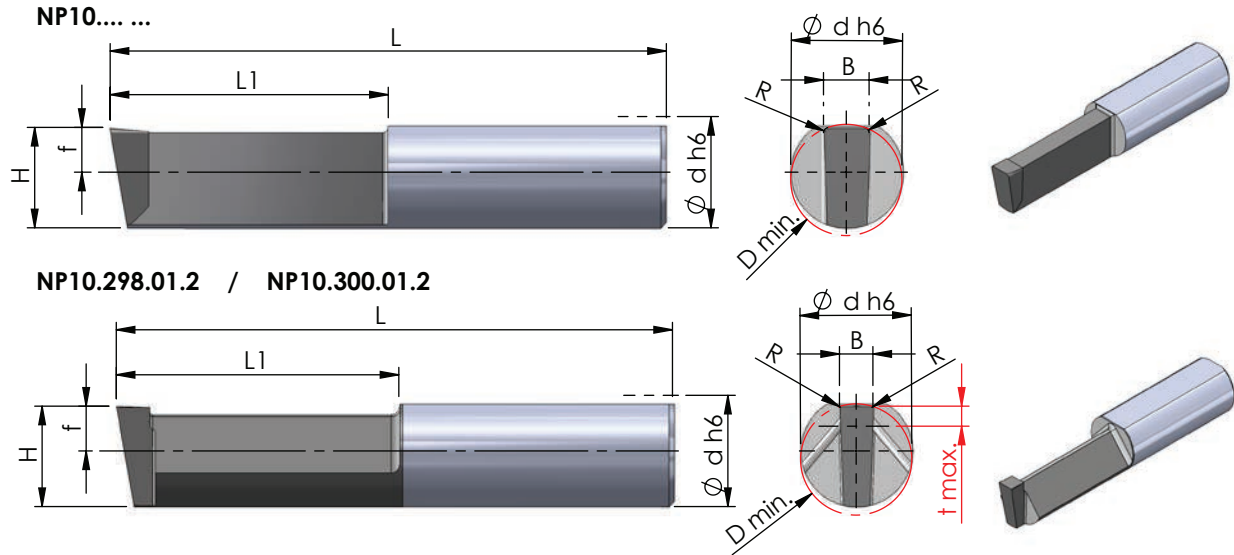

Abmessungen in mm

dimensions in mm



Bestellnummer part number	D min.	B	R	H +0.05	f	L	L1	Ø d h6	t max.	Schneideinsatz nach DIN	insert according DIN	K10F	AL41F	P18C	für Klemhalter for toolholder type
NP10.298.01.2	10	2.98	0.1	9	4	50	25	10	1.8						NH10...
NP10.398.02.2	10	3.98	0.2	9	4	50	25	10	-	p9					
NP10.398.02.3	10	3.98	0.2	9	4	66	41	10	-	DIN 6885					
NP10.498.02.2	10	4.98	0.2	9	4	50	25	10	-	fester Sitz					
NP10.498.02.3	10	4.98	0.2	9	4	66	41	10	-	strong fit					
NP10.598.02.3	10	5.98	0.2	8.5	3.5	66	41	10	-						
NP10.040H.02.2	10	4.02	0.2	9	4	50	25	10	-						
NP10.040H.02.3	10	4.02	0.2	9	4	66	41	10	-						
NP10.050H.02.2	10	5.02	0.2	9	4	50	25	10	-						
NP10.050H.02.3	10	5.02	0.2	9	4	66	41	10	-	H9					
NP10.060H.02.3	10	6.05	0.2	8.5	3.5	66	41	10	-	DIN 6885					

Weitere HM Sorten können Sie in der Sortenübersicht im Kapitel "Technische Hinweise" und der Preisliste finden.

Bestellbeispiel:
für Sorte AL41F:
NP10.298.01.2/AL41F

More carbide grades you can find in the grades summary in the chapter "technical instructions" and in the price list.

order-example:
grade AL41F:
NP10.298.01.2/AL41F

NUTSTOSEN

von Längsnuten nach
DIN 138 und DIN 6885

broaching keyways according
DIN 138 und DIN 6885

Typ NHV.15.IK25

Klemmhalter
mit Innenkühlung

toolholder
with internal cooling

D min. 15 mm

D min. 15 mm

innere Kühlmittelzufuhr
through coolant

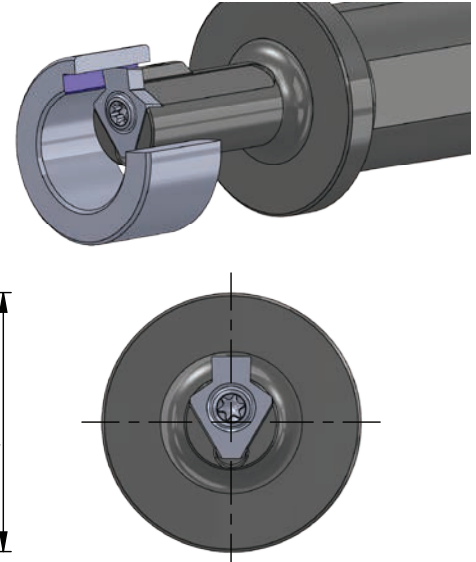
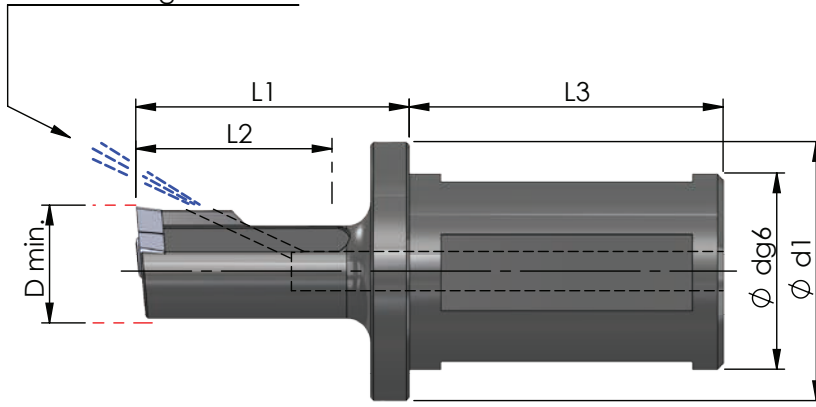

Abmessungen in mm

dimensions in mm

Bestellnummer part number	D min.	Ø d g6 x L3 Aufnahme clamping part	L1	L2	Ø d1	Spannschraube screw	Schraubenschlüssel wrench	Anzugs- drehmoment torque	für Schneidplatte for insert
NHV.15.IK25.1	15	Ø25 x 40	35	25	33	M4-NH15	Torx TR15	4.0 Nm	NV15...
NHV.15.IK25.2	15	Ø25 x 40	50	40	33				
NHV.15.IK25.3	15	Ø25 x 40	70	60	33				



Bestellbeispiel:
NHV.15.IK25.1

order-example:
NHV.15.IK25.1

NUTSTOSEN

von Längsnuten nach
DIN 138 und DIN 6885

broaching keyways according
DIN 138 und DIN 6885

Typ NHV.15

Klemmhalter
für angetriebene Stosswerkzeuge

D min. 15 mm

toolholder
for driven slotting tool

D min. 15 mm

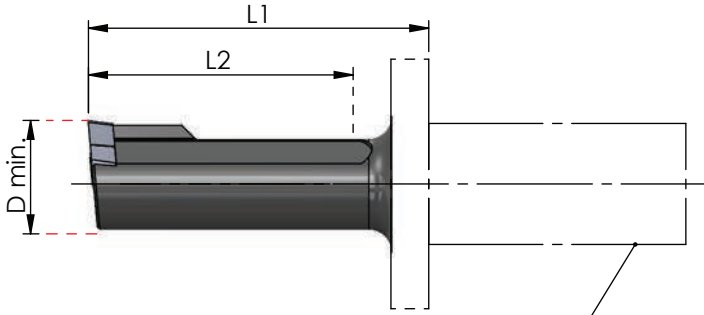

Aufnahme nach Herstellerangaben
clamping part according to
manufacturer's specification

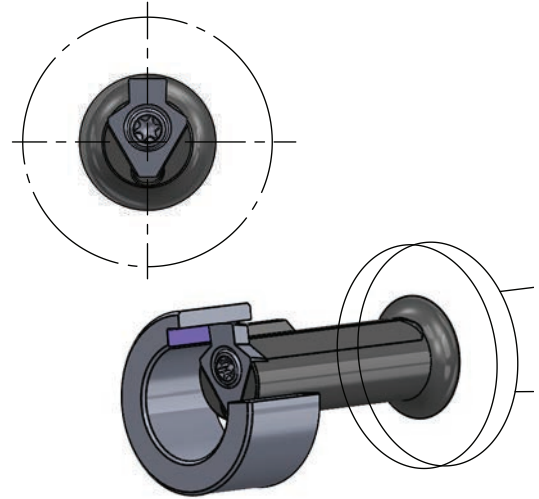

Abmessungen in mm

dimensions in mm



Bestellnummer part number	D min.	Aufnahme nach Herstellerangabe clamping part acc. to manufac. specification	L1	L2	für Nutstossergeräte for broaching device	Spannschraube screw	Schraubenschlüssel wrench	Anzugs- drehmoment torque	für Schneidplatte for insert
NHV.15.0012.1	15	Ø12 x 25	40	36	Schwarzer 1	M4-NH15	Torx TR15	4 Nm	NV15...
NHV.15.0015.1	15	Ø15 x 33	45	36	Schwarzer 2 in 1				
NHV.15.0015.2	15	Ø15 x 30	58	42	Schwarzer 2 in 1				
NHV.15.0016.1	15	Ø16 x 30	46	36	EWS Slot + Benz LinA				
NHV.15.MP16.1	15	Ø16 x 34	45	35	Mario Pinto Stoßeinheit				
NHV.15.MP16.2	15	Ø16 x 34	75	65	Mario Pinto Stoßeinheit				
NHV.15.MT16.1	15	Ø16 x 25	50	40	MT Marchetti				
NHV.15.WT16.1	15	Ø16 x 6	49	35	WTO Stoßeinheit				

Bestellbeispiel:
NHV.15.0012.1

order-example:
NHV.15.0012.1

NUTSTOSSEN

von Längsnuten nach
DIN 138 und DIN 6885

broaching keyways according
DIN 138 und DIN 6885

Typ NV15

Schneideinsatz

insert

D min. 15 mm
Nuttiefe bis 3.3
Toleranzklasse C11 / JS9 / P9 / inch

D min. 15 mm
depth of groove up to 3.3
tolerance grade C11 / JS9 / P9 / inch

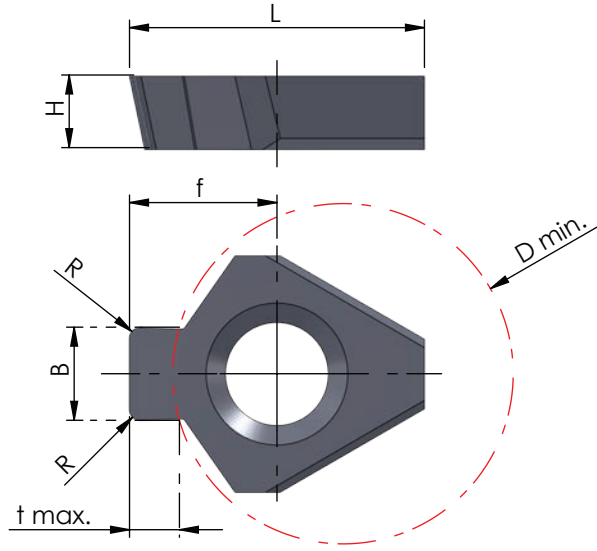

Beispielzeichnung
exemplary application

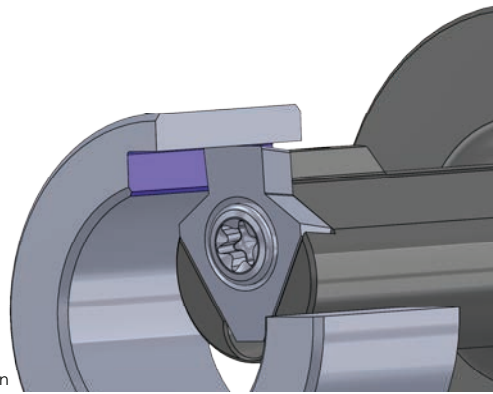

Abmessungen in mm

dimensions in mm

Bestellnummer part number	D min.	B	B (inch)	R	f	L	t max.	H	Schneideinsatz nach DIN	insert according DIN	für Klemhalter for toolholder type						
											K10F	AL41F	P18C				
NV15.0410.050	15	4.10		0.50	6.5	13	2.2	3.2	C11 DIN 138 Standard	●	●	●	NHV.15...				
NV15.0510.050	15	5.10		0.50	6.5	13	2.5	3.2									
NV15.0612.085	15	6.12		0.85	6.5	13	2.6	3.2									
NV15.0401.02	15	4.01		0.20	6.5	13	2.3	3.2						JS9 DIN 6885 leichter Sitz slightly fit	●	●	●
NV15.0501.02	15	5.01		0.20	6.5	13	2.8	3.2									
NV15.0601.02	15	6.01		0.20	6.5	13	3.3	3.2									
NV15.0398.02	15	3.98		0.20	6.5	13	2.3	3.2						P9 DIN 6885 fester Sitz strong fit	●	●	●
NV15.0498.02	15	4.98		0.20	6.5	13	2.8	3.2									
NV15.0598.02	15	5.98		0.20	6.5	13	3.3	3.2									
NV15.U0478.02	15	4.78	0.189"	0.20	6.5	13	2.8	3.2	inch	●	●	●					



Weitere HM Sorten können Sie in der Sortenübersicht im Kapitel "Technische Hinweise" und der Preisliste finden.

Bestellbeispiel:
für Sorte AL41F:
NV15.0410.050/AL41F

More carbide grades you can find in the grades summary in the chapter "technical instructions" and in the price list.

order-example:
grade AL41F:
NV15.0410.050/AL41F

NUTSTOSEN

von Längsnuten nach
DIN 138 und DIN 6885

broaching keyways according
DIN 138 und DIN 6885

Typ NHV

Klemmhalter

D min. 22 / 30 / 38 / 45 mm

toolholder

D min. 22 / 30 / 38 / 45 mm

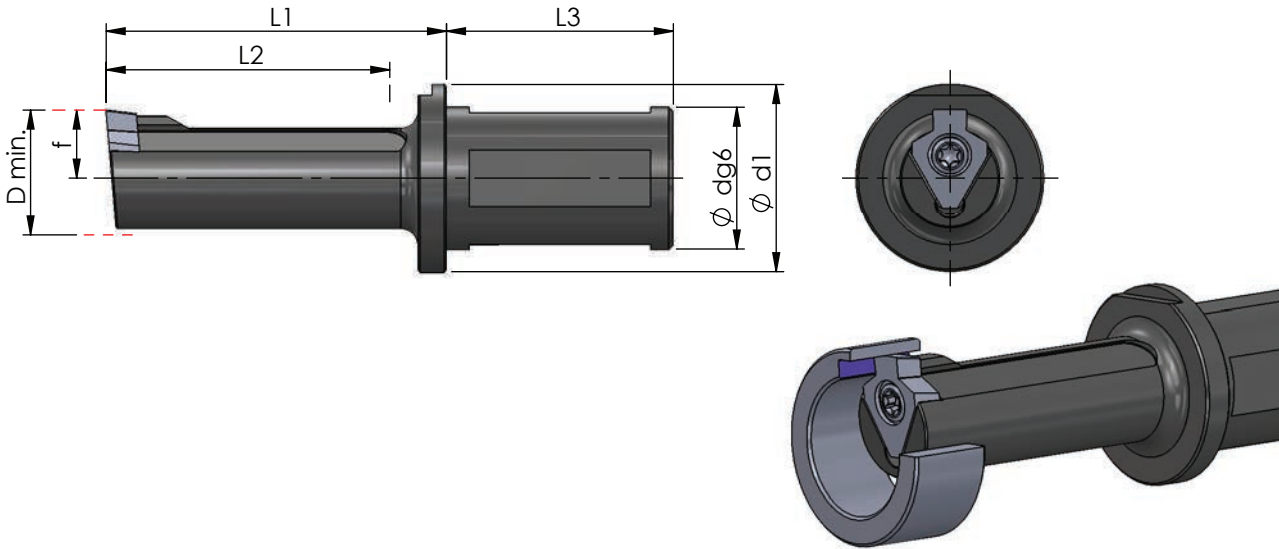

Abmessungen in mm

dimensions in mm



Bestellnummer part number	D min.	Ø d g6 x L3 Aufnahme clamping part	L1	L2	f	Ø d1	Spannschraube screw	Schraubenschlüssel wrench	Anzugs- drehmoment torque	für Schneidplatte for insert
NHV.22.0025.1	22	Ø25 x 40	60	50	12	33	85.818	Torx TX20	6.0 Nm	NPV...
NHV.22.0025.2	22	Ø25 x 40	85	75	12	33				
NHV.30.0032.1	30	Ø32 x 40	60	50	16.5	45				
NHV.30.0032.2	30	Ø32 x 40	85	75	16.5	45				
NHV.30.0032.3	30	Ø32 x 40	115	105	16.5	45				
NHV.38.0032.1	38	Ø32 x 40	60	50	22	45				
NHV.38.0032.2	38	Ø32 x 40	85	75	22	45				
NHV.38.0032.3	38	Ø32 x 40	115	105	22	45				
NHV.45.0040.1	45	Ø40 x 60	60	50	24	55				
NHV.45.0040.3	45	Ø40 x 60	115	105	24	55				
NHV.45.0040.4	45	Ø40 x 60	165	155	24	55				

Bestellbeispiel:
NHV.22.0025.1

order-example:
NHV.22.0025.1

NUTSTOSEN

von Längsnuten nach
DIN 138 und DIN 6885

broaching keyways according
DIN 138 und DIN 6885

Typ NHV

Klemmhalter
für angetriebene Stosswerkzeuge

D min. 22 / 30 mm

toolholder
for driven slotting tool

D min. 22 / 30 mm

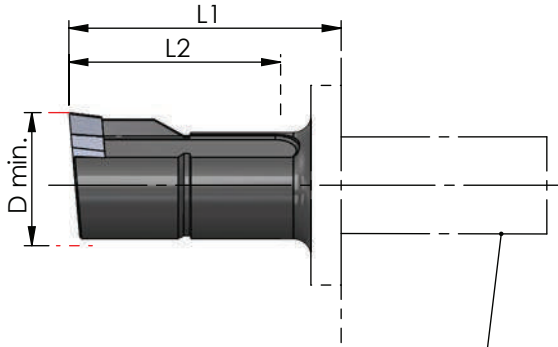

Aufnahme nach Herstellerangaben
clamping part according to
manufacturer's specification

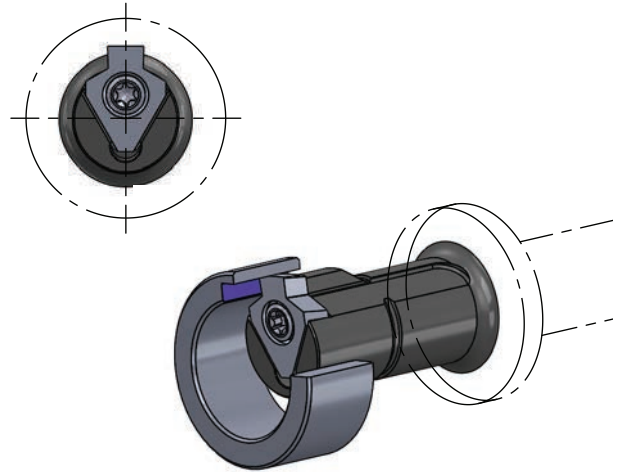

Abmessungen in mm

dimensions in mm

Bestellnummer part number	D min.	Aufnahme nach Herstellerangabe clamping part acc. to manufac. specification	L2	für Nutstosseräte for broaching device	Spannschraube screw	Schraubenschlüssel wrench	Anzugs- drehmoment torque	für Schneidplatte for insert
NHV.22.0012.1	22	Ø12 x 25	40	Schwarzer 1				
NHV.22.0015.1	22	Ø15 x 33	37	Schwarzer 2 in 1				
NHV.22.0015.2	22	Ø15 x 30	50	Schwarzer 2 in 1				
NHV.22.0016.1	22	Ø16 x 30	45	EWS Slot + Benz LinA				
NHV.22.0016.2	22	Ø16 x 30	65	EWS Slot + Benz LinA				
NHV.22.MP16.1	22	Ø16 x 34	45	Mario Pinto Stoßeinheit	85.818	Torx TX20	6 Nm	NPV....
NHV.22.MP16.2	22	Ø16 x 34	75	Mario Pinto Stoßeinheit				
NHV.22.MT16.1	22	Ø16 x 25	58	MT Marchetti				
NHV.22.WT16.1	22	Ø16 x 6	49	WTO Stoßeinheit				
NHV.30.0012.1	30	Ø12 x 25	40	Schwarzer 1				



Bestellbeispiel:
NHV.22.0012.1

order-example:
NHV.22.0012.1

NUTSTOSEN

von Längsnuten nach
DIN 138 und DIN 6885

broaching keyways according
DIN 138 und DIN 6885

Typ NPV

Schneideinsatz
Nuttiefe bis 10 mm,
Toleranzklassen C11 / JS9 / P9 / H9 / inch

D min. 22 - 45 mm
B = 5 - 20

insert
depth of groove up to 10 mm,
tolerance grade C11 / JS9 / P9 / H9 / inch

D min. 22 - 45 mm
B = 5 - 20

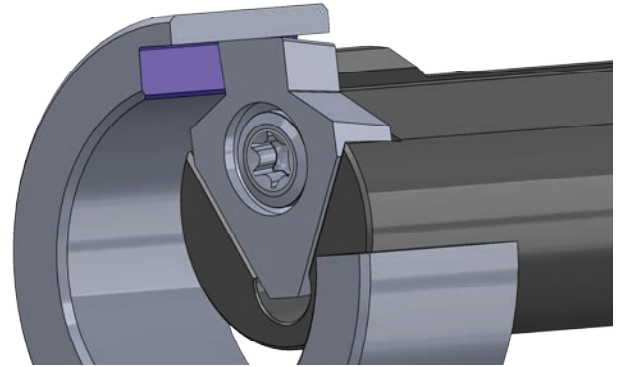
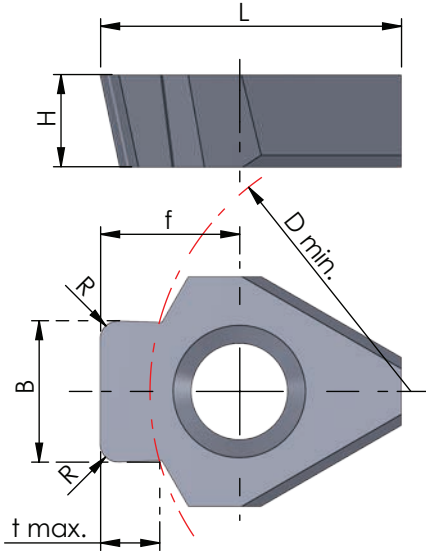

Abmessungen in mm

dimensions in mm



Bestellnummer part number	D min.	B	B (inch)	R	f	L	t max.	H	Schneideinsatz nach DIN	insert according DIN				für Klemmhalter for toolholder type
											K10F	AL41F	P18C	
NPV.0612.085	22	6.12		0.85	8	17.3	2.6	5.3	C11		●			NHV.22...
NPV.0713.085	22	7.13		0.85	8	17.3	3.3	5.3	DIN 138		●			NHV.22...
NPV.0813.105	30	8.13		1.05	8	17.3	3.4	5.3	Standard		●			NHV.30... (NHV.22)
NPV.0501.02	22	5.01		0.2	8	17.3	2.7	5.3	JS9		●			NHV.22...
NPV.0601.02	22	6.01		0.2	8	17.3	3.4	5.3	DIN 6885		●			NHV.22...
NPV.0801.02	30	8.01		0.2	8	17.3	4.1	5.3	leichter Sitz slightly fit		●			NHV.30... (NHV.22)
NPV.0498.02	22	4.98		0.2	8	17.3	2.7	5.3	P9		●			NHV.22...
NPV.0598.02	22	5.98		0.2	8	17.3	3.4	5.3	DIN 6885		●			NHV.22...
NPV.0798.02	30	7.98		0.2	8	17.3	4.1	5.3	fester Sitz strong fit		●			NHV.30... (NHV.22)
NPV.050H.02	22	5.02		0.2	8	17.3	2.7	5.3	H9		●			NHV.22...
NPV.060H.02	22	6.02		0.2	8	17.3	3.4	5.3	DIN 6885		●			NHV.22...
NPV.080H.02	30	8.02		0.2	8	17.3	4.1	5.3			●			NHV.30... (NHV.22)
neu NPV.U0638.02	22	6.38	0.251"	0.2	8	17.3	3.4	5.3	inch		●			NHV.22...
neu NPV.U0797.02	22	7.97	0.314"	0.2	8	17.3	4.1	5.3			●			NHV.22...
↳ ...														

Klemmhalter in Klammer sind nicht optimal in der Unterstützung. Schnittwerte reduzieren!
Weitere HM Sorten können Sie in der Sortenübersicht im Kapitel "Technische Hinweise" und der Preisliste finden.
Bestellbeispiel:
für Sorte AL41F:
NPV.0612.085/AL41F

Please note that toolholders in brackets are not the optimal choice. If using them, please reduce the cutting data!
More carbide grades you can find in the grades summary in the chapter "technical instructions" and in the price list.
order-example:
grade AL41F:
NPV.0612.085/AL41F

NUTSTOSEN

von Längsnuten nach
DIN 138 und DIN 6885

broaching keyways according
DIN 138 und DIN 6885

Typ NPV

Schneideinsatz
Nuttiefe bis 10 mm,
Toleranzklassen C11 / JS9 / P9 / H9 / inch

insert
depth of groove up to 10 mm,
tolerance grade C11 / JS9 / P9 / H9 / inch

D min. 22 - 45 mm
B = 5 - 20

D min. 22 - 45 mm
B = 5 - 20

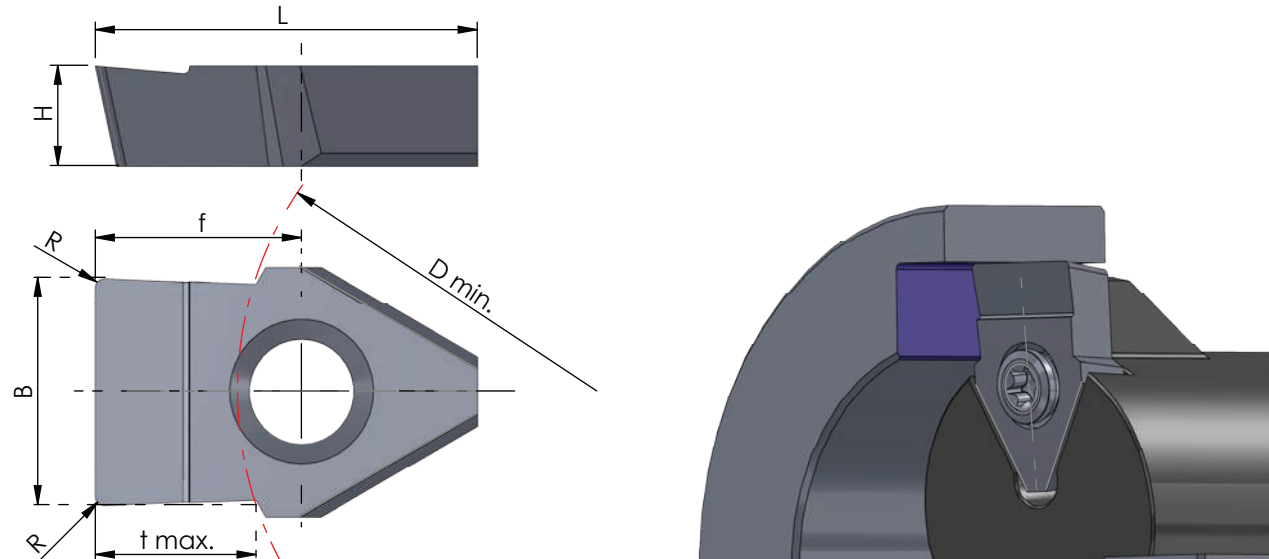

Abmessungen in mm

dimensions in mm

Bestellnummer part number	Abmessungen in mm							Schneideinsatz nach DIN	insert according DIN	K10F AL41F P18C	für Klemmhalter for toolholder type	
	D min.	B	R	f	L	t max.	H					
NPV.1001.03	38	10.01	0.3	8	17.3	4.2	5.3	JS9 DIN 6885 leichter Sitz	●	NHV.38..(NHV.30/22..)		
NPV.1202.03	38	12.02	0.3	10.9	20.1	5.7	5.3			NHV.38..(NHV.30/22..)		
NPV.1202.05	38	12.02	0.5	10.9	20.1	8.5	5.3			NHV.38..(NHV.30/22..)		
NPV.1402.03	45	14.02	0.3	10.9	20.1	7.5	6.3			slightly fit	●	NHV.45..(NHV.38/30/22..)
NPV.1602.03	45	16.02	0.3	10.9	20.1	7.5	6.3					NHV.45..(NHV.38/30/22..)
NPV.1802.05	45	18.02	0.4	10.9	20.1	9.5	6.3					NHV.45..(NHV.38/30/22..)
NPV.2002.05	45	20.02	0.5	10.9	20.1	10	6.3			●	NHV.45..(NHV.38/30/22..)	
NPV.0998.03	38	9.98	0.3	8	17.3	4.2	5.3	p9 DIN 6885 fester Sitz	●	NHV.38..(NHV.30/22..)		
NPV.1197.03	38	11.98	0.3	10.9	20.1	5.7	5.3			NHV.38..(NHV.30/22..)		
NPV.1397.03	45	13.97	0.3	10.9	20.1	7.5	6.3			strong fit	●	NHV.45..(NHV.38/30/22..)
NPV.1597.03	45	15.97	0.3	10.9	20.1	7.5	6.3					NHV.45..(NHV.38/30/22..)
NPV.1797.05	45	17.97	0.4	10.9	20.1	9.5	6.3					NHV.45..(NHV.38/30/22..)
NPV.1997.05	45	19.97	0.5	10.9	20.1	10	6.3			●	NHV.45..(NHV.38/30/22..)	

Klemmhalter in Klammer sind nicht optimal in der Unterstützung. Schnittwerte reduzieren!
Weitere HM Sorten können Sie in der Sortenübersicht im Kapitel "Technische Hinweise" und der Preisliste finden.
Bestellbeispiel:
für Sorte AL41F:
NPV.1001.03/AL41F

Please note that toolholders in brackets are not the optimal choice. If using them, please reduce the cutting data!
More carbide grades you can find in the grades summary in the chapter "technical instructions" and in the price list.
order-example:
grade AL41F:
NPV.1001.03/AL41F

NUTSTOSEN

von Längsnuten nach
DIN 138 und DIN 6885

broaching keyways according
DIN 138 und DIN 6885

Typ NPV

Schneideinsatz
Nuttiefe bis 10 mm,
Toleranzklassen C11 / JS9 / P9 / H9 / inch

D min. 22 - 45 mm
B = 5 - 20

insert
depth of groove up to 10 mm,
tolerance grade C11 / JS9 / P9 / H9 / inch

D min. 22 - 45 mm
B = 5 - 20

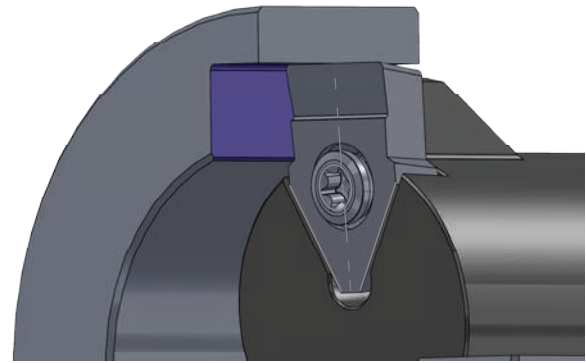
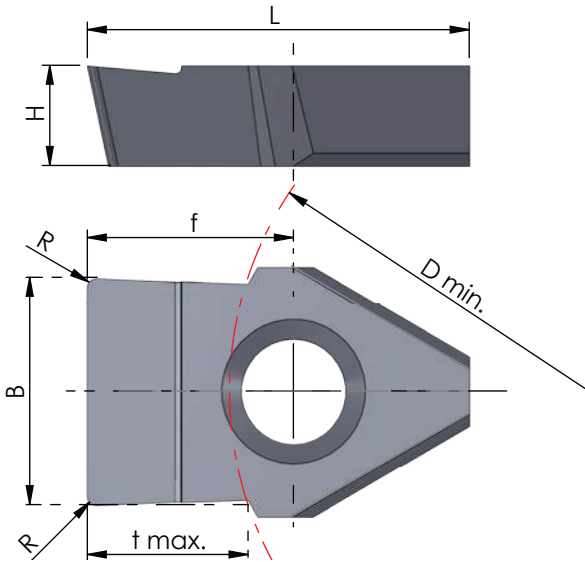

Abmessungen in mm

dimensions in mm



Bestellnummer part number	Abmessungen in mm							Schneideinsatz nach DIN	insert according DIN	für Klemmhalter for toolholder type		
	D min.	B	R	f	L	t max.	H			K10F	AL41F	P18C
NPV.1013.105	38	10.13	1.05	10.9	20.1	4.2	5.3	C11 DIN 138 Standard	●	●	●	NHV.38..(NHV.30/22..)
NPV.1215.135	38	12.15	1.35	10.9	20.1	5.1	5.3		●	●	●	NHV.38..(NHV.30/22..)
NPV.1215.175	38	12.15	1.75	10.9	20.1	6.6	5.3		●	●	●	NHV.38..(NHV.30/22..)
NPV.1215.225	38	12.15	2.25	10.9	20.1	8.5	5.3		●	●	●	NHV.38..(NHV.30/22..)
NPV.100H.03	38	10.02	0.3	8	17.3	4.2	5.3	H9 DIN 6885	●	●	●	NHV.38..(NHV.30/22..)
NPV.120H.03	38	12.02	0.3	10.9	20.1	5.7	5.3		●	●	●	NHV.38..(NHV.30/22..)

Klemmhalter in Klammer sind nicht optimal in der Unterstützung. Schnittwerte reduzieren!
Weitere HM Sorten können Sie in der Sortenübersicht im Kapitel "Technische Hinweise" und der Preisliste finden.
Bestellbeispiel:
für Sorte AL41F:
NPV.1013.105/AL41F

Please note that toolholders in brackets are not the optimal choice. If using them, please reduce the cutting data!
More carbide grades you can find in the grades summary in the chapter "technical instructions" and in the price list.
order-example:
grade AL41F:
NPV.1013.105/AL41F

NUTSTOSEN

von Längsnuten nach
DIN 138 und DIN 6885

broaching keyways according
DIN 138 und DIN 6885

NV15. ...45.1 / Typ NPV. ...45.1

Schneideinsatz
Fasen 45°

D min. 15 mm
D min. 22 / 38 mm

insert
chamfering 45°

D min. 15 mm
D min. 22 / 38 mm

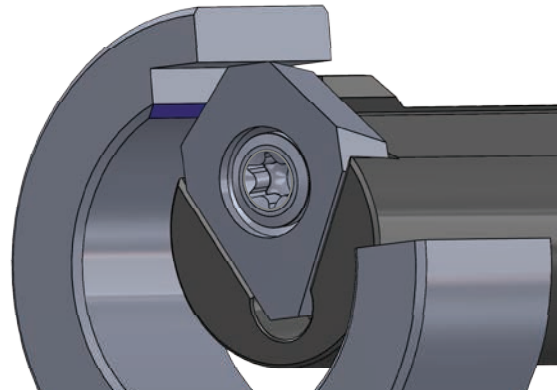
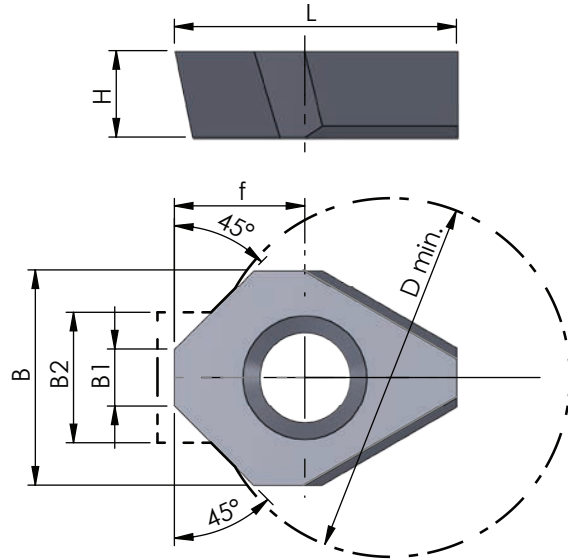

Abmessungen in mm

dimensions in mm

Bestellnummer part number	D min.	B	B1	B2 Nutenbreite width of groove	H	f	L	für Klemmhalter for toolholder type			
								K10F	AL41F	P18C	
NV15.4545.1	15	10.4	2.5	5 - 8	3.2	6.5	13	●			NHV.15....
Bestellnummer part number	D min.	B	B1	B2 Nutenbreite width of groove	H	f	L	K10F	AL41F	P18C	für Klemmhalter for toolholder type
NPV.3045.1	22	13.2	3.5	6 - 10	5.3	8	17.3	●			NHV.22....
NPV.6045.1	38	13.2	6.0	10 - 12	5.3	10.9	20.2	●			NHV.38....(NHV.30/22. ...)



Klemmhalter in Klammer sind nicht optimal in der Unterstützung. Schnittwerte reduzieren!
Weitere HM Sorten können Sie in der Sortenübersicht im Kapitel "Technische Hinweise" und der Preisliste finden.
Bestellbeispiel:
für Sorte AL41F:
NPV.3045.1/AL41F

Please note that toolholders in brackets are not the optimal choice. If using them, please reduce the cutting data!
More carbide grades you can find in the grades summary in the chapter "technical instructions" and in the price list.
order-example:
grade AL41F:
NPV.3045.1/AL41F

NUTSTOSEN

von Längsnuten nach
DIN 138 und DIN 6885

broaching keyways according
DIN 138 und DIN 6885

Typ NPU.SW

Schneideinsatz
für Innensechskant

insert
for hexagon socket

Schlüsselweite ab SW 2.5 - 8 mm

wrench size from 2.5 - 8 mm

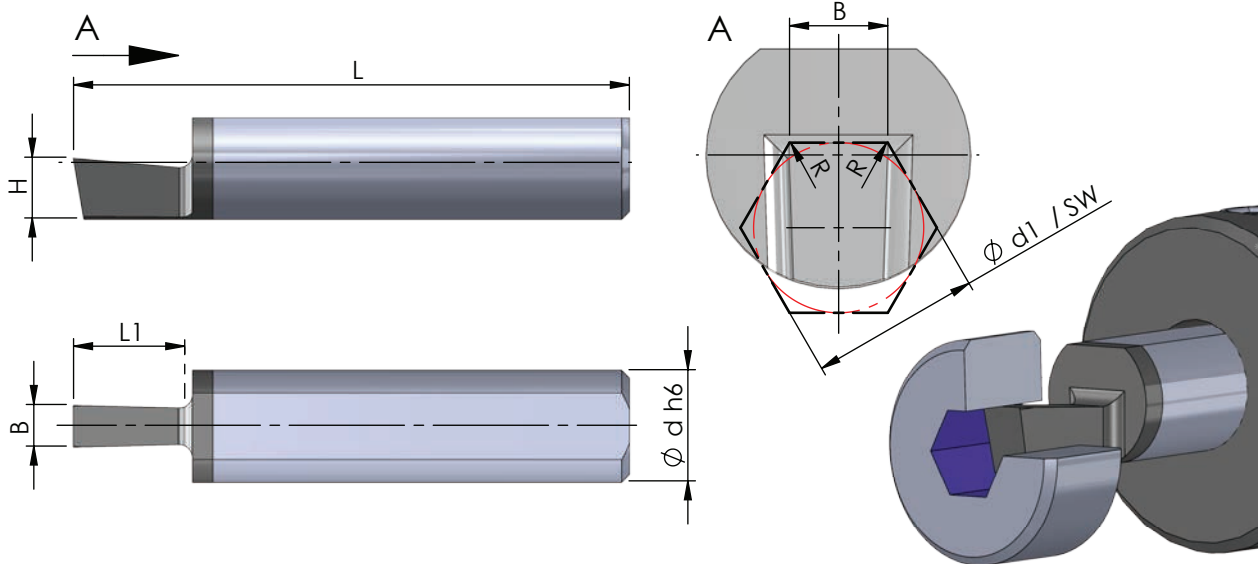

Nutmaß nach DIN

width of the groove according to DIN

Abmessungen in mm

dimensions in mm



Bestellnummer part number	Schlüsselweite SW wrench size	Ø d1 Bohrung Ø d1 hole	B	H +0.05	R	L	L1	Ø d h6	Material			für Klemmhalter for toolholder type
									K10F	AL41F	P18C	
NPU.SW25.25.01	2.5	2.5	1.48	2.0	0.05	30	4.5	7	●	●	●	NHU...
NPU.SW30.30.01	3.0	3.0	1.77	2.5	0.05	30	5.0	7	●	●	●	
NPU.SW35.35.01	3.5	3.5	2.07	2.9	0.05	30	6.0	7	●	●	●	
NPU.SW40.40.01	4.0	4.0	2.35	3.3	0.05	35	6.5	7	●	●	●	
NPU.SW45.45.01	4.5	4.5	2.64	3.8	0.1	35	7.5	7	●	●	●	
NPU.SW50.50.01	5.0	5.0	2.95	4.2	0.1	35	9.5	7	●	●	●	
NPU.SW60.60.01	6.0	6.0	3.53	5.2	0.1	35	9.5	7	●	●	●	
NPU.SW80.80.01	8.0	8.0	4.70	5.7	0.1	37	12.5	7	●	●	●	

Weitere HM Sorten können Sie in der Sortenübersicht im Kapitel "Technische Hinweise" und der Preisliste finden.

Bestellbeispiel:
für Sorte AL41F:
NPU.SW25.25.01/AL41F

More carbide grades you can find in the grades summary in the chapter "technical instructions" and in the price list.

order-example:
grade AL41F:
NPU.SW25.25.01/AL41F

NUTSTOSEN

von Längsnuten nach
DIN 138 und DIN 6885

broaching keyways according
DIN 138 und DIN 6885

Typ NP10.SW

Schneideinsatz
für Innensechskant

insert
for hexagon socket

Schlüsselweite ab SW 10 - 16 mm

wrench size from 10 - 16 mm

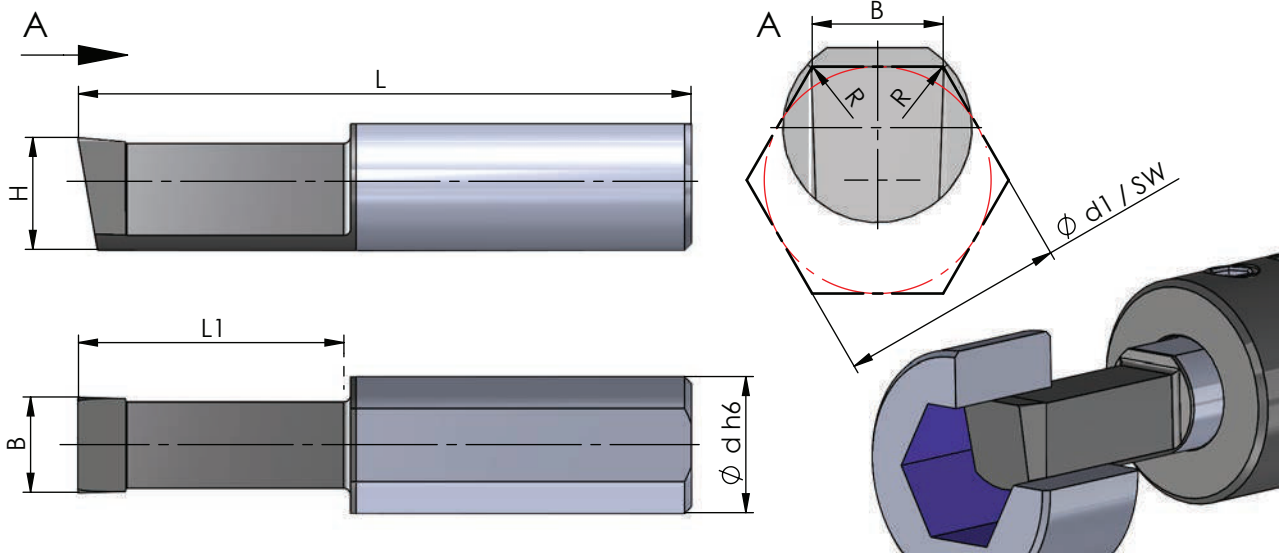

Nutmaß nach DIN	width of the groove according to DIN
Abmessungen in mm	dimensions in mm

Bestellnummer part number	Schlüsselweite SW wrench size	Ø d1 Bohrung Ø d1 hole	B	H +0.05	R	L	L1	Ø d h6	K10F AL41F P18C	für Klemmhalter for toolholder type
NP10.SW10.10.02	10	10	5.85	9.0	0.2	40	15	10	●	NH10...
NP10.SW12.12.03	12	12	7.02	8.2	0.3	45	20	10	●	
NP10.SW14.14.03	14	14	8.18	7.5	0.3	45	20	10	●	
NP10.SW16.16.04	16	16	9.34	6.2	0.4	50	25	10	●	



Weitere HM Sorten können Sie in der Sortenübersicht im Kapitel "Technische Hinweise" und der Preisliste finden.

Bestellbeispiel:
für Sorte AL41F:
NPU.SW10.10.02/AL41F

More carbide grades you can find in the grades summary in the chapter "technical instructions" and in the price list.

order-example:
grade AL41F:
NPU.SW10.10.02/AL41F

NUTSTOSEN

von Längsnuten nach
DIN 138 und DIN 6885

broaching keyways according
DIN 138 und DIN 6885

Sets

SET - NPU

Toleranzklasse JS9

tolerance grade JS9

SET - NP10

Toleranzklasse JS9

tolerance grade JS9

Bestellnummer
part number

Inhalt
Content

K10F
AL41F
P18C

SET - NPU



- Toleranzklasse JS9
D min. 6
B = 2 / 3 / 4

- tolerance grade JS9
D min. 6
B = 2 / 3 / 4

Halter / toolholder:

1 x NHU.0025.1

Schneideinsatz / insert:

1 x NPU.0200.01.1

1 x NPU.0300.01.1

1 x NPU.0400.01.1



Bestellnummer
part number

Inhalt
Content

K10F
AL41F
P18C

SET - NP10



- Toleranzklasse JS9
D min. 10
B = 4 / 5

- tolerance grade JS9
D min. 10
B = 4 / 5

Halter / toolholder:

1 x NH10.0025.1

Schneideinsatz / insert:

1 x NP10.400.02.3

1 x NP10.500.02.3



NUTSTOSSEN

von Längsnuten nach
DIN 138 und DIN 6885

broaching keyways according
DIN 138 und DIN 6885

Sets

SET - NPV

Toleranzklasse JS9

tolerance grade JS9

	Bestellnummer part number	Inhalt Content	K10F AL41F P18C
	<p>SET - NPV</p> <ul style="list-style-type: none"> • Toleranzklasse JS9 D min. 22 / 30 B = 5.01 / 6.01 / 8.01 • tolerance grade JS9 D min. 22 / 30 B = 5.01 / 6.01 / 8.01 	<p>Halter / toolholder: 1 x NHV.22.0025.1</p> <p>Schneideinsatz / insert: 1 x NPV.0501.02 1 x NPV.0601.02 1 x NPV.0801.02</p>	<p>● ● ●</p>
<p>Bestellbeispiel: SET-NPV</p>		<p>order-example: SET-NPV</p>	



NUTSTOSSEN

von Längsnuten nach
DIN 138 und DIN 6885

broaching keyways according
DIN 138 und DIN 6885

Technische Hinweise

Grundsätzliche Informationen zum Nutstossen

Technical instructions,
Basic informations about broaching keyways

Grundsätzliche Informationen zum Nutstossen

- Achten Sie auf den Freistich am Ende der geräumten Nut, damit das Werkzeug frei auslaufen kann.
- Während das Werkzeug zurückfährt, sollte die Schneide den Nutengrund nicht berühren.
- Das ausjustieren des Werkzeuges ist unerlässlich. Überprüfen sie deshalb den Durchmesser des Werkstückes genau, bevor Sie den ersten Einsatz fahren.
- Wenn Sie Öl oder eine Emulsion verwenden, werden die Späne vom Werkstück weggespült und Sie erzielen gleichzeitig eine perfekte Oberfläche.
- Wenn Sie das Werkzeug nach oben hin ausrichten, fallen die Späne automatisch nach unten, von der Schneide weg.
- Vermeiden Sie einen unterbrochenen Schnitt

Basic informations about broaching keyways

- an undercut is necessary at the end of the broached groove for tool run out.
- the insert should not touch the bottom of the groove as the tool retracts.
- setting of the tool is very important. Check accurate the component diameter before taking the first pass.
- using oil or emulsion helps to achieve better surface finish and flush chips out of the component.
- the tool should be set at the 12 o'clock position to ensure that chips fall away from the groove.
- avoid interrupted cutting.

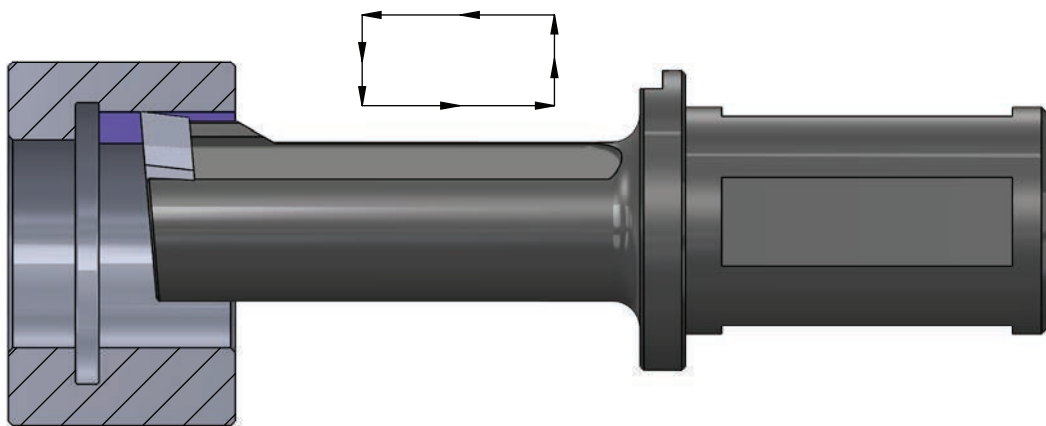

NUTSTOSEN

von Längsnuten nach
DIN 138 und DIN 6885

broaching keyways according
DIN 138 und DIN 6885

Impressionen

impressions

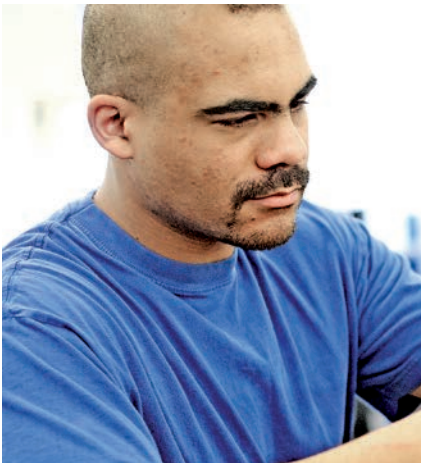
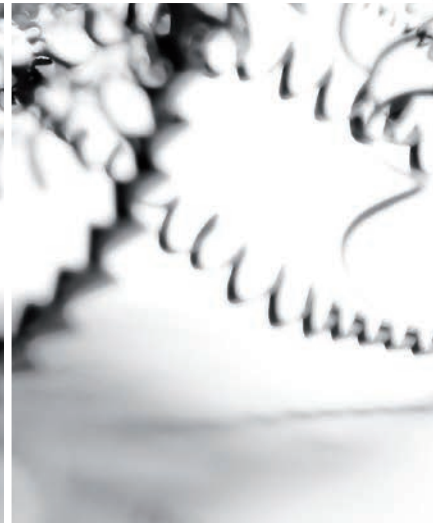
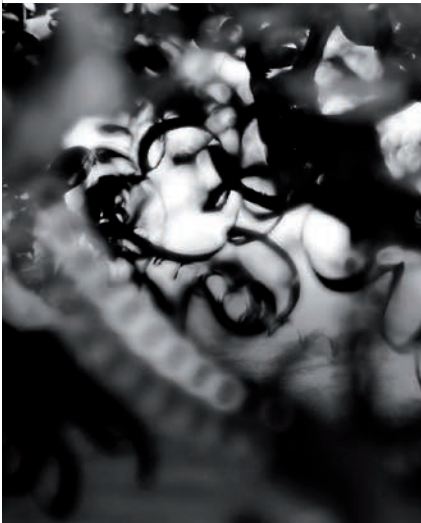
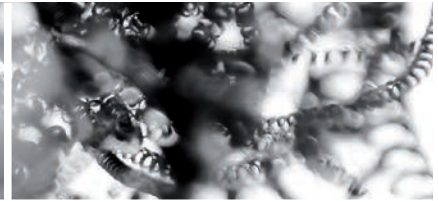

NUTSTOSSEN

von Längsnuten nach
DIN 138 und DIN 6885

broaching keyways according
DIN 138 und DIN 6885

Technische Hinweise

Hartmetallsorten und Beschichtungen

Technical instructions,
carbide grades and coatings

K10F

Universell einsetzbares Feinkornhartmetall mit guter Verschleißfestigkeit. Unbeschichtet geeignet für Anwendungen mit niedrigen und mittleren Schnittgeschwindigkeiten, sowie die Bearbeitung von Nicht-eisenmetallen.

All purpose micrograin carbide with good abrasion resistance. Uncoated for applications with low or medium cutting speeds and machining of non-ferrous materials.

CBN

Zähe CBN-Sorte für Anwendungen mit niedrigen Schnittgeschwindigkeiten. Geeignet für gehärtete Stähle, unterbrochene Schnitte und Grauguss.

Ductile CBN grade for applications with lower cutting speed. Suitable for hardened steel, interrupted cuts and cast iron.

CN45F

Universell einsetzbare PVD-TIN-Beschichtung. Diese Allround-Sorte ist für niedrige und mittlere Schnittgeschwindigkeiten mit Einschränkung bei NE-Metallen

PVD-TIN coating - all purpose, all around grade is suitable for low and medium cutting speed with restrictions on non-ferrous materials.

AL41F

Sehr universell einsetzbare TIALN-Beschichtung mit hoher Temperaturbeständigkeit bei hoher Härte. Sehr gut geeignet auch für NE-Metalle.

TIALN coating - very universal with a high resistance to high temperature and hardness. Very suitable also for non-ferrous metals.

PD2F

Beschichtung für den universellen Einsatz bei niedrigen und mittleren Schnittgeschwindigkeiten.

Coating for universal use with medium and low speed.

XC2A

Beschichtung mit einer excellenten Warmhärte, Oxidationsbeständigkeit und thermischen Isolationsfähigkeit. Ideal für Hartzerspannung >60HRC

Coating with excellent hot hardness, high oxidation resistance and thermal insulation capacity. Perfect for hard machining >60 HRC.



NUTSTOSSEN

von Längsnuten nach
DIN 138 und DIN 6885

broaching keyways according
DIN 138 und DIN 6885

Technische Hinweise

Hartmetallsorten und Beschichtungen

Technical instructions,
carbide grades and coatings

P01C

Beschichtung für die Bearbeitung in zähen Materialien bei niedrigen und mittleren Schnittgeschwindigkeiten.

Coating for the processing in tough material with medium or low cutting speed

P03C

Beschichtung für die Bearbeitung von schwer zerspanbaren Materialien. Sehr gut auch für die Trockenbearbeitung geeignet.

Coating for materials which are difficult to machine. Perfect to use for dry machining.

P07C

Beschichtung für die Bearbeitung von Titan, Edelstahl und Molybdän.

Coating to machine titanium, stainless steel and molybdenum.

P18C

Universell einsetzbare Hochleistungsschicht mit hoher Oxidationsbeständigkeit, Verschleißfestigkeit und Warmhärte.

Very universal high performance coating with high oxidation resistance, wear resistance and hot hardness resistance.

NEME

Beschichtung für die Bearbeitung von Aluminium, Al-Legierungen, NE-Metallen und Composite-Werkstoffen.

Coating for machining aluminium, alloys, non-ferrous metals and composite materials.



NUTSTOSSEN

von Längsnuten nach
DIN 138 und DIN 6885

broaching keyways according
DIN 138 und DIN 6885

Technische Hinweise

Schnittdaten

Technical instructions,
cutting data

Richtwerte zum Nutenstossen

approximate value for broaching

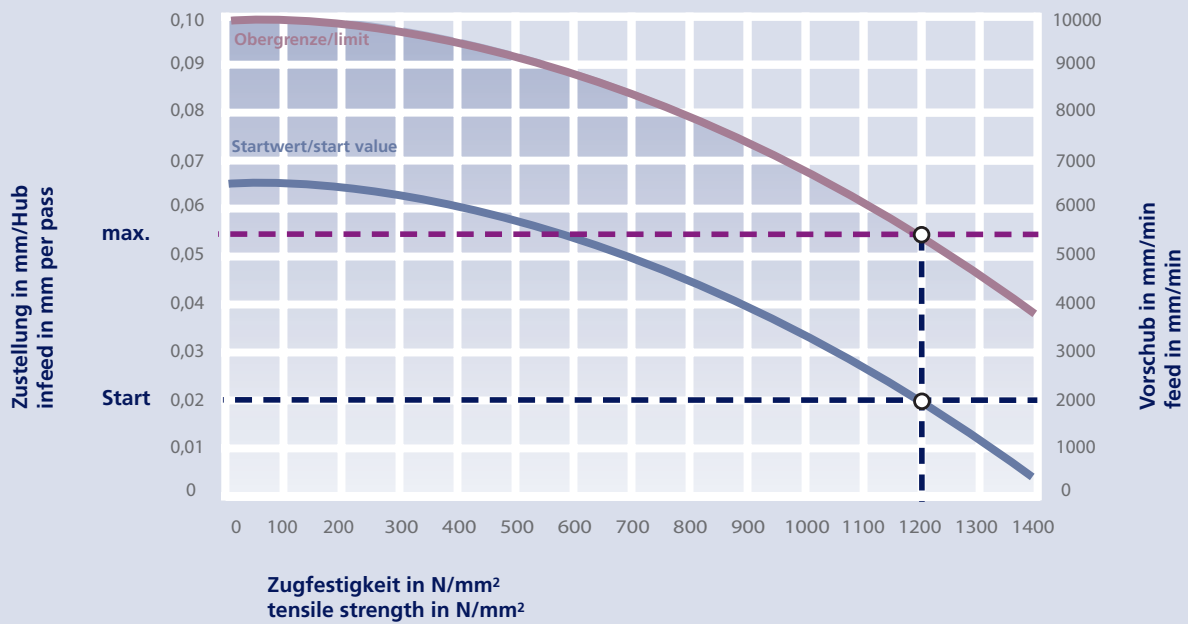

Beispiel:

Vergütungsstahl z.B.
42CrMo4 mit 1200 N/mm²

- Zustellung pro Hub
0.02 - 0.055 mm
- Vorschub
2000 - 5500 mm/min

example:

heat-treated steel
for instance 42CrMo4
with 1200 N/mm²

- infeed per pass
0.02 - 0.055 mm
- feed 2000 - 5500 mm/min

NUTSTOSEN

von Längsnuten nach
DIN 138 und DIN 6885

broaching keyways according
DIN 138 und DIN 6885

Impressionen

impressions

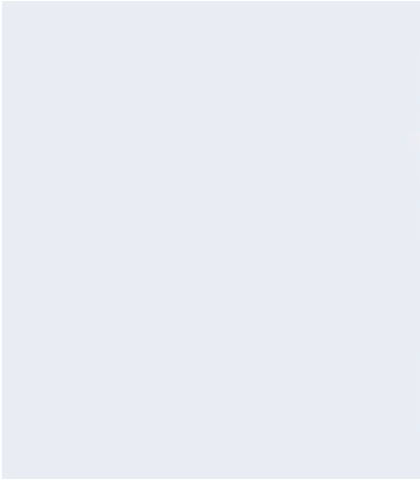

Fräsen milling

Inhalt

content

	MIKROMILL	Nut- und Formzirkularfräsen drei- und vierschneidig, ab Ø 1.3 mm	312	
	MINIMILL	Nut- und Formzirkularfräsen drei- und sechsschneidig, ab Ø 10 mm	334	
	SYSTEM 500	Nut- und Formfräsen Nut- und Trennfräsen	430	
	rotaline	Ausspindeln ab Ø 0.4 mm	460	



MIKROMILL



**Nut- und Formzirkularfräsen drei- und vierschneidig
ab Ø 1.3 mm**

**Groove milling by circular interpolation with
three and four cutting edges starting at Ø 1.3 mm**

MIKROMILL

Nut- und Formzirkularfräsen

groove milling
by circular interpolation

Übersicht

summary

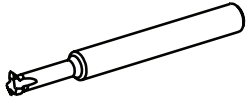

Allgemeine Beschreibung

general instructions

... 315

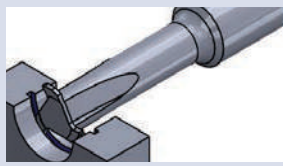

**Schneidplatten
Nutfräsen**

**inserts
groove milling**

**Maße
dimensions**

**Seite
page**

Typ MA6 / MA8

Nutfräsen allgemein

groove milling general use

D min. 6 / 8

... 316

Typ MB6 / MB8

Nutfräsen allgemein

groove milling general use

D min. 6 / 8

... 317

Typ MA6 / MA8 / MA10

Nutfräsen
Vollradius

groove milling
full radius

D min.
4 / 6 / 8 / 10

... 318

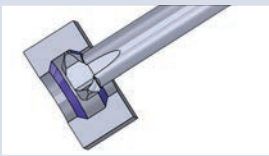

**Schneidplatten
Vorwärts- und
Rückwärtsfasen**

**inserts
forward and backward
chamfering**

**Maße
dimensions**

**Seite
page**

Typ MA6 / MA8

Vorwärts- und Rückwärtsfasen

forward and backward chamfering

D min. 6 / 8

... 319

Typ MB6 / MB8

Vorwärts- und Rückwärtsfasen

forward and backward chamfering

D min. 6 / 8

... 320

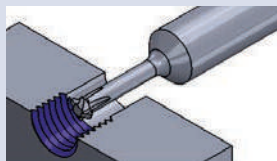

**Schneidplatten
Gewindefräsen, innen**

**inserts
threading, internal**

**Maße
dimensions**

**Seite
page**

Typ MA3 / MA5

metrisches ISO-Gewinde,
Teilprofil, innen

metric ISO-thread,
partial profile, internal

ab / starting at
M2 x 0.4

... 321

**Typ MA3 / MA5 /
MA6 / MA8**

metrisches ISO-Feingewinde,
Teilprofil, innen

metric ISO-fine thread,
partial profile, internal

ab / starting at
M1.6 x 0.35

... 322

Typ MB6 / MB8

metrisches ISO-Feingewinde,
Teilprofil, innen

metric ISO-fine thread,
partial profile, internal

ab / starting at
M7 x 0.5

... 323

Typ MA4 / MA6

metrisches ISO-Gewinde,
Vollprofil, innen

metric ISO-thread,
full profile, internal

ab / starting at
M3 x 0.35

... 324

Typ MA8 / MA10

metrisches ISO-Gewinde,
Vollprofil, innen

metric ISO-thread,
full profile, internal

ab / starting at
M8 x 0.75

... 325

MIKROMILL

Nut- und Formzirkularfräsen

groove milling
by circular interpolation

Übersicht

summary

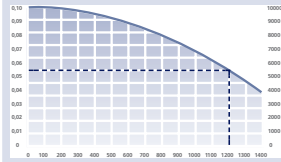

Technische Hinweise

Technical Instructions

Seite
page

Grundsätzliche Informationen zum Gewindefräsen	Basic informations about thread milling	... 327
Hartmetallsorten und Beschichtungen	carbide grades and coatings	...329
Schnittdaten	cutting data	... 331

MIKROMILL

Nut- und Formzirkularfräsen

groove milling
by circular interpolation

Allgemeine Beschreibung

general instruction

Mikromill:

Werkzeuge mit Rundschaft für das Nutfräsen und Fasen ab \varnothing 6 mm und Gewindefräsen ab M1.6 im Standard.

Mikromill:

Tools with round shaft for groove milling and chamfering starting at \varnothing 6 mm and thread machining starting with a thread of M1.6 in standard.

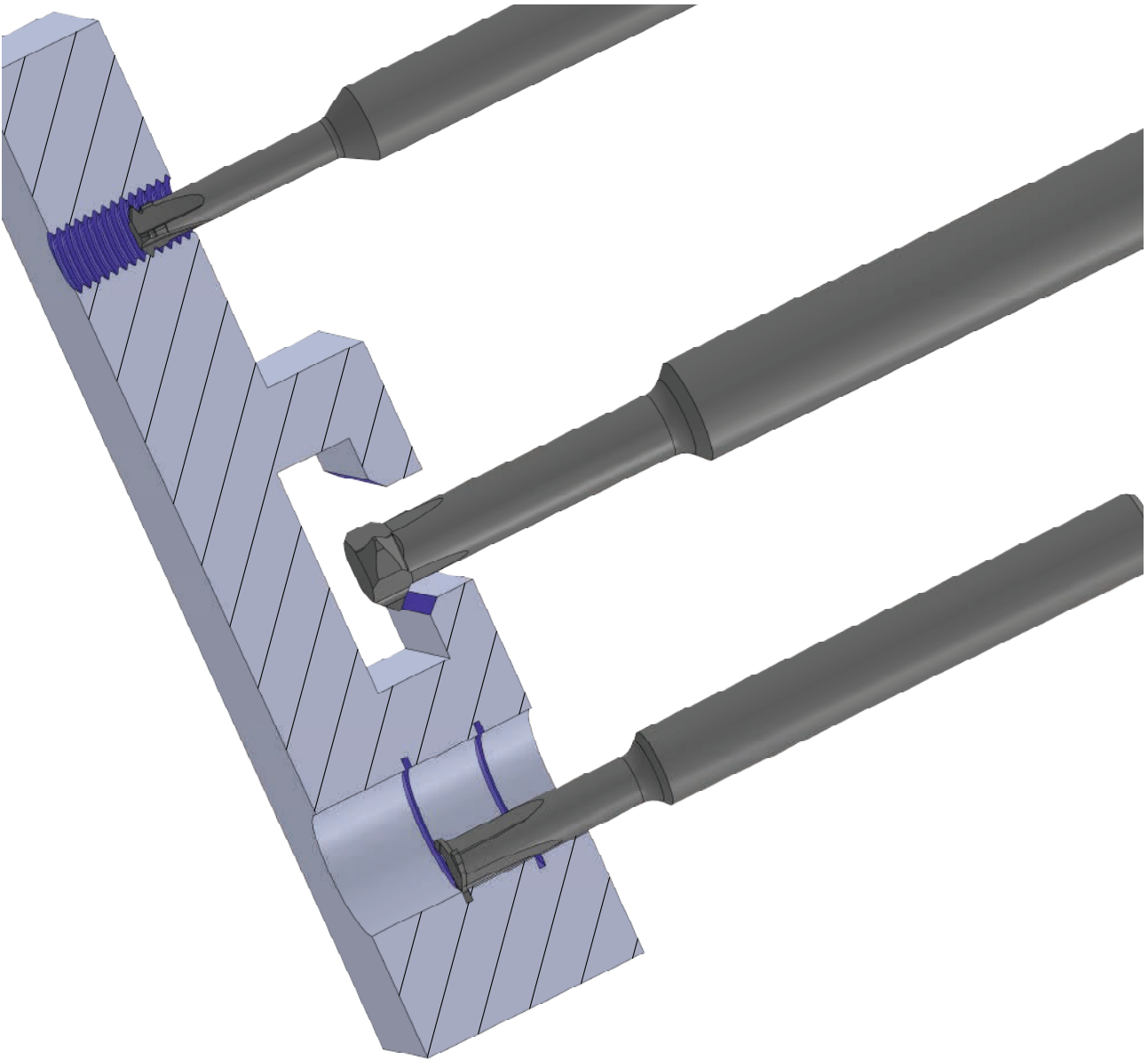

MIKROMILL

Nut- und Formzirkularfräsen

groove milling
by circular interpolation

Typ MA6 / MA8

Nutfräsen allgemein

groove milling general use

D min. 6 / 8 mm

D min. 6 / 8 mm

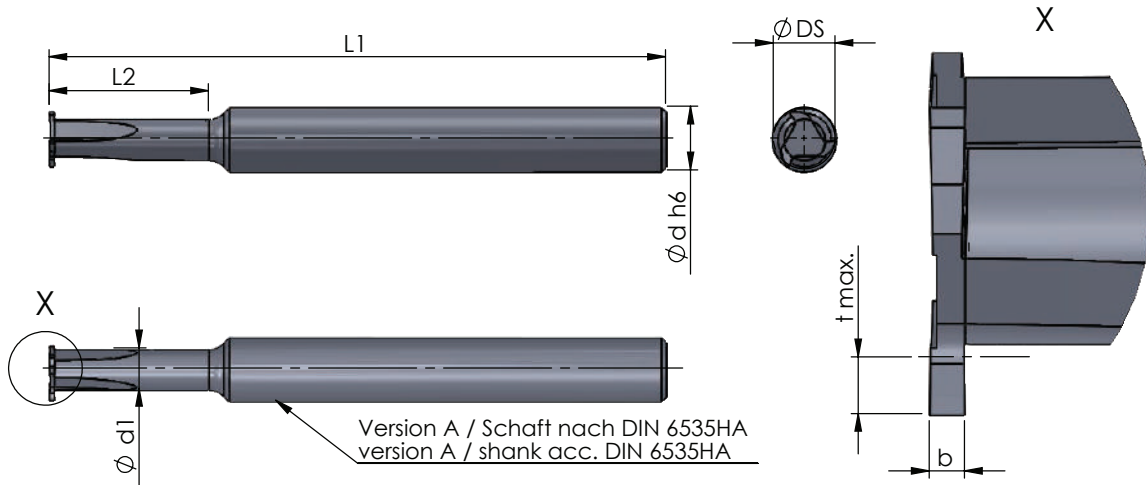

Version A / Schaft nach DIN 6535HA
version A / shank acc. DIN 6535HA

Abmessungen in mm

dimensions in mm

Bestellnummer part number	Abmessungen in mm / dimensions in mm									Schneidzahn cutting edge		
	D min.	b ± 0.02	L2	L1	Ø d h6	Ø d1	Ø DS	t max.	Schneidzahn cutting edge	K10F	AL41F	P18C
MA6.0050.00-15	6	0.5	15	58	6	3.8	5.8	0.8	3	●		
MA6.0060.00-15	6	0.6	15	58	6	3.8	5.8	0.8	3	●		
MA6.0070.00-15	6	0.7	15	58	6	3.8	5.8	0.8	3	●		
MA6.0080.00-15	6	0.8	15	58	6	3.8	5.8	0.8	3	●		
MA6.0090.00-15	6	0.9	15	58	6	3.8	5.8	0.8	3	●		
MA6.0100.00-15	6	1.0	15	58	6	3.8	5.8	0.8	3	●		
MA6.0150.00-15	6	1.5	15	58	6	3.8	5.8	0.8	3	●		
MA8.0070.00-25	8	0.7	25	68	8	5	7.8	1.2	3	●		
MA8.0080.00-25	8	0.8	25	68	8	5	7.8	1.2	3	●		
MA8.0090.00-25	8	0.9	25	68	8	5	7.8	1.2	3	●		
MA8.0100.00-25	8	1.0	25	68	8	5	7.8	1.2	3	●		
MA8.0150.00-25	8	1.5	25	68	8	5	7.8	1.2	3	●		
MA8.0200.00-25	8	2.0	25	68	8	5	7.8	1.2	3	●		

Weitere HM Sorten können Sie in der Sortenübersicht im Kapitel "Technische Hinweise" und der Preisliste finden.

Bestellbeispiel:
für Sorte AL41F:
MA6.0050.00-15/AL41F

More carbide grades you can find in the grades summary in the chapter "technical instructions" and in the price list.

order-example:
grade AL41F:
MA6.0050.00-15/AL41F

MIKROMILL

Nut- und Formzirkularfräsen

groove milling
by circular interpolation

Typ MB6 / MB8

Nutfräsen allgemein

groove milling general use

D min. 6 / 8 mm

D min. 6 / 8 mm

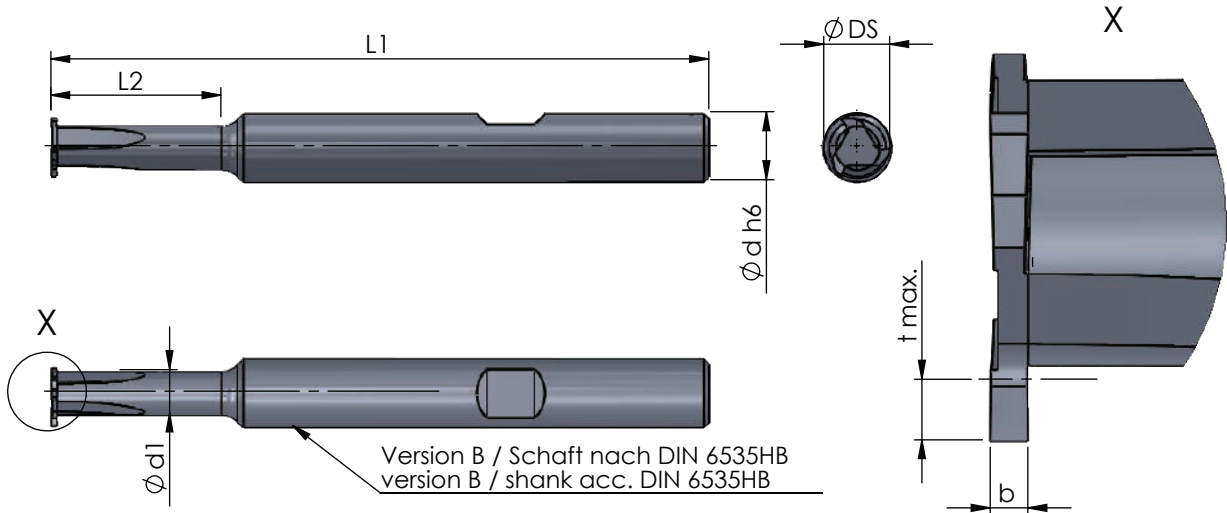

Abmessungen in mm

dimensions in mm

Bestellnummer part number	D min.	b ± 0.02	L2	L1	Ø d h6	Ø d1	Ø DS	t max.	Schneidenzahl cutting edge			
										K10F	AL41F	P18C
MB6.0050.00-15	6	0.5	15	58	6	3.8	5.8	0.8	3		●	
MB6.0060.00-15	6	0.6	15	58	6	3.8	5.8	0.8	3		●	
MB6.0070.00-15	6	0.7	15	58	6	3.8	5.8	0.8	3		●	
MB6.0080.00-15	6	0.8	15	58	6	3.8	5.8	0.8	3		●	
MB6.0090.00-15	6	0.9	15	58	6	3.8	5.8	0.8	3		●	
MB6.0100.00-15	6	1.0	15	58	6	3.8	5.8	0.8	3		●	
MB6.0150.00-15	6	1.5	15	58	6	3.8	5.8	0.8	3		●	
MB8.0070.00-25	8	0.7	25	68	8	5	7.8	1.2	3		●	
MB8.0080.00-25	8	0.8	25	68	8	5	7.8	1.2	3		●	
MB8.0090.00-25	8	0.9	25	68	8	5	7.8	1.2	3		●	
MB8.0100.00-25	8	1.0	25	68	8	5	7.8	1.2	3		●	
MB8.0150.00-25	8	1.5	25	68	8	5	7.8	1.2	3		●	
MB8.0200.00-25	8	2.0	25	68	8	5	7.8	1.2	3		●	

Weitere HM Sorten können Sie in der Sortenübersicht im Kapitel "Technische Hinweise" und der Preisliste finden.

Bestellbeispiel:
für Sorte AL41F:
MB6.0050.00-15/AL41F

More carbide grades you can find in the grades summary in the chapter "technical instructions" and in the price list.

order-example:
grade AL41F:
MB6.0050.00-15/AL41F

MIKROMILL

Nut- und Formzirkularfräsen

groove milling
by circular interpolation

Typ MA6 / MA8 / MA10

Nutfräsen
Vollradius

groove milling
full radius

D min. 4 / 6 / 8 / 10 mm

D min. 4 / 6 / 8 / 10 mm

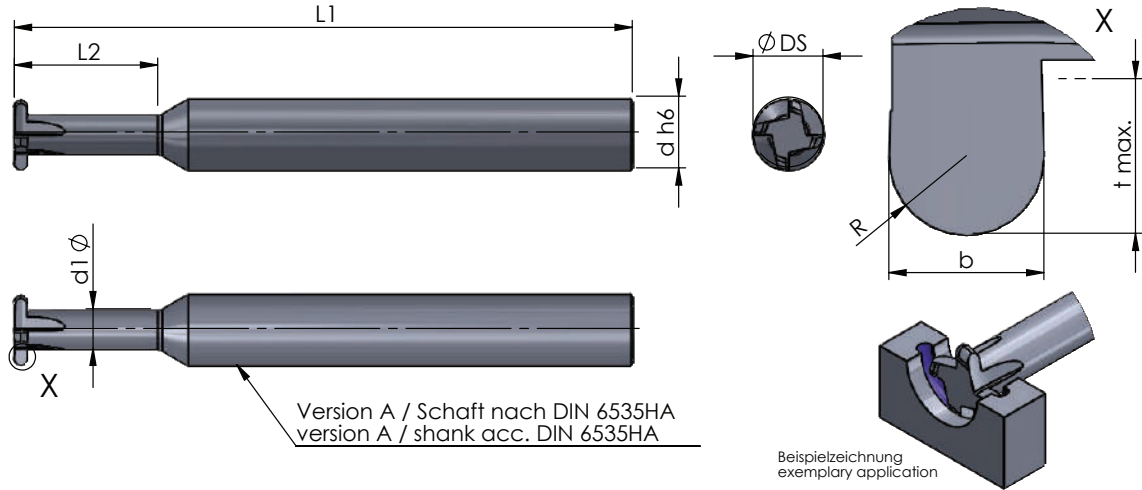

Version A / Schaft nach DIN 6535HA
version A / shank acc. DIN 6535HA

Abmessungen in mm

dimensions in mm

Bestellnummer part number	D min.	b ± 0.02	R	L2	L1	Ø d h6	Ø d1	Ø DS	t max.	Schneidenzahl cutting edge			
											K10F	AL41F	P18C
MA6.005.10-4	4	1.0	0.5	4	58	6	2.55	3.8	0.5	3			●
MA6.005.10-6	6	1.0	0.5	6	58	6	3.5	5.8	1.0	3			●
MA6.007.15-6	6	1.5	0.75	6	58	6	3.5	5.8	1.0	3			●
MA8.007.15-16	8	1.5	0.75	16	69	8	4.4	7.8	1.5	4			●
MA8.010.20-16	8	2.0	1.0	16	69	8	4.4	7.8	1.5	4			●
MA10.005.10-20	10	1.0	0.5	20	79	10	5.3	9.8	2.0	4			●
MA10.007.15-20	10	1.5	0.75	20	79	10	5.3	9.8	2.0	4			●
MA10.010.20-20	10	2.0	1.0	20	79	10	5.3	9.8	2.0	4			●
MA10.012.25-20	10	2.5	1.25	20	79	10	5.3	9.8	2.0	4			●
MA10.015.30-20	10	3.0	1.5	20	79	10	5.3	9.8	2.0	4			●

Weitere HM Sorten können Sie in der Sortenübersicht im Kapitel "Technische Hinweise" und der Preisliste finden.

Bestellbeispiel:
für Sorte P18C:
MA6.005.10-4/P18C

More carbide grades you can find in the grades summary in the chapter "technical instructions" and in the price list.

order-example:
grade P18C:
MA6.005.10-4/P18C

MIKROMILL

Nut- und Formzirkularfräsen

groove milling
by circular interpolation

Typ MA6 / MA8

Vorwärts- und Rückwärtsfasen

D min. 6 / 8 mm

forward and backward chamfering

D min. 6 / 8 mm

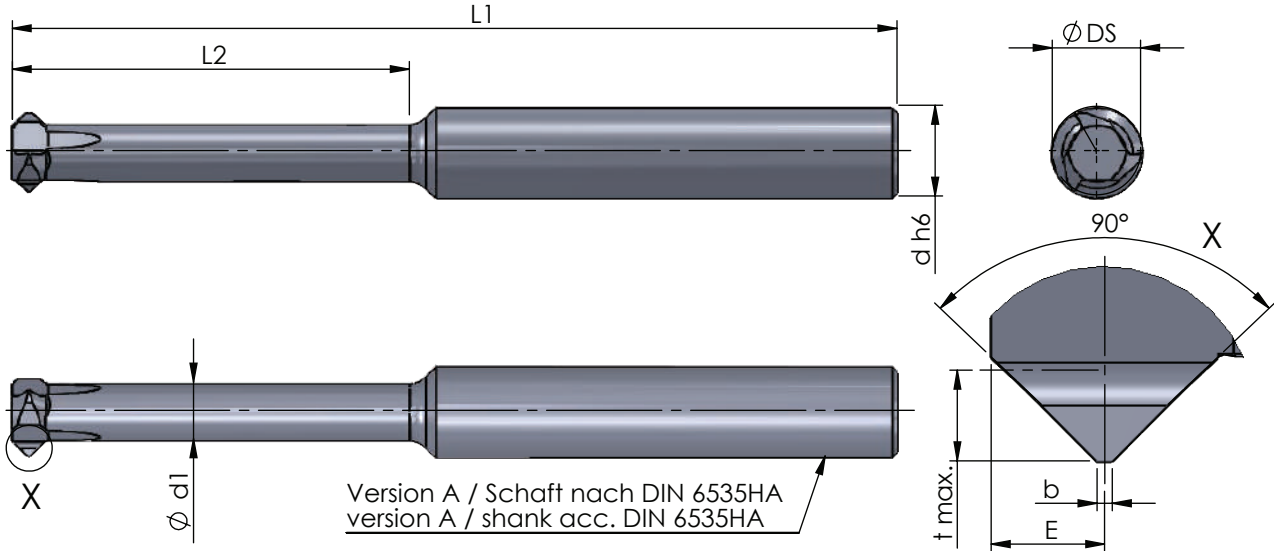

Abmessungen in mm

dimensions in mm

Bestellnummer part number	D min.	b	L2	L1	E	Ø d h6	Ø d1	Ø DS	t max.	Schneidenzahl cutting edge			
											K10F	AL41F	P18C
MA6.4545.02-15	6	0.2	15	58	1	6	4	5.8	0.6	3		●	
MA6.4545.02-25	6	0.2	25	68	1	6	4	5.8	0.6	3		●	
MA8.4545.02-25	8	0.2	25	68	1.5	8	5	7.8	1.2	3		●	
MA8.4545.02-35	8	0.2	35	78	1.5	8	5	7.8	1.2	3		●	

Weitere HM Sorten können Sie in der Sortenübersicht im Kapitel "Technische Hinweise" und der Preisliste finden.

Bestellbeispiel:
für Sorte AL41F:
MA6.4545.02-15/AL41F

More carbide grades you can find in the grades summary in the chapter "technical instructions" and in the price list.

order-example:
grade AL41F:
MA6.4545.02-15/AL41F

MIKROMILL

Nut- und Formzirkularfräsen

groove milling
by circular interpolation

Typ MB6 / MB8

Vorwärts- und Rückwärtsfasen

D min. 6 / 8 mm

forward and backward chamfering

D min. 6 / 8 mm

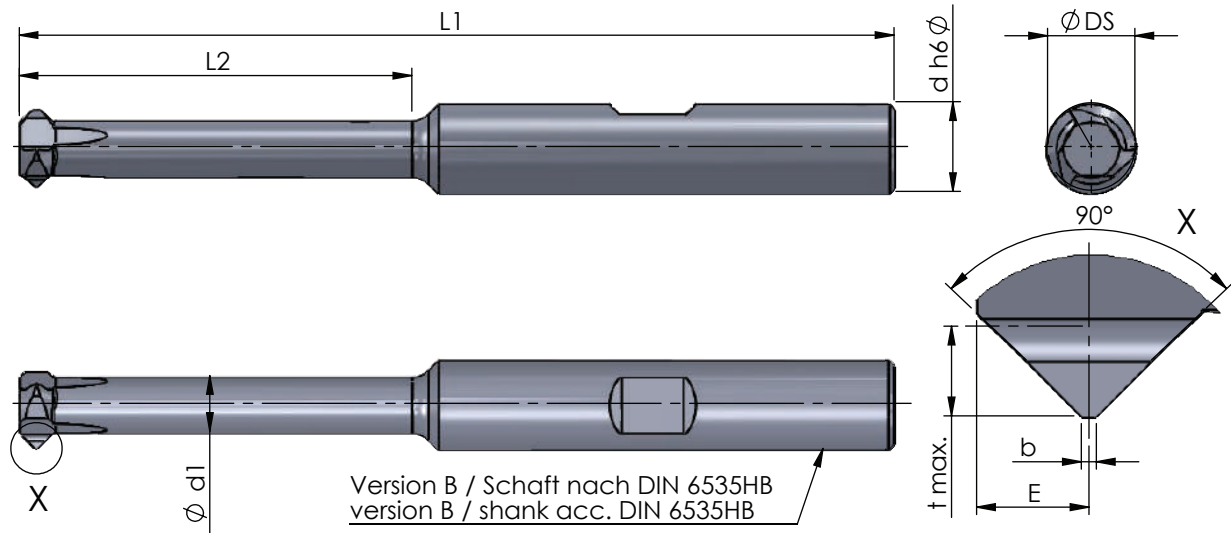

Abmessungen in mm

dimensions in mm

Bestellnummer part number	D min.	b	L2	L1	E	Ø d h6	Ø d1	Ø DS	t max.	Schneidzahl cutting edge			
											K10F	AL41F	P18C
MB6.4545.02-15	6	0.2	15	58	1	6	4.2	5.8	0.6	3		●	
MB6.4545.02-25	6	0.2	25	68	1	6	4.2	5.8	0.6	3		●	
MB8.4545.02-25	8	0.2	25	68	1.5	8	5	7.8	1.2	3		●	
MB8.4545.02-35	8	0.2	35	78	1.5	8	5	7.8	1.2	3		●	

Weitere HM Sorten können Sie in der Sortenübersicht im Kapitel "Technische Hinweise" und der Preisliste finden.

Bestellbeispiel:
für Sorte AL41F:
MB6.4545.02-15/AL41F

More carbide grades you can find in the grades summary in the chapter "technical instructions" and in the price list.

order-example:
grade AL41F:
MB6.4545.02-15/AL41F

MIKROMILL

Nut- und Formzirkularfräsen

groove milling
by circular interpolation

Typ MA3 / MA5

metrisches ISO-Gewinde,
Teilprofil, innen

metric ISO-thread,
partial profile, internal

ab Gewindegröße M2 x 0.4

starting at thread size M2 x 0.4

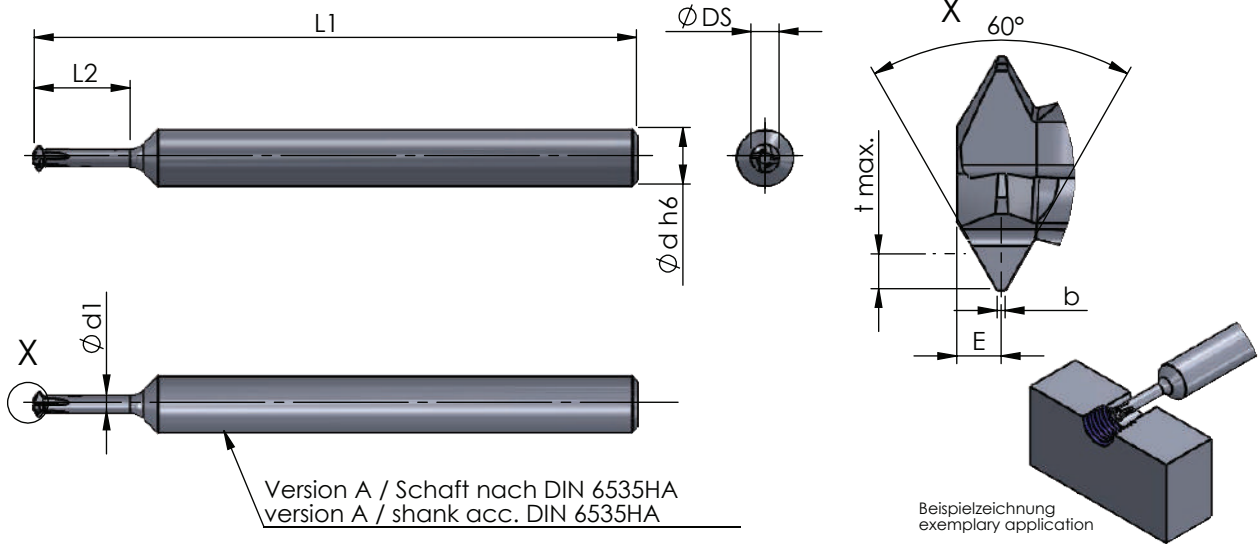

Version A / Schaft nach DIN 6535HA
version A / shank acc. DIN 6535HA

Beispielzeichnung
exemplary application

Abmessungen in mm

dimensions in mm

Bestellnummer part number	min. Gewindegröße min. thread size	Steigung P pitch P	L2	L1	b	E	t max.	Ø d h6	Ø d1	Ø DS	Schneidenzahl cutting edge	K10F	AL41F	P18C
MA3.MR20.01-5	M2	0.4-0.45	5	32	0.05	0.3	0.27	3	0.77	1.45	4	●		
MA3.MR25.01-6	M2.5	0.45-0.5	6	32	0.05	0.3	0.29	3	1.06	1.8	4	●		
MA3.MR30.01-7	M3	0.5-0.6	7	32	0.06	0.3	0.35	3	1.27	2.15	4	●		
MA3.MR35.01-8	M3.5	0.6-0.7	8	32	0.07	0.4	0.40	3	1.39	2.4	4	●		
MA5.MR40.01-9	M4	0.7-0.8	9	44	0.08	0.4	0.46	5	1.58	2.7	4	●		
MA5.MR50.01-10	M5	0.8-1.0	10	44	0.1	0.5	0.59	5	2.14	3.57	4	●		
MA5.MR60.01-12	M6	1.0-1.25	12.2	44	0.12	0.6	0.74	5	2.44	4.2	4	●		
MA5.MR70.01-15	M7	1.0-1.25	15.2	44	0.12	0.6	0.74	5	3.34	5.15	4	●		

Weitere HM Sorten können Sie in der Sortenübersicht im Kapitel "Technische Hinweise" und der Preisliste finden.

Bestellbeispiel:
für Sorte AL41F:
MA3.MR20.01-5/AL41F

More carbide grades you can find in the grades summary in the chapter "technical instructions" and in the price list.

order-example:
grade AL41F:
MA3.MR20.01-5/AL41F

MIKROMILL

Nut- und Formzirkularfräsen

groove milling
by circular interpolation

Typ MA3 / MA5 / MA6 / MA8

metrisches ISO-Feingewinde,
Teilprofil, innen

metric ISO-fine thread,
partial profile, internal

ab Gewindegröße M1.6 x 0,35

starting at thread size M1.6 x 0,35

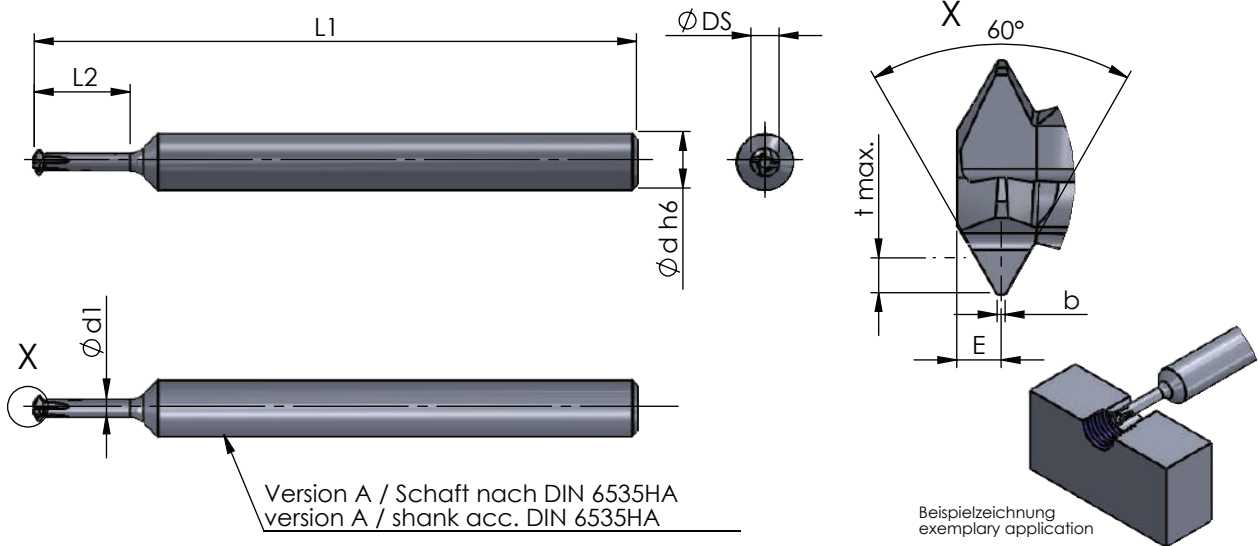

Abmessungen in mm

dimensions in mm

Bestellnummer part number	D min.	Steigung P pitch P	min. Gewindegröße min. thread size	L2	L1	b	E	t max.	Ø d h6	Ø d1	Ø DS	Schneidzahl cutting edge	K10F	AL41F	P18C
MA3.0035.01-4	1.3	0.35	M1.6	4	32	0.04	0.2	0.19	3	0.67	1.18	3	●	●	●
MA3.0035.01-5	1.58	0.35	M1.8	5	32	0.04	0.2	0.19	3	0.86	1.38	3	●	●	●
MA3.0040.01-5	2.07	0.4	M2.5	5	32	0.05	0.3	0.22	3	0.92	1.5	4	●	●	●
MA3.0045.01-6	2.52	0.45	M3.0	6	32	0.06	0.3	0.25	3	1.28	1.95	4	●	●	●
MA3.0050.01-7	2.96	0.5	M3.5	7	32	0.06	0.3	0.27	3	1.67	2.4	4	●	●	●
MA3.0060.01-8	3.35	0.6	M4.0	8	32	0.08	0.4	0.33	3	1.93	2.8	4	●	●	●
MA5.0070.01-9	3.74	0.7	M4.5	9	44	0.09	0.4	0.38	5	2.12	3.1	4	●	●	●
MA5.0080.01-10	4.63	0.8	M5.5	10	44	0.10	0.5	0.43	5	2.97	4.1	4	●	●	●
MA5.0100.01-12	5.92	1.0	M7	12	44	0.13	0.6	0.54	5	3.51	4.9	4	●	●	●
MA5.0100.01-15	6.92	1.0	M7	15	44	0.13	0.6	0.54	5	3.5	4.9	4	●	●	●
MA6.0815.01-15	6.0	0.5-1.5	M7	15	58	0.06	0.8	0.92	6	3.5	5.8	3	●	●	●
MA8.0815.01-25	8.0	0.5-1.5	M9	25	68	0.06	1.0	0.91	8	5.5	7.8	3	●	●	●
MA8.1020.01-25	8.0	1.0-2.0	M10	25	68	0.12	1.0	1.19	8	5.0	7.8	3	●	●	●

Weitere HM Sorten können Sie in der Sortenübersicht im Kapitel "Technische Hinweise" und der Preisliste finden.

Bestellbeispiel:
für Sorte AL41F:
MA3.0035.01-4/AL41F

More carbide grades you can find in the grades summary in the chapter "technical instructions" and in the price list.

order-example:
grade AL41F:
MA3.0035.01-4/AL41F

MIKROMILL

Nut- und Formzirkularfräsen

groove milling
by circular interpolation

Typ MB6 / MB8

metrisches ISO-Feingewinde,
Teilprofil, innen

metric ISO-fine thread,
partial profile, internal

ab Gewindegröße M7 x 0,5

starting at thread size M7 x 0,5

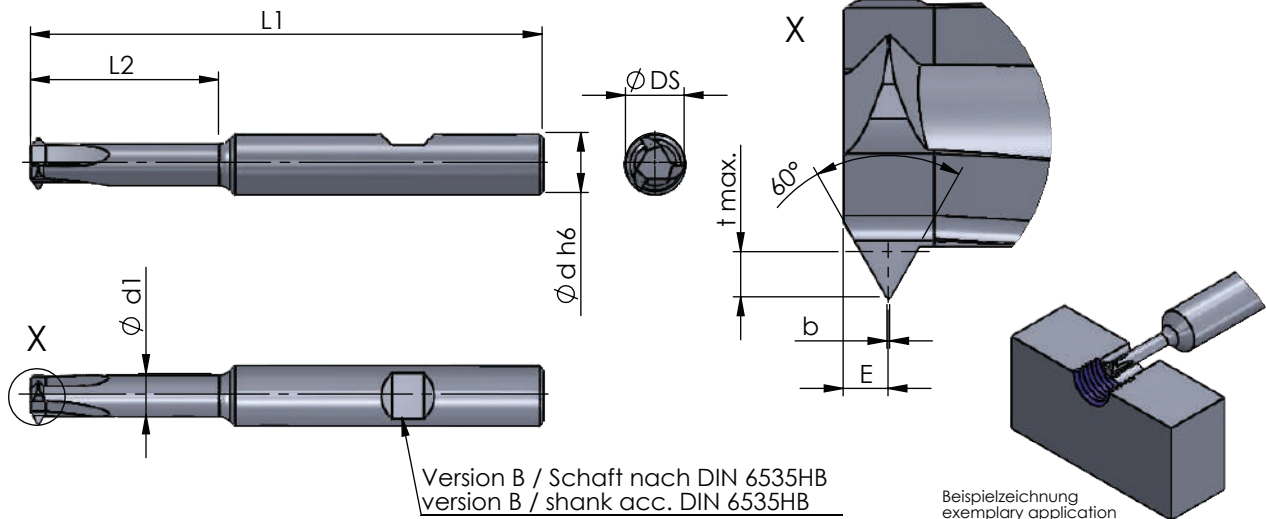

Abmessungen in mm

dimensions in mm

Bestellnummer part number	min. Gewindegröße min. thread size	Steigung P pitch P	L2	L1	b	E	t max.	Ø d h6	Ø d1	Ø DS	Schneidenzahl cutting edge	Material		
												K10F	AL41F	P18C
MB6.0815.01-15	M7	0.5-1.5	15	58	0.06	0.8	0.91	6	3.5	5.8	3	●	●	●
MB8.0815.01-25	M9	0.5-1.5	25	68	0.06	1.0	0.91	8	5.5	7.8	3	●	●	●
MB8.1020.01-25	M10	1.0-2.0	25	68	0.12	1.0	1.19	8	5.0	7.8	3	●	●	●

Weitere HM Sorten können Sie in der Sortenübersicht im Kapitel "Technische Hinweise" und der Preisliste finden.

Bestellbeispiel:
für Sorte AL41F:
MB6.0815.01-15/AL41F

More carbide grades you can find in the grades summary in the chapter "technical instructions" and in the price list.

order-example:
grade AL41F:
MB6.0815.01-15/AL41F

MIKROMILL

Nut- und Formzirkularfräsen

groove milling
by circular interpolation

Typ MA4 / MA6

metrisches ISO-Gewinde,
Vollprofil, innen

metric ISO-thread,
full profile, internal

ab Gewindegröße M3 x 0.35

starting at thread size M3 x 0.35

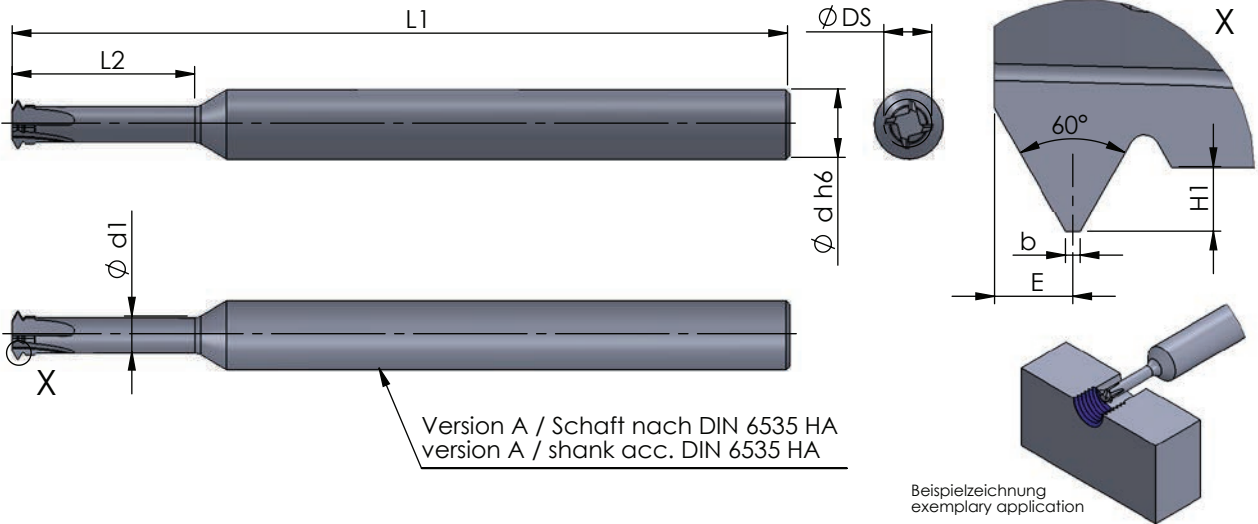

Abmessungen in mm

dimensions in mm

Bestellnummer part number	min. Gewindegröße min. thread size	Steigung P pitch P	L2	L1	b	E	H1	Ø d h6	Ø d1	Ø DS	Schneidenzahl cutting edge	K10F	AL41F	P18C
MA4.VP035-8	M3	0.35	8	44	0.04	0.2	0.19	4	1.4	2.0	3			●
MA4.VP050-8	M3	0.5	8	44	0.06	0.3	0.27	4	1.25	2.0	3			●
MA4.VP060-9	M3.5	0.6	9	44	0.08	0.3	0.33	4	1.4	2.3	3			●
MA6.VP050-10	M4	0.5	10	58	0.06	0.3	0.27	6	2.0	2.8	3			●
MA6.VP070-10	M4	0.7	10	58	0.09	0.4	0.38	6	1.85	2.8	3			●
MA6.VP075-16	M6	0.75	16	68	0.1	0.5	0.41	6	3.1	4.2	4			●
MA6.VP100-16	M6	1.0	16	68	0.12	0.6	0.54	6	2.8	4.2	4			●
MA6.VP125-16	M8	1.25	16	68	0.16	0.75	0.68	6	3.7	5.5	4			●

Weitere HM Sorten können Sie in der Sortenübersicht im Kapitel "Technische Hinweise" und der Preisliste finden.

Bestellbeispiel:
für Sorte P18C:
MA4.VP035-8/P18C

More carbide grades you can find in the grades summary in the chapter "technical instructions" and in the price list.

order-example:
grade P18C:
MA4.VP035-8/P18C

MIKROMILL

Nut- und Formzirkularfräsen

groove milling
by circular interpolation

Typ MA8 / MA10

metrisches ISO-Gewinde,
Vollprofil, innen

metric ISO-thread,
full profile, internal

ab Gewindegröße M8 x 0.75

starting at thread size M8 x 0.75

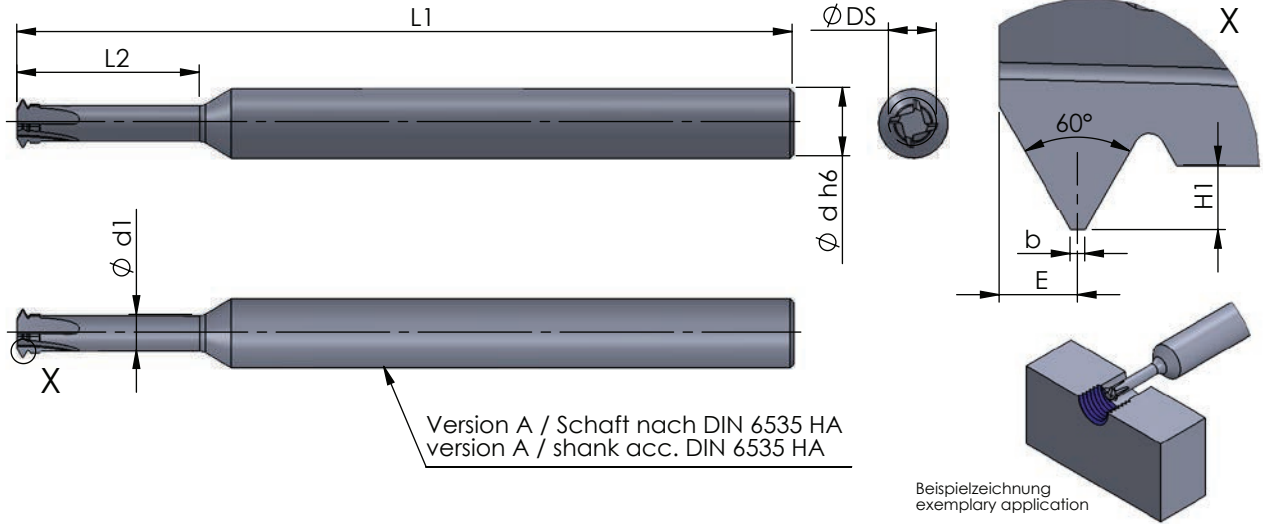

Abmessungen in mm

dimensions in mm

Bestellnummer part number	min. Gewindegröße min. thread size	Steigung P pitch P	L2	L1	b	E	H1	Ø d h6	Ø d1	Ø DS	Schneidenzahl cutting edge	K10F	AL41F	P18C
MA8.VP075-16	M8	0.75	16	69	0.1	0.5	0.41	8	4.3	5.5	4			●
MA8.VP075-20	M10	0.75	20	69	0.1	0.5	0.41	8	5.6	6.8	4			●
MA8.VP100-16	M8	1.0	16	69	0.12	0.6	0.54	8	4.0	5.5	4			●
MA8.VP100-25	M10	1.0	25	79	0.12	0.6	0.54	8	5.4	6.8	4			●
MA8.VP125-16	M8	1.25	16	69	0.16	0.8	0.68	8	3.7	5.5	4			●
MA8.VP150-20	M10	1.5	20	69	0.19	1.0	0.81	8	4.7	6.8	4			●
MA10.VP100-20	M12	1.0	20	69	0.12	0.6	0.54	10	6.3	8.0	4			●
MA10.VP125-30	M12	1.25	30	79	0.16	0.8	0.68	10	6.1	8.0	4			●
MA10.VP175-30	M12	1.75	30	79	0.22	1.0	0.95	10	5.5	8.0	4			●

Weitere HM Sorten können Sie in der Sortenübersicht im Kapitel "Technische Hinweise" und der Preisliste finden.

Bestellbeispiel:
für Sorte P18C:
MA8.VP075-16/P18C

More carbide grades you can find in the grades summary in the chapter "technical instructions" and in the price list.

order-example:
grade P18C:
MA8.VP075-16/P18C

MIKROMILL

Nut- und Formzirkularfräsen

groove milling
by circular interpolation

Impressionen

impressions

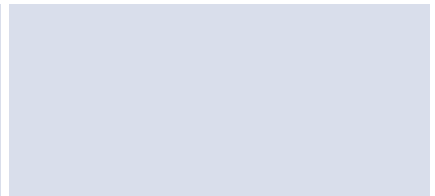
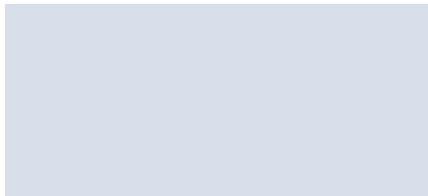
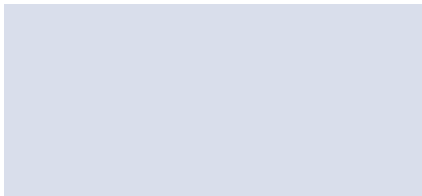
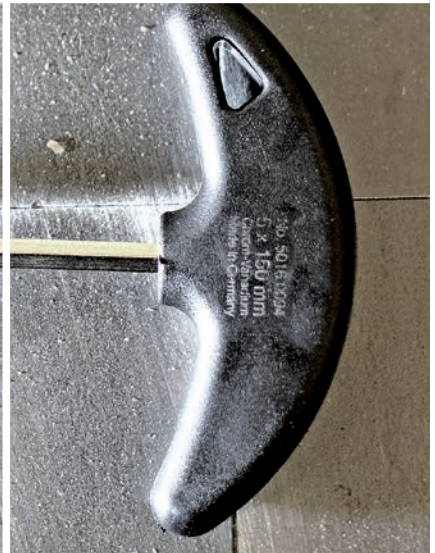
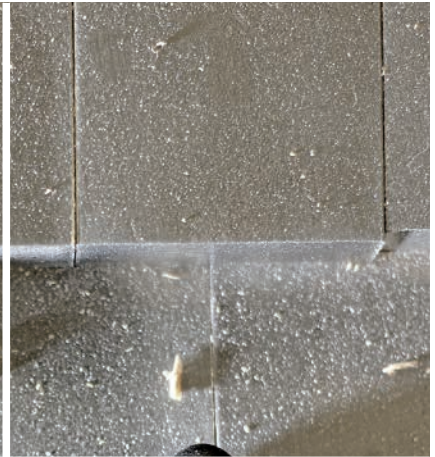

MIKROMILL

Nut- und Formzirkularfräsen

groove milling
by circular interpolation

Technische Hinweise

Grundsätzliche Informationen zum Gewindefräsen

Technical instructions,
basic informations about thread milling

Vor- und Nachschnitt

Beim Zirkularfräsen von Gewinden entsteht durch die Steigung ein Vor- und Nachschnitt. Um hier die Verletzung des Gewindeprofils so gering wie möglich zu halten muß ein Werkzeug mit einem möglichst kleinen Schneidkreis gewählt werden. Die nachfolgende Skizze zeigt die Verhältnisse bei der Bearbeitung:
(Grün: Konturverletzung X gering = gut; Rot: Konturverletzung X erheblich = schlecht)

Thread profile violation

Thread milling by interpolation causes a profile violation. To keep the violation minimal you should use the cutting circle as small as possible.

The following sketch shows the relations during the process:

(green: profile violation X low = good; red: profile violation X big = bad)

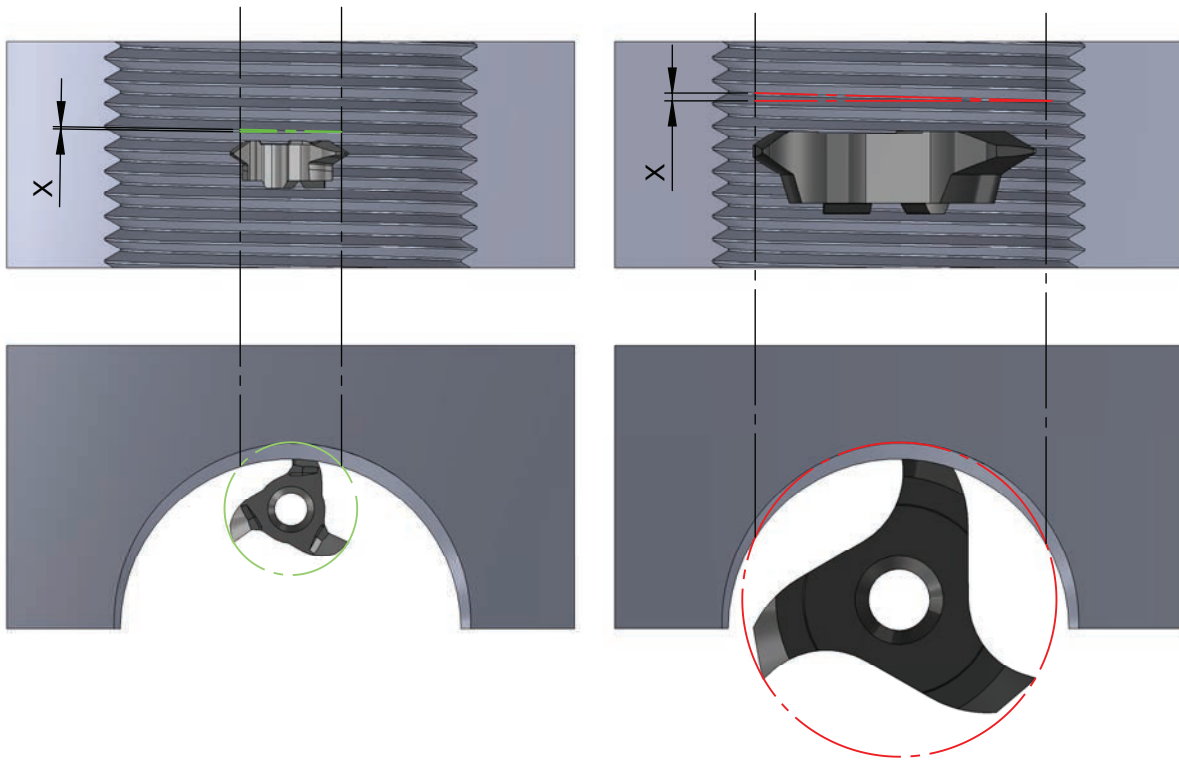

MIKROMILL

Nut- und Formzirkularfräsen

groove milling
by circular interpolation

Technische Hinweise

Grundsätzliche Informationen zum Gewindefräsen

Technical instructions,
basic informations about thread milling

Teilprofil

Werkzeuge mit Teilprofil sind Mehrbereichswerkzeuge, d.h. mit diesem Werkzeug können Gewinde mit unterschiedlichen Steigungen hergestellt werden. Dies ist aber nur mit einer kleinen Abweichung vom Normprofil möglich. Abgestimmt ist das Werkzeug auf die kleinste angegebene Steigung, dieses Profil kann ohne Abweichung produziert werden. Alle weiteren Steigungen können ebenfalls produziert werden, hier weicht aber das gefertigte Profil gegenüber der Norm durch eine höhere Gewindetiefe ab. In der Regel ist dies unproblematisch, muß aber gegebenenfalls im Einzelfall genauer betrachtet werden.

Partial profile

Tools with partial profile are multi-purpose tools, that means you can process several pitches with one tool. The processed shape has a small difference to the standard profile. Created is that tool for the smallest pitch, this profile depends to the standard.

All other pitches are producible, but only with a small deviation. Normally this causes no problem, but sometimes you have to decide case by case.

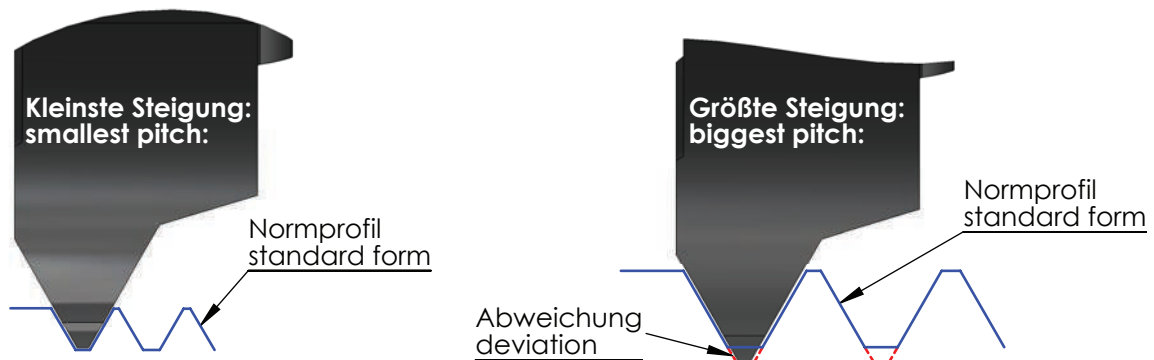

Auswahlhilfe Mehrbereichswerkzeuge

In der nachfolgenden Tabelle sind alle DÜMMEL - Mehrbereichswerkzeuge aufgeführt. Anhand dieser Tabelle können Sie den jeweiligen Einsatzbereich entnehmen (blau= optimale Kontur, grau= mögliche Konturen):

Selection guide multi-purpose-tools

In the following chart are all DÜMMEL - multi-purpose-tools listed. This chart shows the possible area of application (blue= optimal profile; grey= possible profiles):

ab Gewindegröße / starting with thread-size	Steigung (mm)/ pitch (mm)																	
	0,5	0,6	0,7	0,8	0,9	1	1,1	1,2	1,25	1,3	1,4	1,5	1,6	1,7	1,75	1,8	1,9	2
MA/MB 6.0815.01-15	M6,5	M7	M7	M7,5	M8	M8	M8,5	M8,5	M8,5	M8,5	M9	M9						
MA/MB 8.0815.01-25	M8,5	M9	M9,5	M9,5	M10	M10	M10,5	M10,5	M10,5	M11	M11	M11						
MA/MB 8.1020.01-25						M10	M10,5	M10,5	M10,5	M11	M11	M11	M11,5	M11,5	M11,5	M11,5	M11,5	M12

MIKROMILL

Nut- und Formzirkularfräsen

groove milling
by circular interpolation

Technische Hinweise

Hartmetallsorten und Beschichtungen

Technical instructions,
carbide grades and coatings



K10F

Universell einsetzbares Feinkornhartmetall mit guter Verschleißfestigkeit. Unbeschichtet geeignet für Anwendungen mit niedrigen und mittleren Schnittgeschwindigkeiten, sowie die Bearbeitung von Nicht-eisenmetallen.

All purpose micrograin carbide with good abrasion resistance. Uncoated for applications with low or medium cutting speeds and machining of non-ferrous materials.

CBN

Zähe CBN-Sorte für Anwendungen mit niedrigen Schnittgeschwindigkeiten. Geeignet für gehärtete Stähle, unterbrochene Schnitte und Grauguss.

Ductile CBN grade for applications with lower cutting speed. Suitable for hardened steel, interrupted cuts and cast iron.

CN45F

Universell einsetzbare PVD-TiN-Beschichtung. Diese Allround-Sorte ist für niedrige und mittlere Schnittgeschwindigkeiten mit Einschränkung bei NE-Metallen

PVD-TiN coating - all purpose, all around grade is suitable for low and medium cutting speed with restrictions on non-ferrous materials.

AL41F

Sehr universell einsetzbare TiAlN-Beschichtung mit hoher Temperaturbeständigkeit bei hoher Härte. Sehr gut geeignet auch für NE-Metalle.

TiAlN coating - very universal with a high resistance to high temperature and hardness. Very suitable also for non-ferrous metals.

PD2F

Beschichtung für den universellen Einsatz bei niedrigen und mittleren Schnittgeschwindigkeiten.

Coating for universal use with medium and low speed.

XC2A

Beschichtung mit einer excellenten Warmhärte, Oxidationsbeständigkeit und thermischen Isolationsfähigkeit. Ideal für Hartzerspannung >60HRC

Coating with excellent hot hardness, high oxidation resistance and thermal insulation capacity. Perfect for hard machining >60 HRC.

MIKROMILL

Nut- und Formzirkularfräsen

groove milling
by circular interpolation

Technische Hinweise

Hartmetallsorten und Beschichtungen

Technical instructions,
carbide grades and coatings

P01C

Beschichtung für die Bearbeitung in zähen Materialien bei niedrigen und mittleren Schnittgeschwindigkeiten.

Coating for the processing in tough material with medium or low cutting speed



P03C

Beschichtung für die Bearbeitung von schwer zerspanbaren Materialien. Sehr gut auch für die Trockenbearbeitung geeignet.

Coating for materials which are difficult to machine. Perfect to use for dry machining.

P07C

Beschichtung für die Bearbeitung von Titan, Edelstahl und Molybdän.

Coating to machine titanium, stainless steel and molybdenum.

P18C

Universell einsetzbare Hochleistungsschicht mit hoher Oxidationsbeständigkeit, Verschleißfestigkeit und Warmhärte.

Very universal high performance coating with high oxidation resistance, wear resistance and hot hardness resistance.

NEME

Beschichtung für die Bearbeitung von Aluminium, Al-Legierungen, NE-Metallen und Composite-Werkstoffen.

Coating for machining aluminium, alloys, non-ferrous metals and composite materials.

MIKROMILL

Nut- und Formzirkularfräsen

groove milling
by circular interpolation

Technische Hinweise

Schnittdaten

Technical instructions,
cutting data



	Werkstoff	Festigkeit	Werkstoff-Nr	Werkstoffbezeichnung	Werkstoff-Nr	
P	Allgemeiner Baustahl	< 800 N/mm2	1.0037	St37-2	1.0570	
	Automatenstahl	< 800 N/mm2	1.0718	9SMnPb28	1.0727	
	Einsatzstahl unlegiert	< 800 N/mm2	1.0401	C15	1.0481	
	Einsatzstahl legiert	< 1000 N/mm2	1.7331	16MnCr5 (EC80)	1.7015	
	Vergütungsstahl unlegiert	< 850 N/mm2	1.0503	C45	1.1191	
	Vergütungsstahl unlegiert	< 1000 N/mm2	1.0601	C60	1.1221	
	Vergütungsstahl legiert	< 800 N/mm2	1.5131	50MnSi4	1.7030	
	Vergütungsstahl legiert	< 1300 N/mm2	1.5755	31NiCr14	1.7033	
	Stahlguss	< 850 N/mm2	0.9650	G-X260Cr27	1.6750	
	Nitrierstahl	< 1000 N/mm2	1.8504	34CrAl6	1.8507	
	Nitrierstahl	< 1200 N/mm2	1.8515	31CrMo12	1.8523	
	Wälzlagerstahl	< 1200 N/mm2	1.3505	100Cr6 (W3)	1.3543	
	Federstahl	< 1200 N/mm2	1.5026	55Si7	1.7176	
	Schnellarbeitsstahl	< 1300 N/mm2	1.3344	S 6-5-3	1.3255	
	Werkzeugstahl für Kaltarbeit	< 1300 N/mm2	1.2312	40CrMnMoS8 6	1.2379	
	Werkzeugstahl für Warmbeit	< 1300 N/mm2	1.2343	X38CrMoV 5 1	1.2767	
	M	Stahl und Stahlguss rostfrei geschwefelt	< 850 N/mm2	1.4305	X8CrNiS18 9	1.4105
		Nichtrostender Stahl, ferritisch	< 750 N/mm2	1.4510	X3CrTi17	1.4528
Nichtrostender Stahl, martensitisch		< 900 N/mm2	1.4034	X46Cr13	1.4116	
Nichtrost. Stahl, ferritisch/martensit.		<1100 N/mm2	1.4313	X3CrNi13-4	1.4028	
Nichtrost. Stahl, austenitisch/ferritisch		< 850 N/mm2	1.4460	X8CrNiMo27 5	1.4821	
Nichtrostender Stahl, austenitisch		< 750 N/mm2	1.4301	X5CrNi18-10	1.4571	
Hitzebeständig		< 1100 N/mm2	1.4747	X80CrNiSi20	1.4876	
K	Grauguss mit Lammellengraphit	100-350N/mm2	0.6010	GG10	0.6025	
	Grauguss mit Lammellengraphit	300-1000N/mm2	0.6030	GG30	0.6045	
	Kugelgraphitguss	300-500N/mm2	0.7040	GGG40	0.7050	
	Kugelgraphitguss	550-800N/mm2	0.7060	GGG60	0.7080	
	Temperguss weis	350-450N/mm2	0.8035	GTW35	0.8045	
	Temperguss weis	500-650N/mm2	0.8055	GTW55	0.8065	
	Temperguss schwarz	350-450N/mm2	0.8135	GTS35	0.8145	
Temperguss schwarz	500-700N/mm2	0.8155	GTS55	0.8170		
N	Aluminium (unlegiert, niedrig legiert)	< 350 N/mm2	3.0255	Al99,5	3.3308	
	Aluminiumlegierungen < 0,5% Si	< 500 N/mm2	3.0515	AlMn1	3.1355	
	Aluminiumlegierungen 0,5-10% Si	< 400 N/mm2	3.2152	GD-AlSi6Cu4	3.2373	
	Aluminiumlegierungen 10-15% Si	< 400 N/mm2	3.2381	G-AlSi10Mg	3.5562	
	Aluminiumlegierungen > 15% Si	< 400 N/mm2		G-AlSi17Cu4		
	Kupfer (unlegiert, niedrig legiert)	< 350 N/mm2	2.0060	E-Cu57	2.0090	
	Kupfer-Knetlegierungen	< 700 N/mm2	2.0240	CuZn15	2.0265	
	Kupfer-Sonderlegierungen	< 200 HB	2.0916	CuAl5	2.1525	
	Kupfer-Sonderlegierungen	< 300HB	2.0978	CuAl11Ni6Fe5		
	Kupfer-Sonderlegierungen	> 300 HB	2.1247	CuBe2F125		
	Messing kurzspanend, Bronze, Rotguss	< 600 N/mm2	2.0360	CuZn40 (Ms60)	2.0380	
	Messing langspanend	< 600 N/mm2	2.0335	CuZn36 (Ms63)	2.1293	
	Thermoplaste			Delrin, Hostalen		
	Duroplaste			Ferrozell, Bakelit		
	Faserverstärkte Kunststoffe			GFK (Glasfaserverstärkt)		
	Magnesium und Magnesiumlegierungen	< 850 N/mm2	3.5200	M2, MgMn2	3.5612	
	Graphit			C8000, R8500X		
Wolfram und Wolframlegierungen			W-NiFe (Densimet W)			
Molybdän und Molybdänlegierungen			Mo , Mo-50Re			
S	Reinnickel		1.3911	RNi24	1.3927	
	Nickellegierungen		1.3912	Ni36 (Invar)	1.3924	
	Nickellegierungen	< 850 N/mm2	2.4360	S-NiCu 30 Fe		
	Nickel-Chromlegierungen		2.4886	SG-NiMo16Cr16W	2.4610	
	Nickel- und Kobaltlegierungen	< 1300 N/mm2	2.4632	NiCr20Co18Ti	2.4631	
	Nickel- und Kobaltlegierungen	< 1300 N/mm2	2.4634	NiCo20Cr15MoAlTi	2.4654	
	Hochwärmefeste Legierungen	< 1300 N/mm2		Hardox 400	1.4939	
	Nickel-Kobalt-(Chrom-)legierungen	< 1400 N/mm2	2.4806	SG-NiCr20Nb, Inconel 82	2.4851	
	Reintitan	< 900 N/mm2	3.7025	Ti99,8	3.7034	
	Titanlegierungen	< 700 N/mm2	3.7114	TiAl5Sn2	3.7174	
	Titanlegierungen	< 1200 N/mm2	3.7164	TiAl5V4	3.7144	
H	Stahl gehärtet	< 45 HRc				
		46-55HRc				
		56-60 HRc				
		61-65 HRc				
	65-70 HRc					

MIKROMILL

Nut- und Formzirkularfräsen

groove milling
by circular interpolation

Technische Hinweise

Schnittdaten

Technical instructions,
cutting data



Werkstoffbezeichnung	Werkstoff- Nr	Werkstoffbezeichnung	Vc (m/min.)	fz (mm)	
St52-3	1.0060	St60-2	40-120	0,02 - 0,05	Haupt-Anwendung
45S20	1.0757	46SPb2		0,02 - 0,05	
17Mn4	1.1141	C15E (CK15)		0,02 - 0,05	
13Cr3 (EC60)	1.5919	15CrNi6	40-110	0,01 - 0,04	
Ck45	1.0535	C55	0,02 - 0,05		
Ck60	1.0540	C50	0,01 - 0,04		
28Cr4	1.7225	42CrMo4	30-110	0,02 - 0,05	
34Cr4	1.3565	48CrMo4		0,007 - 0,03	
GS-20NiCrMo3 7	1.6582	GS-34 CrNiMo 6		0,02 - 0,05	
34AlMo5	1.8509	41CrAlMo7		0,01 - 0,04	
39CrMoV19 3	1.8550	34 CrAlNi 7	0,007 - 0,02		
X192CrMo17	1.3520	100 CrMn 6 (W4)	10-60	0,005 - 0,01	
55Cr3	1.7701	51CrMoV4		0,005 - 0,01	
S 18-1-2-5	1.3294	PMH56-5-3-8; ASP30		0,005 - 0,01	
X155CrVMo12 1	1.2316	X38CrMo16; RAMAX	60-120	0,005 - 0,01	
X45NiCrMo4	1.2842	90MnCrV8		0,005 - 0,01	
X4CrMoS18	1.4107	GX8CrNi12		0,01 - 0,04	
X105CrCoMo18 2	1.4016	X6Cr17		0,02 - 0,05	
X50CrMoV15	1.4106	X2CrMoSi18-2-1	0,007 - 0,03		
X30Cr13	1.4104	X14CrMoS17	0,007 - 0,03		
X20CrNiSi25 4	1.4462	X2CrNiMoN22-5-3 (Duplex)	0,007 - 0,03		
X6CrNiMoTi17 12 2	1.4449	X3CrNiMo18-12-3	0,007 - 0,03		
X10NiCrAlTi32-21	1.4825	GX25CrNiSi18-9	0,007 - 0,03		
GG25			50-120	0,02 - 0,05	
GG45				0,02 - 0,05	
GGG50				0,02 - 0,05	
GGG80				0,02 - 0,05	
GTW45				0,02 - 0,05	
GTW65				0,02 - 0,05	
GTS45				0,02 - 0,05	
GTS70				0,02 - 0,05	
Al99,9Mg0,5	3.0256	E-Al H	70-140	0,02 - 0,07	
AlCuMg2	3.3315	AlMg1		0,02 - 0,07	
GD-AlSi9Mg	3.2134	GD-AlSi5Cu1Mg		0,02 - 0,07	
G-MgAl6	3.2525	S-AlSi12	0,02 - 0,07		
G-AlSi25CuNiMg		G-AlSi21CuNiMg	0,02 - 0,07		
SF-Cu	2.1522	CuSi2Mn	70-140	0,02 - 0,07	
CuZn30	2.0321	CuZn37		0,02 - 0,07	
CuSi3Mn		Ampco 8-16		0,02 - 0,07	
		Ampco18-26		0,02 - 0,07	
		Ampco M-4	0,02 - 0,07		
CuZn39Pb2 (Ms58)	2.0410	CuZn44Pb2	60-130	0,02 - 0,07	
CuCrZr	2.1080	CuSn6Zn6		0,02 - 0,07	
Makrolon, Novodur		Acrylglas, Polystyrol	10-50	0,02 - 0,1	
Pertinax		Resopal		0,02 - 0,1	
CFK (Kohlefaserverstärkt)		AFK (Amidfaserverstärkt)	10-50	0,02 - 0,07	
MgAl6Zn1	3.5812	MgAl8Zn1		0,02 - 0,05	
R8650		Technograph15		0,02 - 0,07	
W-Cu80/20		W93NiFe (DENAL)		0,02 - 0,05	
TZC, TZM		MHC , ODS		0,02 - 0,05	
RNi8	1.3926	RNi12	10-60	0,007 - 0,02	
Ni54	1.3921	Ni49		0,007 - 0,02	
NiCu 30 Fe		Monel 400		0,007 - 0,02	
NiMo16Cr16Ti		Hastelloy C-276		0,007 - 0,02	
NiCr20TiAl		Nimonic 80		0,007 - 0,02	
NiCr19Co14Mo4Ti		Waspaloy		0,007 - 0,02	
X12CrNiMo12	1.4980	X6NiCrTiMoVB25-15-2		0,007 - 0,02	
NiCr23Fe, Inconel 601	2.4667	SG-NiCr19NbMoTi		0,007 - 0,02	
Ti99,7	3.7064	Ti99,5		0,007 - 0,02	
TiAl6V6Sn2	3.7124	TiCu2		0,007 - 0,02	
TiAl6Sn2Zr4Mo2	3.7154	TiAl6Zr5	0,007 - 0,02		
			10-40	0,007 - 0,02	
				0,007 - 0,02	
			-	-	Neben-Anwendung
			-	-	

Für das Gewindefräsen kann die Schnittgeschwindigkeiten reduziert werden, da sonst die maximale Drehzahl überschritten wird.

For thread milling the cutting speed can be reduced, because the maximum speed is reached.

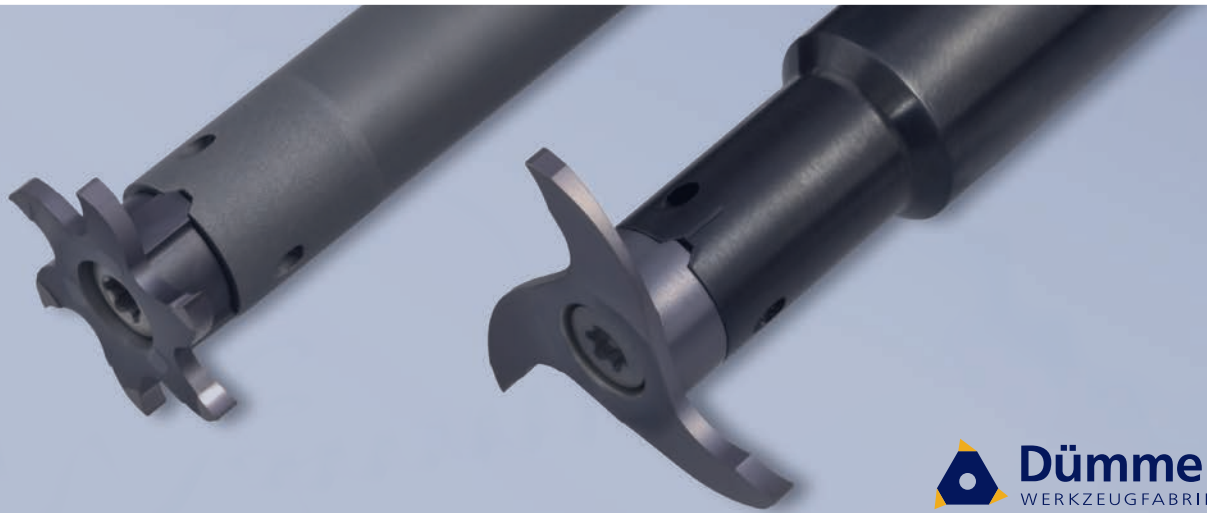

 **Dümmel**[®]
WERKZEUGFABRIK

MINIMILL



**Nut- und Formzirkularfräsen drei- und sechsschneidig
ab Ø 10 mm**

**Groove milling by circular interpolation with
three and six cutting edges starting at Ø 10 mm**

MINIMILL

Nut- und Formzirkularfräsen

groove milling by circular interpolation

Übersicht

summary



Allgemeine Beschreibung

general instructions

... 341



Frälerschaft mit innerer Kühlmittelzufuhr

milling shank with through coolant

Maße dimensions

Seite page

Typ ZH10	Frälerschaft Stahl	milling shank steel	D min. 10	... 342
Typ ZH10	Frälerschaft Hartmetall	milling shank carbide	D min. 10	... 343
Typ ZH14	Frälerschaft Stahl	milling shank steel	D min. 14	... 344
Typ ZH14	Frälerschaft Hartmetall	milling shank carbide	D min. 14	... 345
Typ ZH18	Frälerschaft Stahl	milling shank steel	D min. 18	... 346
Typ ZH18	Frälerschaft Hartmetall	milling shank carbide	D min. 18	... 347
Typ ZH22	Frälerschaft Stahl	milling shank steel	D min. 22	... 348
Typ ZH22	Frälerschaft Hartmetall	milling shank carbide	D min. 22	... 349
Typ ZH28	Frälerschaft Stahl	milling shank steel	D min. 25	... 350
Typ ZH28	Frälerschaft Hartmetall	milling shank carbide	D min. 25	... 351
Typ ZH28	Frälerschaft Schwermetall	milling shank heavy metal	D min. 28	... 352
Typ ZH33	Frälerschaft Hartmetall	milling shank carbide	D min. 28	... 353

MINIMILL

Nut- und Formzirkularfräsen

groove milling by circular interpolation

Übersicht

summary



Schneideinsatz Nutfräsen

inserts groove milling

Maße dimensions

Seite page

Typ Z10	Sicherungsringe DIN 471/472 und Nutfräsen allgemein	for circlips DIN 471/472, groove milling general use	D min. 10 t max. = 1.5	... 355
Typ Z12	Sicherungsringe DIN 471/472 und Nutfräsen allgemein	for circlips DIN 471/472, groove milling general use	D min. 12 t max. = 2.5	... 356
Typ Z612 / Z612.X	Nutfräsen allgemein	groove milling general use	D min. 12 t max. = 2	... 357
Typ Z14	Nutfräsen allgemein	groove milling general use	D min. 14 t max. = 2.5	... 358
Typ Z16	Nutfräsen allgemein	groove milling general use	D min. 16 t max. = 3.5	... 359
Typ Z616 / Z616.X	Nutfräsen allgemein	groove milling general use	D min. 16 t max. = 3.5	... 360
Typ Z18	Sicherungsringe DIN 471/472 und Nutfräsen allgemein	for circlips DIN 471/472, groove milling general use	D min. 18 t max. ≤ 3.5	... 361
Typ Z618	Sicherungsringe DIN 471/472	for circlips DIN 471/472	D min. 18 t max. = 4	... 363
Typ Z618 / Z618.X / Z620 / Z620.X	Nutfräsen allgemein	groove milling general use	D min. 18 / 20 t max. = 4 / 5	... 364
Typ Z22	Sicherungsringe DIN 471/472 und Nutfräsen allgemein	for circlips DIN 471/472, groove milling general use	D min. 22 t max. ≤ 4.5	... 365
Typ Z22	Sicherungsringe DIN 471/472 mit Nutaußenkantenfasung	for circlips DIN 471/472 with chamfer	D min. 22	... 367
Typ Z622 / Z622.X	Nutfräsen allgemein	groove milling general use	D min. 22 t max. = 4.5	... 368
Typ Z25	Nutfräsen allgemein	groove milling general use	D min. 25 t max. = 5.0	... 369
Typ Z625.X	Nutfräsen allgemein	groove milling general use	D min. 25 t max. = 5.0	... 370
Typ Z28	Nutfräsen allgemein	groove milling general use	D min. 28 t max. = 6.5	... 371
Typ Z28	Nutfräsen allgemein	groove milling general use	D min. 28.3 t max. = 9.3	... 372
Typ Z628 / Z628.X	Sicherungsringe DIN 471/472 und Nutfräsen allgemein	for circlips DIN 471/472, groove milling general use	D min. 28 t max. = 6.5	... 373

↳ ...



MINIMILL

Nut- und Formzirkularfräsen

groove milling by circular interpolation

Übersicht

summary

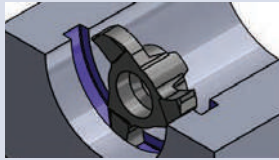

Schneideinsatz
Nutfräsen

inserts
groove milling

Maße
dimensions

Seite
page

... ↴

	Typ Z628	Nutfräsen allgemein	groove milling general use	D min. 28 t max. = 9.3	... 374
	Typ Z32	Nutfräsen allgemein	groove milling general use	D min. 32 t max. = 8.5	... 375
	Typ Z33	Nutfräsen allgemein	groove milling general use	D min. 33 / 33.9 t max. = 10 / 12	... 376
	Typ Z635 / Z635.X	Nutfräsen allgemein	groove milling general use	D min. 35 t max. = 10	... 377
	Typ Z637 / Z637.X / Z640	Nutfräsen allgemein	groove milling general use	D min. 37 / 40 t max. = 12 / 13.5	... 378
	Typ Z637 / Z640	Nutfräsen, Trennfräsen und Schlitzfräsen, b = 0.4 - 0.8 mm	for groove and keyway milling b = 0.4 - 0.8 mm	D min. 37 / 40 t max. = 12 / 13.5	... 379
	Typ Z12	Vollradius	full radius	D min. 12 t max. = 2.5	... 380
	Typ Z16	Vollradius	full radius	D min. 16 t max. = 3.5	... 381
	Typ Z18	Vollradius	full radius	D min. 18 t max. = 3.5	... 382
	Typ Z22	Vollradius	full radius	D min. 22 t max. = 4,5	... 383

MINIMILL

Nut- und Formzirkularfräsen

groove milling by circular interpolation

Übersicht

summary



**Schneideinsatz
Gewindefräsen**

**inserts
thread milling**

**Maße
dimensions**

**Seite
page**

Typ Z610	metrisches ISO-Gewinde, Teilprofil, innen	metric ISO-thread, partial profile, internal	ab / starting at M12 x 1.0	... 385
Typ Z10	metrisches ISO-Gewinde, Vollprofil, innen	metric ISO-thread, full profile, internal	ab / starting at M12 x 0.75	... 386
Typ Z12	metrisches ISO-Gewinde, Teilprofil, innen	metric ISO-thread partial profile, internal	ab / starting at M14 x 1.0	... 387
Typ Z614	metrisches ISO-Gewinde, Teilprofil, innen	metric ISO-thread, partial profile, internal	ab / starting at M16 x 1.0	... 388
Typ Z14	metrisches ISO-Gewinde, Vollprofil, innen	metric ISO-thread, full profile, internal	ab / starting at M16 x 1.0	... 389
Typ Z16	metrisches ISO-Gewinde, Teilprofil, innen	metric ISO-thread, partial profile, internal	ab / starting at M18 x 1.0	... 390
Typ Z18	metrisches ISO-Gewinde, Teilprofil, innen	metric ISO-thread, partial profile, internal	ab / starting at M22 x 1.0	... 391
Typ Z618	metrisches ISO-Gewinde, Teilprofil, innen	metric ISO-thread, partial profile, internal	ab / starting at M22 x 1.0	... 392
Typ Z18	metrisches ISO-Gewinde, Vollprofil, innen	metric ISO-thread, full profile, internal	ab / starting at M22 x 1.5	... 393
Typ Z618	metrisches ISO-Gewinde, Vollprofil, innen	metric ISO-thread, full profile, internal	ab / starting at M22 x 1,5	... 394
Typ Z22	metrisches ISO-Gewinde, Teilprofil, innen	metric ISO-thread, partial profile, internal	ab / starting at M27 x 1.0	... 395
Typ Z622	metrisches ISO-Gewinde, Teilprofil, innen	metric ISO-thread, partial profile, internal	ab / starting at M27 x 1.0	... 396
Typ Z22	metrisches ISO-Gewinde, Vollprofil, innen	metric ISO-thread, full profile, internal	ab / starting at M24 x 1.5	... 397
Typ Z622	metrisches ISO-Gewinde, Vollprofil, innen	metric ISO-thread, full profile, internal	ab / starting at M24 x 1.5	... 398
Typ Z28	metrisches ISO-Gewinde, Teilprofil, innen	metric ISO-thread, partial profile, internal	ab / starting at M33 x 1.0	... 399
Typ Z628	metrisches ISO-Gewinde, Teilprofil, innen	metric ISO-thread, partial profile, internal	ab / starting at M33 x 1.5	... 400
Typ Z622	metrisches ISO-Gewinde, Vollprofil, außen	metric ISO-thread, full profile, external	Steigung 1.5 - 4.0 pitch 1.5 - 4.0	... 401

↳ ...



MINIMILL

Nut- und Formzirkularfräsen

groove milling by circular interpolation

Übersicht

summary



**Schneideinsatz
Gewindefräsen**

**inserts
thread milling**

**Maße
dimensions**

**Seite
page**

... ↴

	Typ Z12	Whitworth- Gewinde Vollprofil, innen	Whitworth thread full profile, internal	ab / starting at G $\frac{3}{8}$ "	... 402
	Typ Z614	Whitworth- Gewinde Vollprofil, innen	Whitworth thread full profile, internal	ab / starting at G $\frac{3}{4}$ "	... 403
	Typ Z16	Whitworth- Gewinde Vollprofil, innen	Whitworth thread full profile, internal	ab / starting at G $\frac{5}{8}$ "	... 404
	Typ Z18	Whitworth- Gewinde Vollprofil, innen	Whitworth thread full profile, internal	ab / starting at G $\frac{3}{4}$ "	... 405
	Typ Z22	Whitworth- Gewinde Vollprofil, innen	Whitworth thread full profile, internal	ab / starting at G 1"	... 406
	Typ Z622	Whitworth- Gewinde Vollprofil, innen	Whitworth thread full profile, internal	ab / starting at G 1"	... 407



**Schneideinsatz
Fasen**

**inserts
chamfering**

**Maße
dimensions**

**Seite
page**

	Typ Z10 / Z12	Vorwärts- und Rückwärtsfasen	forward & backward chamfering	D min. 10 / 12	... 408
	Typ Z610	Vorwärts- und Rückwärtsfasen	forward & backward chamfering	D min. 10	... 409
	Typ Z614	Vorwärts- und Rückwärtsfasen	forward & backward chamfering	D min. 14	... 410
	Typ Z16	Vorwärts- und Rückwärtsfasen	forward & backward chamfering	D min. 16	... 411
	Typ Z18	Vorwärts- und Rückwärtsfasen	forward & backward chamfering	D min. 15	... 412
	Typ Z18	Vorwärts- und Rückwärtsfasen mit Radius	forward & backward chamfering with radius	D min. 18	... 413
	Typ Z22	Vorwärts- und Rückwärtsfasen	forward & backward chamfering	D min. 22	... 414
	Typ Z618 / Z622 / Z628	Vorwärts- und Rückwärtsfasen	forward & backward chamfering	D min. 15/18/ 22 /28	... 415

MINIMILL

Nut- und Formzirkularfräsen

groove milling by circular interpolation

Übersicht

summary

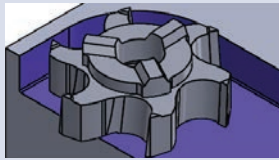

**Schneideinsatz
Stirn-/Planfräsen**

**inserts
face milling**

**Maße
dimensions**

**Seite
page**

Typ Z620 / Z628

Stirn- und Planfräsen

face milling

D min. 20 / 28

... 416



**Sets Minimill
Halter und Schneiden**

**sets Minimill
toolholder and inserts**

**Maße
dimensions**

**Seite
page**

SET-MINI-MILLZ12

Auswahl Z12

selection Z12

D min. 12

... 417

SET-MINI-MILLZ18

Auswahl Z18

selection Z18

D min. 18

... 417

SET-MINI-MILLZ22

Auswahl Z622 / Z22

selection Z622 / Z22

D min. 22

... 418

SET-MINI-MILLZ637

Auswahl Z637

selection Z637

D min. 37

... 418

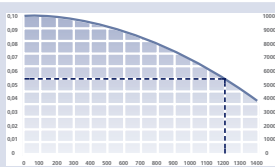

Technische Hinweise

Technical Instructions

**Seite
page**

Grundsätzliche Informationen zum Gewindefräsen

basic informations about thread milling

... 420

Hartmetallsorten und Beschichtungen

Carbide grades and coatings

...423

Ermittlung der Schnittdaten

evaluation of the cutting data

...425

Schnittdaten

cutting data

... 427

MINIMILL

Nut- und Formzirkularfräsen

groove milling by circular interpolation

Allgemeine Beschreibung

general instruction

Die austauschbaren drei- und sechsschneidigen HM-Schneiden verfügen über die bewährte Dreirippenverzahnung, welche einen bestmöglichen Rundlauf garantieren. Die große Auswahl an Standard-Schneideinsätzen sind, ebenso wie die Fräterschäfte, in Stahl und Hartmetall, ab Lager lieferbar.

The indexible carbide inserts are clamped with the proven interface. All inserts and milling shanks are available on stock.

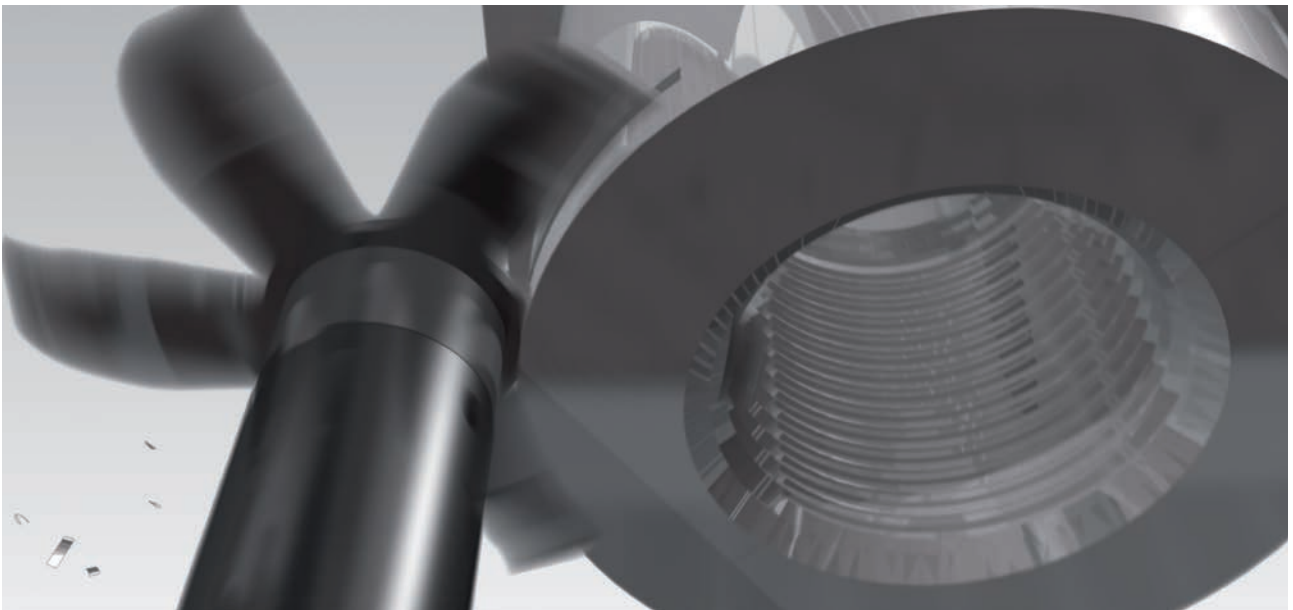
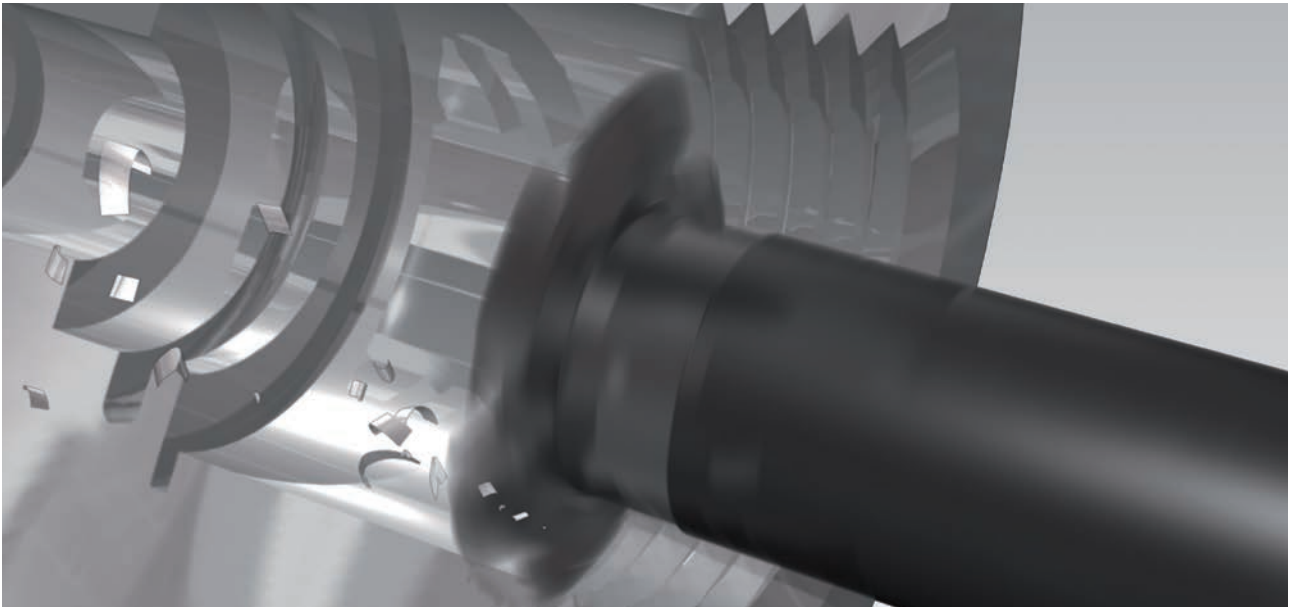

MINIMILL

Nut- und Formzirkularfräsen

groove milling by circular interpolation

Typ ZH10

Fräseschaft Stahl

milling shank steel

D min. 10 mm

D min. 10 mm

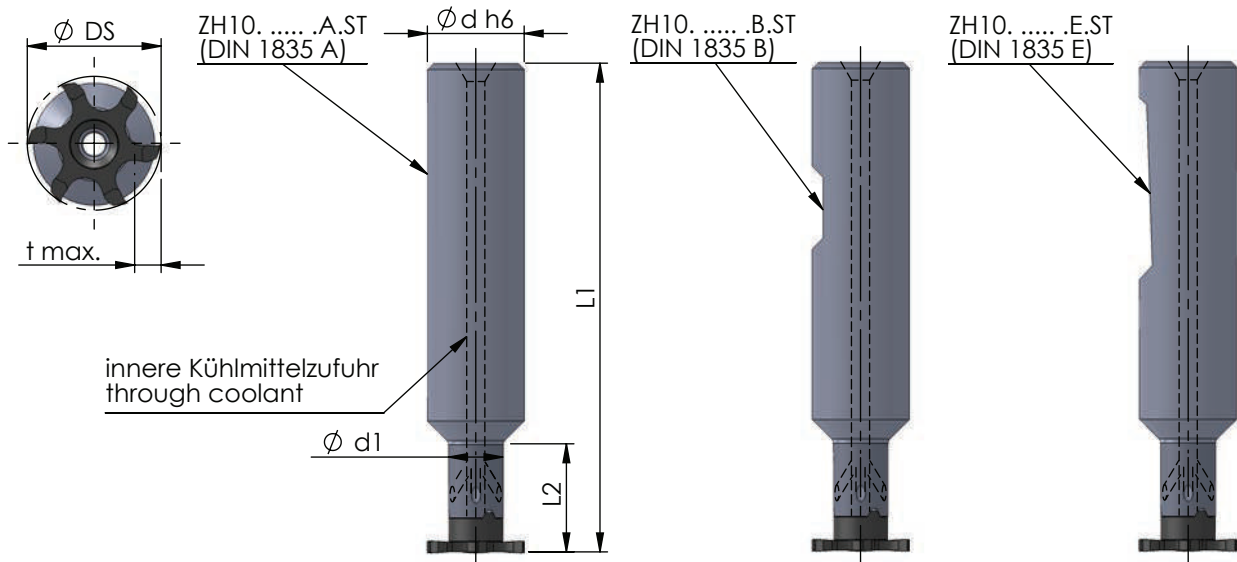

Abmessungen und Beschreibungen gelten für alle Varianten

dimensions and descriptions are valid for all versions

Abmessungen in mm

dimensions in mm



Bestellnummer part number					Typ: t max./ Schneidkreis-Ø DS	Spannschraube screw	Schraubenschlüssel wrench	Anzugs- drehmoment torque	für Schneideinsatz for insert
	Ø d h6	d1	L1	L2					
ZH10.1006.15.A.ST	10	6	60	15	Z10: 1.5 / 9.7 Z12: 2.5 / 11.7 Z612: 2 / 11.7	M2.6-MM	T 8F	2.0 Nm	Z10... Z12... Z610... Z612...
ZH10.1606.12.A.ST / ...B.ST / ...E.ST	16	6	80	12					

Bestellbeispiel:
ZH10.1606.12.A.ST

order-example:
ZH10.1606.12.A.ST



MINIMILL

Nut- und Formzirkularfräsen

groove milling by circular interpolation

Typ ZH10

Frälerschaft Hartmetall

D min. 10 mm

milling shank carbide

D min. 10 mm

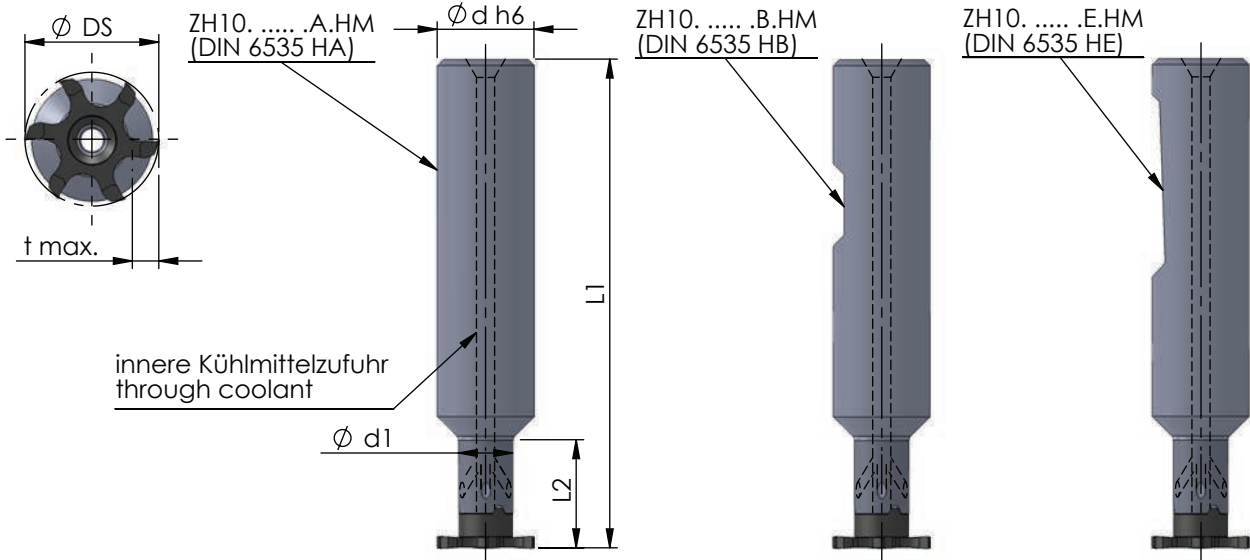

Abmessungen und Beschreibungen gelten für alle Varianten

dimensions and descriptions are valid for all versions

Abmessungen in mm

dimensions in mm

Bestellnummer part number	Ø d h6	Ø d (inch)	Ø d1	L1	L2	Typ: t max./ Schneidkreis-Ø DS	Spannschraube screw	Schraubenschlüssel wrench	Anzugs- drehmoment torque	für Schneideinsatz for insert
neu ZH10.1206.21.A.HM /...B.HM /...E.HM	12	6	80	21						
ZH10.U1206.21.A.HM /...B.HM	12.7	1/2"	6	80	21					
neu ZH10.1206.30.A.HM /...B.HM /...E.HM	12	6	90	30						
ZH10.U1206.30.A.HM /...B.HM	12.7	1/2"	6	90	30					
neu ZH10.1206.42.A.HM /...B.HM /...E.HM	12	6	100	42	Z10: 1.5 / 9.7 Z12: 2.5 / 11.7 Z612: 2 / 11.7	M2.6-MM	T 8F	2.0 Nm	Z10... Z12... Z610... Z612...	
ZH10.U1206.42.A.HM /...B.HM	12.7	1/2"	6	100	42					
neu ZH10.1207.30.A.HM /...B.HM /...E.HM	12	7.3	90	30	t max. reduziert					
ZH10.U1207.30.A.HM /...B.HM	12.7	1/2"	7.3	90	30	t max. reduziert				
ZH10.1607.25.A.HM /...B.HM /...E.HM	16	7.3	100	25	t max. reduced					

Hinweis:
Hartmetall-Frälerschäfte mit beschädigter
Schneidplattenaufnahme können durch unseren
Reparaturservice instand gesetzt werden.

note:
carbide-toolholder with damaged seating can be
repaired by Dümmel.

Bestellbeispiel:
ZH10.1607.25.A.HM

order-example:
ZH10.1607.25.A.HM

MINIMILL

Nut- und Formzirkularfräsen

groove milling by circular interpolation

Typ ZH14

Fräferschaft Stahl

milling shank steel

D min. 14 mm

D min. 14 mm

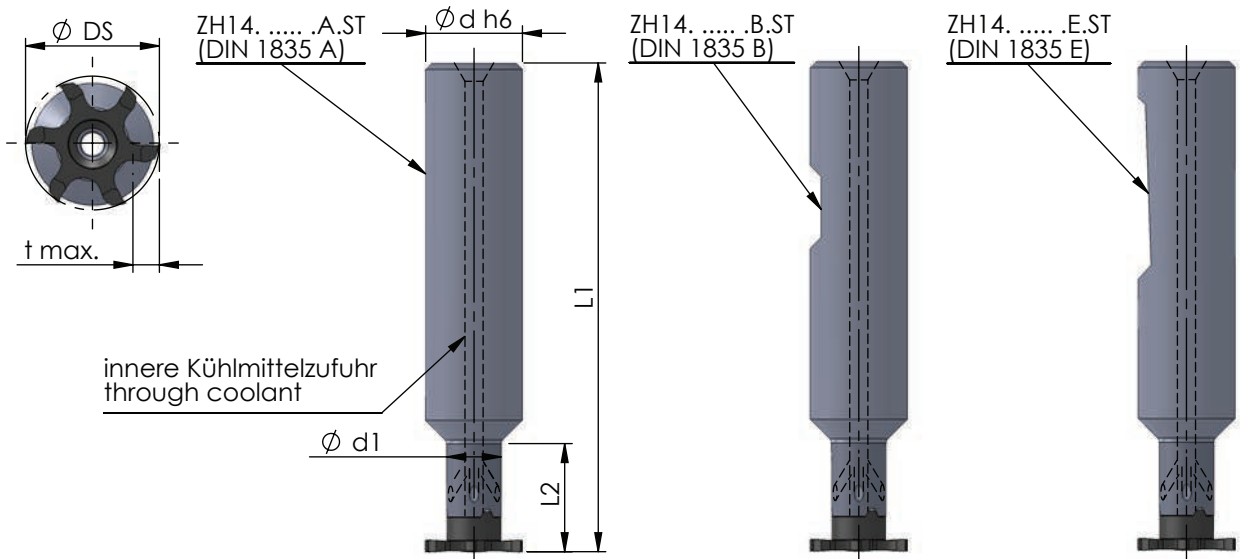

Abmessungen und Beschreibungen gelten für alle Varianten

dimensions and descriptions are valid for all versions

Abmessungen in mm

dimensions in mm

Bestellnummer part number	$\varnothing d h6$	d1	L1	L2	Typ: t max./ Schneidkreis- $\varnothing DS$	Spannschraube screw	Schraubenschlüssel wrench	Anzugs- drehmoment torque	für Schneideinsatz for insert
ZH14.1008.17.A.ST	10	8	60	17	Z14: 2.5 / 13.7	M3.5-MM	T 10F	3.5 Nm	Z14...
ZH14.1308.25.A.ST	13	8	70	25	Z16: 3.5 / 15.7				Z16...
ZH14.1608.16.A.ST /...B.ST /...E.ST	16	8	80	16	Z616: 2.5 / 15.7				Z614... Z616...

Bestellbeispiel:
ZH14.1608.16.A.ST

order-example:
ZH14.1608.16.A.ST



MINIMILL

Nut- und Formzirkularfräsen

groove milling by circular interpolation

Typ ZH14

Frälerschaft Hartmetall

D min. 14 mm

milling shank carbide

D min. 14 mm

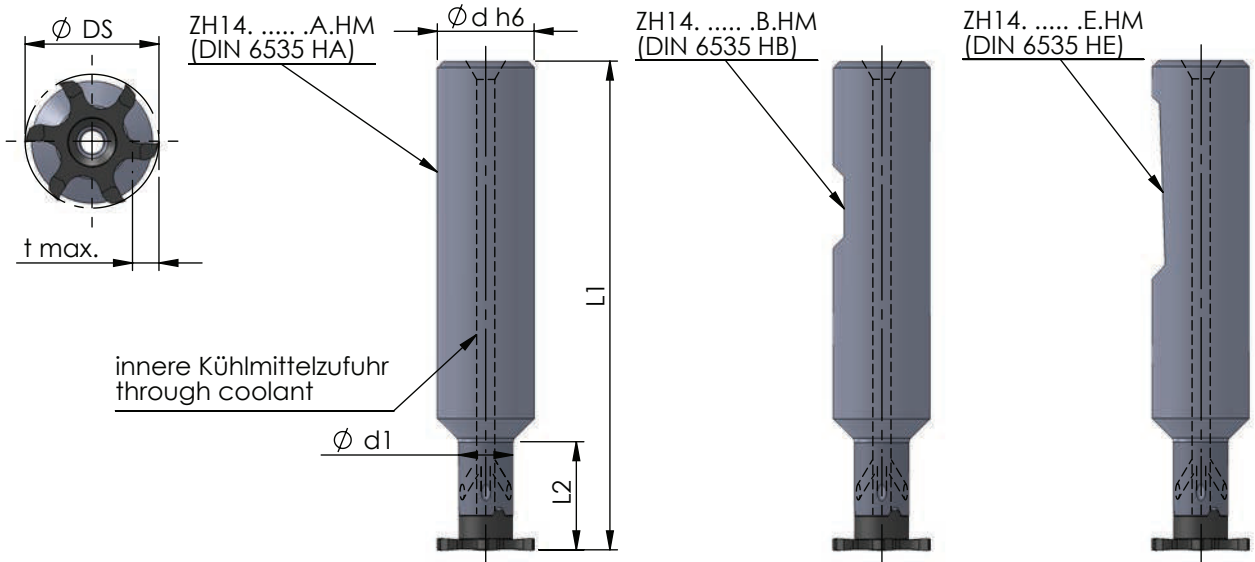

Abmessungen und Beschreibungen gelten für alle Varianten

dimensions and descriptions are valid for all versions

Abmessungen in mm

dimensions in mm

Bestellnummer part number	Ø d h6	Ø d (inch)	Ø d1	L1	L2	Typ: t max./ Schneidkreis-Ø DS	Spannschraube screw	Schraubenschlüssel wrench	Anzugs- drehmoment torque	für Schneideinsatz for insert
neu ZH14.1208.29.A.HM /...B.HM /...E.HM	12	8	95	29						
ZH14.U1208.29.A.HM /...B.HM	12.7	1/2"	8	95	29					
neu ZH14.1208.42.A.HM /...B.HM /...E.HM	12	8	110	42						
ZH14.U1208.42.A.HM /...B.HM	12.7	1/2"	8	110	42					
neu ZH14.1208.56.A.HM /...B.HM /...E.HM	12	8	120	56		Z14: 2.5 / 13.7 Z16: 3.5 / 15.7 Z616: 2.5 / 15.7	M3.5-MM	T 10F	3.5 Nm	Z14... Z16... Z614... Z616...
ZH14.U1208.56.A.HM /...B.HM	12.7	1/2"	8	120	56					
neu ZH14.1209.42.A.HM /...B.HM /...E.HM	12	9.5	110	42		t max. reduziert				
ZH14.U1209.42.A.HM /...B.HM	12.7	1/2"	9.5	110	42	t max. reduziert				
ZH14.1609.33.A.HM /...B.HM /...E.HM	16	9.5	110	33		t max. reduced				

Hinweis:
Hartmetall-Frälerschäfte mit beschädigter
Schneidplattenaufnahme können durch unseren
Reparaturservice instand gesetzt werden.

note:
carbide-toolholder with damaged seating can be
repaired by Dümmel.

Bestellbeispiel:
ZH14.1609.33.A.HM

order-example:
ZH14.1609.33.A.HM

MINIMILL

Nut- und Formzirkularfräsen

groove milling by circular interpolation

Typ ZH18

Fräferschaft Stahl

milling shank steel

D min. 18 mm

D min. 18 mm

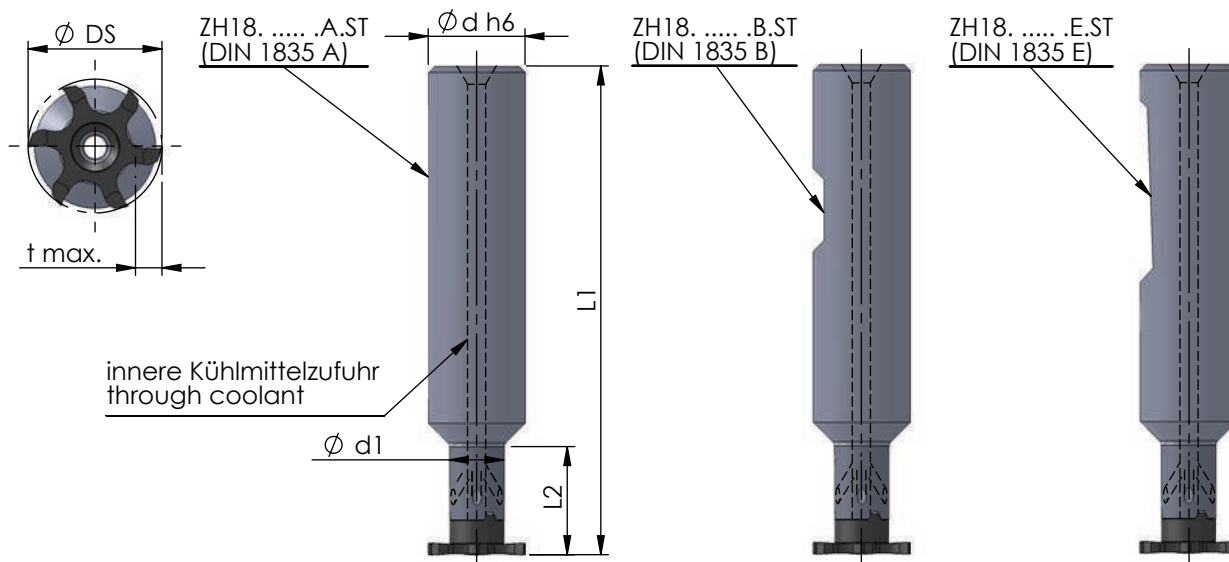

Abmessungen und Beschreibungen gelten für alle Varianten

dimensions and descriptions are valid for all versions

Abmessungen in mm

dimensions in mm

Bestellnummer part number					Typ: t max./ Schneidkreis- $\varnothing DS$	Spannschraube screw	Schraubenschlüssel wrench	Anzugs- drehmoment torque	für Schneideinsatz for insert
	$\varnothing d_{h6}$	d1	L1	L2					
ZH18.1009.17.A.ST	10	9	60	17	Z18: 3.5 / 17.7 Z618: 4 / 17.7 Z620: 5 / 19.7	M4-MM	T 15F	4.5 Nm	Z18... Z618... Z620...
ZH18.1309.25.A.ST	13	9	70	25					
ZH18.1609.18.A.ST /...B.ST /...E.ST	16	9	80	18					

Bestellbeispiel:
ZH18.1609.18.A.ST

order-example:
ZH18.1609.18.A.ST



MINIMILL

Nut- und Formzirkularfräsen

groove milling by circular interpolation

Typ ZH18

Frälerschaft Hartmetall

D min. 18 mm

milling shank carbide

D min. 18 mm

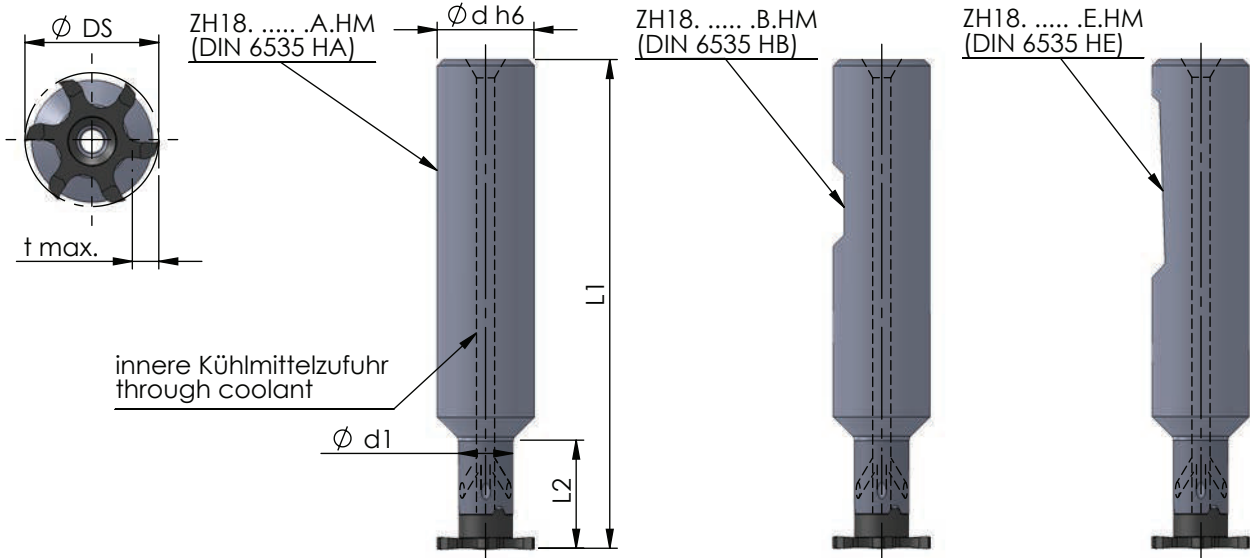

Abmessungen und Beschreibungen gelten für alle Varianten

dimensions and descriptions are valid for all versions

Abmessungen in mm

dimensions in mm

Bestellnummer part number	$\varnothing d_{h6}$	$\varnothing d$ (inch)	$\varnothing d_1$	L1	L2	Typ: t max./ Schneidkreis- $\varnothing DS$	Spannschraube screw	Schraubenschlüssel wrench	Anzugs- drehmoment torque	für Schneideinsatz for insert
neu ZH18.1209.32.A.HM /...B.HM /...E.HM	12		9	100	32	Z18: 3.5 / 17.7 Z618: 4 / 17.7 Z620: 5 / 19.7	M4-MM	T 15F	4.5 Nm	Z18... Z618... Z620...
ZH18.U1209.32.A.HM /...B.HM	12.7	1/2"	9	100	32					
neu ZH18.1209.45.A.HM /...B.HM /...E.HM	12		9	100	45					
ZH18.U1209.45.A.HM /...B.HM	12.7	1/2"	9	100	45					
neu ZH18.1209.64.A.HM /...B.HM /...E.HM	12		9	120	64					
ZH18.U1209.64.A.HM /...B.HM	12.7	1/2"	9	120	64					
neu ZH18.U1509.45.A.HM /...B.HM	15.875	5/8"	9	110	45					
ZH18.1609.25.A.HM /...B.HM /...E.HM	16		9	93	25					
ZH18.1609.32.A.HM /...B.HM /...E.HM	16		9	100	32					
ZH18.1609.45.A.HM /...B.HM /...E.HM	16		9	110	45					
ZH18.1609.64.A.HM /...B.HM /...E.HM	16		9	130	64					
ZH18.1613.64.A.HM /...B.HM /...E.HM	16		13	110	64					
ZH18.1613.66.A.HM /...B.HM /...E.HM	16		13	130	66	t max. reduced				

Hinweis:
Hartmetall-Frälerschäfte mit beschädigter Schneidplattenaufnahme können durch unseren Reparaturservice instand gesetzt werden.

note:
carbide-toolholder with damaged seating can be repaired by Dümmel.

Bestellbeispiel:
ZH18.1613.66.A.HM

order-example:
ZH18.1613.66.A.HM

MINIMILL

Nut- und Formzirkularfräsen

groove milling by circular interpolation

Typ ZH22

Frälerschaft Stahl

milling shank steel

D min. 22 mm

D min. 22 mm

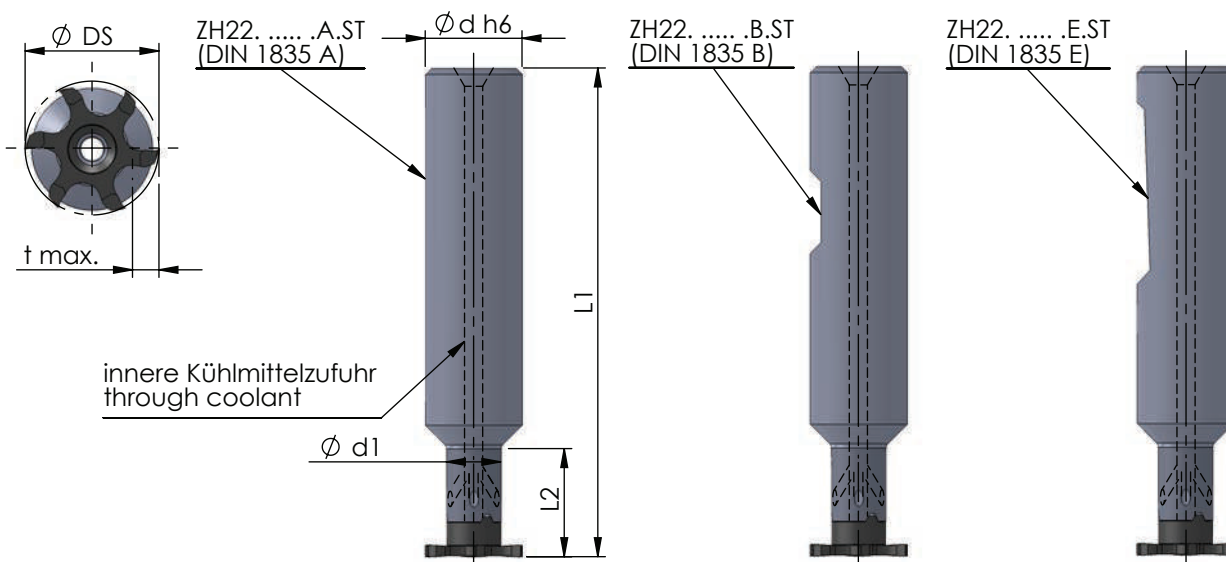

Abmessungen und Beschreibungen gelten für alle Varianten

dimensions and descriptions are valid for all versions

Abmessungen in mm

dimensions in mm

Bestellnummer part number	$\varnothing d h6$	$d1$	$L1$	$L2$	Typ: $t \text{ max.}/$ Schneidkreis- $\varnothing DS$	Spannschraube screw	Schraubenschlüssel wrench	Anzugs- drehmoment torque	für Schneideinsatz for insert
ZH22.1011.10.A.ST	10	11.3	60	10.7	Z22: 4.5 / 21.7 Z622: 4.5 / 21.7 Z33: 10 / 32.7 Z33: 12 / 32.7 Z637: 12 / 36.7 Z640: 13.5 / 39.7	M5-MM	T 20F	7.0 Nm	Z22...
ZH22.1311.25.A.ST	13	11.3	70	25.7					Z622...
ZH22.1612.24.A.ST /...B.ST /...E.ST	16	12	80	24					Z33...

Bestellbeispiel:
ZH22.1612.24.A.ST

order-example:
ZH22.1612.24.A.ST



MINIMILL

Nut- und Formzirkularfräsen

groove milling by circular interpolation

Typ ZH22

Frälerschaft Hartmetall

D min. 22 mm

milling shank carbide

D min. 22 mm

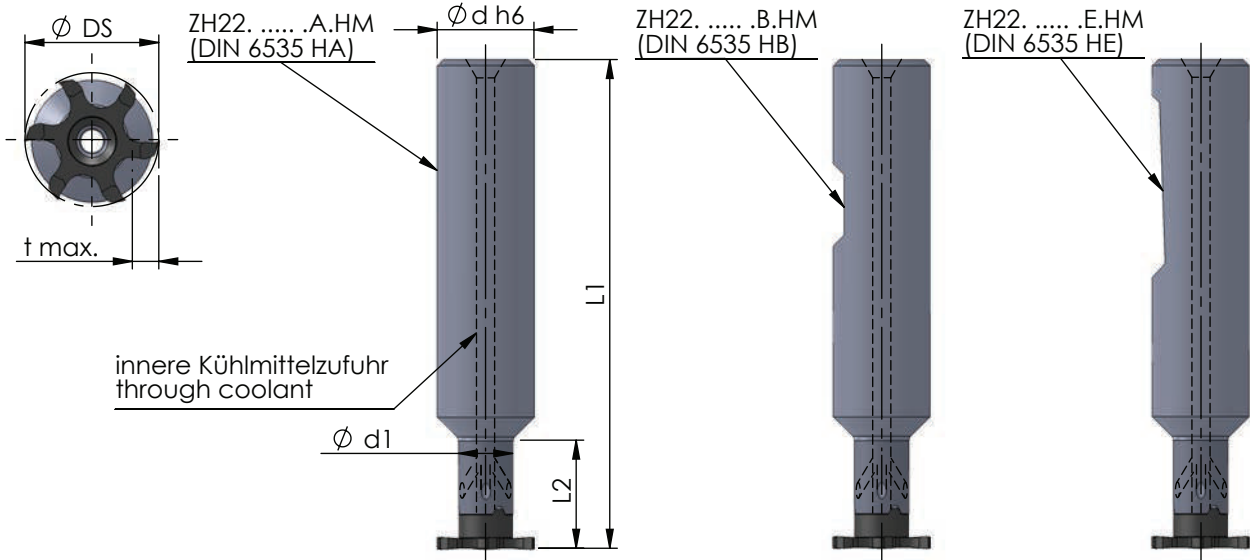

Abmessungen und Beschreibungen gelten für alle Varianten

dimensions and descriptions are valid for all versions

Abmessungen in mm

dimensions in mm

Bestellnummer part number	Ø d h6	Ø d (inch)	Ø d1	L1	L2	Typ: t max./ Schneidkreis-Ø DS	Spannschraube screw	Schraubenschlüssel wrench	Anzugs- drehmoment torque	für Schneideinsatz for insert	
ZH22.1212.42.A.HM /...B.HM /...E.HM	12	-	-	100	42	Z22: 4.5 / 21.7 Z622: 4.5 / 21.7 Z33: 10 / 32.7 Z33: 12 / 32.7 Z637: 12 / 36.7 Z640: 13.5 / 39.7	M5-MM	T 20F	7.0 Nm	Z22... Z622... Z33... Z637... Z640...	
neu ZH22.U1212.42.A.HM /...B.HM	12.7	1/2"	-	100	42						
ZH22.1212.60.A.HM /...B.HM /...E.HM	12	-	-	130	60						
neu ZH22.U1212.60.A.HM /...B.HM	12.7	1/2"	-	130	60						
neu ZH22.U1511.30.A.HM /...B.HM	15.875	5/8"	11.5	90	30						
neu ZH22.U1512.42.A.HM /...B.HM	15.875	5/8"	12	100	42						
neu ZH22.U1512.60.A.HM /...B.HM	15.875	5/8"	12	130	60						
neu ZH22.U1512.85.A.HM /...B.HM	15.875	5/8"	12	160	85						
ZH22.1611.30.A.HM /...B.HM /...E.HM	16	-	11.5	90	30						
ZH22.1612.42.A.HM /...B.HM /...E.HM	16	-	12	100	42						
ZH22.1612.60.A.HM /...B.HM /...E.HM	16	-	12	130	60						
ZH22.1612.85.A.HM /...B.HM /...E.HM	16	-	12	160	85						
ZH22.2016.45.A.HM /...B.HM /...E.HM	20	-	16	110	45						t max. reduziert
ZH22.2016.65.A.HM /...B.HM /...E.HM	20	-	16	130	65						t max. reduced

Hinweis:
Hartmetall-Frälerschäfte mit beschädigter
Schneidplattenaufnahme können durch unseren
Reparaturservice instand gesetzt werden.

note:
carbide-toolholder with damaged seating can be
repaired by Dümmel.

Bestellbeispiel:
ZH22.2016.65.A.HM

order-example:
ZH22.2016.65.A.HM

MINIMILL

Nut- und Formzirkularfräsen

groove milling by circular interpolation

Typ ZH28

Fräferschaft Stahl

milling shank steel

D min. 25 mm

D min. 25 mm

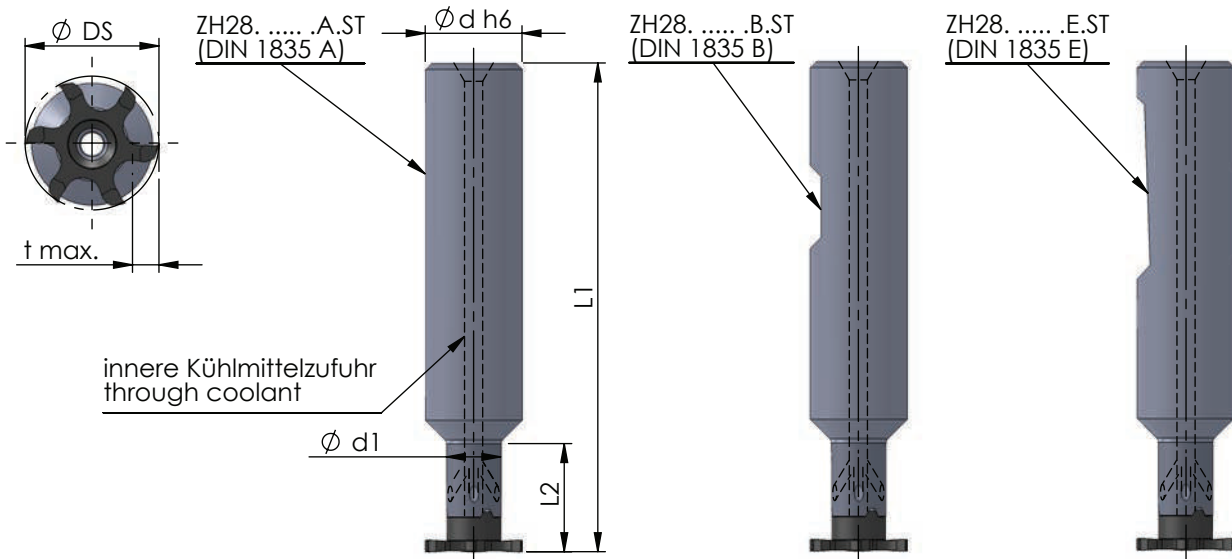

Abmessungen und Beschreibungen gelten für alle Varianten

dimensions and descriptions are valid for all versions

Abmessungen in mm

dimensions in mm

Bestellnummer part number	$\varnothing d h6$	d1	L1	L2	Typ: t max./ Schneidkreis- $\varnothing DS$	Spannschraube screw	Schraubenschlüssel wrench	Anzugs- drehmoment torque	für Schneideinsatz for insert
ZH28.1314.10.A.ST	13	14	70	10.7	Z25: 5 / 24.8 Z28: 6.5 / 27.7 Z628: 6.5 / 27.7 Z32: 8.5 / 31.7 Z635: 10 / 34.7	M5-MM	T 20F	7.0 Nm	Z25... Z28... Z628... Z32... Z635...
ZH28.2014.35.A.ST / ...B.ST	20	14	100	35.7					

Bestellbeispiel:
ZH28.2014.35.A.ST

order-example:
ZH28.2014.35.A.ST



MINIMILL

Nut- und Formzirkularfräsen

groove milling by circular interpolation

Typ ZH28

Fräseschaft Hartmetall

D min. 25 mm

milling shank carbide

D min. 25 mm

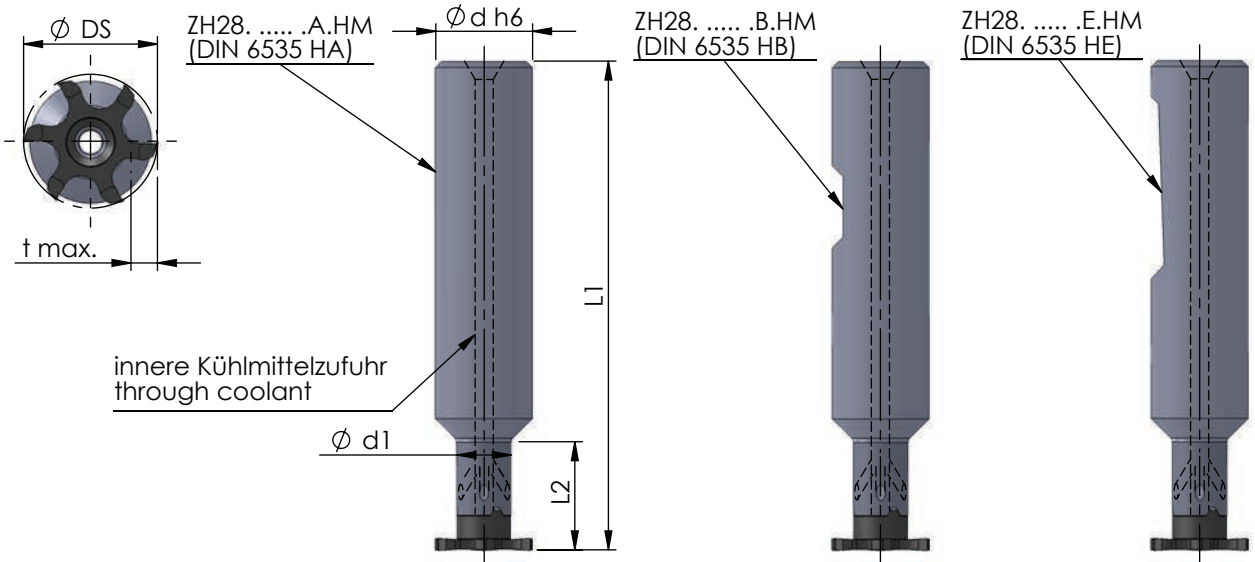

Abmessungen und Beschreibungen gelten für alle Varianten

dimensions and descriptions are valid for all versions

Abmessungen in mm

dimensions in mm

Bestellnummer part number	$\varnothing d h6$	$\varnothing d$ (inch)	$\varnothing d1$	L1	L2	Typ: t max./ Schneidkreis- $\varnothing DS$	Spannschraube screw	Schraubenschlüssel wrench	Anzugs- drehmoment torque	für Schneideinsatz for insert
neu ZH28.U1514.42.A.HM /...B.HM	15.875	5/8"	14.3	100	42	Z25: 5 / 24.8 Z28: 6.5 / 27.7 Z628: 6.5 / 27.7 Z32: 8.5 / 31.7 Z635: 10 / 34.7	M5-MM	T 20F	7.0 Nm	Z25... Z28... Z628... Z32... Z635...
neu ZH28.U1514.60.A.HM /...B.HM	15.875	5/8"	14.3	130	60					
neu ZH28.U1514.85.A.HM /...B.HM	15.875	5/8"	14.3	160	85					
ZH28.1614.42.A.HM /...B.HM /...E.HM	16		14.3	100	42					
ZH28.1614.60.A.HM /...B.HM /...E.HM	16		14.3	130	60					
ZH28.1614.85.A.HM /...B.HM /...E.HM	16		14.3	160	85					
ZH28.2013.35.A.HM /...B.HM /...E.HM	20		13.5	104	35					
ZH28.2014.85.A.HM /...B.HM /...E.HM	20		14.3	160	85					

Hinweis:
Hartmetall-Fräseschäfte mit beschädigter
Schneidplattenaufnahme können durch unseren
Reparaturservice instand gesetzt werden.

note:
carbide-toolholder with damaged seating can be
repaired by Dümmel.

Bestellbeispiel:
ZH28.2014.85.A.HM

order-example:
ZH28.2014.85.A.HM

MINIMILL

Nut- und Formzirkularfräsen

groove milling by circular interpolation

Typ ZH28

Frälerschaft Schwermetall

milling shank heavy metal

D min. 28 mm

D min. 28 mm

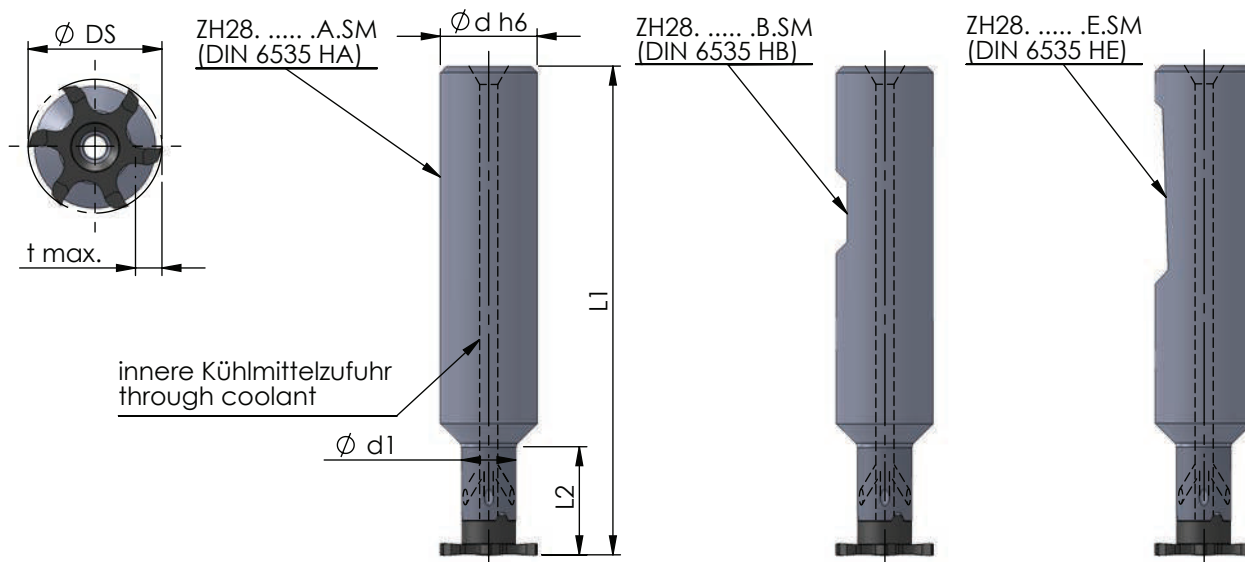

Abmessungen und Beschreibungen gelten für alle Varianten

dimensions and descriptions are valid for all versions

Abmessungen in mm

dimensions in mm

Bestellnummer part number	$\varnothing d_{h6}$	d1 *	L1	L2	Typ: t max./ * Schneidkreis- $\varnothing DS$	Spannschraube screw	Schraubenschlüssel wrench	Anzugs- drehmoment torque	für Schneideinsatz for insert
ZH28.2020.35.A.SM /...B.SM /...E.SM	20	20	145	-					
ZH28.2015.30.A.SM /...B.SM /...E.SM	20	15	160	30					
ZH28.2020.90.A.SM /...B.SM /...E.SM	20	20	200	-	Z28... Z628... Z32... Z635...				

* Achtung:
Durch die extrastabile Ausführung ist das t max. reduziert.

* attention:
The measure t max. is reduced by the extra-stable implementation.

Bestellbeispiel:
ZH28.2020.90.A.SM

order-example:
ZH28.2020.90.A.SM

MINIMILL

Nut- und Formzirkularfräsen

groove milling by circular interpolation

Typ ZH33

Frälerschaft Hartmetall

D min. 28 mm

milling shank carbide

D min. 28 mm

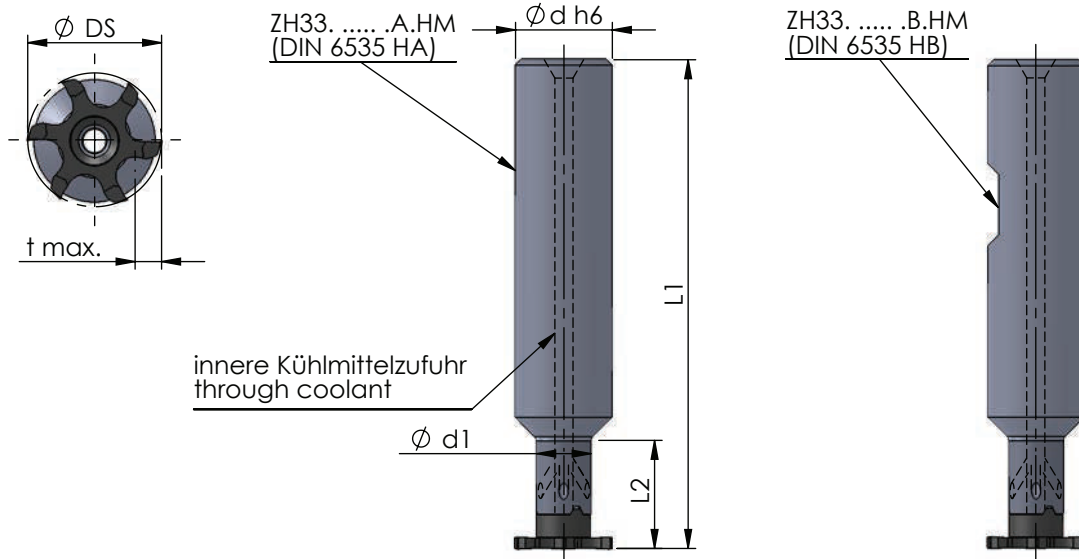

Abmessungen und Beschreibungen gelten für alle Varianten

dimensions and descriptions are valid for all versions

Abmessungen in mm

dimensions in mm

Bestellnummer part number	$\varnothing d h6$	d1	L1	L2	Typ: t max./ Schneidkreis- $\varnothing DS$	Spannschraube screw	Schraubenschlüssel wrench	Anzugs- drehmoment torque	für Schneideinsatz for insert
ZH33.1209.32.A.HM / -	12	9	100	32	Z28: 9.3 / 28	M5-MM	T 20F	7.0 Nm	Z28. Z628.150.02.9 Z33.170.42.12
ZH33.1609.33.A.HM / ...B.HM	16	9	100	33	Z628.9 : 9.3 / 27.7 Z33.12 : 12 / 33.6				

Hinweis:
Hartmetall-Frälerschäfte mit beschädigter
Schneidplattenaufnahme können durch unseren
Reparaturservice instand gesetzt werden.

note:
carbide-toolholder with damaged seating can be
repaired by Dümmel.

Bestellbeispiel:
ZH33.1609.33.A.HM

order-example:
ZH33.1609.33.A.,HM

MINIMILL

Nut- und Formzirkularfräsen

groove milling by circular interpolation

Impressionen

impressions



MINIMILL

Nut- und Formzirkularfräsen

groove milling by circular interpolation

Typ Z10

Sicherungsringe DIN 471 / 472 und Nutfräsen allgemein

D min. 10 mm
t max. = 1.5

for circlip grooves DIN 471 / 472 and groove milling general use

D min. 10 mm
t max. = 1.5

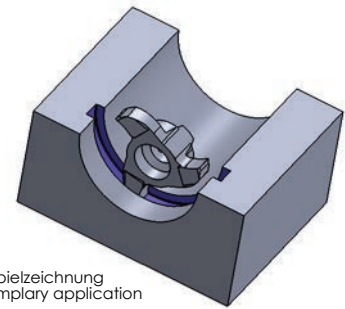
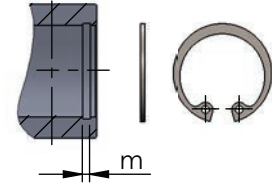
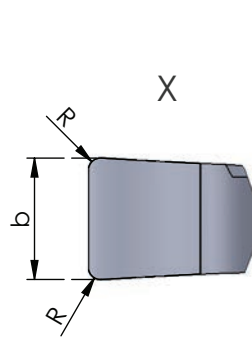
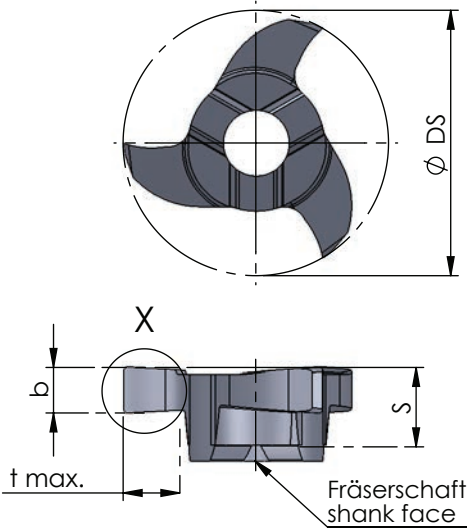

Beispielzeichnung
exemplary application

Abmessungen in mm

dimensions in mm

Bestellnummer part number	D min.	Nut-Maß m groove dim. m	DIN 471 / DIN 472	S	R	Ø DS	b +0.02 (* b -0.02)	t max.	Zähnezahl number of teeth	K10F	AL41F	P18C	für Fräseschaft for milling shank
Z10.0070.00	10	0.7	☉	3.4	-	9.7	0.74*	1.5	3	●			ZH10...
Z10.0080.00	10	0.8	☉	3.4	-	9.7	0.84*	1.5	3	●			
Z10.0090.00	10	0.9	☉	3.4	-	9.7	0.94*	1.5	3	●			
Z10.0100.00	10	-	-	3.4	0.1	9.7	1.00	1.5	3	●			
Z10.0110.00	10	1.1	☉	3.5	-	9.7	1.21*	1.5	3	●			
Z10.0130.00	10	1.3	☉	3.5	0.1	9.7	1.41*	1.5	3	●			
Z10.0150.00	10	-	-	3.5	0.2	9.7	1.50	1.5	3	●			
Z10.0160.00	10	1.6	☉	3.5	0.1	9.7	1.71*	1.5	3	●			
Z10.0200.00	10	-	-	3.5	0.2	9.7	2.00	1.5	3	●			
Z10.0250.00	10	-	-	3.5	0.2	9.7	2.50	1.5	3	●			

Weitere HM Sorten können Sie in der Sortenübersicht im Kapitel "Technische Hinweise" und der Preisliste finden.

Bestellbeispiel:
für Sorte AL41F:
Z10.0160.00/AL41F

More carbide grades you can find in the grades summary in the chapter "technical instructions" and in the price list.

order-example:
grade AL41F:
Z10.0160.00/AL41F

MINIMILL

Nut- und Formzirkularfräsen

groove milling by circular interpolation

Typ Z12

Sicherungsringe DIN 471 / 472 und Nutfräsen allgemein

D min. 12 mm
t max. = 2.5

for circlip grooves DIN 471 / 472 and groove milling general use

D min. 12 mm
t max. = 2.5

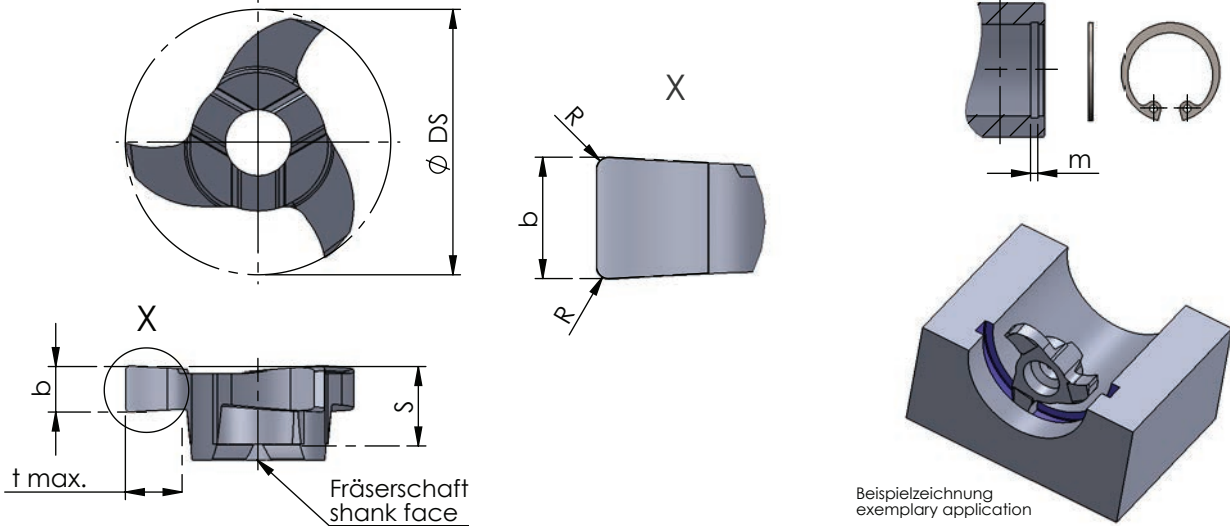

Abmessungen in mm

dimensions in mm

neu

Bestellnummer part number	D min.	Nut-Maß m groove dim. m DIN 471 / DIN 472	S	R	Ø DS	b +0.02 (* b -0.02)	b (inch)	t max.	Zähnezahl number of teeth	K10F	AL41F	P18C	für Fräseschaft for milling shank
Z12.0110.00	12	1.1	3.5	-	11.7	1.21*		2.5	3	●			ZH10...
Z12.0117.00	12	-	3.5	-	11.7	1.17	0.046"	2.5	3	●			
Z12.0130.00	12	1.3	3.5	0.1	11.7	1.41*		2.5	3	●			
Z12.0142.01	12	-	3.5	0.1	11.7	1.42	0.056"	2.5	3	●			
Z12.0150.02	12	-	3.5	0.2	11.7	1.50		2.5	3	●			
Z12.0157.02	12	-	3.5	0.2	11.7	1.57	0.062"	2.5	3	●			
Z12.0160.00	12	1.6	3.5	0.1	11.7	1.71*		2.5	3	●			
Z12.0198.02	12	-	3.5	0.2	11.7	1.98	0.078"	2.5	3	●			
Z12.0200.00	12	-	3.5	0.2	11.7	2.00		2.5	3	●			
Z12.0238.02	12	-	3.5	0.2	11.7	2.39	0.094"	2.5	3	●			
Z12.0250.00	12	-	3.5	0.2	11.7	2.50		2.5	3	●			
Z12.0300.00	12	-	3.5	0.2	11.7	3.00		2.5	3	●			

Weitere HM Sorten können Sie in der Sortenübersicht im Kapitel "Technische Hinweise" und der Preisliste finden.

Bestellbeispiel:
für Sorte AL41F:
Z12.0160.00/AL41F

More carbide grades you can find in the grades summary in the chapter "technical instructions" and in the price list.

order-example:
grade AL41F:
Z12.0160.00/AL41F

MINIMILL

Nut- und Formzirkularfräsen

groove milling by circular interpolation

Typ Z612 / Z612.X

Nutfräsen allgemein

for groove milling general use

D min. 12 mm
t max. = 2

D min. 12 mm
t max. = 2

Z612 geradverzahnt / spur-toothed

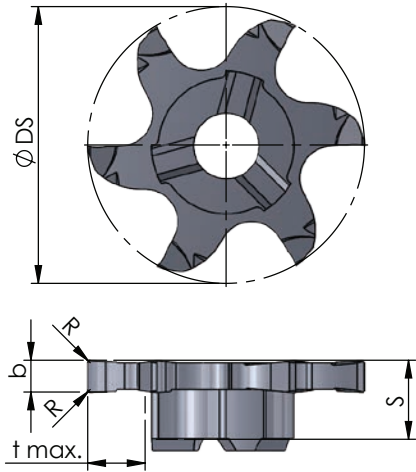

Z612.X kreuzverzahnt / staggered-toothed

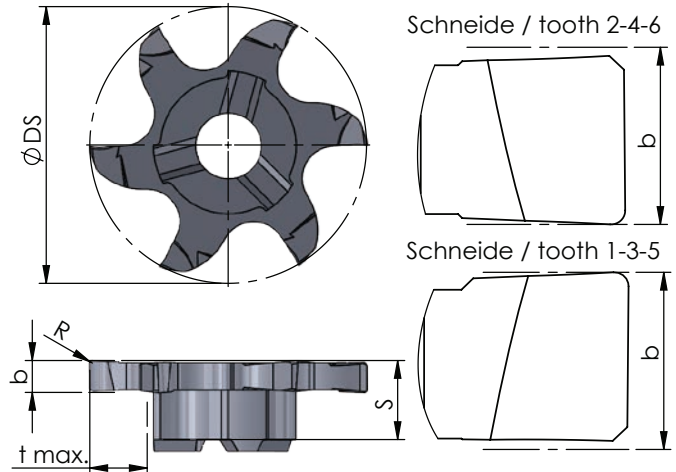

Abmessungen in mm

dimensions in mm

Bestellnummer part number	D min.	S	R	Ø DS	b +0.02	t max.	Zähnezahl number of teeth	Material			für Fräseschaft for milling shank
								K10F	AL41F	P18C	
Z612.0150.02	12	3.5	0.2	11.7	1.5	2.0	6	●			ZH10...
Z612.X150.02	12	3.5	0.2	11.7	1.5	2.0	6		●		
Z612.0200.02	12	3.5	0.2	11.7	2.0	2.0	6		●		
Z612.X200.02	12	3.5	0.2	11.7	2.0	2.0	6		●		

Weitere HM Sorten können Sie in der Sortenübersicht im Kapitel "Technische Hinweise" und der Preisliste finden.

Bestellbeispiel:
für Sorte AL41F:
Z612.0150.02/AL41F

More carbide grades you can find in the grades summary in the chapter "technical instructions" and in the price list.

order-example:
grade AL41F:
Z612.0150.02/AL41F

MINIMILL

Nut- und Formzirkularfräsen

groove milling by circular interpolation

Typ Z14

Nutfräsen allgemein

for groove milling general use

D min. 14 mm
t max. = 2.5

D min. 14 mm
t max. = 2.5

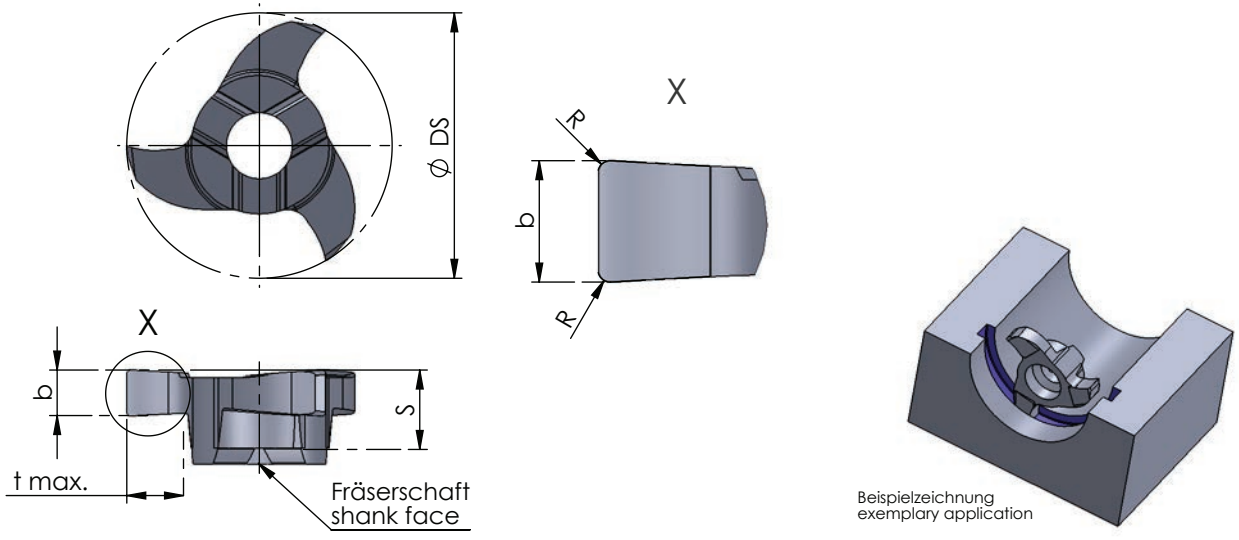

Abmessungen in mm

dimensions in mm

Bestellnummer part number	D min.	S	R	Ø DS	b +0.02	t max.	Zähnezahl number of teeth	Material			für Fräterschaft for milling shank
								K10F	AL41F	P18C	
Z14.0100.00	14	4.5	0.1	13.7	1.0	2.5	3	●			ZH14...
Z14.0150.00	14	4.5	0.2	13.7	1.5	2.5	3		●		
Z14.0200.02	14	4.5	0.2	13.7	2.0	2.5	3		●		
Z14.0250.02	14	4.5	0.2	13.7	2.5	2.5	3		●		

Weitere HM Sorten können Sie in der Sortenübersicht im Kapitel "Technische Hinweise" und der Preisliste finden.

Bestellbeispiel:
für Sorte AL41F:
Z14.0150.00/AL41F

More carbide grades you can find in the grades summary in the chapter "technical instructions" and in the price list.

order-example:
grade AL41F:
Z14.0150.00/AL41F

MINIMILL

Nut- und Formzirkularfräsen

groove milling by circular interpolation

Typ Z16

Nutfräsen allgemein

for groove milling general use

D min. 16 mm
t max. = 3.5

D min. 16 mm
t max. = 3.5

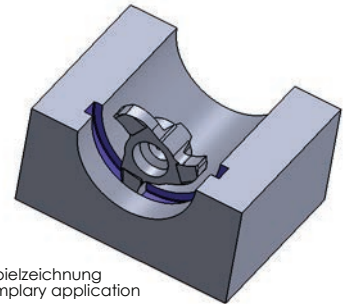
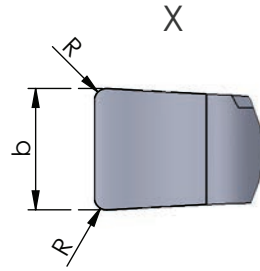
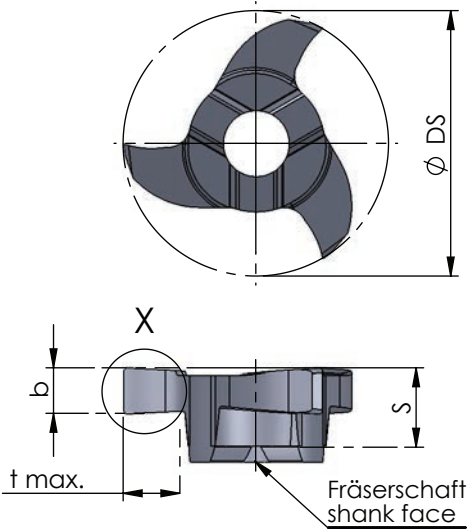

Beispielzeichnung
exemplary application

Abmessungen in mm

dimensions in mm

Bestellnummer part number	D min.	S	R	Ø DS	b +0.02	b (inch)	t max.	Zähnezahl number of teeth	K10F	AL41F	P18C	für Fräterschaft for milling shank
Z16.0117.00	16	4.5	-	15.7	1.17	0.046"	3.5	3	●			ZH14...
Z16.0150.00	16	4.5	0.2	15.7	1.5		3.5	3	●			
Z16.0157.02	16	4.5	0.2	15.7	1.57	0.062"	3.5	3	●			
Z16.0200.02	16	4.5	0.2	15.7	2.0		3.5	3	●			
Z16.0238.02	16	4.5	0.2	15.7	2.39	0.094"	3.5	3	●			
Z16.0250.02	16	4.5	0.2	15.7	2.5		3.5	3	●			
Z16.0318.02	16	4.5	0.2	15.7	3.18	0.125"	3.5	3	●			

Weitere HM Sorten können Sie in der Sortenübersicht im Kapitel "Technische Hinweise" und der Preisliste finden.

Bestellbeispiel:
für Sorte AL41F:
Z16.0150.00/AL41F

More carbide grades you can find in the grades summary in the chapter "technical instructions" and in the price list.

order-example:
grade AL41F:
Z16.0150.00/AL41F

MINIMILL

Nut- und Formzirkularfräsen

groove milling by circular interpolation

Typ Z616 / Z616.X

Nutfräsen allgemein

for groove milling general use

D min. 16 mm
t max. = 3.5

D min. 16 mm
t max. = 3.5

Z616 geradverzahnt / spur-toothed

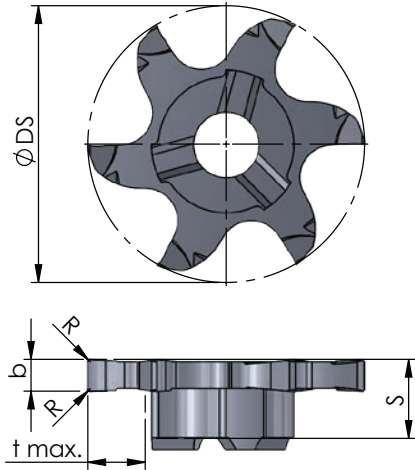

Z616.X kreuzverzahnt / staggered-toothed

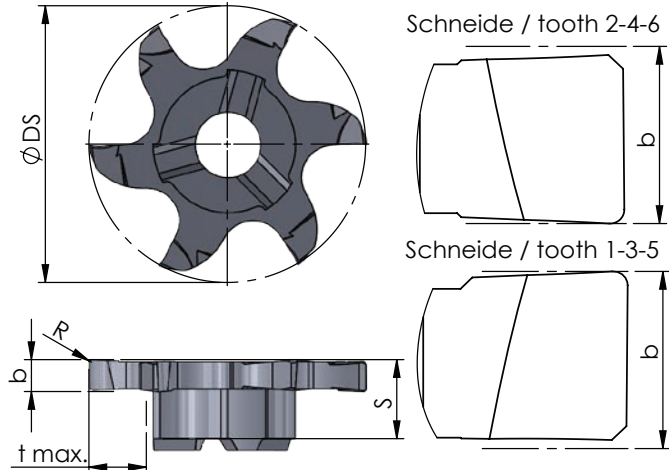

Abmessungen in mm

dimensions in mm



Bestellnummer part number	D min.	S	R	Ø DS	b +0.02	t max.	Zähnezahl number of teeth	Material			für Fräterschaft for milling shank
								K10F	AL41F	P18C	
Z616.X150.02	16	4.5	0.2	15.7	1.5	3.5	6	●			
Z616.0200.02	16	4.5	0.2	15.7	2.0	3.5	6		●		
Z616.X200.02	16	4.5	0.2	15.7	2.0	3.5	6		●		ZH14...
Z616.0250.02	16	4.5	0.2	15.7	2.5	3.5	6		●		
Z616.X250.02	16	4.5	0.2	15.7	2.5	3.5	6		●		

Weitere HM Sorten können Sie in der Sortenübersicht im Kapitel "Technische Hinweise" und der Preisliste finden.

Bestellbeispiel:
für Sorte AL41F:
Z616.X150.02/AL41F

More carbide grades you can find in the grades summary in the chapter "technical instructions" and in the price list.

order-example:
grade AL41F:
Z616.X150.02/AL41F

MINIMILL

Nut- und Formzirkularfräsen

groove milling by circular interpolation

Typ Z18

Sicherungsringe DIN 471 / 472
und Nutfräsen allgemein

D min. 18 mm
t max. ≤ 3.5

for circlip grooves DIN 471 / 472
and groove milling general use

D min. 18 mm
t max. ≤ 3.5

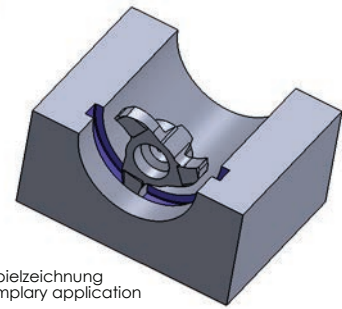
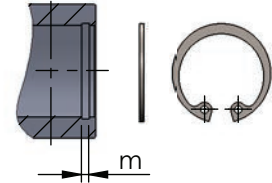
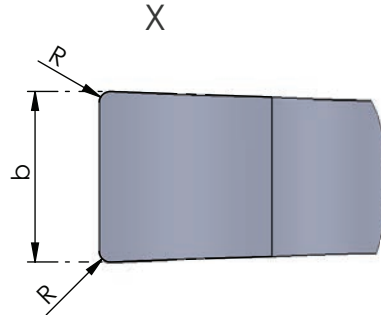
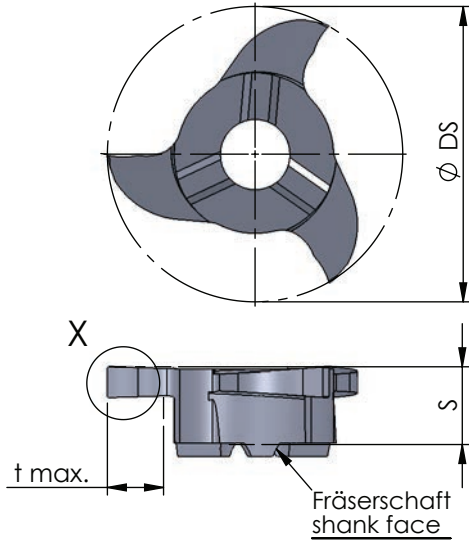

Abmessungen in mm

dimensions in mm

Bestellnummer part number	D min.	Nut-Maß m groove dim. m DIN 471 / DIN 472	S	R	Ø DS	b +0.02 (* b -0.02)	b (inch)	t max.	Zähnezahl number of teeth	K10F	AL41F	P18C	für Frälerschaft for milling shank
Z18.0070.00	18	0.7	5.6	-	17.7	0.74*		1.5	3	●			ZH18...
Z18.0080.00	18	0.8	5.6	-	17.7	0.84*		1.7	3	●			
Z18.0090.00	18	0.9	5.6	-	17.7	0.94*		1.9	3	●			
Z18.0110.00	18	1.1	5.8	-	17.7	1.21*		3.5	3	●			
Z18.0117.00	18	-	5.8	-	17.7	1.17	0.046"	3.5	3	●			
Z18.0130.00	18	1.3	5.8	0.1	17.7	1.41*		3.5	3	●			
Z18.0142.01	18	-	5.8	0.1	17.7	1.42	0.056"	3.5	3	●			
Z18.0150.00	18	-	5.8	0.2	17.7	1.50		3.5	3	●			
Z18.0157.02	18	-	5.8	0.2	17.7	1.57	0.062"	3.5	3	●			
Z18.0160.00	18	1.6	5.8	0.1	17.7	1.71*		3.5	3	●			
↳ ...													

Weitere HM Sorten können Sie in der Sortenübersicht im Kapitel "Technische Hinweise" und der Preisliste finden.

Bestellbeispiel:
für Sorte AL41F:
Z18.0110.00/AL41F

More carbide grades you can find in the grades summary in the chapter "technical instructions" and in the price list.

order-example:
grade AL41F:
Z18.0110.00/AL41F

MINIMILL

Nut- und Formzirkularfräsen

groove milling by circular interpolation

Typ Z18

Sicherungsringe DIN 471 / 472 und Nutfräsen allgemein

D min. 18 mm
t max. ≤ 3.5

for circlip grooves DIN 471 / 472 and groove milling general use

D min. 18 mm
t max. ≤ 3.5

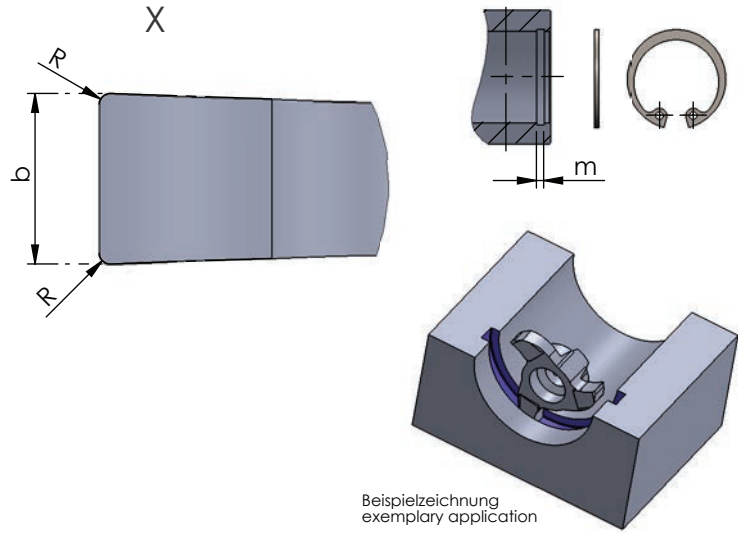
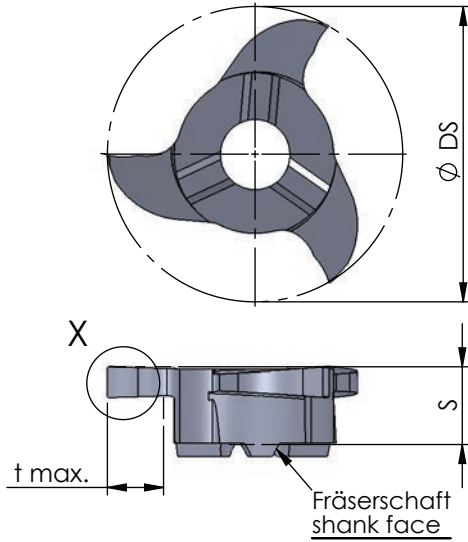

Abmessungen in mm

dimensions in mm

Bestellnummer part number	D min.	Nut-Maß m groove dim. m DIN 471 / DIN 472	S	R	Ø DS	b +0.02 (* b -0.02)	b (inch)	t max.	Zähnezahl number of teeth	K10F AL41F P18C	für Frälerschaft for milling shank
...											
Z18.0198.02	18	-	5.8	0.2	17.7	1.98	0.078"	3.5	3	●	ZH18...
Z18.0200.02	18	-	5.8	0.2	17.7	2.00		3.5	3	●	
Z18.0238.02	18	-	5.8	0.2	17.7	2.39	0.094"	3.5	3	●	
Z18.0250.02	18	-	5.8	0.2	17.7	2.50		3.5	3	●	
Z18.0300.02	18	-	5.8	0.2	17.7	3.00		3.5	3	●	
Z18.0318.02	18	-	5.8	0.2	17.7	3.18	0.125"	3.5	3	●	
Z18.0400.02	18	-	5.8	0.2	17.7	4.00		3.5	3	●	

Weitere HM Sorten können Sie in der Sortenübersicht im Kapitel "Technische Hinweise" und der Preisliste finden.

Bestellbeispiel:
für Sorte AL41F:
Z18.0198.02/AL41F

More carbide grades you can find in the grades summary in the chapter "technical instructions" and in the price list.

order-example:
grade AL41F:
Z18.0198.02/AL41F

MINIMILL

Nut- und Formzirkularfräsen

groove milling by circular interpolation

Typ Z618

Sicherungsringe DIN 471 / 472

D min. 18 mm
t max. = 4

for circlip grooves DIN 471 / 472

D min. 18 mm
t max. = 4

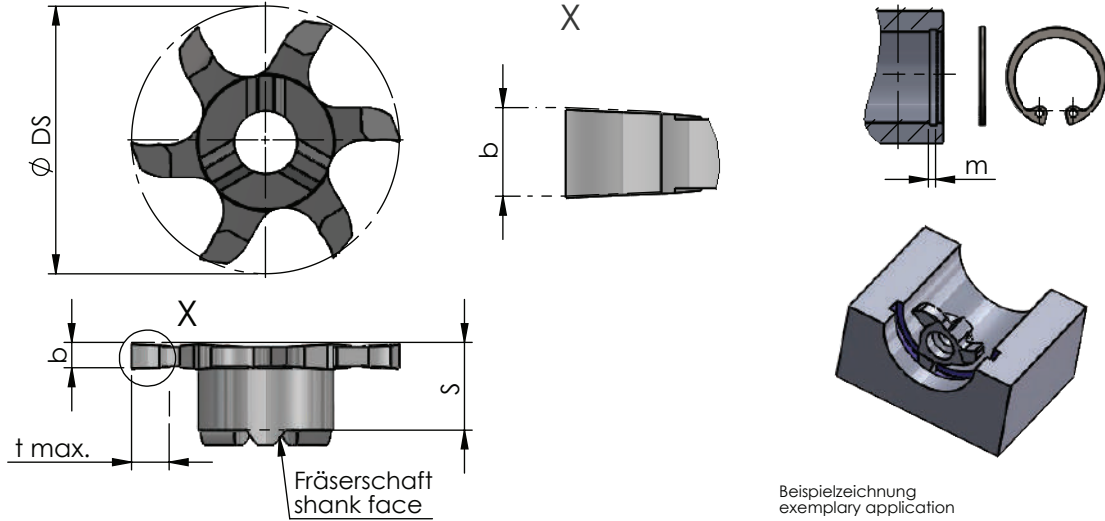

Beispielzeichnung
exemplary application

Abmessungen in mm

dimensions in mm

Bestellnummer part number	D min.	Nut-Maß m groove dim. m DIN 471 / DIN 472	S	R	$\varnothing DS$	b -0.02	t max.	Zähnezahl number of teeth				für Frärschaft for milling shank
									K10F	AL41F	P18C	
Z618.0110.00	18	1.1	5.8	-	17.7	1.21	4	6	●			
Z618.0130.00	18	1.3	5.8	-	17.7	1.41	4	6	●			ZH18...
Z618.0160.00	18	1.6	5.8	-	17.7	1.71	4	6	●			

Weitere HM Sorten können Sie in der Sortenübersicht im Kapitel "Technische Hinweise" und der Preisliste finden.

Bestellbeispiel:
für Sorte AL41F:
Z618.0110.00/AL41F

More carbide grades you can find in the grades summary in the chapter "technical instructions" and in the price list.

order-example:
grade AL41F:
Z618.0110.00/AL41F

MINIMILL

Nut- und Formzirkularfräsen

groove milling by circular interpolation

Typ Z618 / Z618.X / Z620 / Z620.X

Nutfräsen allgemein

D min. 18 / 20 mm
t max. = 4 / 5

for groove milling general use

D min. 18 / 20 mm
t max. = 4 / 5

Z618/Z620 geradverzahnt / spur-toothed

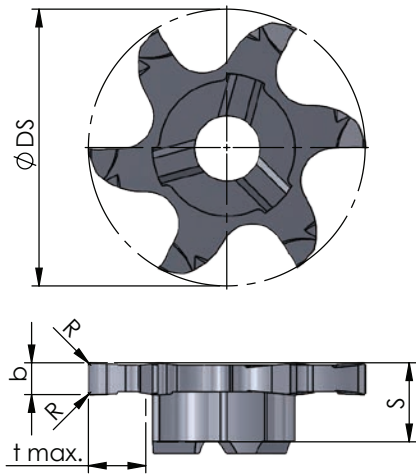

Z618.X/Z620.X kreuzverzahnt / staggered-toothed

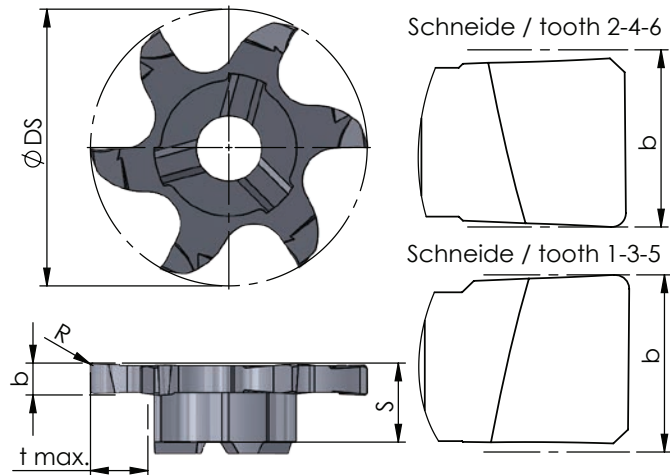

Abmessungen in mm

dimensions in mm



Bestellnummer part number	D min.	S	R	Ø DS	b +0.02	t max.	Zähnezahl number of teeth				für Fräterschaft for milling shank
								K10F	AL41F	P18C	
Z618.0150.01	18	5.8	0.1	17.7	1.5	4	6		●		ZH18...
Z618.0200.02	18	5.8	0.2	17.7	2.0	4	6		●		
Z618.X200.02	18	5.8	0.2	17.7	2.0	4	6		●		
Z618.0250.02	18	5.8	0.2	17.7	2.5	4	6		●		
Z618.X250.02	18	5.8	0.2	17.7	2.5	4	6		●		
Z618.0300.02	18	5.8	0.2	17.7	3.0	4	6		●		
Z618.X300.02	18	5.8	0.2	17.7	3.0	4	6		●		
Z620.0150.01	20	5.8	0.1	19.7	1.5	5	6		●		
Z620.0200.02	20	5.8	0.2	19.7	2.0	5	6		●		
Z620.X200.02	20	5.8	0.2	19.7	2.0	5	6		●		
Z620.0250.02	20	5.8	0.2	19.7	2.5	5	6		●		
Z620.X250.02	20	5.8	0.2	19.7	2.5	5	6		●		
Z620.0300.02	20	5.8	0.2	19.7	3.0	5	6		●		
Z620.X300.02	20	5.8	0.2	19.7	3.0	5	6		●		

Weitere HM Sorten können Sie in der Sortenübersicht im Kapitel "Technische Hinweise" und der Preisliste finden.

Bestellbeispiel:
für Sorte AL41F:
Z618.0150.01/AL41F

More carbide grades you can find in the grades summary in the chapter "technical instructions" and in the price list.

order-example:
grade AL41F:
Z618.0150.01/AL41F

MINIMILL

Nut- und Formzirkularfräsen

groove milling by circular interpolation

Typ Z22

Sicherungsringe DIN 471 / 472
und Nutfräsen allgemein

D min. 22 mm
t max. ≤ 4.5

for circlip grooves DIN 471 / 472
and groove milling general use

D min. 22 mm
t max. ≤ 4.5

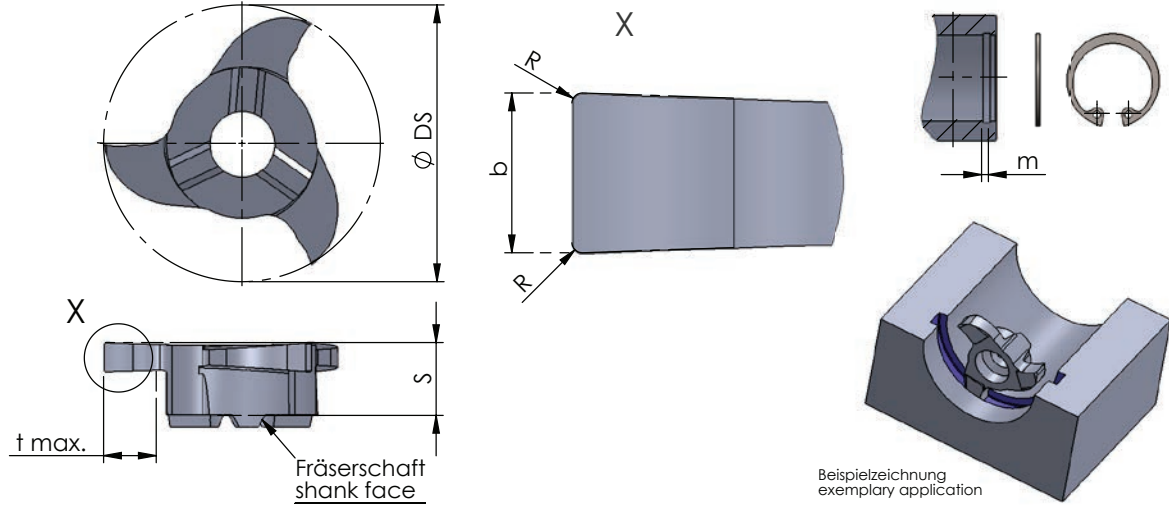

Abmessungen in mm

dimensions in mm

Bestellnummer part number	D min.	Nut-Maß m groove dim. m DIN 471 / DIN 472	S	R	Ø DS	b +0.02 (* b -0.02)	b (inch)	t max.	Zähnezahl number of teeth	Material			für Fräterschaft for milling shank
										K10F	AL41F	P18C	
Z22.0070.00	22	0.7	5.6	-	21.7	0.74*		1.5	3	●			ZH22...
Z22.0079.00	22	-	5.6	-	21.7	0.79	0.031"	1.5	3	●			
Z22.0080.00	22	0.8	5.6	-	21.7	0.84*		1.7	3	●			
Z22.0090.00	22	0.9	5.6	-	21.7	0.94*		1.9	3	●			
Z22.0099.00	22	-	5.6	-	21.7	0.99	0.039"	2.0	3	●			
Z22.0100.00	22	1.0	5.6	-	21.7	1.04*		2.1	3	●			
Z22.0100.01	22	-	5.6	0.10	21.7	1.00		4.5	3	●			
Z22.0110.00	22	1.1	5.7	-	21.7	1.21*		2.5	3	●			
Z22.0117.00	22	-	5.7	-	21.7	1.17	0.046"	2.5	3	●			
Z22.0130.00	22	1.3	5.7	0.10	21.7	1.41*		4.5	3	●			
Z22.0142.01	22	-	5.7	0.10	21.7	1.42	0.056"	4.5	3	●			
Z22.0150.02	22	-	5.7	0.20	21.7	1.50		4.5	3	●			
Z22.0160.00	22	1.6	5.7	0.10	21.7	1.71*		4.5	3	●			
Z22.0185.02	22	1.85	5.7	0.15	21.7	1.96*		4.5	3	●			
↳ ...													

Weitere HM Sorten können Sie in der Sortenübersicht im Kapitel "Technische Hinweise" und der Preisliste finden.

Bestellbeispiel:
für Sorte AL41F:
Z22.0110.00/AL41F

More carbide grades you can find in the grades summary in the chapter "technical instructions" and in the price list.

order-example:
grade AL41F:
Z22.0110.00/AL41F

MINIMILL

Nut- und Formzirkularfräsen

groove milling by circular interpolation

Typ Z22

Sicherungsringe DIN 471 / 472 und Nutfräsen allgemein

D min. 22 mm
t max. ≤ 4.5

for circlip grooves DIN 471 / 472 and groove milling general use

D min. 22 mm
t max. ≤ 4.5

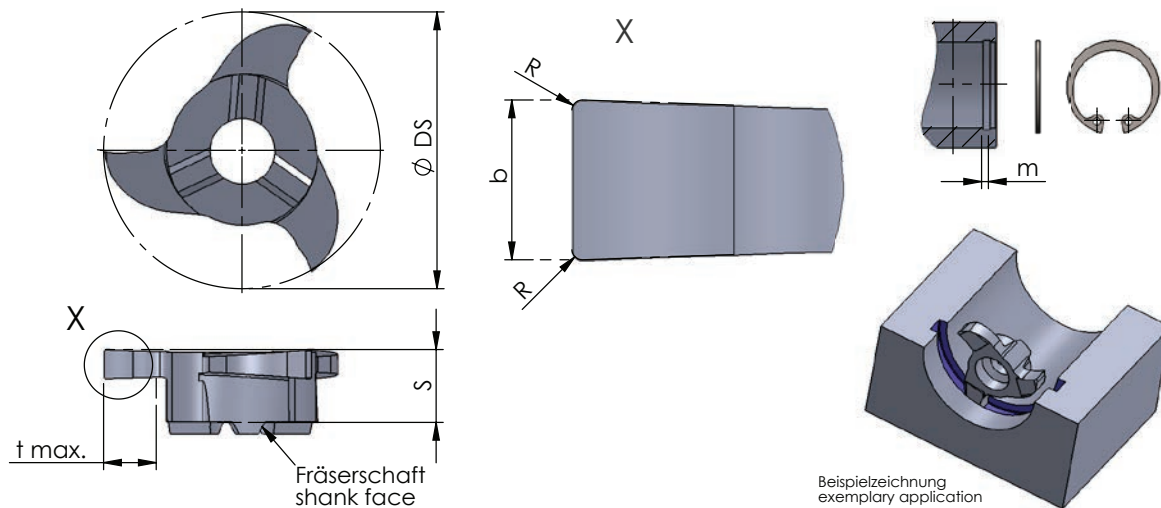

Abmessungen in mm

dimensions in mm



Bestellnummer part number	D min.	Nut-Maß m groove dim. m DIN 471 / DIN 472	S	R	Ø DS	b +0.02 (* b -0.02)	b (inch)	t max.	Zähnezahl number of teeth	Material			für Fräseschaft for milling shank
										K10F	AL41F	P18C	
...													
Z22.0198.02	22	-	5.7	0.20	21.7	1.98	0.078"	4.5	3	●			ZH22...
Z22.0200.02	22	-	5.7	0.20	21.7	2.00		4.5	3	●			
Z22.0215.02	22	2.15	5.7	0.15	21.7	2.26*		4.5	3	●			
Z22.0238.02	22	-	5.7	0.20	21.7	2.39	0.094"	4.5	3	●			
Z22.0250.02	22	-	5.7	0.20	21.7	2.50		4.5	3	●			
Z22.0265.02	22	2.65	5.7	0.15	21.7	2.76*		4.5	3	●			
Z22.0300.02	22	-	5.7	0.20	21.7	3.00		4.5	3	●			
Z22.0315.02	22	3.15	5.7	0.15	21.7	3.26*		4.5	3	●			
Z22.0350.02	22	-	5.7	0.20	21.7	3.50		4.5	3	●			
Z22.0400.02	22	-	5.7	0.20	21.7	4.00		4.5	3	●			
Z22.0415.02	22	4.15	5.7	0.15	21.7	4.26*		4.5	3	●			
Z22.0475.02	22	-	5.7	0.20	21.7	4.75	0.187"	4.5	3	●			
Z22.0515.02	22	5.15	5.7	0.15	21.7	5.26*		4.5	3	●			

Weitere HM Sorten können Sie in der Sortenübersicht im Kapitel "Technische Hinweise" und der Preisliste finden.

Bestellbeispiel:
für Sorte AL41F:
Z22.0515.02/AL41F

More carbide grades you can find in the grades summary in the chapter "technical instructions" and in the price list.

order-example:
grade AL41F:
Z22.0515.02/AL41F

MINIMILL

Nut- und Formzirkularfräsen

groove milling by circular interpolation

Typ Z22

Sicherungsringe, DIN 471 / 472 mit Nutaußenkantenfasung

D min. 22 mm

for circlip grooves DIN 471 / 472 with chamfer

D min. 22 mm

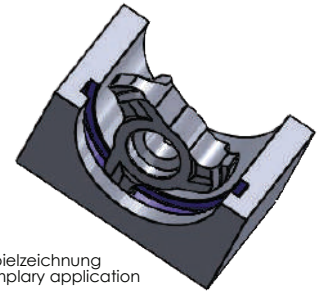
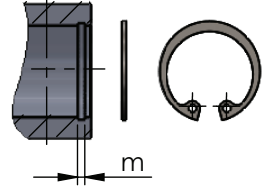
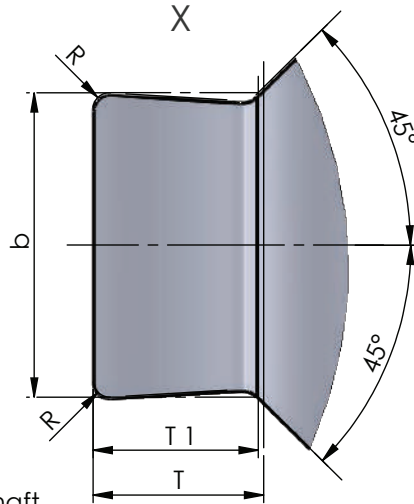
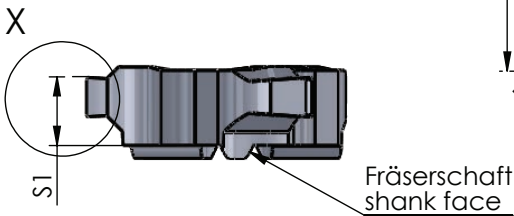
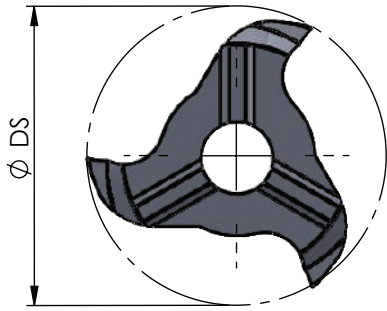

Beispielzeichnung
exemplary application

Abmessungen in mm

dimensions in mm

Bestellnummer part number	D min.	Nut-Maß m groove dim. m DIN 471 / DIN 472	S1	R	Ø DS	b -0.02	T1 -0.04 Formtiefe depth of form	T	Zähnezahl number of teeth	K10F AL41F P18C	für Frälerschaft for milling shank
Z22.1105.30	22	1.1	5.0	-	21.7	1.21	0.49	0.50	3	●	ZH22... ZH28...
Z22.1307.30	22	1.3	5.2	-	21.7	1.41	0.67	0.70	3	●	
Z22.1308.30	22	1.3	5.2	-	21.7	1.41	0.83	0.85	3	●	
Z22.1609.35	22	1.6	5.0	-	21.7	1.71	0.83	0.85	3	●	
Z22.1610.35	22	1.6	5.0	-	21.7	1.71	0.95	1.00	3	●	
Z22.1812.35	22	1.85	5.2	0.15	21.7	1.96	1.23	1.25	3	●	
Z22.2215.35	22	2.15	5.3	0.15	21.7	2.26	1.47	1.50	3	●	
Z22.2616.45	22	2.65	5.0	0.15	21.7	2.76	1.47	1.50	3	●	
Z22.2617.45	22	2.65	5.0	0.15	21.7	2.76	1.72	1.75	3	●	
Z22.3118.45	22	3.15	5.3	0.2	21.7	3.26	1.72	1.75	3	●	
Z22.4120.55	22	4.15	5.3	0.2	21.7	4.26	1.97	2.00	3	●	
Z22.4125.55	22	4.15	5.3	0.2	21.7	4.26	2.47	2.50	3	●	

Weitere HM Sorten können Sie in der Sortenübersicht im Kapitel "Technische Hinweise" und der Preisliste finden.

Bestellbeispiel:
für Sorte AL41F:
Z22.4125.55/AL41F

More carbide grades you can find in the grades summary in the chapter "technical instructions" and in the price list.

order-example:
grade AL41F:
Z22.4125.55/AL41F

MINIMILL

Nut- und Formzirkularfräsen

groove milling by circular interpolation

Typ Z622 / Z622.X

Nutfräsen allgemein

for groove milling general use

D min. 22 mm
t max. = 4.5

D min. 22 mm
t max. = 4.5

Z622 geradverzahnt / spur-toothed

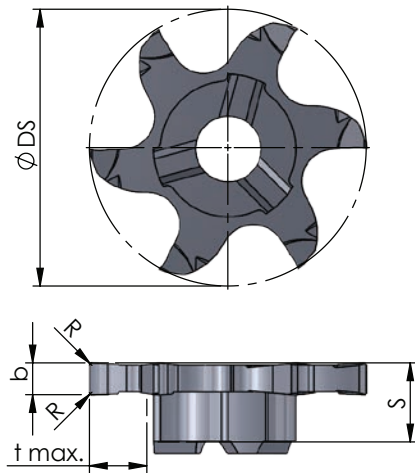

Z622.X kreuzverzahnt / staggered-toothed

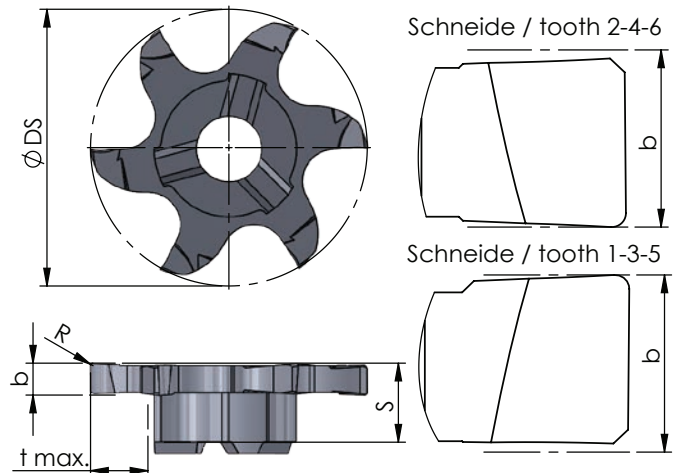

Abmessungen in mm

dimensions in mm



Bestellnummer part number	D min.	S	R	Ø DS	b +0.02	t max.	Zähnezahl number of teeth				für Fräterschaft for milling shank
								K10F	AL41F	P18C	
Z622.0100.01	22	5.8	0.1	21.7	1.0	4.5	6	●			ZH22...
Z622.0150.01	22	6.2	0.1	21.7	1.5	4.5	6	●			
Z622.0200.02	22	6.2	0.2	21.7	2.0	4.5	6	●			
Z622.X200.02	22	6.2	0.2	21.7	2.0	4.5	6	●			
Z622.0250.02	22	6.2	0.2	21.7	2.5	4.5	6	●			
Z622.X250.02	22	6.2	0.2	21.7	2.5	4.5	6	●			
Z622.0300.02	22	6.2	0.2	21.7	3.0	4.5	6	●			
Z622.X300.02	22	6.2	0.2	21.7	3.0	4.5	6	●			
Z622.0400.02	22	6.2	0.2	21.7	4.0	4.5	6	●			
Z622.X400.02	22	6.2	0.2	21.7	4.0	4.5	6	●			

Weitere HM Sorten können Sie in der Sortenübersicht im Kapitel "Technische Hinweise" und der Preisliste finden.

Bestellbeispiel:
für Sorte AL41F:
Z622.0150.01/AL41F

More carbide grades you can find in the grades summary in the chapter "technical instructions" and in the price list.

order-example:
grade AL41F:
Z622.0150.01/AL41F

MINIMILL

Nut- und Formzirkularfräsen

groove milling by circular interpolation

Typ Z25

Nutfräsen allgemein

for groove milling general use

D min. 25 mm
t max. = 5.0

D min. 25 mm
t max. = 5.0

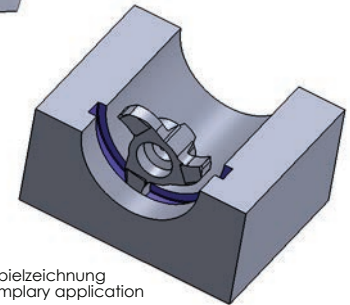
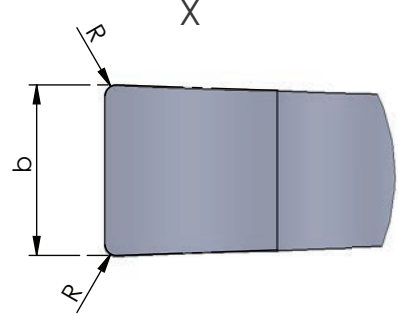
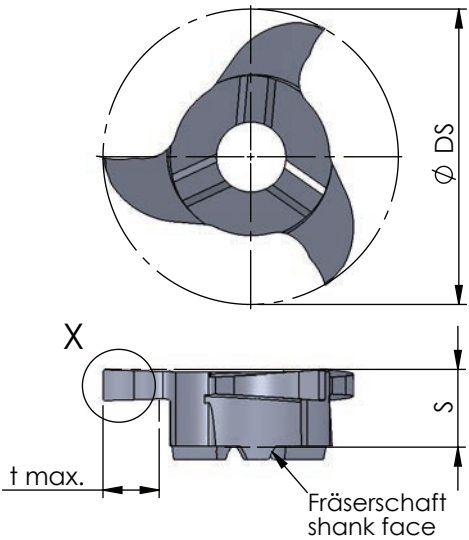

Abmessungen in mm

dimensions in mm

Bestellnummer part number	D min.	S	R	Ø DS	b +0.02	b (inch)	t max.	Zähnezahl number of teeth				für Frälerschaft for milling shank
									K10F	AL41F	P18C	
Z25.0200.02	25	6.6	0.2	24.8	2.0		5.0	3	●			ZH28...
Z25.0250.02	25	6.6	0.2	24.8	2.5		5.0	3	●			
Z25.0300.02	25	6.6	0.2	24.8	3.0		5.0	3	●			
Z25.0318.02	25	6.6	0.2	24.8	3.18	0.125"	5.0	3	●			
Z25.0350.02	25	6.6	0.2	24.8	3.5		5.0	3	●			
Z25.0400.02	25	6.6	0.2	24.8	4.0		5.0	3	●			

Weitere HM Sorten können Sie in der Sortenübersicht im Kapitel "Technische Hinweise" und der Preisliste finden.

Bestellbeispiel:
für Sorte AL41F:
Z25.0350.02/AL41F

More carbide grades you can find in the grades summary in the chapter "technical instructions" and in the price list.

order-example:
grade AL41F:
Z25.0350.02/AL41F

MINIMILL

Nut- und Formzirkularfräsen

groove milling by circular interpolation

Typ Z625.X

Nutfräsen allgemein

general use

D min. 25 mm
t max. = 5

D min. 25 mm
t max. = 5

Z625.X kreuzverzahnt / staggered-toothed

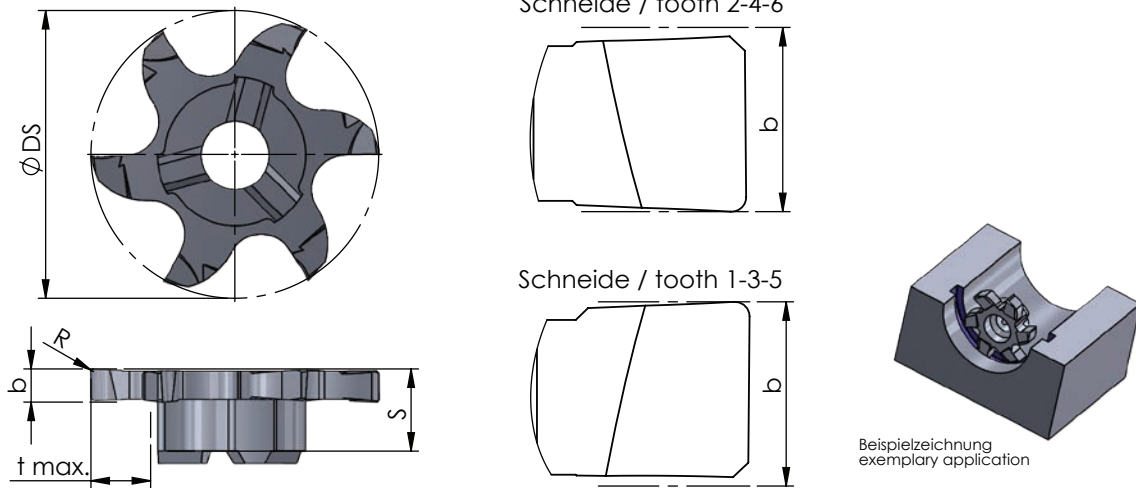

Abmessungen in mm

dimensions in mm

Bestellnummer part number	D min.	S	R	Ø DS	b +0.02	t max.	Zähnezahl number of teeth				für Fräterschaft for milling shank
								K10F	AL41F	P18C	
Z625.X250.02	25	6.4	0.2	24.8	2.5	5.0	6	●			ZH28...
Z625.X300.02	25	6.4	0.2	24.8	3.0	5.0	6	●			
Z625.X400.02	25	6.4	0.2	24.8	4.0	5.0	6	●			
Z625.X500.02	25	6.4	0.2	24.8	5.0	5.0	6	●			
Z625.X600.02	25	6.4	0.2	24.8	6.0	5.0	6	●			

Weitere HM Sorten können Sie in der Sortenübersicht im Kapitel "Technische Hinweise" und der Preisliste finden.

Bestellbeispiel:
für Sorte AL41F:
Z625.X250.02/AL41F

More carbide grades you can find in the grades summary in the chapter "technical instructions" and in the price list.

order-example:
grade AL41F:
Z625.X250.02/AL41F

MINIMILL

Nut- und Formzirkularfräsen

groove milling by circular interpolation

Typ Z28

Nutfräsen allgemein

for groove milling general use

D min. 28 mm
t max. = 6.5

D min. 28 mm
t max. = 6.5

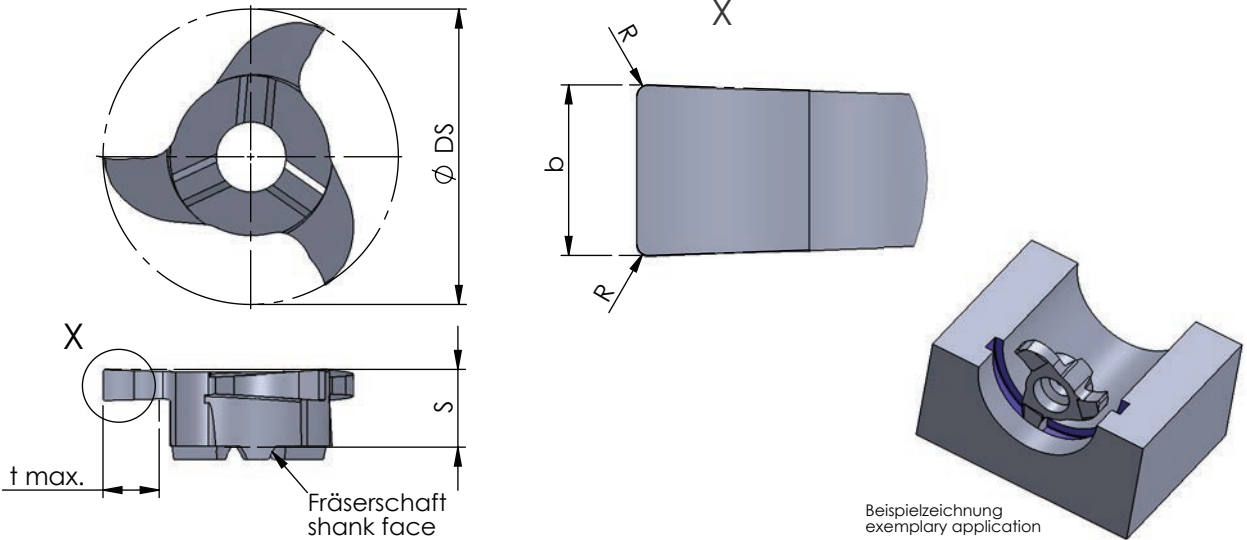

Beispielzeichnung
exemplary application

Abmessungen in mm

dimensions in mm

Bestellnummer part number	D min.	S	R	Ø DS	b +0.02	b (inch)	t max.	Zähnezahl number of teeth				für Fräterschaft for milling shank
									K10F	AL41F	P18C	
Z28.0150.00	28	6.6	0.2	27.7	1.50		6.5	3	●			ZH28...
Z28.0200.02	28	6.6	0.2	27.7	2.00		6.5	3	●			
Z28.0238.02	28	6.6	0.2	27.7	2.39	0.094"	6.5	3	●			
Z28.0250.02	28	6.6	0.2	27.7	2.50		6.5	3	●			
Z28.0300.02	28	6.6	0.2	27.7	3.00		6.5	3	●			
Z28.0318.02	28	6.6	0.2	27.7	3.18	0.125"	6.5	3	●			
Z28.0350.02	28	6.6	0.2	27.7	3.50		6.5	3	●			
Z28.0400.02	28	6.6	0.2	27.7	4.00		6.5	3	●			
Z28.0475.02	28	6.6	0.2	27.7	4.75	0.187"	6.5	3	●			
Z28.0500.02	28	6.6	0.2	27.7	5.00		6.5	3	●			
Z28.0600.02	28	6.6	0.2	27.7	6.00		6.5	3	●			

Weitere HM Sorten können Sie in der Sortenübersicht im Kapitel "Technische Hinweise" und der Preisliste finden.

Bestellbeispiel:
für Sorte AL41F:
Z28.0350.02/AL41F

More carbide grades you can find in the grades summary in the chapter "technical instructions" and in the price list.

order-example:
grade AL41F:
Z28.0350.02/AL41F

MINIMILL

Nut- und Formzirkularfräsen

groove milling by circular interpolation

Typ Z28

Nutfräsen allgemein

for groove milling general use

D min. 28.3 mm
t max. = 9.3

D min. 28.3 mm
t max. = 9.3

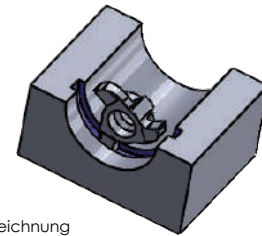
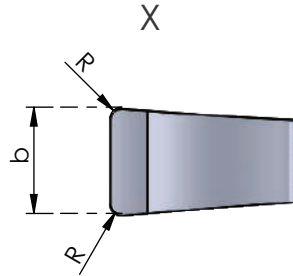
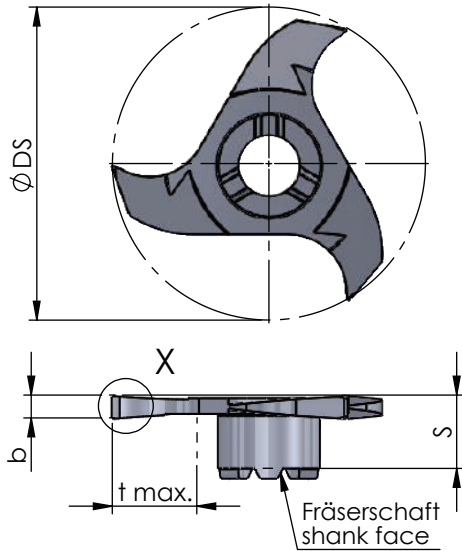

Beispielzeichnung
exemplary application

Abmessungen in mm

dimensions in mm

Bestellnummer part number	D min.	S	R	Ø DS	b -0.02	t max.	Zähnezahl number of teeth				für Fräterschaft for milling shank
								K10F	AL41F	P18C	
Z28.0150.02.9	28.3	6.5	0.2	28	1.5	9.3	3	●			
Z28.0200.02.9	28.3	6.5	0.2	28	2.0	9.3	3		●		ZH33...
Z28.0250.02.9	28.3	6.5	0.2	28	2.5	9.3	3			●	

Weitere HM Sorten können Sie in der Sortenübersicht im Kapitel "Technische Hinweise" und der Preisliste finden.

Bestellbeispiel:
für Sorte AL41F:
Z28.0150.02.9/AL41F

More carbide grades you can find in the grades summary in the chapter "technical instructions" and in the price list.

order-example:
grade AL41F:
Z28.0150.02.9/AL41F

MINIMILL

Nut- und Formzirkularfräsen

groove milling by circular interpolation

Typ Z628 / Z628.X

Sicherungsringe DIN 471 / 472
und Nutfräsen allgemein

D min. 28 mm
t max. = 6.5

for circlip grooves DIN 471 / 472
and general use

D min. 28 mm
t max. = 6.5

Z628 geradverzahnt / spur-toothed

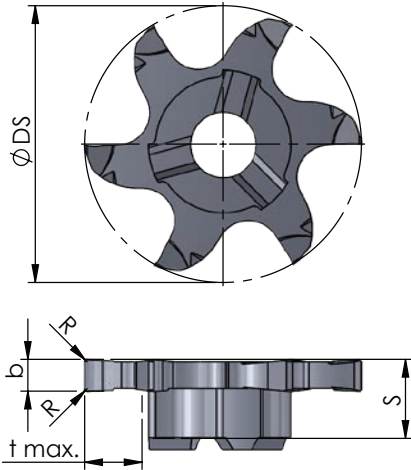

Z628.X kreuzverzahnt / staggered-toothed

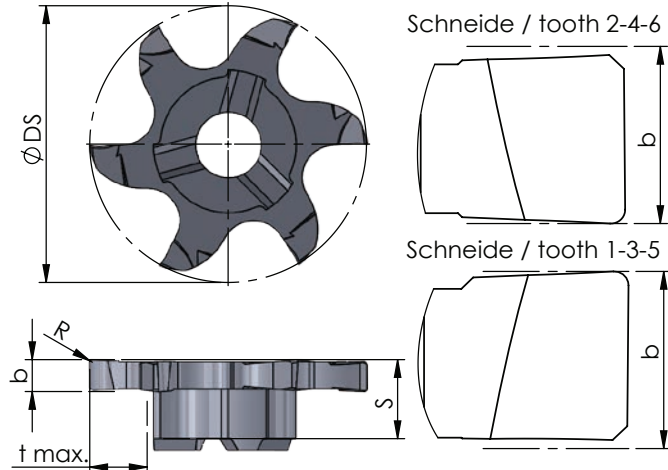

Abmessungen in mm

dimensions in mm

Bestellnummer part number	D min.	Nut-Maß m groove dim. m DIN 471 / DIN 472	S	R	Ø DS	b +0.02 (* b -0.02)	t max.	Zähnezahl number of teeth	K10F AL41F P18C	für Fräterschaft for milling shank
Z628.0100.01	28	-	6.0	0.1	27.7	1.0	6.5	6	●	ZH28...
Z628.0150.01	28	-	6.4	0.1	27.7	1.5	6.5	6	●	
Z628.0185.02	28	1.85	6.4	0.2	27.7	1.96 *	6.5	6	●	
Z628.0200.02	28	-	6.4	0.2	27.7	2.0	6.5	6	●	
Z628.0215.02	28	2.15	6.2	0.2	27.7	2.26 *	6.5	6	●	
Z628.0250.02	28	-	6.4	0.2	27.7	2.5	6.5	6	●	
Z628.X250.02	28	-	6.2	0.2	27.7	2.5	6.5	6	●	
Z628.0300.02	28	-	6.4	0.2	27.7	3.0	6.5	6	●	
Z628.X300.02	28	-	6.2	0.2	27.7	3.0	6.5	6	●	
Z628.0400.02	28	-	6.4	0.2	27.7	4.0	6.5	6	●	
Z628.X400.02	28	-	6.2	0.2	27.7	4.0	6.5	6	●	
Z628.0500.02	28	-	6.4	0.2	27.7	5.0	6.5	6	●	
Z628.X500.02	28	-	6.2	0.2	27.7	5.0	6.5	6	●	
Z628.0600.02	28	-	6.4	0.2	27.7	6.0	6.5	6	●	
Z628.X600.02	28	-	6.2	0.2	27.7	6.0	6.5	6	●	

Weitere HM Sorten können Sie in der Sortenübersicht im Kapitel "Technische Hinweise" und der Preisliste finden.

Bestellbeispiel:
für Sorte AL41F: Z628.0150.01/AL41F

More carbide grades you can find in the grades summary in the chapter "technical instructions" and in the price list.

order-example:
grade AL41F: Z628.0150.01/AL41F

MINIMILL

Nut- und Formzirkularfräsen

groove milling by circular interpolation

Typ Z628

Nutfräsen allgemein

for groove milling general use

D min. 28 mm
t max. = 9.3

D min. 28 mm
t max. = 9.3

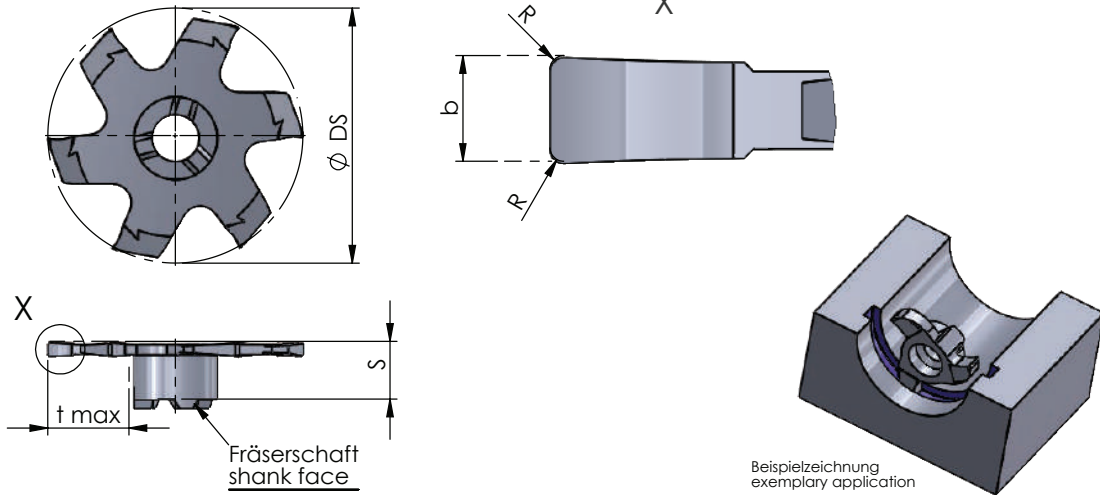

Abmessungen in mm

dimensions in mm

Bestellnummer part number	D min.	S	R	Ø DS	b +0.02	t max.	Zähnezahl number of teeth	K10F AL41F P18C	für Fräseschaft for milling shank
Z628.150.02.9	28	6.2	0.2	27.7	1.5	9.3	6	●	ZH33...

Weitere HM Sorten können Sie in der Sortenübersicht im Kapitel "Technische Hinweise" und der Preisliste finden.

Bestellbeispiel:
für Sorte AL41F:
Z628.150.02.9/AL41F

More carbide grades you can find in the grades summary in the chapter "technical instructions" and in the price list.

order-example:
grade AL41F:
Z628.150.02.9/AL41F

MINIMILL

Nut- und Formzirkularfräsen

groove milling by circular interpolation

Typ Z32

Nutfräsen allgemein

for groove milling general use

D min. 32 mm
t max. = 8.5

D min. 32 mm
t max. = 8.5

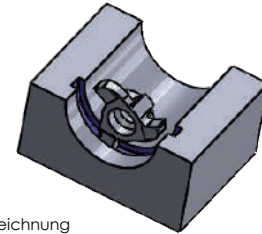
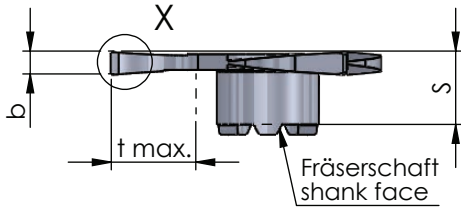
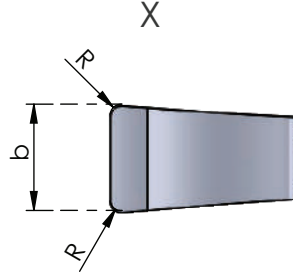
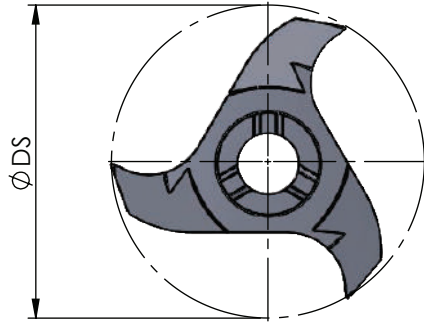

Beispielzeichnung
exemplary application

Abmessungen in mm

dimensions in mm

Bestellnummer part number	D min.	S	R	Ø DS	b +0.02	t max.	Zähnezahl number of teeth	Material			für Frälerschaft for milling shank
								K10F	AL41F	P18C	
Z32.0200.00	32	6.5	0.2	31.7	2.0	8.5	3	●			
Z32.0250.02	32	6.5	0.2	31.7	2.5	8.5	3	●			ZH28...
Z32.0300.02	32	6.5	0.2	31.7	3.0	8.5	3	●			

Weitere HM Sorten können Sie in der Sortenübersicht im Kapitel "Technische Hinweise" und der Preisliste finden.

Bestellbeispiel:
für Sorte AL41F:
Z32.0300.02/AL41F

More carbide grades you can find in the grades summary in the chapter "technical instructions" and in the price list.

order-example:
grade AL41F:
Z32.0300.02/AL41F

MINIMILL

Nut- und Formzirkularfräsen

groove milling by circular interpolation

Typ Z33

Nutfräsen allgemein

for groove milling general use

D min. 33 / 33.9 mm
t max. = 10 / 12

D min. 33 / 33.9 mm
t max. = 10 / 12

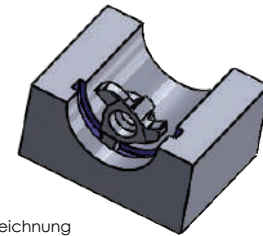
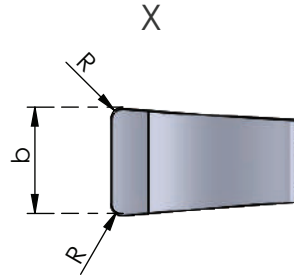
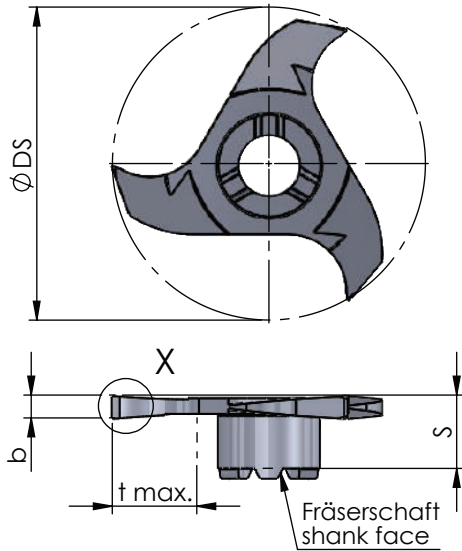

Beispielzeichnung
exemplary application

Abmessungen in mm

dimensions in mm

Bestellnummer part number	D min.	S	R	Ø DS	b -0.02	t max.	Zähnezahl number of teeth	Material			für Frälerschaft for milling shank
								K10F	AL41F	P18C	
Z33.110.42.10	33	6.5	0.2	32.7	1.10	10	3	●			ZH22...
Z33.120.42.10	33	6.5	0.2	32.7	1.20	10	3	●			
Z33.132.42.10	33	6.5	0.2	32.7	1.32	10	3	●			
Z33.150.42.10	33	6.5	0.2	32.7	1.50	10	3	●			
Z33.160.42.10	33	6.5	0.2	32.7	1.60	10	3	●			
Z33.170.42.10	33	6.5	0.2	32.7	1.70	10	3	●			
Z33.200.42.10	33	6.5	0.2	32.7	2.00	10	3	●			
Z33.250.42.10	33	6.5	0.2	32.7	2.50	10	3	●			
Z33.170.42.12	33.9	6.5	0.2	33.6	1.70	12	3	●			ZH33...

Weitere HM Sorten können Sie in der Sortenübersicht im Kapitel "Technische Hinweise" und der Preisliste finden.

Bestellbeispiel:
für Sorte AL41F:
Z33.200.42.10/AL41F

More carbide grades you can find in the grades summary in the chapter "technical instructions" and in the price list.

order-example:
grade AL41F:
Z33.200.42.10/AL41F

MINIMILL

Nut- und Formzirkularfräsen

groove milling by circular interpolation

Typ Z635 / Z635.X

Nutfräsen allgemein

for groove milling general use

D min. 35 mm
t max. = 10

D min. 35 mm
t max. = 10

Z635 geradverzahnt / spur-toothed

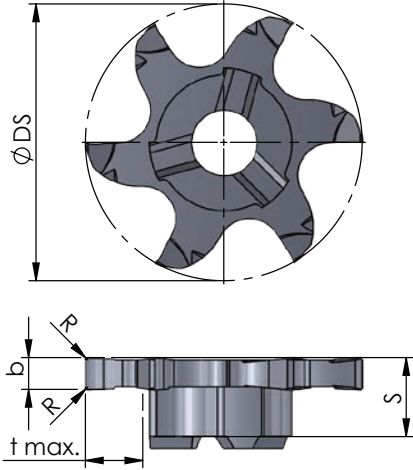

Z635.X kreuzverzahnt / staggered-toothed

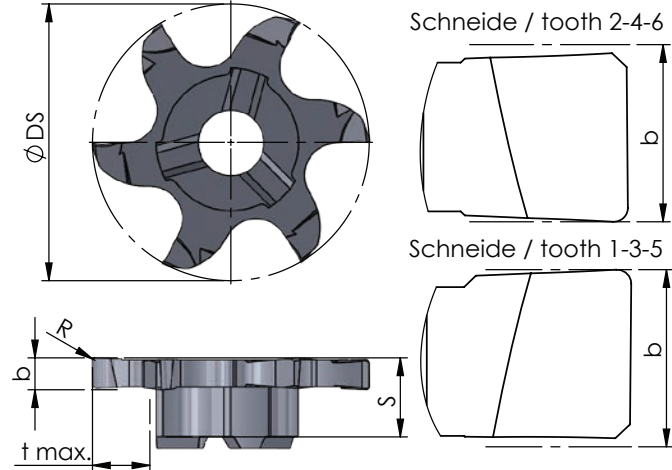

Abmessungen in mm

dimensions in mm

Bestellnummer part number	D min.	S	R	Ø DS	b +0.02	t max.	Zähnezahl number of teeth				für Fräseschaft for milling shank
								K10F	AL41F	P18C	
Z635.0150.01	35	6.25	0.1	34.7	1.5	10.0	6	●			ZH28...
Z635.0200.02	35	6.25	0.2	34.7	2.0	10.0	6		●		
Z635.X200.02	35	6.25	0.2	34.7	2.0	10.0	6		●		
Z635.0250.02	35	6.25	0.2	34.7	2.5	10.0	6		●		
Z635.X250.02	35	6.25	0.2	34.7	2.5	10.0	6		●		
Z635.0300.02	35	6.25	0.2	34.7	3.0	10.0	6		●		
Z635.X300.02	35	6.25	0.2	34.7	3.0	10.0	6		●		

Weitere HM Sorten können Sie in der Sortenübersicht im Kapitel "Technische Hinweise" und der Preisliste finden.

Bestellbeispiel:
für Sorte AL41F:
Z635.0150.01/AL41F

More carbide grades you can find in the grades summary in the chapter "technical instructions" and in the price list.

order-example:
grade AL41F:
Z635.0150.01/AL41F

MINIMILL

Nut- und Formzirkularfräsen

groove milling by circular interpolation

Typ Z637 / Z637X / Z640

Nutfräsen allgemein

for groove milling general use

D min. 37 / 40 mm
t max. = 12 / 13.5

D min. 37 / 40 mm
t max. = 12 / 13.5



Z637/Z640 geradverzahnt / spur-toothed

Z637.X kreuzverzahnt / staggered-toothed

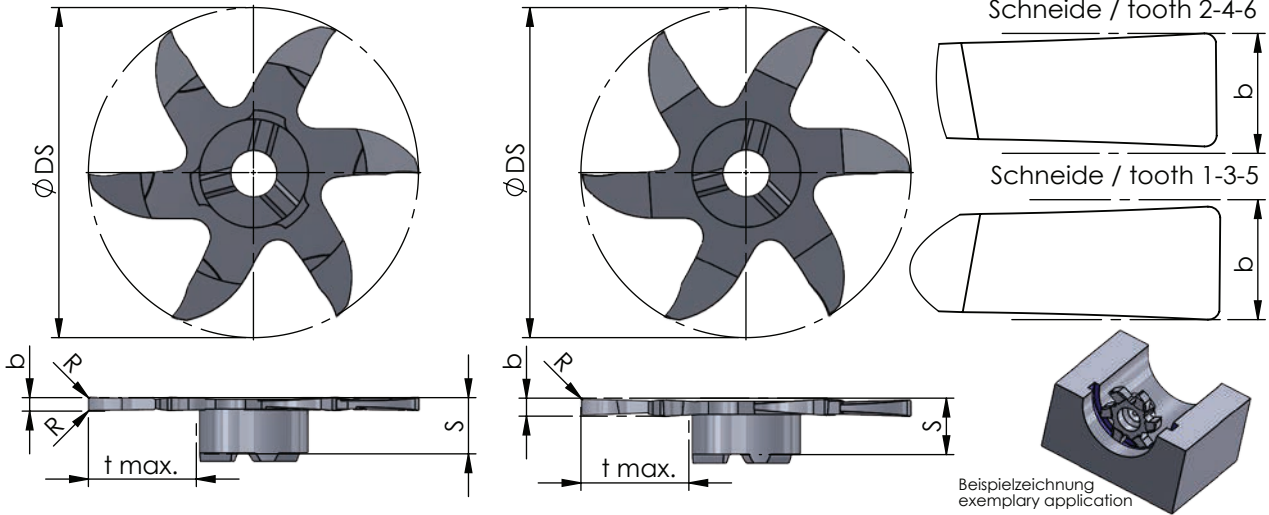

Abmessungen in mm

dimensions in mm

Bestellnummer part number	D min.	S	R	Ø DS	b +0.02	t max.	Zähnezahl number of teeth				für Fräseschaft for milling shank
								K10F	AL41F	P18C	
Z637.0100.01	37	6.25	0.1	36.7	1.0	12.0	6	●			ZH22...
Z640.0100.01	40	6.25	0.1	39.7	1.0	13.5	6		●		
Z637.0150.01	37	6.25	0.1	36.7	1.5	12.0	6		●		
Z637.X150.01	37	6.25	0.1	36.7	1.5	12.0	6		●		
Z640.0150.01	40	6.25	0.1	39.7	1.5	13.5	6		●		
Z637.X200.02	37	6.25	0.2	36.7	2.0	12.0	6		●		

Weitere HM Sorten können Sie in der Sortenübersicht im Kapitel "Technische Hinweise" und der Preisliste finden.

Bestellbeispiel:
für Sorte AL41F:
Z637.0100.01/AL41F

More carbide grades you can find in the grades summary in the chapter "technical instructions" and in the price list.

order-example:
grade AL41F:
Z637.0100.01/AL41F

MINIMILL

Nut- und Formzirkularfräsen

groove milling by circular interpolation

Typ Z637 / Z640

Nutfräsen, Trennfräsen und Schlitzfräsen
b = 0.4 - 0.8 mm

for groove and key way milling
b = 0.4 - 0.8 mm

D min. 37 / 40 mm
t max. = 12 / 13.5

D min. 37 / 40 mm
t max. = 12 / 13.5

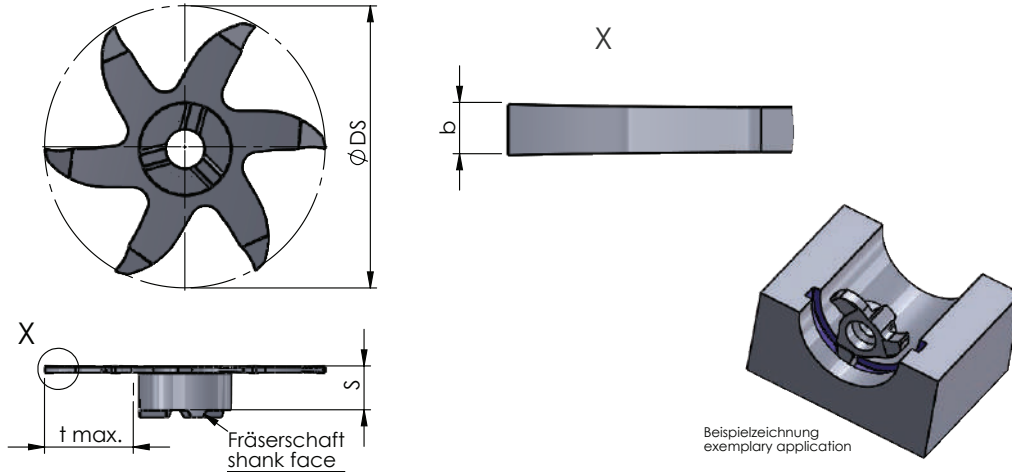

Abmessungen in mm

dimensions in mm

Bestellnummer part number	D min.	S	Ø DS	b +0.05	t max.	Zähnezahl number of teeth				für Fräseerschaft for milling shank
							K10F	AL41F	P18C	
Z640.0040.00	40	6.0	39.7	0.4	13.5	6		●		ZH22...
Z637.0050.00	37	6.0	36.7	0.5	12.0	6		●		
Z640.0050.00	40	6.0	39.7	0.5	13.5	6		●		
Z637.0060.00	37	5.7	36.7	0.6	12.0	6		●		
Z640.0060.00	40	5.7	39.7	0.6	13.5	6		●		
Z637.0080.00	37	6.0	36.7	0.8	12.0	6		●		
Z640.0080.00	40	6.0	39.7	0.8	13.5	6		●		

Weitere HM Sorten können Sie in der Sortenübersicht im Kapitel "Technische Hinweise" und der Preisliste finden.

Bestellbeispiel:
für Sorte AL41F:
Z637.0050.00/AL41F

More carbide grades you can find in the grades summary in the chapter "technical instructions" and in the price list.

order-example:
grade AL41F:
Z637.0050.00/AL41F

MINIMILL

Nut- und Formzirkularfräsen

groove milling by circular interpolation

Typ Z12

Vollradius

full radius

D min. 12 mm
t max. = 2.5

D min. 12 mm
t max. = 2.5

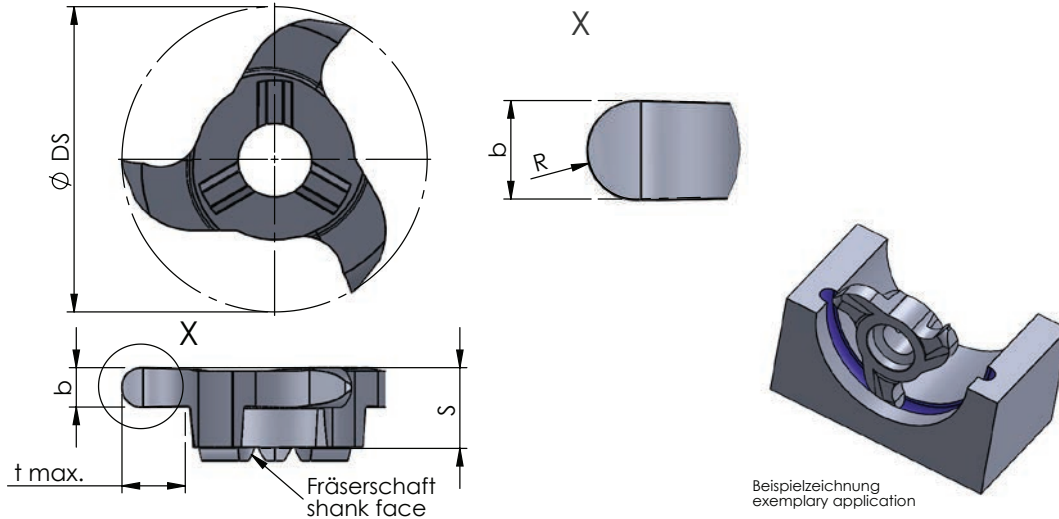

Abmessungen in mm

dimensions in mm

Bestellnummer part number	Abmessungen in mm / dimensions in mm							Material / Material			für Fräterschaft for milling shank
	D min.	S	R	$\varnothing DS$	b +0.03	t max.	Zähnezahl number of teeth	K10F	AL41F	P18C	
Z12.0011.22	12	3.5	1.1	11.7	2.2	2.5	3		●		ZH10...

Weitere HM Sorten können Sie in der Sortenübersicht im Kapitel "Technische Hinweise" und der Preisliste finden.

Bestellbeispiel:
für Sorte AL41F:
Z12.0011.22/AL41F

More carbide grades you can find in the grades summary in the chapter "technical instructions" and in the price list.

order-example:
grade AL41F:
Z12.0011.22/AL41F

MINIMILL

Nut- und Formzirkularfräsen

groove milling by circular interpolation

Typ Z16

Vollradius

full radius

D min. 16 mm
t max. = 3.5

D min. 16 mm
t max. = 3.5

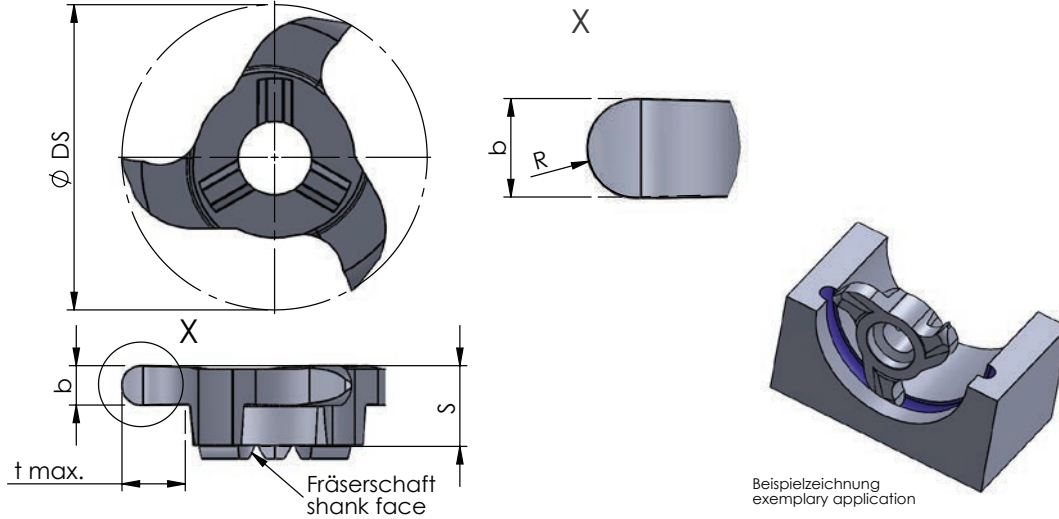

Abmessungen in mm

dimensions in mm

Bestellnummer part number	Abmessungen in mm / dimensions in mm							Material / Material			für Fräseschaft for milling shank
	D min.	S	R	Ø DS	b +0.03	t max.	Zähnezahl number of teeth	K10F	AL41F	P18C	
Z16.0011.22	16	4.5	1.1	15.7	2.2	3.5	3		●		ZH14...

Weitere HM Sorten können Sie in der Sortenübersicht im Kapitel "Technische Hinweise" und der Preisliste finden.

Bestellbeispiel:
für Sorte AL41F:
Z16.0011.22/AL41F

More carbide grades you can find in the grades summary in the chapter "technical instructions" and in the price list.

order-example:
grade AL41F:
Z16.0011.22/AL41F

MINIMILL

Nut- und Formzirkularfräsen

groove milling by circular interpolation

Typ Z18

Vollradius

D min. 18 mm
t max. = 3.5

full radius

D min. 18 mm
t max. = 3.5

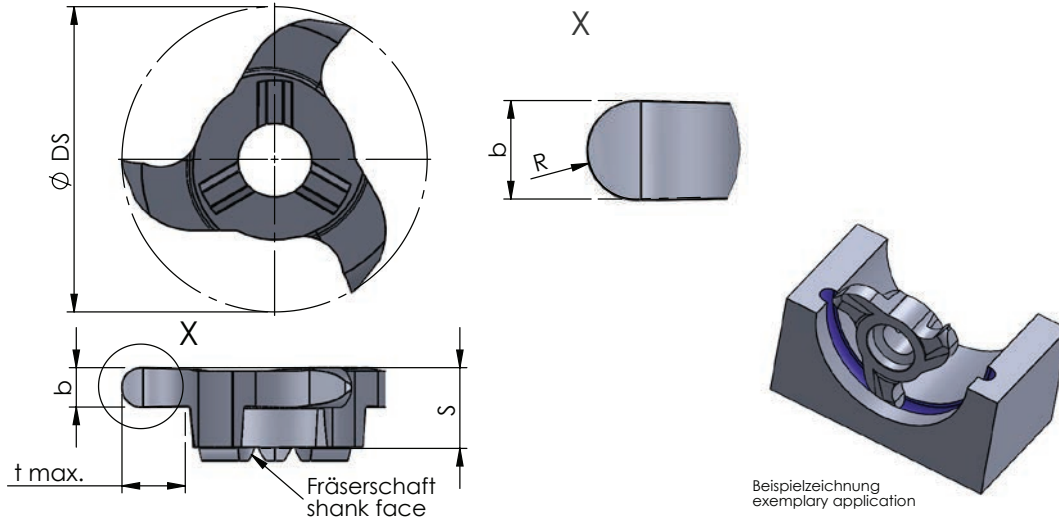

Abmessungen in mm

dimensions in mm

Bestellnummer part number	D min.	S	R	Ø DS	b +0.03	b (inch)	t max.	Zähnezahl number of teeth				für Fräterschaft for milling shank
									K10F	AL41F	P18C	
Z18.0010.20	18	5.75	1.0	17.7	2.0		3.5	3	●			ZH18...
Z18.0011.22	18	5.75	1.1	17.7	2.2		3.5	3		●		
Z18.U011.23	18	5.75	1.19	17.7	2.38	0.094"	3.5	3	●	●		
Z18.0015.30	18	5.75	1.5	17.7	3.0		3.5	3		●		

Weitere HM Sorten können Sie in der Sortenübersicht im Kapitel "Technische Hinweise" und der Preisliste finden.

Bestellbeispiel:
für Sorte AL41F:
Z18.0010.20/AL41F

More carbide grades you can find in the grades summary in the chapter "technical instructions" and in the price list.

order-example:
grade AL41F:
Z18.0010.20/AL41F

MINIMILL

Nut- und Formzirkularfräsen

groove milling by circular interpolation

Typ Z22

Vollradius

D min. 22 mm
t max. = 4.5

full radius

D min. 22 mm
t max. = 4.5

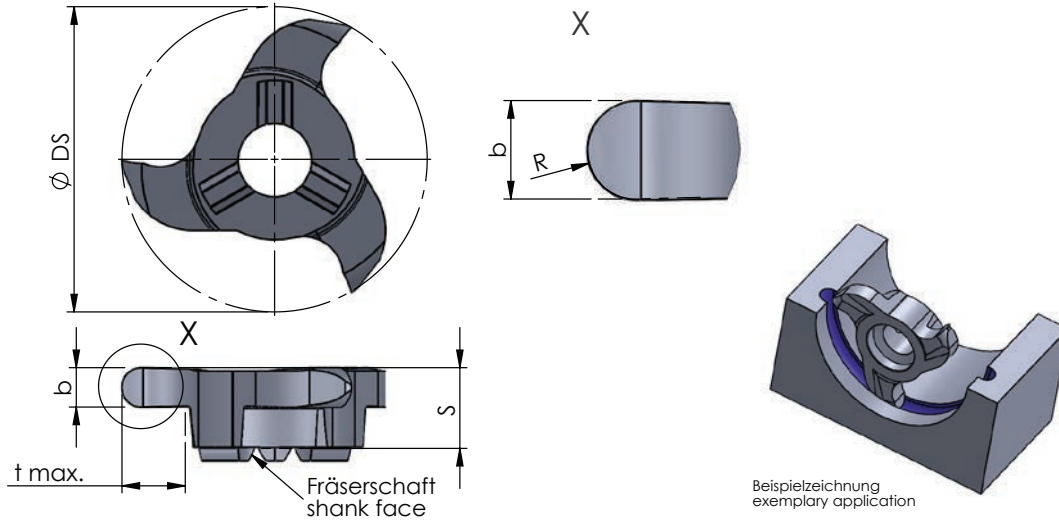

Abmessungen in mm

dimensions in mm

Bestellnummer part number	D min.	S	R	Ø DS	b +0.03	b (inch)	t max.	Zähnezahl number of teeth				für Fräterschaft for milling shank
									K10F	AL41F	P18C	
Z22.0005.10	22	5.75	0.5	21.7	1.0		4.5	3		●		ZH22...
Z22.0008.16	22	5.75	0.8	21.7	1.6		4.5	3		●		
Z22.0010.20	22	5.75	1.0	21.7	2.0		4.5	3	●	●		
Z22.0012.24	22	5.75	1.2	21.7	2.4		4.5	3		●		
Z22.0014.28	22	5.75	1.4	21.7	2.8		4.5	3		●		
Z22.0015.30	22	5.75	1.5	21.7	3.0		4.5	3		●		
Z22.U015.31	22	5.75	1.57	21.7	3.17	0.125"	4.5	3		●		
Z22.0020.40	22	5.75	2.0	21.7	4.0		4.5	3		●		
Z22.0022.44	22	5.75	2.2	21.7	4.4		4.5	3		●		
Z22.0025.50	22	5.75	2.5	21.7	5.0		4.5	3		●		

Weitere HM Sorten können Sie in der Sortenübersicht im Kapitel "Technische Hinweise" und der Preisliste finden.

Bestellbeispiel:
für Sorte AL41F:
Z22.0025.50/AL41F

More carbide grades you can find in the grades summary in the chapter "technical instructions" and in the price list.

order-example:
grade AL41F:
Z22.0025.50/AL41F

MINIMILL

Nut- und Formzirkularfräsen

groove milling by circular interpolation

Impressionen

impressions



MINIMILL

Nut- und Formzirkularfräsen

groove milling by circular interpolation

Typ Z610

metrisches ISO-Gewinde,
Teilprofil, innen

metric ISO-thread,
partial profile, internal

ab Gewindegröße M12 x 1.0

starting at thread size M12 x 1.0

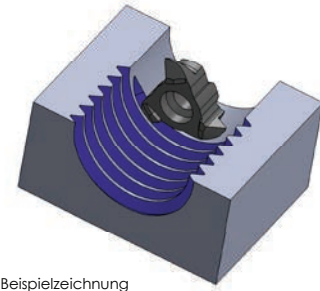
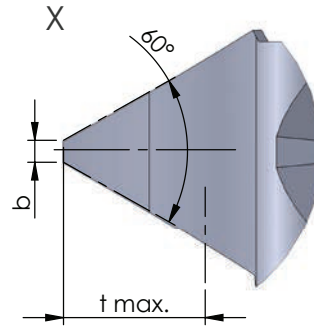
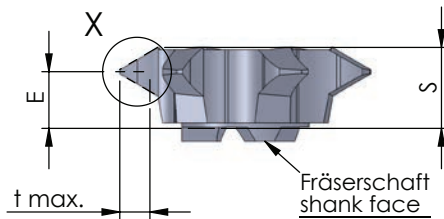
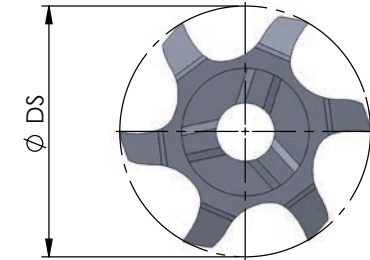

Beispielzeichnung
exemplary application

Abmessungen in mm

dimensions in mm

Bestellnummer part number	min. Gewindegröße min. thread size	Steigung P pitch P	S	E	Ø DS	b	t max.	Zähnezahl number of teeth	K10F AL41F P18C	für Fräseschaft for milling shank
Z610.0510.01	M12	1.0-1.75	3.2	2.4	9.8	0.13	1.08	6	●	ZH10...
Z610.0720.01	M14	1.0-2.0	3.2	2.2	10.1	0.13	1.25	6	●	
Z610.0815.01	M16	1.5-2.75	3.2	2.0	11.0	0.19	1.67	6	●	
Z610.2530.01	M16	2.0-3.0	3.2	1.9	11.1	0.25	1.78	6	●	

Weitere HM Sorten können Sie in der Sortenübersicht im Kapitel "Technische Hinweise" und der Preisliste finden.

Bestellbeispiel:
für Sorte AL41F:
Z610.0510.01/AL41F

More carbide grades you can find in the grades summary in the chapter "technical instructions" and in the price list.

order-example:
grade AL41F:
Z610.0510.01/AL41F

MINIMILL

Nut- und Formzirkularfräsen

groove milling by circular interpolation

Typ Z10

metrisches ISO-Gewinde, Vollprofil, innen

metric ISO-thread, full profile, internal

ab Gewindegröße M12 x 0.75

starting at thread size M12 x 0.75

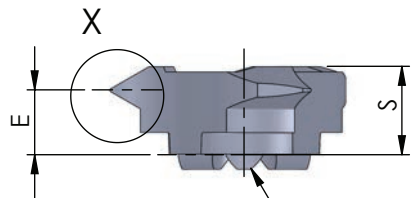
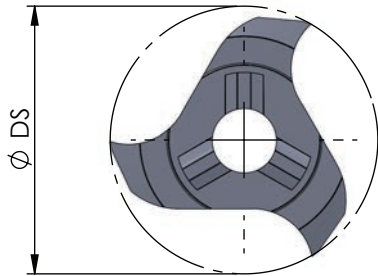

Fräseschaft
shank face

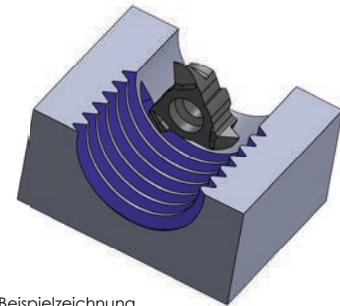
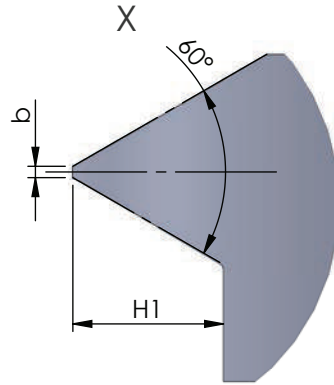

Beispielzeichnung
exemplary application

Abmessungen in mm

dimensions in mm

Bestellnummer part number	min. Gewindegröße min. thread size	Steigung P pitch P	S	E	Ø DS	b	H1	Zähnezahl number of teeth	K10F AL41F P18C	für Fräseschaft for milling shank
Z10.0407.02	M12	0.75	3.6	3.1	9.7	0.09	0.41	3	●	ZH10...
Z10.0510.02	M12	1.00	3.6	3.0	9.7	0.13	0.54	3	●	
Z10.0815.02	M14	1.50	3.6	2.8	9.7	0.19	0.81	3	●	
Z10.0917.02	M14	1.75	3.6	2.7	9.7	0.20	0.95	3	●	
Z10.1020.02	M14	2.00	3.6	2.6	9.7	0.25	1.08	3	●	
Z10.1325.02	M16	2.50	3.6	2.4	9.7	0.31	1.35	3	●	

Weitere HM Sorten können Sie in der Sortenübersicht im Kapitel "Technische Hinweise" und der Preisliste finden.

Bestellbeispiel:
für Sorte AL41F:
Z10.0407.02/AL41F

More carbide grades you can find in the grades summary in the chapter "technical instructions" and in the price list.

order-example:
grade AL41F:
Z10.0407.02/AL41F

MINIMILL

Nut- und Formzirkularfräsen

groove milling by circular interpolation

Typ Z12

metrisches ISO-Gewinde, Teilprofil, innen

metric ISO-thread, partial profile, internal

ab Gewindegröße M14 x 1.0

starting at thread size M14 x 1.0

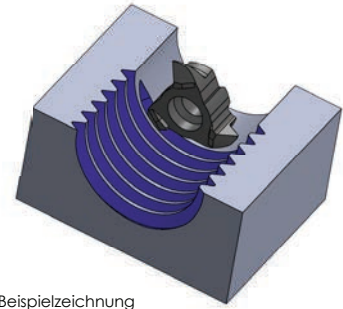
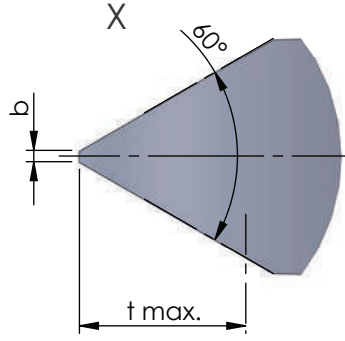
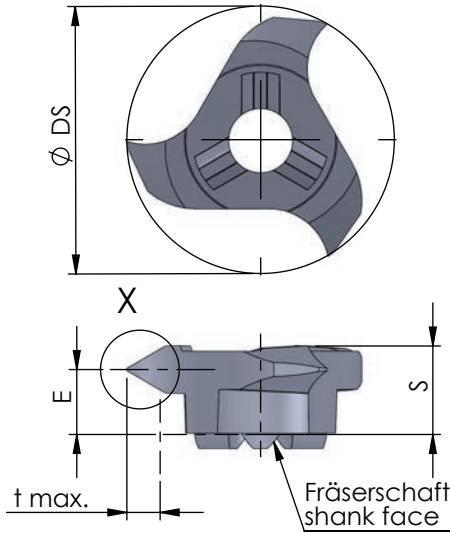

Beispielzeichnung
exemplary application

Abmessungen in mm

dimensions in mm

Bestellnummer part number	min. Gewindegröße min. thread size	Steigung P pitch P	S	E	Ø DS	b	t max.	Zähnezahl number of teeth	K10F AL41F P18C	für Fräaserschaft for milling shank
Z12.0510.01	M14	1.0-1.75	3.6	2.8	11.7	0.13	1.08	3	●	ZH10...
Z12.0720.01	M14	1.0-2.0	3.6	2.8	11.7	0.13	1.25	3	●	
Z12.0815.01	M16	1.5-2.75	3.6	2.4	11.7	0.19	1.67	3	●	
Z12.2530.01	M16	2.0-3.0	3.6	2.2	11.7	0.25	1.78	3	●	

Weitere HM Sorten können Sie in der Sortenübersicht im Kapitel "Technische Hinweise" und der Preisliste finden.

Bestellbeispiel:
für Sorte AL41F:
Z12.0510.01/AL41F

More carbide grades you can find in the grades summary in the chapter "technical instructions" and in the price list.

order-example:
grade AL41F:
Z12.0510.01/AL41F

MINIMILL

Nut- und Formzirkularfräsen

groove milling by circular interpolation

Typ Z614

metrisches ISO-Gewinde, Teilprofil, innen

metric ISO-thread, partial profile, internal

ab Gewindegröße M16 x 1.0

starting at thread size M16 x 1.0

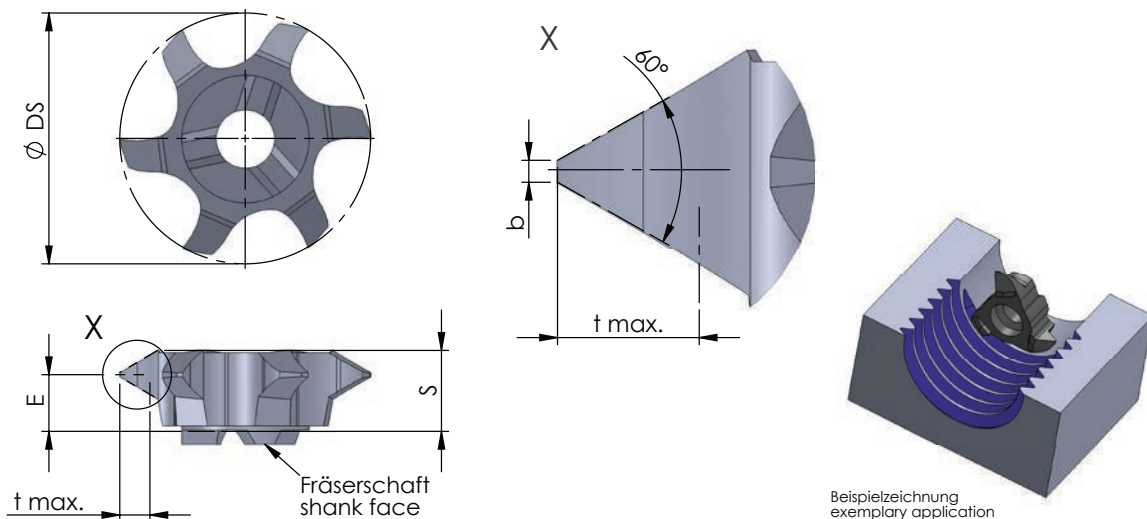

Abmessungen in mm

dimensions in mm

Bestellnummer part number	min. Gewindegröße min. thread size	Steigung P pitch P	S	E	Ø DS	b	t max.	Zähnezahl number of teeth	K10F AL41F P18C	für Fräseschaft for milling shank
Z614.0510.01	M16	1.0-1.75	4.2	3.4	12.0	0.13	1.08	6	●	ZH14...
Z614.0720.01	M16	1.0-2.0	4.2	3.6	12.3	0.13	1.25	6	●	
Z614.0815.01	M18	1.5-2.75	4.2	3.0	13.2	0.19	1.67	6	●	
Z614.2530.01	M18	2.0-3.0	4.2	2.8	13.3	0.25	1.78	6	●	

Weitere HM Sorten können Sie in der Sortenübersicht im Kapitel "Technische Hinweise" und der Preisliste finden.

Bestellbeispiel:
für Sorte AL41F:
Z614.0510.01/AL41F

More carbide grades you can find in the grades summary in the chapter "technical instructions" and in the price list.

order-example:
grade AL41F:
Z614.0510.01/AL41F

MINIMILL

Nut- und Formzirkularfräsen

groove milling by circular interpolation

Typ Z14

metrisches ISO-Gewinde, Vollprofil, innen

metric ISO-thread, full profile, internal

ab Gewindegröße M16 x 1.0

starting at thread size M16 x 1.0

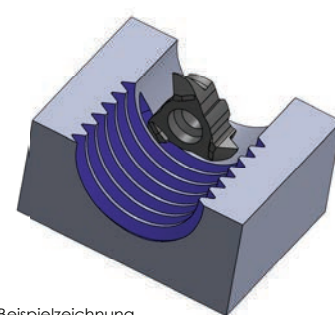
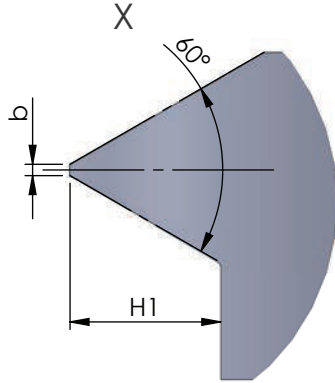
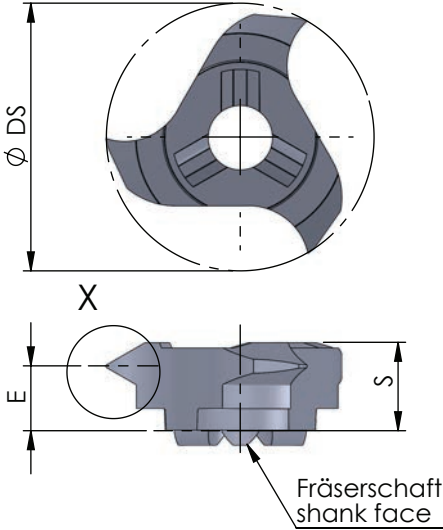

Beispielzeichnung
exemplary application

Abmessungen in mm

dimensions in mm

Bestellnummer part number	min. Gewindegröße min. thread size	Steigung P pitch P	S	E	$\varnothing DS$	b	H1	Zähnezahl number of teeth	K10F AL41F P18C	für Fräuserschaft for milling shank
Z14.0510.02	M16	1.00	4.5	3.6	13.7	0.13	0.54	3	●	ZH14...
Z14.0815.02	M18	1.50	4.5	3.5	13.7	0.19	0.81	3	●	
Z14.0917.02	M18	1.75	4.5	3.4	13.7	0.20	0.95	3	●	
Z14.1020.02	M18	2.00	4.5	3.3	13.7	0.25	1.08	3	●	
Z14.1325.02	M20	2.50	4.5	3.1	13.7	0.31	1.35	3	●	
Z14.1630.02	M22	3.00	4.5	2.9	13.7	0.37	1.62	3	●	

Weitere HM Sorten können Sie in der Sortenübersicht im Kapitel "Technische Hinweise" und der Preisliste finden.

Bestellbeispiel:
für Sorte AL41F:
Z14.0510.02/AL41F

More carbide grades you can find in the grades summary in the chapter "technical instructions" and in the price list.

order-example:
grade AL41F:
Z14.0510.02/AL41F

MINIMILL

Nut- und Formzirkularfräsen

groove milling by circular interpolation

Typ Z16

metrisches ISO-Gewinde, Teilprofil, innen

metric ISO-thread, partial profile, internal

ab Gewindegröße M18 x 1.0

starting at thread size M18 x 1.0

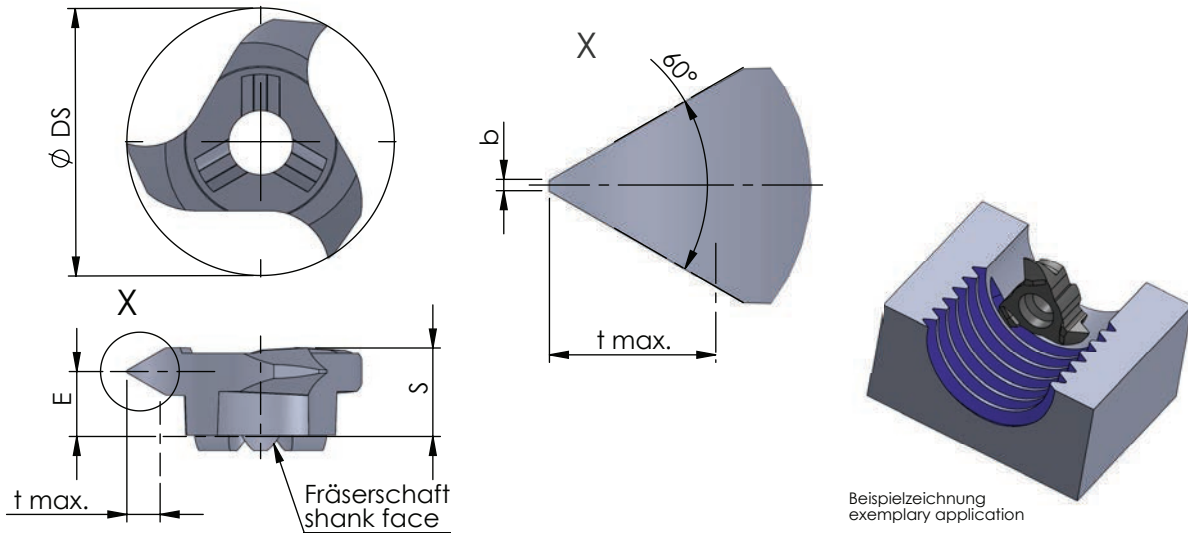

Abmessungen in mm

dimensions in mm

Bestellnummer part number	min. Gewindegröße min. thread size	Steigung P pitch P	S	E	$\varnothing DS$	b	t max.	Zähnezahl number of teeth	K10F AL41F P18C	für Fräaserschaft for milling shank
Z16.0510.01	M18	1.0-1.75	4.6	3.8	15.7	0.12	1.08	3	●	ZH14...
Z16.0720.01	M18	1.0-2.0	4.6	3.5	15.7	0.12	1.25	3	●	
Z16.0815.01	M20	1.5-2.75	4.6	3.5	15.7	0.19	1.67	3	●	
Z16.2530.01	M22	2.5-3.0	4.6	3.4	15.7	0.31	1.78	3	●	

Weitere HM Sorten können Sie in der Sortenübersicht im Kapitel "Technische Hinweise" und der Preisliste finden.

Bestellbeispiel:
für Sorte AL41F:
Z16.0510.01/AL41F

More carbide grades you can find in the grades summary in the chapter "technical instructions" and in the price list.

order-example:
grade AL41F:
Z16.0510.01/AL41F

MINIMILL

Nut- und Formzirkularfräsen

groove milling by circular interpolation

Typ Z18

metrisches ISO-Gewinde, Teilprofil, innen

metric ISO-thread, partial profile, internal

ab Gewindegröße M22 x 1.0

starting at thread size M22 x 1.0

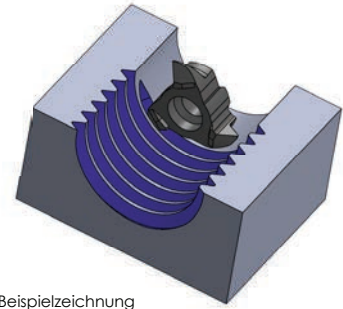
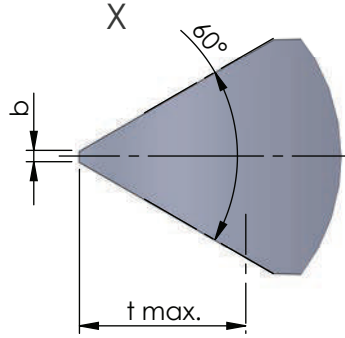
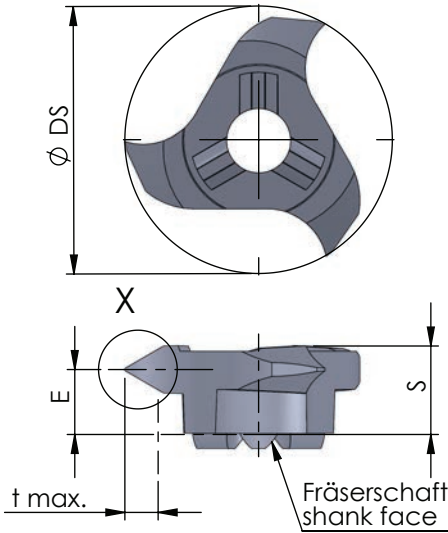

Beispielzeichnung
exemplary application

Abmessungen in mm

dimensions in mm

Bestellnummer part number	min. Gewindegröße min. thread size	Steigung P pitch P	S	E	Ø DS	b	t max.	Zähnezahl number of teeth	K10F AL41F P18C	für Frälerschaft for milling shank
Z18.0510.01	M22	1.0-1.75	5.85	5.0	17.7	0.12	1.03	3	●	ZH18...
Z18.0720.01	M22	1.0-2.0	5.85	4.7	17.7	0.12	1.19	3	●	
Z18.0815.01	M22	1.5-2.75	5.85	4.6	17.7	0.19	1.62	3	●	
Z18.1020.01	M24	2.0-3.75	5.85	4.2	17.7	0.25	2.22	3	●	
Z18.1325.01	M24	2.0-3.0	5.85	4.4	17.7	0.25	1.73	3	●	
Z18.1630.01	M24	2.5-5.0	5.85	3.8	17.7	0.31	2.98	3	●	
Z18.1835.01	M24	3.0-5.5	5.85	3.6	17.7	0.38	3.25	3	●	
Z18.2535.01	M24	2.0-3.5	5.85	4.2	17.7	0.25	2.06	3	●	

Weitere HM Sorten können Sie in der Sortenübersicht im Kapitel "Technische Hinweise" und der Preisliste finden.

Bestellbeispiel:
für Sorte AL41F:
Z18.0510.01/AL41F

More carbide grades you can find in the grades summary in the chapter "technical instructions" and in the price list.

order-example:
grade AL41F:
Z18.0510.01/AL41F

MINIMILL

Nut- und Formzirkularfräsen

groove milling by circular interpolation

Typ Z618

metrisches ISO-Gewinde, Teilprofil, innen

metric ISO-thread, partial profile, internal

ab Gewindegröße M22 x 1.0

starting at thread size M22 x 1.0

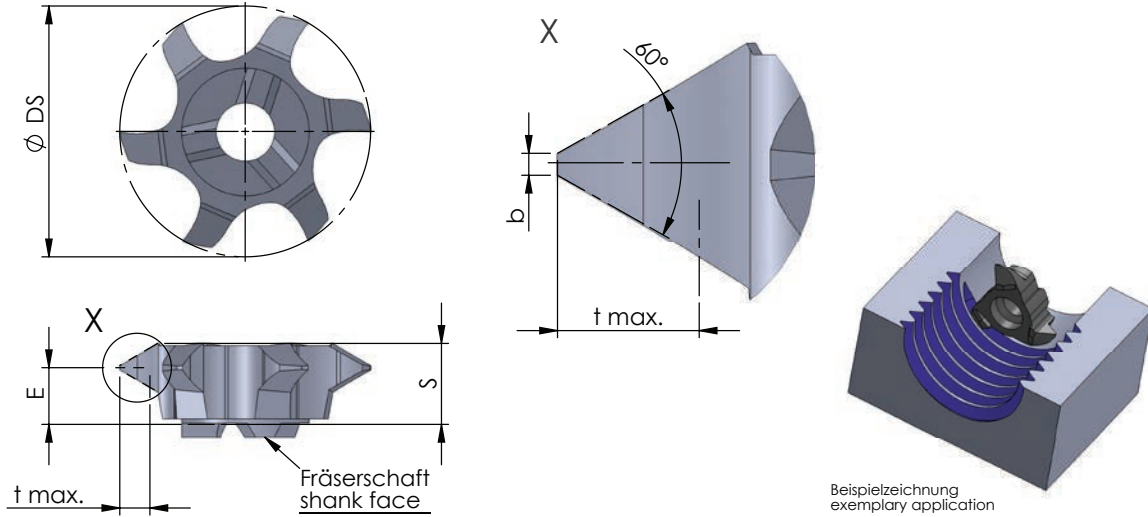

Abmessungen in mm

dimensions in mm

Bestellnummer part number	min. Gewindegröße min. thread size	Steigung P pitch P	S	E	$\varnothing DS$	b	t max.	Zähnezahl number of teeth	K10F AL41F P18C	für Fräaserschaft for milling shank
Z618.0720.01	M22	1.0-2.0	5.85	4.6	17.7	0.12	1.19	6	●	ZH18...
Z618.2545.01	M24	2.0-3.5	5.85	4.0	17.7	0.25	2.57	6	●	

Weitere HM Sorten können Sie in der Sortenübersicht im Kapitel "Technische Hinweise" und der Preisliste finden.

Bestellbeispiel:
für Sorte AL41F:
Z618.0720.01/AL41F

More carbide grades you can find in the grades summary in the chapter "technical instructions" and in the price list.

order-example:
grade AL41F:
Z618.0720.01/AL41F

MINIMILL

Nut- und Formzirkularfräsen

groove milling by circular interpolation

Typ Z18

metrisches ISO-Gewinde, Vollprofil, innen

metric ISO-thread, full profile, internal

ab Gewindegröße M22 x 1,5

starting at thread size M22 x 1,5

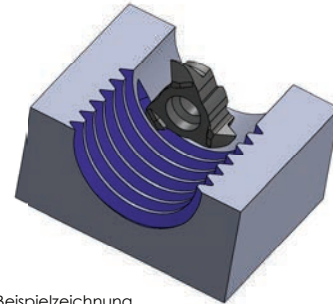
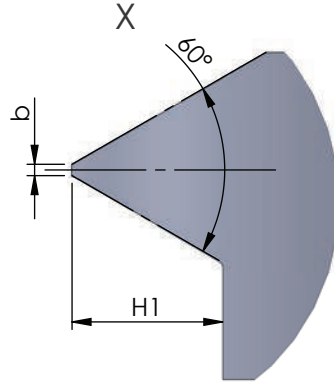
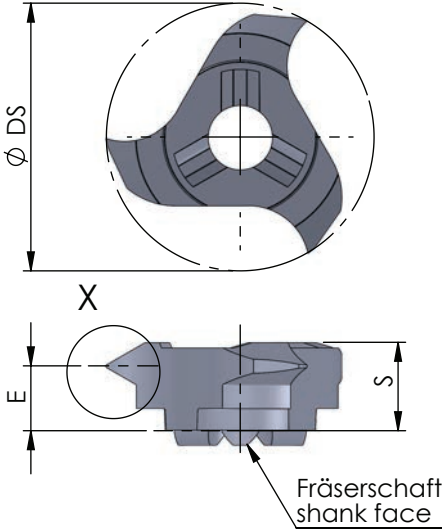

Beispielzeichnung
exemplary application

Abmessungen in mm

dimensions in mm

Bestellnummer part number	min. Gewindegröße min. thread size	Steigung P pitch P	S	E	Ø DS	b	H1	Zähnezahl number of teeth	K10F AL41F P18C	für Fräseschaft for milling shank
Z18.0815.02	M22	1.50	5.85	4.8	17.7	0.18	0.81	3	●	ZH18...
Z18.0917.02	M22	1.75	5.85	4.7	17.7	0.20	0.95	3	●	
Z18.1020.02	M22	2.00	5.85	4.6	17.7	0.25	1.08	3	●	
Z18.1325.02	M24	2.50	5.85	4.4	17.7	0.31	1.35	3	●	
Z18.1630.02	M27	3.00	5.85	4.3	17.7	0.37	1.62	3	●	
Z18.1835.02	M27	3.50	5.85	4.0	17.7	0.43	1.895	3	●	

Weitere HM Sorten können Sie in der Sortenübersicht im Kapitel "Technische Hinweise" und der Preisliste finden.

Bestellbeispiel:
für Sorte AL41F:
Z18.0815.02/AL41F

More carbide grades you can find in the grades summary in the chapter "technical instructions" and in the price list.

order-example:
grade AL41F:
Z18.0815.02/AL41F

MINIMILL

Nut- und Formzirkularfräsen

groove milling by circular interpolation

Typ Z618

metrisches ISO-Gewinde, Vollprofil, innen

metric ISO-thread, full profile, internal

ab Gewindegröße M22 x 1,5

starting at thread size M22 x 1,5

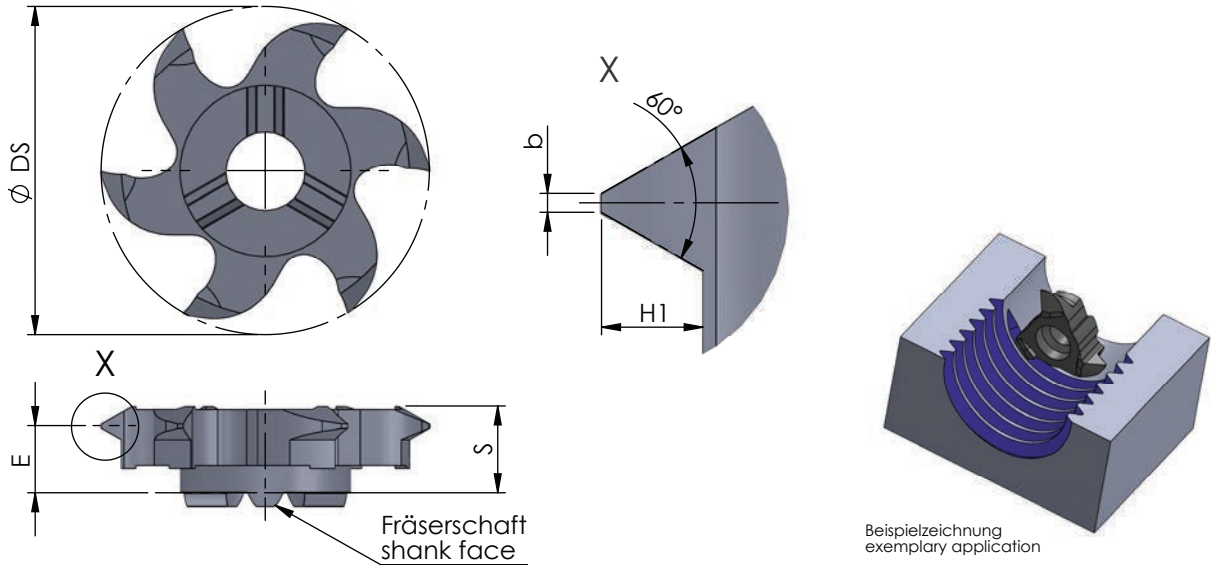

Abmessungen in mm

dimensions in mm

	Bestellnummer part number	min. Gewindegröße min. thread size	Steigung P pitch P	S	E	Ø DS	b	H1	Zähnezahl number of teeth	K10F AL41F P18C	für Fräterschaft for milling shank
neu	Z618.0815.02	M22	1.50	5.85	5.0	17.7	0.19	0.81	6	●	ZH18...
neu	Z618.1020.02	M22	2.00	5.85	4.8	17.7	0.25	1.083	6	●	
neu	Z618.1630.02	M27	3.00	5.85	4.6	17.7	0.38	1.62	6	●	
neu	Z618.1835.02	M27	3.50	5.85	4.0	17.7	0.44	1.89	6	●	

Weitere HM Sorten können Sie in der Sortenübersicht im Kapitel "Technische Hinweise" und der Preisliste finden.

Bestellbeispiel:
für Sorte AL41F:
Z618.0815.02/AL41F

More carbide grades you can find in the grades summary in the chapter "technical instructions" and in the price list.

order-example:
grade AL41F:
Z618.0815.02/AL41F



MINIMILL

Nut- und Formzirkularfräsen

groove milling by circular interpolation

Typ Z22

metrisches ISO-Gewinde, Teilprofil, innen

metric ISO-thread, partial profile, internal

ab Gewindegröße M27 x 1,0

starting at thread size M27 x 1,0

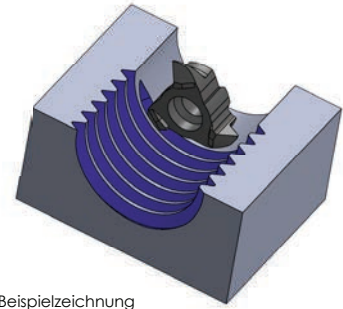
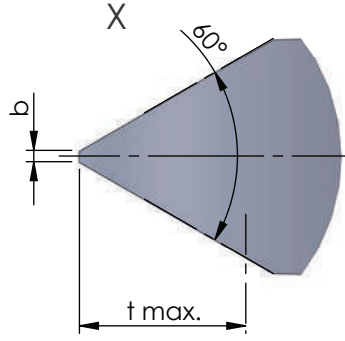
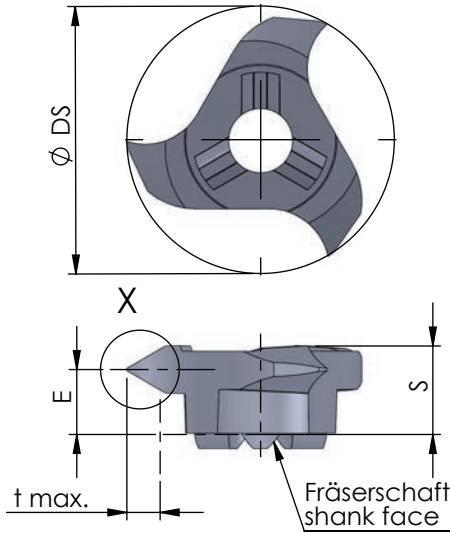

Beispielzeichnung
exemplary application

Abmessungen in mm

dimensions in mm

Bestellnummer part number	min. Gewindegröße min. thread size	Steigung P pitch P	S	E	Ø DS	b	t max.	Zähnezahl number of teeth	K10F AL41F P18C	für Frärschaft for milling shank
Z22.0720.01	M27	1.0-2.0	5.85	4.6	21.7	0.12	1.19	3	●	ZH22...
Z22.0815.01	M27	1.5-2.75	5.85	4.5	21.7	0.18	1.62	3	●	
Z22.1020.01	M27	2.0-3.75	5.85	4.2	21.7	0.25	2.22	3	●	
Z22.1630.01	M30	2.5-5.0	5.85	3.8	21.7	0.31	2.98	3	●	
Z22.2140.01	M30	3.5-6.0	5.85	3.4	21.7	0.44	3.52	3	●	
Z22.2445.01	M30	3.5-6.5	5.85	3.2	21.7	0.44	3.84	3	●	
Z22.2545.01	M27	2.5-4.5	5.85	3.7	21.7	0.31	2.70	3	●	

Weitere HM Sorten können Sie in der Sortenübersicht im Kapitel "Technische Hinweise" und der Preisliste finden.

Bestellbeispiel:
für Sorte AL41F:
Z22.0720.01/AL41F

More carbide grades you can find in the grades summary in the chapter "technical instructions" and in the price list.

order-example:
grade AL41F:
Z22.0720.01/AL41F

MINIMILL

Nut- und Formzirkularfräsen

groove milling by circular interpolation

Typ Z622

metrisches ISO-Gewinde, Teilprofil, innen

metric ISO-thread, partial profile, internal

ab Gewindegröße M27 x 1,0

starting at thread size M27 x 1,0

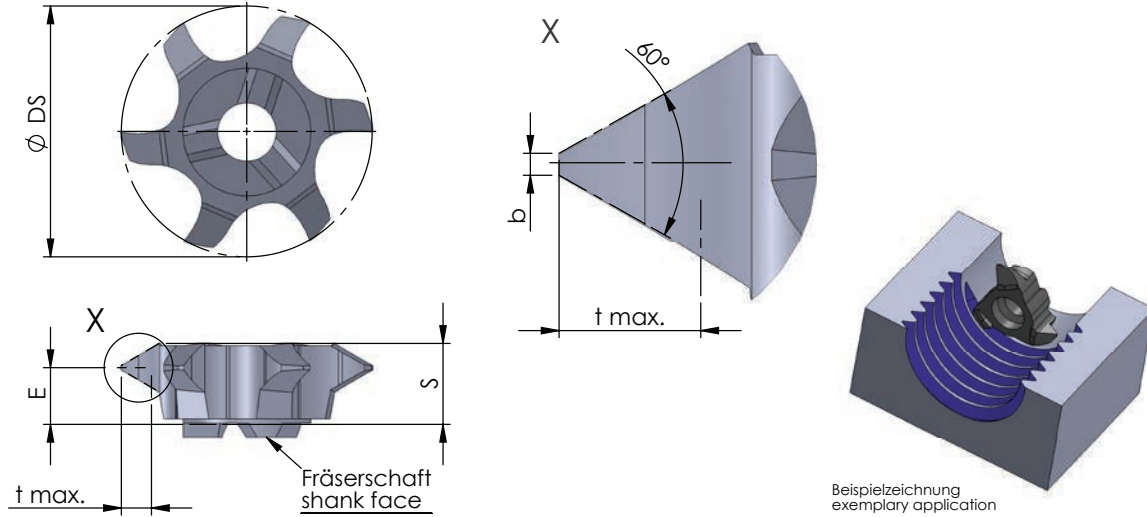

Abmessungen in mm

dimensions in mm

Bestellnummer part number	min. Gewindegröße min. thread size	Steigung P pitch P	S	E	$\varnothing DS$	b	t max.	Zähnezahl number of teeth	K10F AL41F P18C	für Fräseschaft for milling shank
Z622.0720.01	M27	1.0-2.0	6.2	5.0	21.7	0.12	1.19	6	●	
Z622.2545.01	M27	2.0-4.5	6.05	4.2	21.7	0.25	2.7	6	●	ZH22...

Weitere HM Sorten können Sie in der Sortenübersicht im Kapitel "Technische Hinweise" und der Preisliste finden.

Bestellbeispiel:
für Sorte AL41F:
Z622.0720.01/AL41F

More carbide grades you can find in the grades summary in the chapter "technical instructions" and in the price list.

order-example:
grade AL41F:
Z622.0720.01/AL41F

MINIMILL

Nut- und Formzirkularfräsen

groove milling by circular interpolation

Typ Z22

metrisches ISO-Gewinde, Vollprofil, innen

metric ISO-thread, full profile, internal

ab Gewindegröße M24 x 1,5

starting at thread size M24 x 1,5

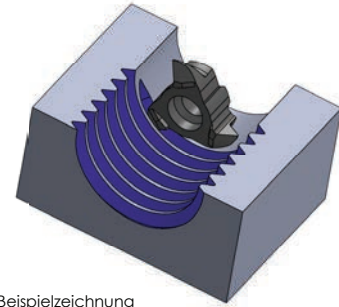
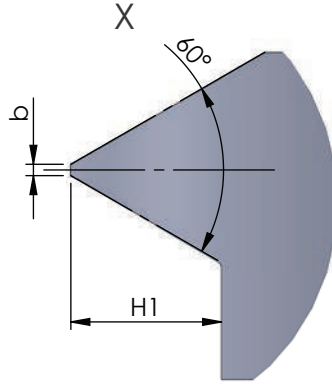
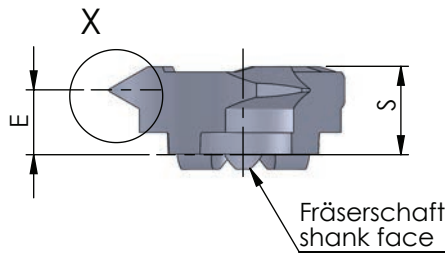
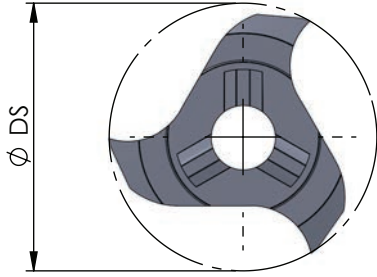

Beispielzeichnung
exemplary application

Abmessungen in mm

dimensions in mm

Bestellnummer part number	min. Gewindegröße min. thread size	Steigung P pitch P	S	E	Ø DS	b	H1	Zähnezahl number of teeth	K10F AL41F P18C	für Fräseschaft for milling shank
Z22.0815.02	M24	1.50	5.85	4.8	21.7	0.19	0.81	3	●	ZH22...
Z22.0917.02	M27	1.75	5.85	4.7	21.7	0.22	0.95	3	●	
Z22.1020.02	M27	2.00	5.85	4.6	21.7	0.25	1.08	3	●	
Z22.1630.02	M30	3.00	5.85	4.3	21.7	0.37	1.62	3	●	
Z22.1835.02	M30	3.50	5.85	4.0	21.7	0.43	1.89	3	●	
Z22.2140.02	M33	4.00	5.85	3.9	21.7	0.50	2.16	3	●	
Z22.2445.02	M33	4.50	5.85	3.7	21.7	0.56	2.43	3	●	

Weitere HM Sorten können Sie in der Sortenübersicht im Kapitel "Technische Hinweise" und der Preisliste finden.

Bestellbeispiel:
für Sorte AL41F:
Z22.0815.02/AL41F

More carbide grades you can find in the grades summary in the chapter "technical instructions" and in the price list.

order-example:
grade AL41F:
Z22.0815.02/AL41F

MINIMILL

Nut- und Formzirkularfräsen

groove milling by circular interpolation

Typ Z622

metrisches ISO-Gewinde, Vollprofil, innen

metric ISO-thread, full profile, internal

ab Gewindegröße M24 x 1,5

starting at thread size M24 x 1,5

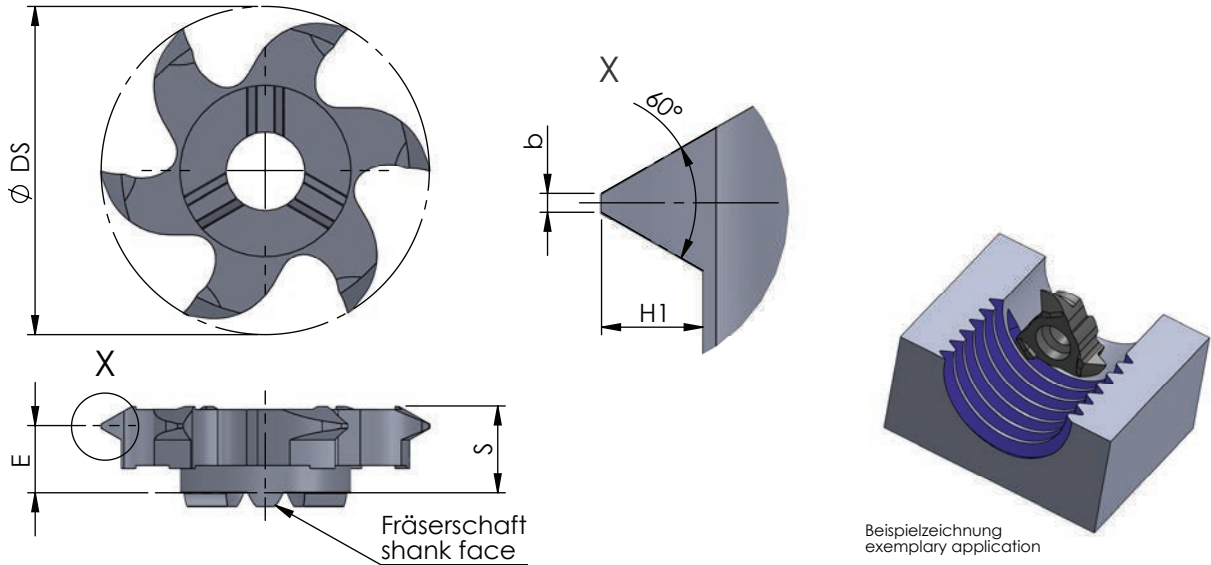

Abmessungen in mm

dimensions in mm

Bestellnummer part number	min. Gewindegröße min. thread size	Steigung P pitch P	S	E	$\varnothing DS$	b	H1	Zähnezahl number of teeth	K10F AL41F P18C	für Fräterschaft for milling shank
Z622.0815.02	M24	1.50	6.2	5.3	21.7	0.19	0.81	6	●	ZH22...
Z622.0917.02	M27	1.75	6.2	5.2	21.7	0.22	0.95	6	●	
Z622.1020.02	M27	2.00	6.2	5.0	21.7	0.25	1.08	6	●	
Z622.1630.02	M30	3.00	6.2	4.8	21.7	0.37	1.62	6	●	
Z622.2140.02	M33	4.00	6.2	4.4	21.7	0.50	2.16	6	●	

Weitere HM Sorten können Sie in der Sortenübersicht im Kapitel "Technische Hinweise" und der Preisliste finden.

Bestellbeispiel:
für Sorte AL41F:
Z622.0815.02/AL41F

More carbide grades you can find in the grades summary in the chapter "technical instructions" and in the price list.

order-example:
grade AL41F:
Z622.0815.02/AL41F

MINIMILL

Nut- und Formzirkularfräsen

groove milling by circular interpolation

Typ Z28

metrisches ISO-Gewinde, Teilprofil, innen

metric ISO-thread, partial profile, internal

ab Gewindegröße M33 x 1,0

starting at thread size M33 x 1,0

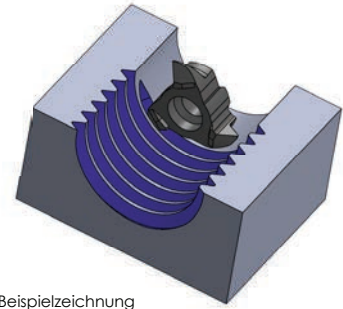
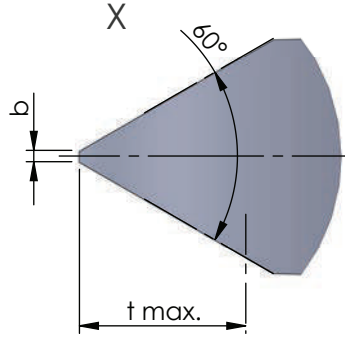
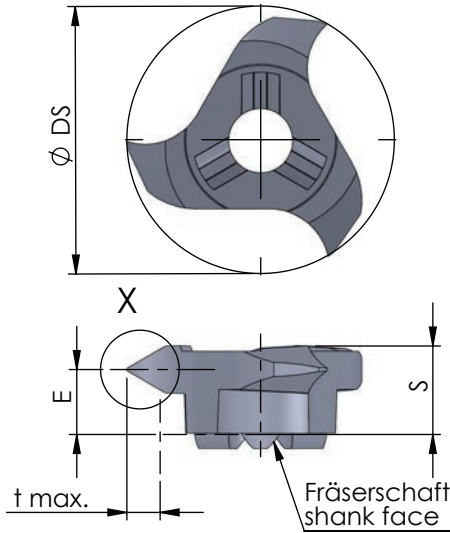

Beispielzeichnung
exemplary application

Abmessungen in mm

dimensions in mm

Bestellnummer part number	min. Gewindegröße min. thread size	Steigung P pitch P	S	E	Ø DS	b	t max.	Zähnezahl number of teeth	K10F AL41F P18C	für Fräaserschaft for milling shank
Z28.0720.01	M33	1.0-2.0	6.6	4.6	27.7	0.12	1.20	3	●	ZH28...
Z28.1525.01	M33	1.5-2.5	6.6	4.3	27.7	0.18	1.49	3	●	
Z28.3050.01	M36	2.5-5.0	6.6	4.0	27.7	0.37	2.93	3	●	
Z28.5060.01	M39	4.0-6.0	6.6	3.6	27.7	0.50	4.60	3	●	

Weitere HM Sorten können Sie in der Sortenübersicht im Kapitel "Technische Hinweise" und der Preisliste finden.

Bestellbeispiel:
für Sorte AL41F:
Z28.0720.01/AL41F

More carbide grades you can find in the grades summary in the chapter "technical instructions" and in the price list.

order-example:
grade AL41F:
Z28.0720.01/AL41F

MINIMILL

Nut- und Formzirkularfräsen

groove milling by circular interpolation

Typ Z628

metrisches ISO-Gewinde, Teilprofil, innen

metric ISO-thread, partial profile, internal

ab Gewindegröße M33 x 1,5

starting at thread size M33 x 1,5

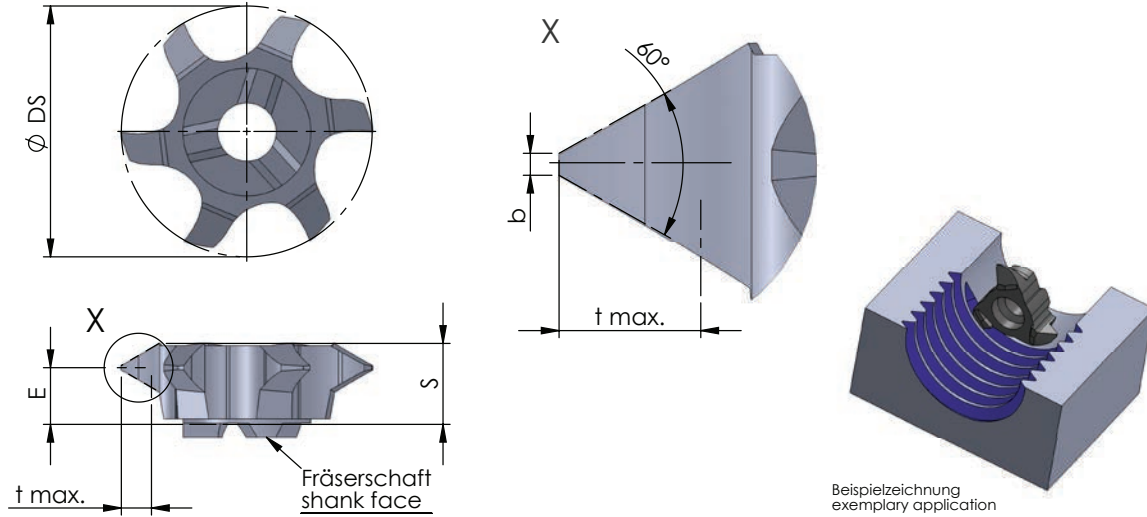

Abmessungen in mm

dimensions in mm

Bestellnummer part number	min. Gewindegröße min. thread size	Steigung P pitch P	S	E	$\varnothing DS$	b	t max.	Zähnezahl number of teeth	K10F AL41F P18C	für Fräterschaft for milling shank
Z628.1525.01	M33	1.5-2.5	6.5	5.0	27.7	0.19	1.6	6	●	ZH28...
Z628.3050.01	M36	2.5-5.0	6.1	3.9	27.7	0.38	2.93	6	●	

Weitere HM Sorten können Sie in der Sortenübersicht im Kapitel "Technische Hinweise" und der Preisliste finden.

Bestellbeispiel:
für Sorte AL41F:
Z628.1525.01/AL41F

More carbide grades you can find in the grades summary in the chapter "technical instructions" and in the price list.

order-example:
grade AL41F:
Z628.1525.01/AL41F

MINIMILL

Nut- und Formzirkularfräsen

groove milling by circular interpolation

Typ Z622

metrisches ISO-Gewinde, Vollprofil, außen

metric ISO-thread, full profile, external

Steigung 1.5 - 4.0

pitch 1.5 - 4.0

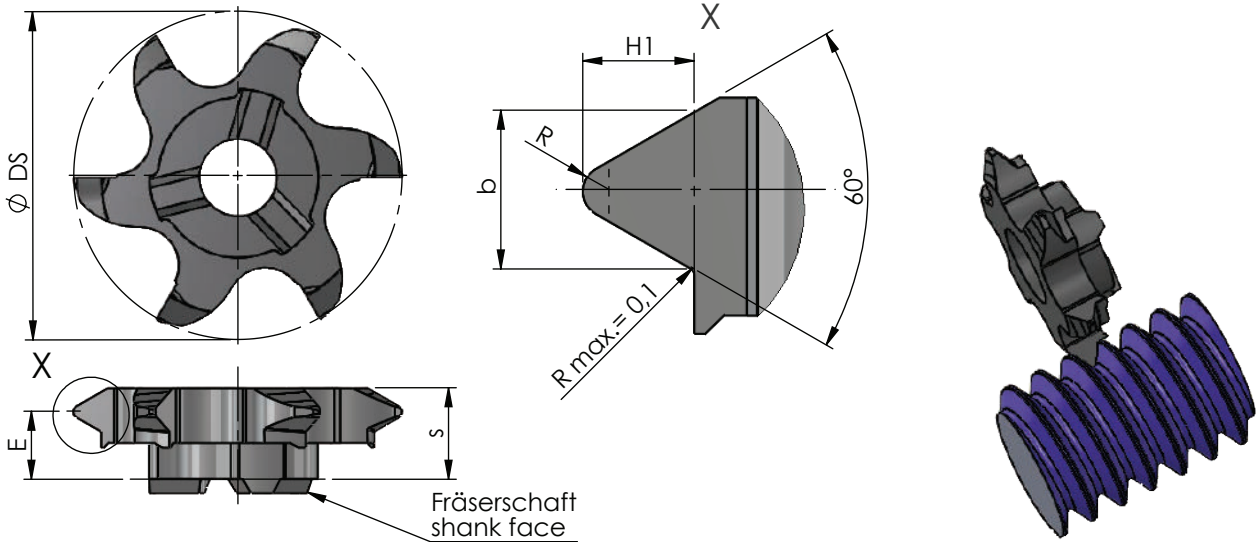

Abmessungen in mm

dimensions in mm

Bestellnummer part number	Steigung P pitch P	S	E	R	Ø DS	b ± 0.01	H1	Zähnezahl number of teeth	K10F AL41F P18C	für Frälerschaft for milling shank
Z622.E0815.02	1.50	6.25	5.35	0.22	21.7	1.316	0.92	6	●	ZH22...
Z622.E0917.02	1.75	6.25	5.25	0.25	21.7	1.524	1.07	6	●	
Z622.E1020.02	2.00	6.25	5.10	0.29	21.7	1.755	1.23	6	●	
Z622.E1630.02	3.00	6.05	4.50	0.43	21.7	2.621	1.84	6	●	
Z622.E2140.02	4.00	6.05	4.00	0.58	21.7	3.499	2.45	6	●	

Weitere HM Sorten können Sie in der Sortenübersicht im Kapitel "Technische Hinweise" und der Preisliste finden.

Bestellbeispiel:
für Sorte AL41F:
Z622.E0815.02/AL41F

More carbide grades you can find in the grades summary in the chapter "technical instructions" and in the price list.

order-example:
grade AL41F:
Z622.E0815.02/AL41F

MINIMILL

Nut- und Formzirkularfräsen

groove milling by circular interpolation

Typ Z12

Whitworth-Gewinde, Vollprofil, innen

Whitworth thread, full profile, internal

ab Gewindegröße G 3/8"

starting at thread size G 3/8"

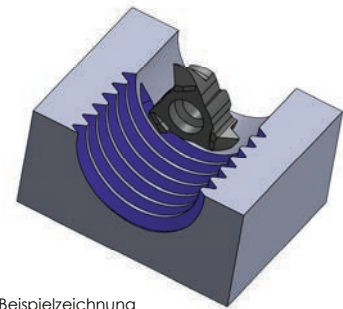
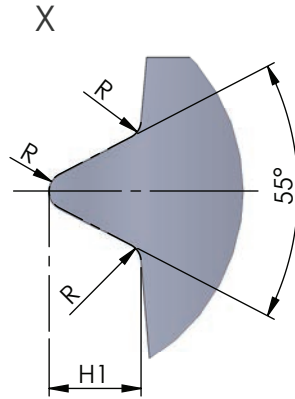
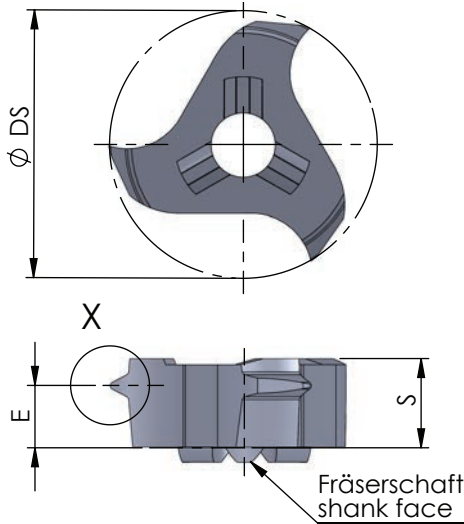

Beispielzeichnung
exemplary application

Abmessungen in mm

dimensions in mm

Bestellnummer part number	min. Gewindegröße min. thread size	Gang / Zoll threads / inch	S	E	Ø DS	H1	R	Zähnezahl number of teeth				für Frälerschaft for milling shank
									K10F	AL41F	P18C	
Z12.0813.19	G 3/8"	19	3.6	2.5	11.7	0.86	0.18	3	●			
Z12.1118.14	G 1/2"	14	3.6	2.3	11.7	1.16	0.24	3	●			ZH10...
Z12.1423.11	G 1"	11	3.6	2.0	11.7	1.48	0.31	3	●			

Weitere HM Sorten können Sie in der Sortenübersicht im Kapitel "Technische Hinweise" und der Preisliste finden.

Bestellbeispiel:
für Sorte AL41F:
Z12.1423.11/AL41F

More carbide grades you can find in the grades summary in the chapter "technical instructions" and in the price list.

order-example:
grade AL41F:
Z12.1423.11/AL41F

MINIMILL

Nut- und Formzirkularfräsen

groove milling by circular interpolation

Typ Z614

Whitworth-Gewinde, Vollprofil, innen

Whitworth thread, full profile, internal

ab Gewindegröße G 3/4"

starting at thread size G 3/4"

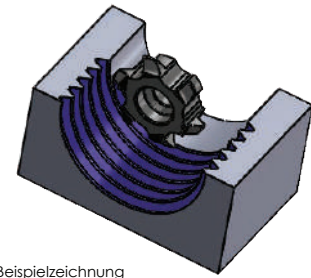
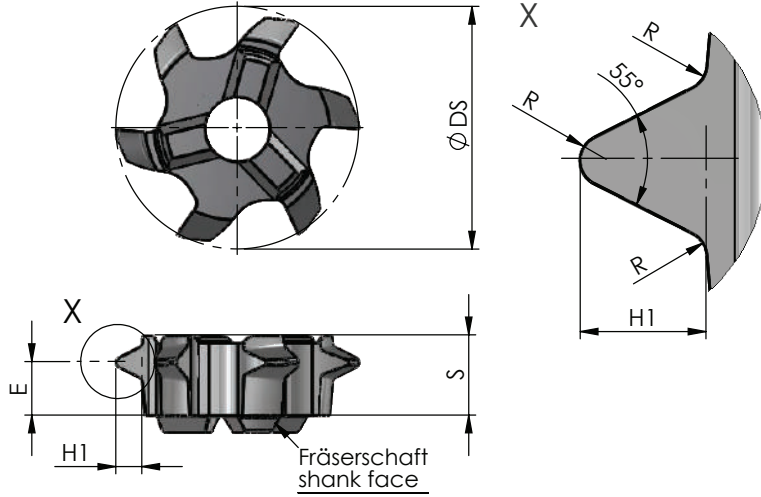

Beispielzeichnung
exemplary application

Abmessungen in mm

dimensions in mm

Bestellnummer part number	min. Gewindegröße min. thread size	Gang / Zoll threads / inch	S	E	$\varnothing DS$	H1	R	Zähnezahl number of teeth				für Fräaserschaft for milling shank
									K10F	AL41F	P18C	
Z614.5514.02	G 3/4"	14	4.6	3.3	13.7	1.16	0.24	6	●			
Z614.5511.02	G 1"	11	4.6	3.1	13.7	1.48	0.31	6	●			ZH14...

Weitere HM Sorten können Sie in der Sortenübersicht im Kapitel "Technische Hinweise" und der Preisliste finden.

Bestellbeispiel:
für Sorte AL41F:
Z614.5514.02/AL41F

More carbide grades you can find in the grades summary in the chapter "technical instructions" and in the price list.

order-example:
grade AL41F:
Z614.5514.02/AL41F

MINIMILL

Nut- und Formzirkularfräsen

groove milling by circular interpolation

Typ Z16

Whitworth-Gewinde, Vollprofil, innen

Whitworth thread, full profile, internal

ab Gewindegröße G 5/8"

starting at thread size G 5/8"

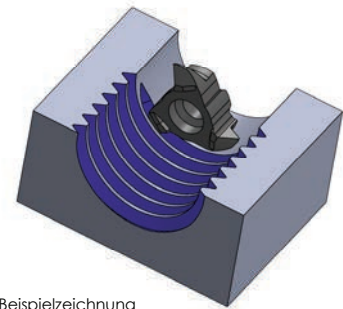
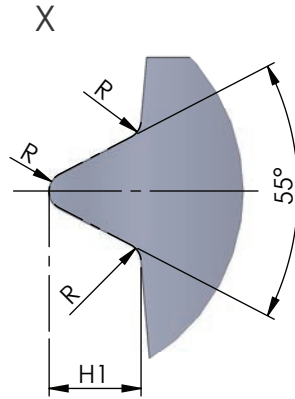
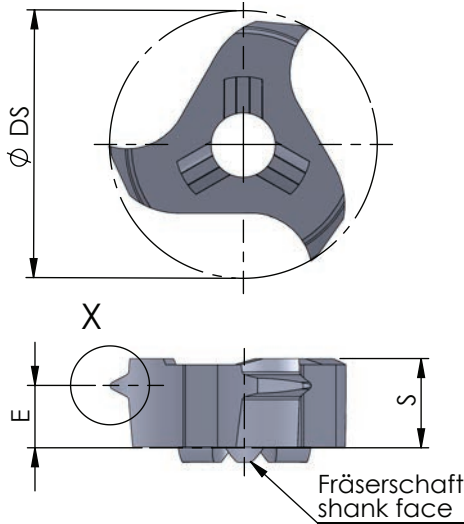

Beispielzeichnung
exemplary application

Abmessungen in mm

dimensions in mm

neu
neu

Bestellnummer part number	min. Gewindegröße min. thread size	Gang / Zoll threads / inch	S	E	Ø DS	H1	R	Zähnezahl number of teeth	K10F AL41F P18C	für Frälerschaft for milling shank
Z16.5514.02	G 5/8"	14	4.5	3.0	15.7	1.17	0.24	3	●	
Z16.5511.02	G 1"	11	4.5	2.8	15.7	1.48	0.31	3	●	ZH14...

Weitere HM Sorten können Sie in der Sortenübersicht im Kapitel "Technische Hinweise" und der Preisliste finden.

Bestellbeispiel:
für Sorte AL41F:
Z16.5514.02/AL41F

More carbide grades you can find in the grades summary in the chapter "technical instructions" and in the price list.

order-example:
grade AL41F:
Z16.5514.02/AL41F

MINIMILL

Nut- und Formzirkularfräsen

groove milling by circular interpolation

Typ Z18

Whitworth-Gewinde,
Vollprofil, innen

Whitworth thread,
full profile, internal

ab Gewindegröße G 3/4"

starting at thread size G 3/4"

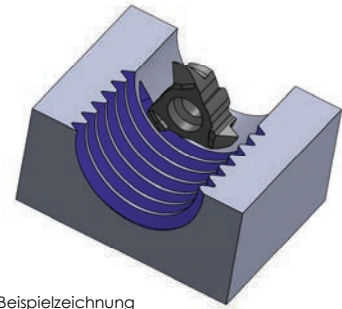
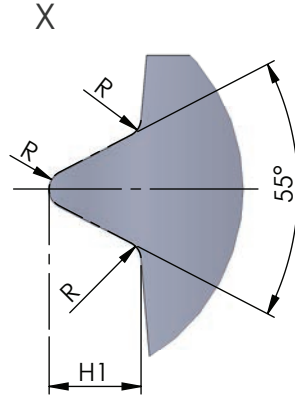
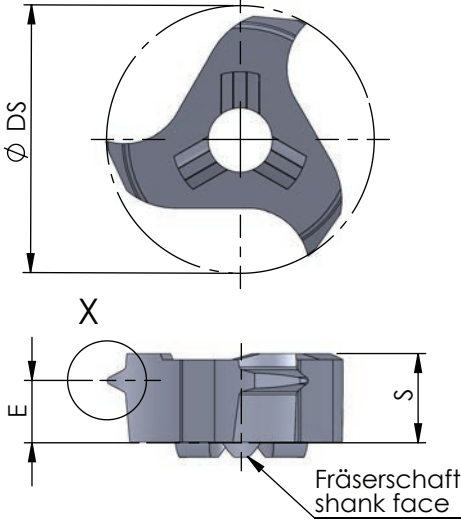

Beispielzeichnung
exemplary application

Abmessungen in mm

dimensions in mm

Bestellnummer part number	min. Gewindegröße min. thread size	Gang / Zoll threads / inch	S	E	Ø DS	H1	R	Zähnezahl number of teeth	K10F AL41F P18C	für Frärschaft for milling shank
Z18.5511.02	G 1"	11	5.85	4.4	17.7	1.48	0.32	3	●	
Z18.5514.02	G ¾"	14	5.85	4.6	17.7	1.16	0.25	3	●	ZH18...
Z18.5519.02	-	19	5.85	4.9	17.7	0.857	0.18	3	●	

Weitere HM Sorten können Sie in der Sortenübersicht im Kapitel "Technische Hinweise" und der Preisliste finden.

Bestellbeispiel:
für Sorte AL41F:
Z18.5519.02/AL41F

More carbide grades you can find in the grades summary in the chapter "technical instructions" and in the price list.

order-example:
grade AL41F:
Z18.5519.02/AL41F

MINIMILL

Nut- und Formzirkularfräsen

groove milling by circular interpolation

Typ Z22

Whitworth-Gewinde, Vollprofil, innen

Whitworth thread, full profile, internal

ab Gewindegröße G 1"

starting at thread size G 1"

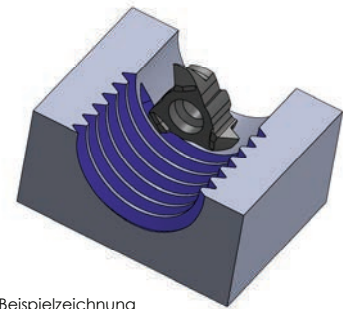
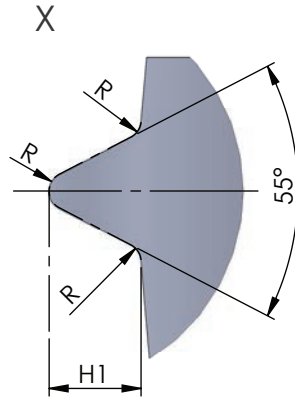
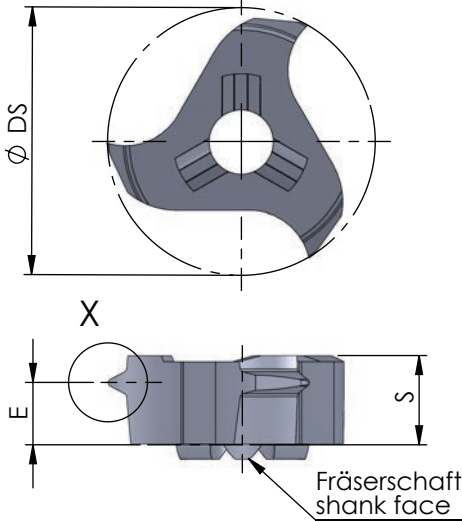

Beispielzeichnung
exemplary application

Abmessungen in mm

dimensions in mm

Bestellnummer part number	min. Gewindegröße min. thread size	Gang / Zoll threads / inch	S	E	Ø DS	H1	R	Zähnezahl number of teeth				für Frärschaft for milling shank
									K10F	AL41F	P18C	
Z22.5506.02	BSW 1½"	6	5.85	3.1	21.7	2.71	0.58	3	●			
Z22.5508.02	-	8	5.85	3.5	21.7	2.03	0.43	3	●			ZH22...
Z22.5511.02	G 1"	11	5.85	4.0	21.7	1.48	0.31	3	●			

Weitere HM Sorten können Sie in der Sortenübersicht im Kapitel "Technische Hinweise" und der Preisliste finden.

Bestellbeispiel:
für Sorte AL41F:
Z22.5508.02/AL41F

More carbide grades you can find in the grades summary in the chapter "technical instructions" and in the price list.

order-example:
grade AL41F:
Z22.5508.02/AL41F

MINIMILL

Nut- und Formzirkularfräsen

groove milling by circular interpolation

Typ Z622

Whitworth-Gewinde, Vollprofil, innen

Whitworth thread, full profile, internal

ab Gewindegröße G 1"

starting at thread size G 1"

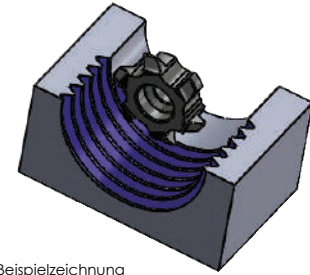
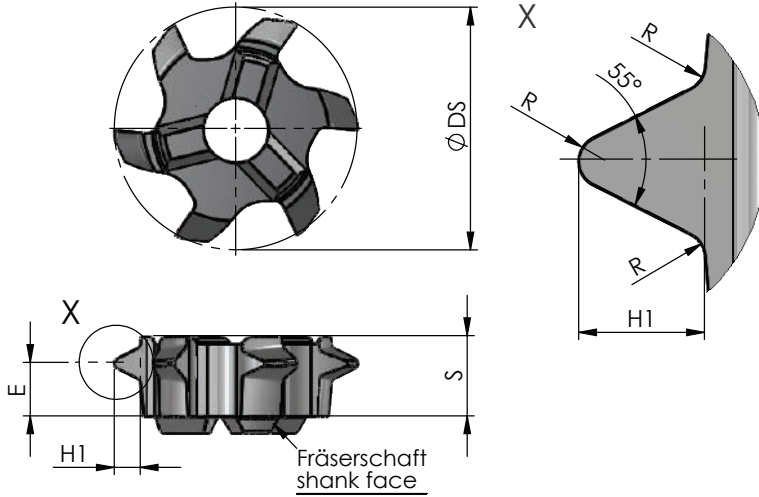

Beispielzeichnung
exemplary application

Abmessungen in mm

dimensions in mm

Bestellnummer part number	min. Gewindegröße min. thread size	Gang / Zoll threads / inch	S	E	$\varnothing DS$	H1	R	Zähnezahl number of teeth				für Fräterschaft for milling shank
									K10F	AL41F	P18C	
Z622.5506.02	BSW 1½"	6	6.05	3.8	21.7	2.71	0.58	6	●			
Z622.5508.02	-	8	6.31	4.2	21.7	2.03	0.43	6	●			ZH22...
Z622.5511.02	G 1"	11	6.35	4.8	21.7	1.48	0.31	6	●			

Weitere HM Sorten können Sie in der Sortenübersicht im Kapitel "Technische Hinweise" und der Preisliste finden.

Bestellbeispiel:
für Sorte AL41F:
Z622.5506.02/AL41F

More carbide grades you can find in the grades summary in the chapter "technical instructions" and in the price list.

order-example:
grade AL41F:
Z622.5506.02/AL41F

MINIMILL

Nut- und Formzirkularfräsen

groove milling by circular interpolation

Typ Z10 / Z12

Vorwärts- und Rückwärtsfasen

forward & backward chamfering

D min. 10 / 12 mm

D min. 10 / 12 mm

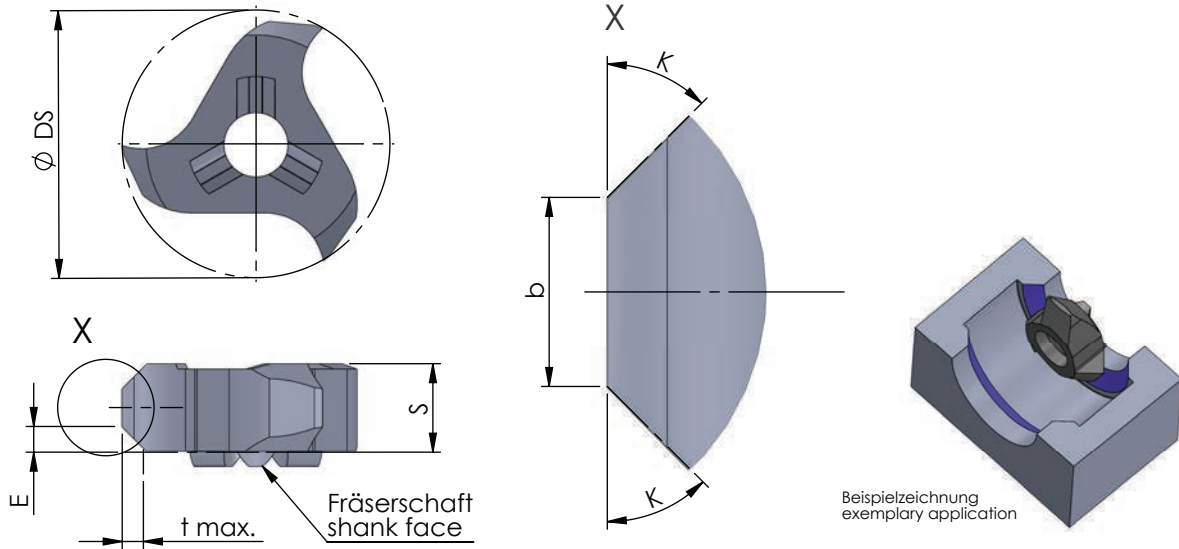

Beispielzeichnung
exemplary application

Abmessungen in mm

dimensions in mm

Bestellnummer part number	K	D min.	S	E	$\varnothing DS$	b	t max.	Zähnezahl number of teeth	K10F AL41F P18C	für Fräseschaft for milling shank
Z10.4545.35	45°	10	3.5	1.4	9.7	0.9	1.0	3	●	
Z12.4545.35	45°	12	3.5	1.2	11.7	1.2	0.8	3	●	ZH10...

Weitere HM Sorten können Sie in der Sortenübersicht im Kapitel "Technische Hinweise" und der Preisliste finden.

Bestellbeispiel:
für Sorte AL41F:
Z12.4545.35/AL41F

More carbide grades you can find in the grades summary in the chapter "technical instructions" and in the price list.

order-example:
grade AL41F:
Z12.4545.35/AL41F

MINIMILL

Nut- und Formzirkularfräsen

groove milling by circular interpolation

Typ Z610

Vorwärts- und Rückwärtsfasen

forward & backward chamfering

D min. 10 mm

D min. 10 mm

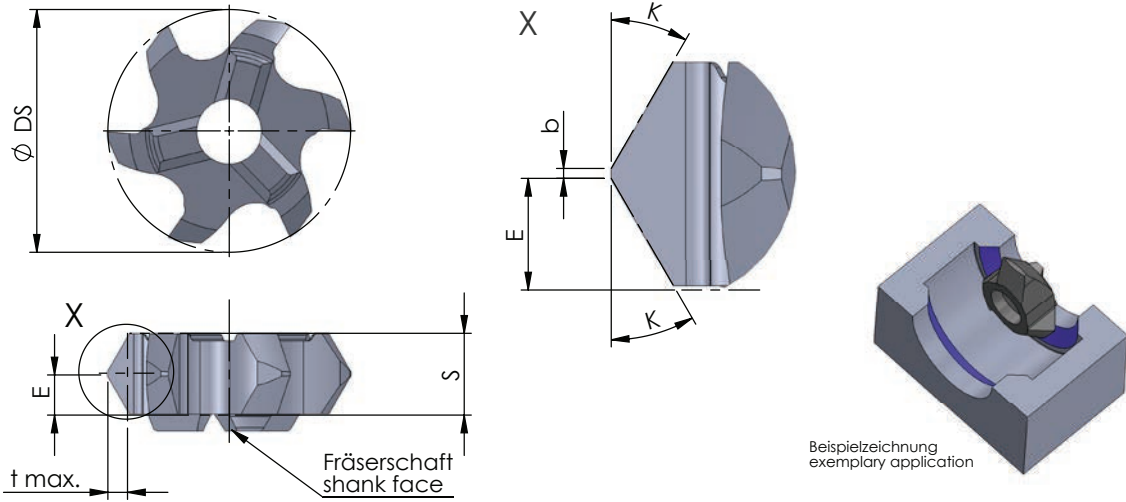

Abmessungen in mm

dimensions in mm

Bestellnummer part number	K	D min.	S	E	$\varnothing DS$	b	t max.	Zähnezahl number of teeth				für Fräseschaft for milling shank
									K10F	AL41F	P18C	
Z610.1515.02	15°	10	3.6	1.8	9.7	0.2	0.35	6	●			ZH10...
Z610.2020.02	20°	10	3.6	1.8	9.7	0.2	0.45	6	●			
Z610.3030.02	30°	10	3.6	1.8	9.7	0.2	0.7	6	●			
Z610.4545.02	45°	10	3.6	1.8	9.7	0.2	1.2	6	●			

Weitere HM Sorten können Sie in der Sortenübersicht im Kapitel "Technische Hinweise" und der Preisliste finden.

Bestellbeispiel:
für Sorte AL41F:
Z610.1515.02/AL41F

More carbide grades you can find in the grades summary in the chapter "technical instructions" and in the price list.

order-example:
grade AL41F:
Z610.1515.02/AL41F

MINIMILL

Nut- und Formzirkularfräsen

groove milling by circular interpolation

Typ Z614

Vorwärts- und Rückwärtsfasen

forward & backward chamfering

D min. 14 mm

D min. 14 mm

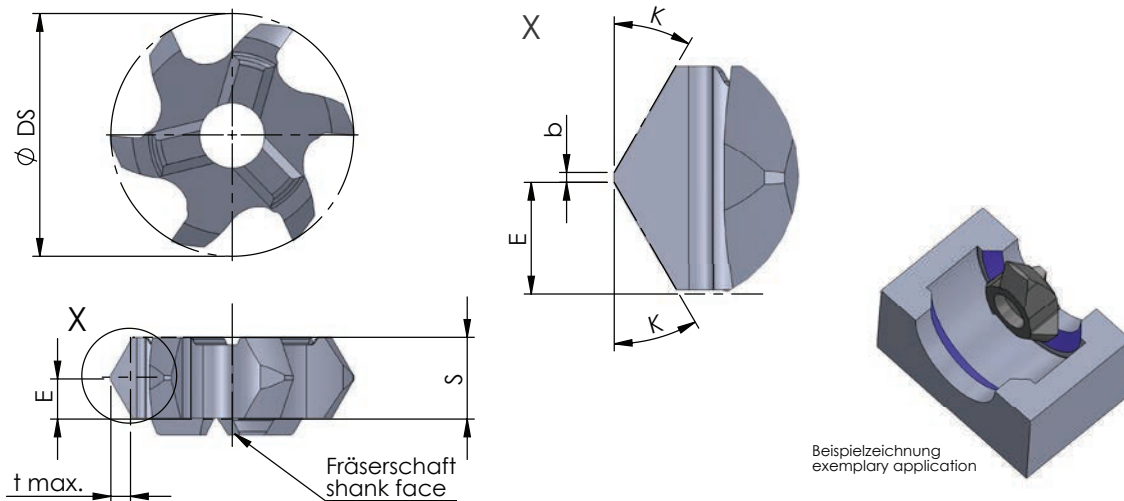

Abmessungen in mm

dimensions in mm

Bestellnummer part number	K	D min.	S	E	Ø DS	b	t max.	Zähnezahl number of teeth	Material			für Fräseschaft for milling shank
									K10F	AL41F	P18C	
Z614.1515.02	15°	14	4.6	2.3	13.7	0.2	0.35	6	●			ZH14...
Z614.2020.02	20°	14	4.6	2.3	13.7	0.2	0.45	6	●			
Z614.3030.02	30°	14	4.6	2.3	13.7	0.2	0.7	6	●			
Z614.4545.02	45°	14	4.6	2.3	13.7	0.2	1.8	6	●			

Weitere HM Sorten können Sie in der Sortenübersicht im Kapitel "Technische Hinweise" und der Preisliste finden.

Bestellbeispiel:
für Sorte AL41F:
Z614.1515.02/AL41F

More carbide grades you can find in the grades summary in the chapter "technical instructions" and in the price list.

order-example:
grade AL41F:
Z614.1515.02/AL41F

MINIMILL

Nut- und Formzirkularfräsen

groove milling by circular interpolation

Typ Z16

Vorwärts- und Rückwärtsfasen

forward & backward chamfering

D min. 16 mm

D min. 16 mm

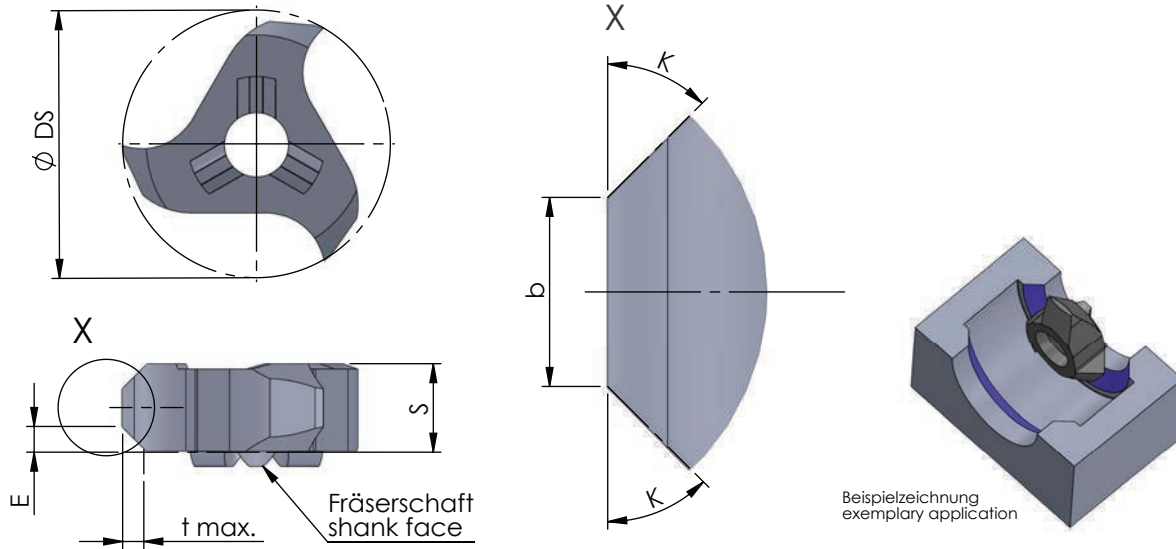

Abmessungen in mm

dimensions in mm

Bestellnummer part number	K	D min.	S	E	$\varnothing DS$	b	t max.	Zähnezahl number of teeth				für Fräseschaft for milling shank
									K10F	AL41F	P18C	
Z16.4545.35	45°	16	4.5	1.6	15.7	1.4	1.4	3	●			
Z16.4545.02	45°	16	4.5	2.2	15.7	0.2	1.8	3	●			ZH14...

Weitere HM Sorten können Sie in der Sortenübersicht im Kapitel "Technische Hinweise" und der Preisliste finden.

Bestellbeispiel:
für Sorte AL41F:
Z16.4545.35/AL41F

More carbide grades you can find in the grades summary in the chapter "technical instructions" and in the price list.

order-example:
grade AL41F:
Z16.4545.35/AL41F

MINIMILL

Nut- und Formzirkularfräsen

groove milling by circular interpolation

Typ Z18

Vorwärts- und Rückwärtsfasen

forward & backward chamfering

D min. 15 mm

D min. 15 mm

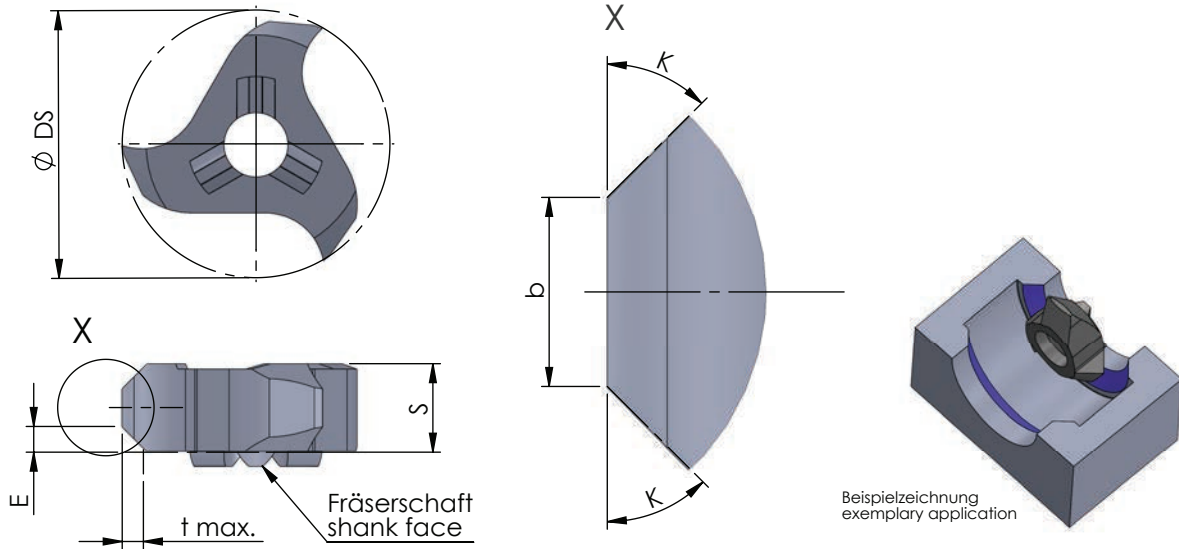

Abmessungen in mm

dimensions in mm

Bestellnummer part number	K	D min.	S	E	$\varnothing DS$	b	t max.	Zähnezahl number of teeth	Material			für Fräseschaft for milling shank
									K10F	AL41F	P18C	
Z18.4545.DS15	45°	15	5.85	2.9	14.7	0.2	2.5	3	●			
Z18.4545.58	45°	18	5.85	1.75	17.7	2.5	1.4	3	●			ZH18...

Weitere HM Sorten können Sie in der Sortenübersicht im Kapitel "Technische Hinweise" und der Preisliste finden.

Bestellbeispiel:
für Sorte AL41F:
Z18.4545.58/AL41F

More carbide grades you can find in the grades summary in the chapter "technical instructions" and in the price list.

order-example:
grade AL41F:
Z18.4545.58/AL41F

MINIMILL

Nut- und Formzirkularfräsen

groove milling by circular interpolation

Typ Z18

Vorwärts- und Rückwärtsfasen mit Radius

forward & backward chamfering with radius

D min. 18 mm

D min. 18 mm

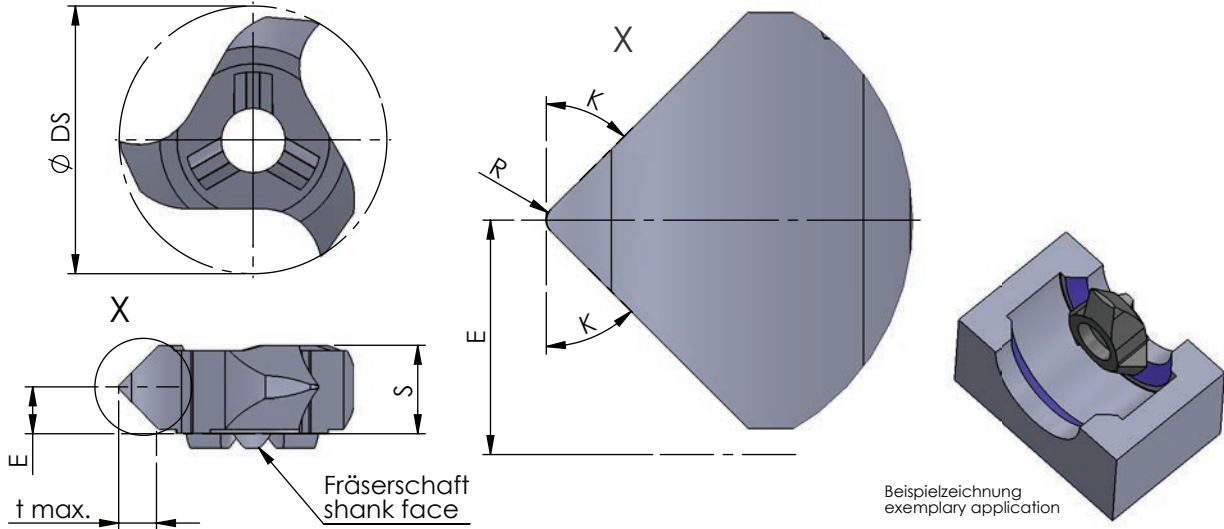

Abmessungen in mm

dimensions in mm

Bestellnummer part number	K	D min.	S	E	R	$\varnothing DS$	t max.	Zähnezahl number of teeth	K10F AL41F P18C	für Fräterschaft for milling shank
Z18.4545.02	45°	18	5.85	3.0	0.2	17.7	2.5	3	●	ZH18...

Weitere HM Sorten können Sie in der Sortenübersicht im Kapitel "Technische Hinweise" und der Preisliste finden.

Bestellbeispiel:
für Sorte AL41F:
Z18.4545.02/AL41F

More carbide grades you can find in the grades summary in the chapter "technical instructions" and in the price list.

order-example:
grade AL41F:
Z18.4545.02/AL41F

MINIMILL

Nut- und Formzirkularfräsen

groove milling by circular interpolation

Typ Z22

Vorwärts- und Rückwärtsfasen

forward & backward chamfering

D min. 22 mm

D min. 22 mm

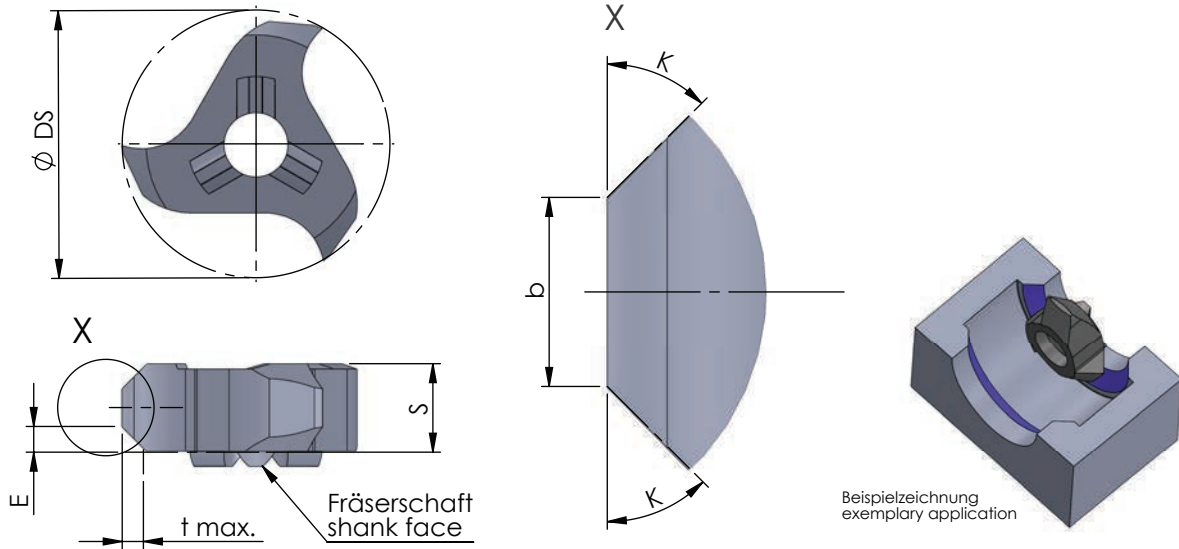

Abmessungen in mm

dimensions in mm

Bestellnummer part number	K	D min.	S	E	$\varnothing DS$	b	t max.	Zähnezahl number of teeth	K10F AL41F P18C	für Fräterschaft for milling shank
Z22.4545.58	45°	22	5.85	2.0	21.7	2.0	1.7	3	●	
Z22.4545.94 *	45°	22	9.4	3.25	21.7	3.0	3.0	3	●	ZH22...

Weitere HM Sorten können Sie in der Sortenübersicht im Kapitel "Technische Hinweise" und der Preisliste finden.

*Achtung: für diesen Schneideinsatz Sonderschraube M5/16-MM

Best.beisp.: für Sorte AL41F: Z22.4545.58/AL41F

More carbide grades you can find in the grades summary in the chapter "technical instructions" and in the price list.

*attention: this insert needs special screw M5/16-MM

order-example: grade AL41F: Z22.4545.58/AL41F

MINIMILL

Nut- und Formzirkularfräsen

groove milling by circular interpolation

Typ Z618 / Z622 / Z628

Vorwärts- und Rückwärtsfasen

forward & backward chamfering

D min. 15 - 28 mm

D min. 15 - 28 mm

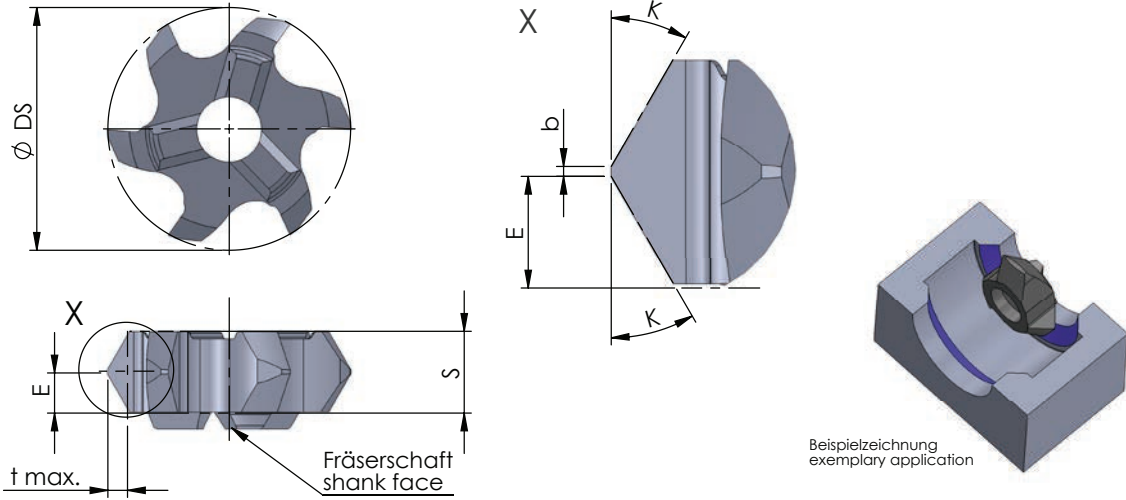

Abmessungen in mm

dimensions in mm

Bestellnummer part number	K	D min.	S	E	Ø DS	b	t max.	Zähnezahl number of teeth				für Fräseschaft for milling shank
									K10F	AL41F	P18C	
Z618.4545.DS15	45°	15	5.75	2.75	14.7	0.5	1.6	6		●		ZH18...
Z618.4545.58	45°	18	5.75	2.9	17.7	0.2	2.2	6		●		ZH18...
Z622.4545.63	45°	22	6.05	3.7	21.7	0.2	2.0	6		●		ZH22...
Z628.4545.02	45°	28	6.50	3.7	27.7	0.2	2.0	6		●		ZH28...

Weitere HM Sorten können Sie in der Sortenübersicht im Kapitel "Technische Hinweise" und der Preisliste finden.

Bestellbeispiel:
für Sorte AL41F:
Z618.4545.58/AL41F

More carbide grades you can find in the grades summary in the chapter "technical instructions" and in the price list.

order-example:
grade AL41F:
Z618.4545.58/AL41F

MINIMILL

Nut- und Formzirkularfräsen

groove milling by circular interpolation

Typ Z620 / Z628

Stirn- und Planfräsen

face milling

D min. 20 / 28 mm

D min. 20 / 28 mm

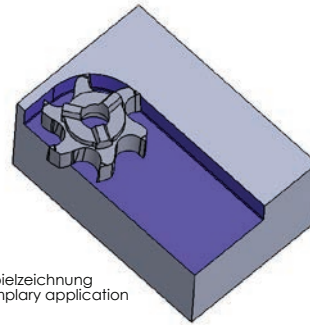
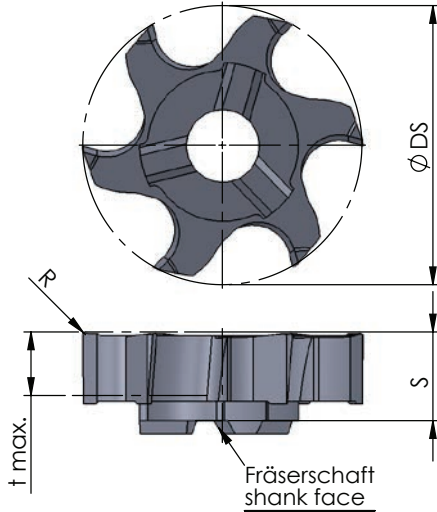

Abmessungen in mm

dimensions in mm

Bestellnummer part number	D min.	S	R	Ø DS	t max.	Zähnezahl number of teeth				für Frälerschaft for milling shank
							K10F	AL41F	P18C	
Z620.SP50.02	20	6.2	0.2	19.7	5.0	6	●			ZH22...
Z628.SP50.02	28	6.2	0.2	27.7	5.0	6	●			ZH28...

Weitere HM Sorten können Sie in der Sortenübersicht im Kapitel "Technische Hinweise" und der Preisliste finden.

Bestellbeispiel:
für Sorte AL41F:
Z620.SP50.02/AL41F

More carbide grades you can find in the grades summary in the chapter "technical instructions" and in the price list.

order-example:
grade AL41F:
Z620.SP50.02/AL41F

MINIMILL

Nut- und Formzirkularfräsen

groove milling by circular interpolation

Sets

D min. 12 mm

D min. 18 mm

Bestellnummer
part number

Inhalt
Content

K10F
AL41F
P18C

SET-MINI-MILLZ12



- Sicherungsringe DIN471/472 und Nutfräsen allgemein
- Nutfräsen Vollradius
- Vorwärts- und Rückwärtsfasen

- for circlips DIN471/472, groove milling general use
- groove milling full radius
- forward & backward chamfering

Fräseschaft / milling shank:

1 x ZH10.1606.12.B.ST

Schneideinsatz / insert:

1 x Z12.0150.02

1 x Z12.0200.00

1 x Z12.0011.22

1 x Z12.4545.35



Bestellnummer
part number

Inhalt
Content

K10F
AL41F
P18C

SET-MINI-MILLZ18



- Sicherungsringe DIN471/472 und Nutfräsen allgemein
- Nutfräsen Vollradius
- Vorwärts- und Rückwärtsfasen

- for circlips DIN471/472, groove milling general use
- groove milling full radius
- forward & backward chamfering

Fräseschaft / milling shank:

1 x ZH18.1609.18.B.ST

Schneideinsatz / insert:

1 x Z18.0150.00

1 x Z18.0300.02

1 x Z18.0011.22

1 x Z18.4545.58



MINIMILL

Nut- und Formzirkularfräsen

groove milling by circular interpolation

Sets

D min. 22 mm

D min. 37 mm



	Bestellnummer part number	Inhalt Content	K10F AL41F P18C
	<p>SET-MINI-MILLZ22</p> <ul style="list-style-type: none"> • Nutfräsen allgemein • Nutfräsen Vollradius • Vorwärts- und Rückwärtsfasen <ul style="list-style-type: none"> • groove milling general use • groove milling full radius • forward & backward chamfering 	<p>Frälerschaft / milling shank: 1 x ZH22.1612.24.B.ST</p> <p>Schneideinsatz / insert: 1 x Z622.0150.01 1 x Z622.0400.02 1 x Z22.0014.28 1 x Z22.4545.58</p>	<p>● ● ● ●</p>
	<p>SET-MINI-MILLZ637</p> <ul style="list-style-type: none"> • Nutfräsen allgemein • Spannschraube Klemmhalter <ul style="list-style-type: none"> • groove milling general use • screw milling shank 	<p>Frälerschaft / milling shank: 1 x ZH22.1612.24.B.ST</p> <p>Schneideinsatz / insert: 2 x Z637.0150.01</p> <p>Spannschraube / screw: 1x M5-MM</p>	<p>●</p>
<p>Bestellbeispiel: SET-MINI-MILLZ22</p>		<p>order-example: SET-MINI-MILLZ22</p>	

MINIMILL

Nut- und Formzirkularfräsen

groove milling by circular interpolation

Impressionen

impressions

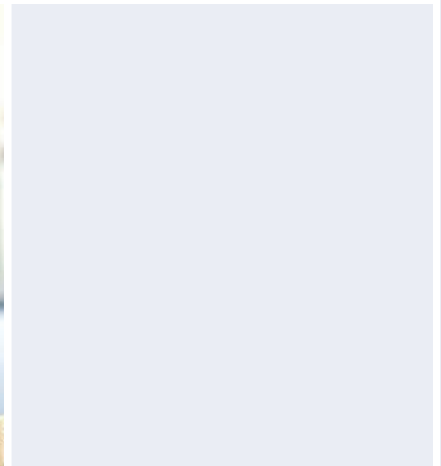
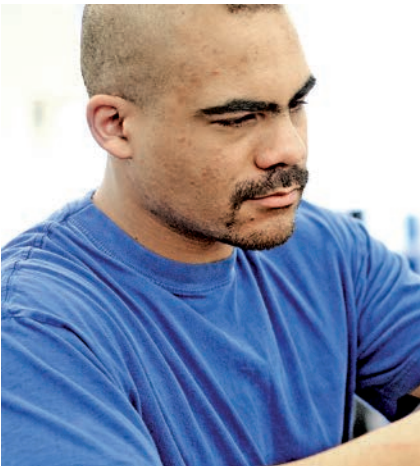
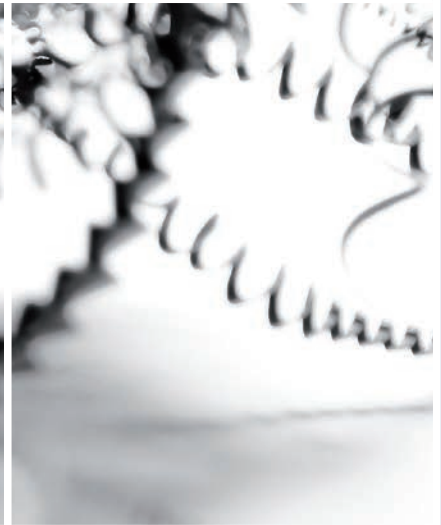
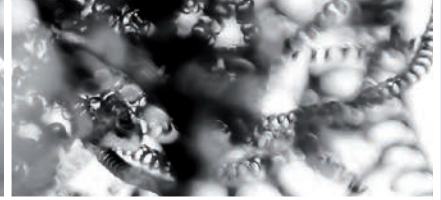
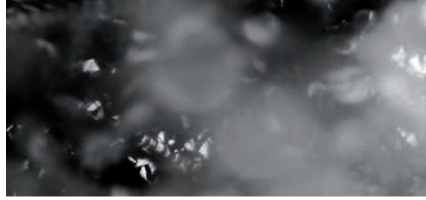

MINIMILL

Nut- und Formzirkularfräsen

groove milling by circular interpolation

Technische Hinweise

Grundsätzliche Informationen zum Gewindefräsen

Technical instructions,
basic informations about thread milling

Vor- und Nachschnitt

Beim Zirkularfräsen von Gewinden entsteht durch die Steigung ein Vor- und Nachschnitt. Um hier die Verletzung des Gewindepfils so gering wie möglich zu halten muß ein Werkzeug mit einem möglichst kleinen Schneidkreis gewählt werden.

Die nachfolgende Skizze zeigt die Verhältnisse bei der Bearbeitung:

(Grün: Konturverletzung X gering = gut; Rot: Konturverletzung X erheblich = schlecht)

Thread profile violation

Thread milling by interpolation causes a profile violation. To keep the violation minimal you should use the cutting circle as small as possible.

The following sketch shows the relations during the process:

(green: profile violation X low = good; red: profile violation X big = bad)

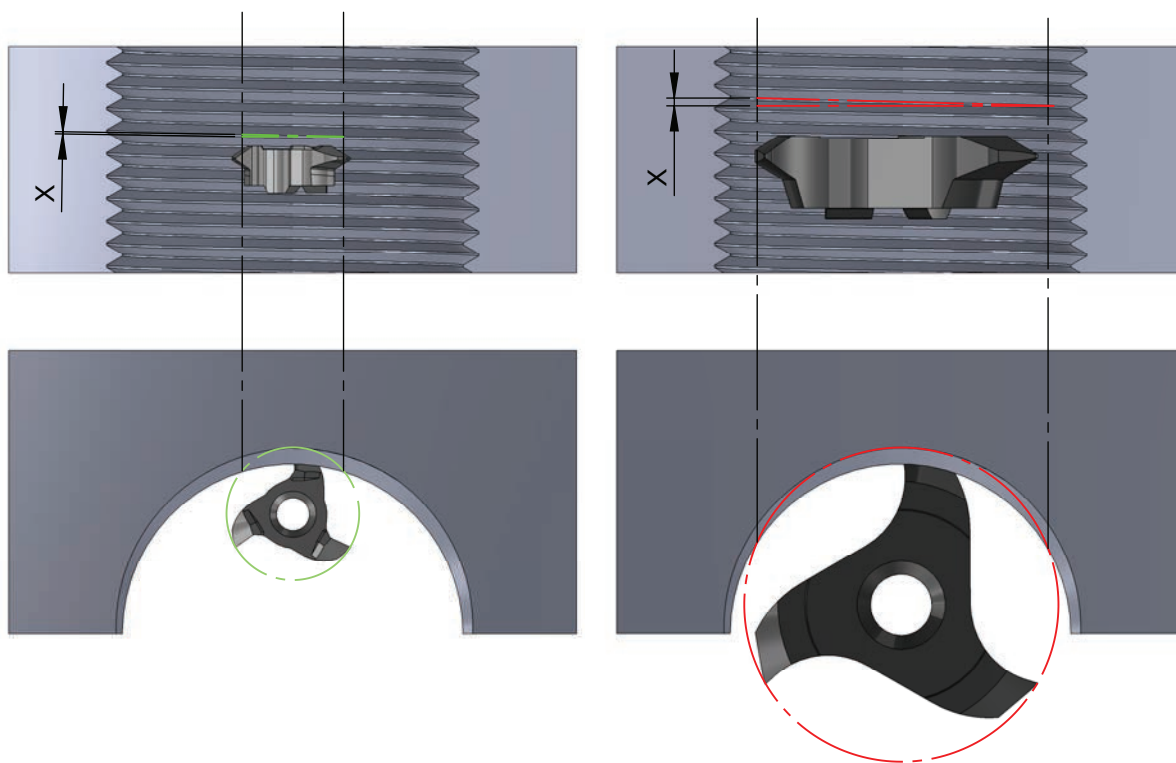

MINIMILL

Nut- und Formzirkularfräsen

groove milling by circular interpolation

Technische Hinweise

Grundsätzliche Informationen zum Gewindefräsen

Technical instructions,
basic informations about thread milling

Teilprofil

Werkzeuge mit Teilprofil sind Mehrbereichswerkzeuge, d.h. mit diesem Werkzeug können Gewinde mit unterschiedlichen Steigungen hergestellt werden. Dies ist aber nur mit einer kleinen Abweichung vom Normprofil möglich. Abgestimmt ist das Werkzeug auf die kleinste angegebene Steigung, dieses Profil kann ohne Abweichung produziert werden. Alle weiteren Steigungen können ebenfalls produziert werden, hier weicht aber das gefertigte Profil gegenüber der Norm durch eine höhere Gewindetiefe ab. In der Regel ist dies unproblematisch, muß aber gegebenenfalls im Einzelfall genauer betrachtet werden.

Partial profile

Tools with partial profile are multi-purpose tools, that means you can process several pitches with one tool. The processed shape has a small difference to the standard profile. Created is that tool for the smallest pitch, this profile depends to the standard.

All other pitches are producible, but only with a small deviation. Normally this causes no problem, but sometimes you have to decide case by case.

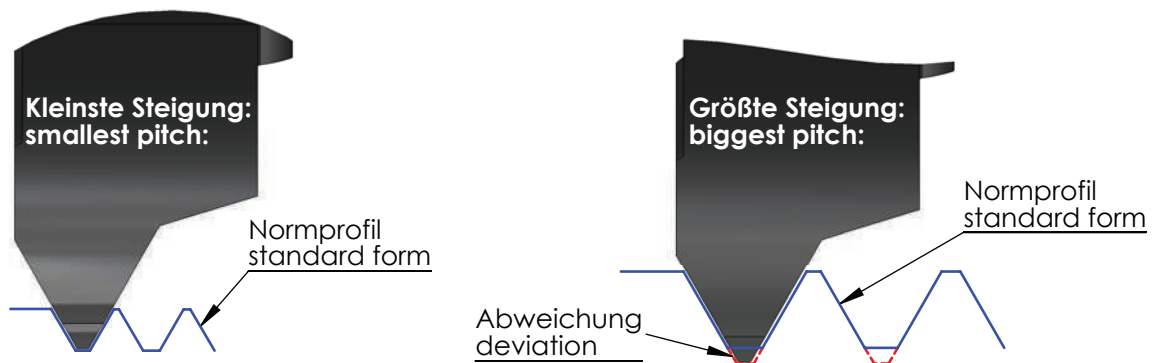

MINIMILL

Nut- und Formzirkularfräsen

groove milling by circular interpolation

Technische Hinweise

Grundsätzliche Informationen zum Gewindefräsen

Technical instructions, basic informations about thread milling

Auswahlhilfe Mehrbereichswerkzeuge

In der nachfolgenden Tabelle sind alle DÜMMEL - Mehrbereichswerkzeuge aufgeführt. Anhand dieser Tabelle können Sie den jeweiligen Einsatzbereich entnehmen (blau= optimale Kontur, grau= mögliche Konturen):

Selection guide multi-purpose-tools

In the following chart are all DÜMMEL - multi-purpose-tools listed. This chart shows the possible area of application (blue= optimal profile; grey= possible profiles):



ab Gewindegröße / starting with thread-size	Steigung (mm)/ pitch (mm)															
	1	1,25	1,5	1,75	2	2,5	2,75	3	3,5	3,75	4	4,5	5	5,5	6	
Z610.0510.01	M12	M13	M14	M14												
Z610.0720.01	M13	M13	M14	M14	M15											
Z610.0815.01			M15	M15	M16	M18	M18									
Z610.2530.01					M16	M18	M18	M19								
Z12.0510.01	M14	M15	M15	M16												
Z12.0720.01	M14	M15	M15	M16	M16											
Z12.0815.01			M15	M16	M16	M17	M17									
Z12.2530.01					M16	M17	M17	M18								
Z614.0510.01	M15	M15	M16	M16												
Z614.0720.01	M15	M15	M16	M17	M17											
Z614.0815.01			M17	M17	M18	M20	M21									
Z614.2530.01					M18	M20	M21	M21								
Z16.0510.01	M18	M19	M20	M20												
Z16.0720.01	M18	M19	M20	M20	M21											
Z16.0815.01			M20	M20	M21	M21	M22									
Z16.2530.01					M21	M21	M22	M22								
Z18.0510.01	M21	M21	M22	M22												
Z18.0720.01/Z618.0720.01	M21	M21	M22	M22	M23											
Z18.0815.01			M22	M22	M23	M24	M24									
Z18.1325.01					M23	M24	M24	M24								
Z18.2535.01/Z618.2545.01					M23	M24	M24	M24	M25							
Z18.1020.01					M23	M24	M24	M24	M25	M26						
Z18.1630.01						M24	M24	M24	M25	M26	M26	M27	M28			
Z18.1835.01								M24	M25	M26	M26	M27	M28	M28		
Z22.0720.01/Z622.0720.01	M25	M25	M25	M26	M27											
Z22.0815.01			M26	M26	M27	M28	M28									
Z22.1020.01					M27	M28	M28	M29	M30	M30						
Z22.2545.01/Z622.2545.01					M27	M28	M28	M29	M30	M30	M30	M31				
Z22.1630.01						M28	M28	M29	M30	M30	M30	M31	M32			
Z22.2140.01									M30	M30	M30	M31	M32	M33	M34	
Z22.2445.01									M30	M30	M30	M31	M32	M33	M34	
Z28.0720.01	M31	M31	M32	M32	M33											
Z28.1525.01/Z628.1525.01			M32	M32	M33	M34										
Z28.3050.01/Z628.3050.01						M34	M35	M35	M36	M36	M37	M38	M39			
Z28.5060.01											M37	M38	M39	M39	M40	

MINIMILL

Nut- und Formzirkularfräsen

groove milling by circular interpolation

Technische Hinweise

Hartmetallsorten und Beschichtungen

Technical instructions, carbide grades and coatings

K10F

Universell einsetzbares Feinkornhartmetall mit guter Verschleißfestigkeit. Unbeschichtet geeignet für Anwendungen mit niedrigen und mittleren Schnittgeschwindigkeiten, sowie die Bearbeitung von Nicht-eisenmetallen.

All purpose micrograin carbide with good abrasion resistance. Uncoated for applications with low or medium cutting speeds and machining of non-ferrous materials.

CBN

Zähe CBN-Sorte für Anwendungen mit niedrigen Schnittgeschwindigkeiten. Geeignet für gehärtete Stähle, unterbrochene Schnitte und Grauguss.

Ductile CBN grade for applications with lower cutting speed. Suitable for hardened steel, interrupted cuts and cast iron.

CN45F

Universell einsetzbare PVD-TiN-Beschichtung. Diese Allround-Sorte ist für niedrige und mittlere Schnittgeschwindigkeiten mit Einschränkung bei NE-Metallen

PVD-TiN coating - all purpose, all around grade is suitable for low and medium cutting speed with restrictions on non-ferrous materials.

AL41F

Sehr universell einsetzbare TiAlN-Beschichtung mit hoher Temperaturbeständigkeit bei hoher Härte. Sehr gut geeignet auch für NE-Metalle.

TiAlN coating - very universal with a high resistance to high temperature and hardness. Very suitable also for non-ferrous metals.

PD2F

Beschichtung für den universellen Einsatz bei niedrigen und mittleren Schnittgeschwindigkeiten.

Coating for universal use with medium and low speed.

XC2A

Beschichtung mit einer excellenten Warmhärte, Oxidationsbeständigkeit und thermischen Isolationsfähigkeit. Ideal für Hartzerspannung >60HRC

Coating with excellent hot hardness, high oxidation resistance and thermal insulation capacity. Perfect for hard machining >60 HRC.

MINIMILL

Nut- und Formzirkularfräsen

groove milling by circular interpolation

Technische Hinweise

Hartmetallsorten und Beschichtungen

Technical instructions, carbide grades and coatings

P01C

Beschichtung für die Bearbeitung in zähen Materialien bei niedrigen und mittleren Schnittgeschwindigkeiten.

Coating for the processing in tough material with medium or low cutting speed

P03C

Beschichtung für die Bearbeitung von schwer zerspanbaren Materialien. Sehr gut auch für die Trockenbearbeitung geeignet.

Coating for materials which are difficult to machine. Perfect to use for dry machining.

P07C

Beschichtung für die Bearbeitung von Titan, Edelstahl und Molybdän.

Coating to machine titanium, stainless steel and molybdenum.

P18C

Universell einsetzbare Hochleistungsschicht mit hoher Oxidationsbeständigkeit, Verschleißfestigkeit und Warmhärte.

Very universal high performance coating with high oxidation resistance, wear resistance and hot hardness resistance.

NEME

Beschichtung für die Bearbeitung von Aluminium, Al-Legierungen, NE-Metallen und Composite-Werkstoffen.

Coating for machining aluminium, alloys, non-ferrous metals and composite materials.



MINIMILL

Nut- und Formzirkularfräsen

groove milling by circular interpolation

Technische Hinweise

Ermittlung der Schnittdaten für das Nut- und Formzirkularfräsen

Technical instructions, evaluation of the cutting data for groove milling

$$n = \frac{V_c \cdot 1000}{d \cdot \pi} \quad V_{\text{eff}} = f_z \cdot z \cdot n \quad f_z = h_m \sqrt{\frac{d}{a_e}}$$

Fräsen Außenkontur
milling external

$$V_{\text{prog}} = \frac{V_{\text{eff}} \cdot (D + d)}{D}$$

$$V_{\text{eff}} = \frac{D \cdot V_{\text{prog}}}{(D + d)}$$

Fräsen Innenkontur
milling internal

$$V_{\text{prog}} = \frac{V_{\text{eff}} \cdot (D - d)}{D}$$

$$V_{\text{eff}} = \frac{D \cdot V_{\text{prog}}}{(D - d)}$$

Formel-Zeichen
formula characters

Bezeichnungen
specifications

Einheit
unit

d

Fräserdurchmesser
milling diameter

mm

D

Gewindedurchmesser
thread diameter

mm

V_{eff}

effektive Vorschubgeschwindigkeit
(auf / an der Kontur)
feed rate of tool tip

mm / min

V_{eint}

programmierter Eintauchvorschub
programmed plunge feed

mm / min

V_{prog}

programmierte Vorschubgeschwindigkeit
feed rate of tool center

mm / min

z

Schneidenzahl Fräser
number of cutting edges

Stk.
pcs.

Nach Möglichkeit immer im Kreisbogen eintauchen.

Always plunge in a circular arc where possible.

Beim geraden Eintauchen nur 1/3 des Vorschubs verwenden und erst beim Erreichen der Frästiefe vollen Vorschub fahren.

When plunging straight use only 1/3 of the feed and do not traverse full feed until reaching the milling depth.

MINIMILL

Nut- und Formzirkularfräsen

groove milling by circular interpolation

Technische Hinweise

Ermittlung der Schnittdaten für das Nut- und Formzirkularfräsen

Technical instructions, evaluation of the cutting data for groove milling

$$n = \frac{V_c \cdot 1000}{d \cdot \pi}$$

$$V_f = n \cdot z \cdot f_z \text{ mm/min}$$

$$f_z = h_m \sqrt{\frac{2r}{a_e}}$$

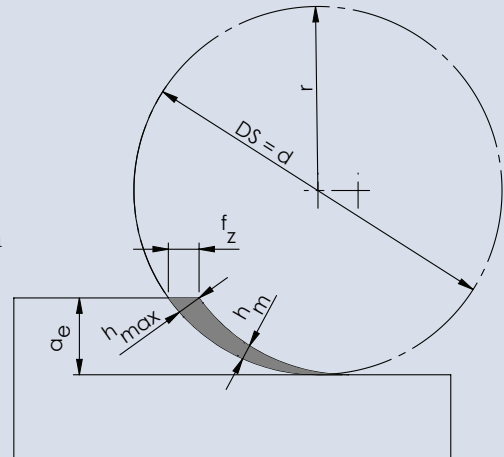

Formel-Zeichen
formula characters

Bezeichnungen
specifications

Einheit
unit

a_e

Spantiefe radial
radial depth of cut

mm

f_z

Vorschub pro Zahn
feed / tooth

mm

h_m

mittlere Spandicke
medium thickness of chip

mm

h_{max}

maximale Spandicke
maximum thickness of chip

mm

n

Spindeldrehzahl
revolutions

U / min

r

Radius Fräser
radius of cutter

mm

V_c

Schnittgeschwindigkeit
cutting speeds

m / min

V_f

Vorschubgeschwindigkeit
feed rate of tool center

mm / min

z

Schneidenzahl Fräser
number of cutting edges

Stk.
pcs.



MINIMILL

Nut- und Formzirkularfräsen

groove milling by circular interpolation

Technische Hinweise

Schnittdaten

Technical instructions, cutting data



	Werkstoff	Festigkeit	Werkstoff-Nr	Werkstoffbezeichnung	Werkstoff-Nr	
P	Allgemeiner Baustahl	< 800 N/mm2	1.0037	St37-2	1.0570	
	Automatenstahl	< 800 N/mm2	1.0718	9SMnPb28	1.0727	
	Einsatzstahl unlegiert	< 800 N/mm2	1.0401	C15	1.0481	
	Einsatzstahl legiert	< 1000 N/mm2	1.7331	16MnCr5 (EC80)	1.7015	
	Vergütungsstahl unlegiert	< 850 N/mm2	1.0503	C45	1.1191	
	Vergütungsstahl unlegiert	< 1000 N/mm2	1.0601	C60	1.1221	
	Vergütungsstahl legiert	< 800 N/mm2	1.5131	50MnSi4	1.7030	
	Vergütungsstahl legiert	< 1300 N/mm2	1.5755	31NiCr14	1.7033	
	Stahlguss	< 850 N/mm2	0.9650	G-X260Cr27	1.6750	
	Nitrierstahl	< 1000 N/mm2	1.8504	34CrAl6	1.8507	
	Nitrierstahl	< 1200 N/mm2	1.8515	31CrMo12	1.8523	
	Wälzlagerstahl	< 1200 N/mm2	1.3505	100Cr6 (W3)	1.3543	
	Federstahl	< 1200 N/mm2	1.5026	55Si7	1.7176	
	Schnellarbeitsstahl	< 1300 N/mm2	1.3344	S 6-5-3	1.3255	
	Werkzeugstahl für Kaltarbeit	< 1300 N/mm2	1.2312	40CrMnMoS8 6	1.2379	
	Werkzeugstahl für Warmbeit	< 1300 N/mm2	1.2343	X38CrMoV 5 1	1.2767	
	M	Stahl und Stahlguss rostfrei geschwefelt	< 850 N/mm2	1.4305	X8CrNiS18 9	1.4105
		Nichtrostender Stahl, ferritisch	< 750 N/mm2	1.4510	X3CrTi17	1.4528
Nichtrostender Stahl, martensitisch		< 900 N/mm2	1.4034	X46Cr13	1.4116	
Nichtrost. Stahl, ferritisch/martensit.		<1100 N/mm2	1.4313	X3CrNi13-4	1.4028	
Nichtrost. Stahl, austenitisch/ferritisch		< 850 N/mm2	1.4460	X8CrNiMo27 5	1.4821	
Nichtrostender Stahl, austenitisch		< 750 N/mm2	1.4301	X5CrNi18-10	1.4571	
K	Hitzebeständig	< 1100 N/mm2	1.4747	X80CrNiSi20	1.4876	
	Grauguss mit Lammellengraphit	100-350N/mm2	0.6010	GG10	0.6025	
	Grauguss mit Lammellengraphit	300-1000N/mm2	0.6030	GG30	0.6045	
	Kugelgraphitguss	300-500N/mm2	0.7040	GGG40	0.7050	
	Kugelgraphitguss	550-800N/mm2	0.7060	GGG60	0.7080	
	Temperguss weis	350-450N/mm2	0.8035	GTW35	0.8045	
	Temperguss weis	500-650N/mm2	0.8055	GTW55	0.8065	
	Temperguss schwarz	350-450N/mm2	0.8135	GTS35	0.8145	
N	Temperguss schwarz	500-700N/mm2	0.8155	GTS55	0.8170	
	Aluminium (unlegiert, niedrig legiert)	< 350 N/mm2	3.0255	Al99,5	3.3308	
	Aluminiumlegierungen < 0,5% Si	< 500 N/mm2	3.0515	AlMn1	3.1355	
	Aluminiumlegierungen 0,5-10% Si	< 400 N/mm2	3.2152	GD-AlSi6Cu4	3.2373	
	Aluminiumlegierungen 10-15% Si	< 400 N/mm2	3.2381	G-AlSi10Mg	3.5562	
	Aluminiumlegierungen > 15% Si	< 400 N/mm2		G-AlSi17Cu4		
	Kupfer (unlegiert, niedrig legiert)	< 350 N/mm2	2.0060	E-Cu57	2.0090	
	Kupfer-Knetlegierungen	< 700 N/mm2	2.0240	CuZn15	2.0265	
	Kupfer-Sonderlegierungen	< 200 HB	2.0916	CuAl5	2.1525	
	Kupfer-Sonderlegierungen	< 300HB	2.0978	CuAl11Ni6Fe5		
	Kupfer-Sonderlegierungen	> 300 HB	2.1247	CuBe2F125		
	Messing kurzspanend, Bronze, Rotguss	< 600 N/mm2	2.0360	CuZn40 (Ms60)	2.0380	
	Messing langspanend	< 600 N/mm2	2.0335	CuZn36 (Ms63)	2.1293	
	Thermoplaste			Delrin, Hostalen		
	Duroplaste			Ferrozell, Bakelit		
	Faserverstärkte Kunststoffe			GFK (Glasfaserverstärkt)		
	Magnesium und Magnesiumlegierungen	< 850 N/mm2	3.5200	M2, MgMn2	3.5612	
	Graphit			C8000, R8500X		
Wolfram und Wolframlegierungen			W-NiFe (Densimet W)			
Molybdän und Molybdänlegierungen			Mo , Mo-50Re			
S	Reinnickel		1.3911	RNi24	1.3927	
	Nickellegierungen		1.3912	Ni36 (Invar)	1.3924	
	Nickellegierungen	< 850 N/mm2	2.4360	S-NiCu 30 Fe		
	Nickel-Chromlegierungen		2.4886	SG-NiMo16Cr16W	2.4610	
	Nickel- und Kobaltlegierungen	< 1300 N/mm2	2.4632	NiCr20Co18Ti	2.4631	
	Nickel- und Kobaltlegierungen	< 1300 N/mm2	2.4634	NiCo20Cr15MoAlTi	2.4654	
	Hochwärmefeste Legierungen	< 1300 N/mm2		Hardox 400	1.4939	
	Nickel-Kobalt-(Chrom-)legierungen	< 1400 N/mm2	2.4806	SG-NiCr20Nb, Inconel 82	2.4851	
	Reintitan	< 900 N/mm2	3.7025	Ti99,8	3.7034	
	Titanlegierungen	< 700 N/mm2	3.7114	TiAl5Sn2	3.7174	
	Titanlegierungen	< 1200 N/mm2	3.7164	TiAl5V4	3.7144	
H	Stahl gehärtet	< 45 HRc				
		46-55HRc				
		56-60 HRc				
		61-65 HRc				
		65-70 HRc				

MINIMILL

Nut- und Formzirkularfräsen

groove milling by circular interpolation

Technische Hinweise

Schnittdaten

Technical instructions, cutting data



Werkstoffbezeichnung	Werkstoff- Nr	Werkstoffbezeichnung	Vc (m/min.)	fz (mm)	h max. (mm)	mit/with AL41F
St52-3	1.0060	St60-2	80-200	0,03 - 0,10	0,03-0,05	Haupt-Anwendung
45S20	1.0757	46SPb2		0,03 - 0,10	0,03-0,05	
17Mn4	1.1141	C15E (CK15)		0,03 - 0,10	0,03-0,05	
13Cr3 (EC60)	1.5919	15CrNi6	60-180	0,03 - 0,08	0,03-0,05	
Ck45	1.0535	C55		0,03 - 0,08	0,03-0,05	
Ck60	1.0540	C50		0,03 - 0,08	0,03-0,05	
28Cr4	1.7225	42CrMo4	60-160	0,03 - 0,10	0,03-0,05	
34Cr4	1.3565	48CrMo4		0,02 - 0,07	0,03-0,05	
GS-20NiCrMo3 7	1.6582	GS-34 CrNiMo 6		0,03 - 0,10	0,03-0,05	
34AlMo5	1.8509	41CrAlMo7	30-100	0,03 - 0,10	0,03-0,05	
39CrMoV19 3	1.8550	34 CrAlNi 7		0,02 - 0,08	0,03-0,05	
X192CrMo17	1.3520	100 CrMn 6 (W4)		0,02 - 0,07	0,03-0,05	
55Cr3	1.7701	51CrMoV4	80-120	0,02 - 0,07	0,03-0,05	
S 18-1-2-5	1.3294	PMH56-5-3-8; ASP30		0,02 - 0,07	0,03-0,05	
X155CrVMo12 1	1.2316	X38CrMo16; RAMAX		0,02 - 0,07	0,03-0,05	
X45NiCrMo4	1.2842	90MnCrV8	100-170	0,02 - 0,07	0,03-0,05	
X4CrMoS18	1.4107	GX8CrNi12		0,03 - 0,08	0,03-0,05	
X105CrCoMo18 2	1.4016	X6Cr17		0,03 - 0,10	0,03-0,05	
X50CrMoV15	1.4106	X2CrMoSiS18-2-1	250-800	0,02 - 0,07	0,03-0,05	
X30Cr13	1.4104	X14CrMoS17		0,02 - 0,07	0,03-0,05	
X20CrNiSi25 4	1.4462	X2CrNiMoN22-5-3 (Duplex)		0,02 - 0,07	0,03-0,05	
X6CrNiMoTi17 12 2	1.4449	X3CrNiMo18-12-3	200-500	0,02 - 0,07	0,03-0,05	
X10NiCrAlTi32-21	1.4825	GX25CrNiSi18-9		0,02 - 0,07	0,03-0,05	
GG25				0,03 - 0,10	0,03-0,05	
GG45			150-180	0,03 - 0,10	0,03-0,05	
GGG50				0,03 - 0,10	0,03-0,05	
GGG80				0,03 - 0,10	0,03-0,05	
GTW45			10-100	0,03 - 0,10	0,03-0,05	
GTW65				0,03 - 0,10	0,03-0,05	
GTS45				0,03 - 0,10	0,03-0,05	
GTS70			20-100	0,03 - 0,10	0,03-0,05	
Al99,9Mg0,5	3.0256	E-Al H		0,04 - 0,15	0,03-0,05	
AlCuMg2	3.3315	AlMg1		0,04 - 0,15	0,03-0,05	
GD-AlSi9Mg	3.2134	GD-AlSi5Cu1Mg	10-60	0,04 - 0,15	0,03-0,05	
G-MgAl6	3.2525	S-AlSi12		0,04 - 0,15	0,03-0,05	
G-AlSi25CuNiMg		G-AlSi21CuNiMg		0,04 - 0,15	0,03-0,05	
SF-Cu	2.1522	CuSi2Mn	-	0,04 - 0,15	0,03-0,05	
CuZn30	2.0321	CuZn37		0,04 - 0,15	0,03-0,05	
CuSi3Mn		Ampco 8-16		0,04 - 0,15	0,03-0,05	
		Ampco18-26	-	0,04 - 0,15	0,03-0,05	
		Ampco M-4		0,04 - 0,15	0,03-0,05	
CuZn39Pb2 (Ms58)	2.0410	CuZn44Pb2		0,04 - 0,15	0,03-0,05	
CuCrZr	2.1080	CuSn6Zn6	-	0,04 - 0,15	0,03-0,05	
Makrolon, Novodur		Acrylglas, Polystyrol		0,04 - 0,15	0,03-0,05	
Pertinax		Resopal		0,04 - 0,15	0,03-0,05	
CFK (Kohlefaserverstärkt)		AFK (Amidfaserverstärkt)	-	0,04 - 0,15	0,03-0,05	
MgAl6Zn1	3.5812	MgAl8Zn1		0,02 - 0,10	0,03-0,05	
R8650		Technograph15		0,04 - 0,15	0,03-0,05	
W-Cu80/20		W93NiFe (DENAL)	-	0,02 - 0,10	0,03-0,05	
TZC, TZM		MHC , ODS		0,02 - 0,10	0,03-0,05	
RNi8	1.3926	RNi12	-	0,005 - 0,05	0,03-0,05	
Ni54	1.3921	Ni49		0,005 - 0,05	0,03-0,05	
NiCu 30 Fe		Monel 400		0,005 - 0,05	0,03-0,05	
NiMo16Cr16Ti		Hastelloy C-276	-	0,005 - 0,05	0,03-0,05	
NiCr20TiAl		Nimonic 80		0,005 - 0,05	0,03-0,05	
NiCr19Co14Mo4Ti		Waspaloy		0,005 - 0,05	0,03-0,05	
X12CrNiMo12	1.4980	X6NiCrTiMoVB25-15-2	-	0,005 - 0,05	0,03-0,05	
NiCr23Fe, Inconel 601	2.4667	SG-NiCr19NbMoTi		0,005 - 0,05	0,03-0,05	
Ti99,7	3.7064	Ti99,5		0,005 - 0,05	0,03-0,05	
TiAl6V6Sn2	3.7124	TiCu2	-	0,005 - 0,05	0,03-0,05	
TiAl6Sn2Zr4Mo2	3.7154	TiAl6Zr5		0,005 - 0,05	0,03-0,05	
				0,002 - 0,05		
			-	0,002 - 0,05		
				0,002 - 0,05		

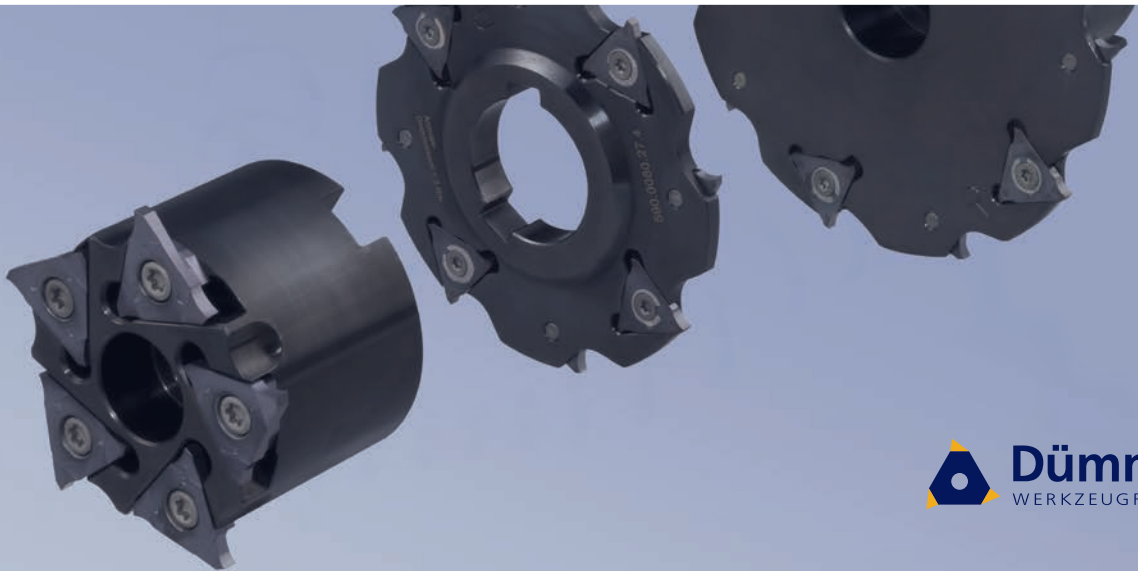

SYSTEM 500



**Nut- und Formfräsen
Nut- und Trennfräsen**

**Groove milling by circular interpolation
Groove milling and slotting cutter**

SYSTEM 500

Nut- und Trennfräsen

groove milling
and slotting cutter

Übersicht

summary

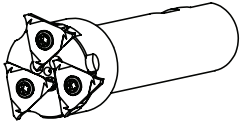

Allgemeine Beschreibung

general instructions

... 434

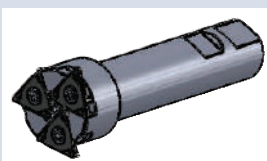

Messerköpfe

milling cutter type

Maße dimensions

Seite page

500.44.3

Fräuserschaft

milling shank

D min. 45
t max. 4.0

... 435

510.0063.05-D

Messerkopf

milling cutter

D min. 64
t max. 5.0

... 436

510.0080.08-D

Messerkopf

milling cutter

D min. 81
t max. 5.0

... 437

581...

Messerkopf

milling cutter

D min. 64
t max. 5.0

... 438



Fräswendeschneidplatten

indexable milling inserts

Maße dimensions

Seite page

Typ 514

für Sicherungsringe DIN 471/472
für Typ 500 / Typ 510 / Typ 581

for circlips DIN 471/472
for type 500 / Typ 510 / Typ 581

... 439

Typ 514

für Sicherungsringe DIN 471/472,
mit Nutaußenkantenfasung
für Typ 500 / Typ 510 / Typ 581

for circlips DIN 471/472,
with chamfer
for type 500 / type 510 / type 581

... 440

Typ 514

metrisches ISO-Gewinde,
Teilprofil, innen
für Typ 500 / Typ 510 / Typ 581

metric ISO-thread,
partial profile, internal
for type 500 / type 510 / type 581

Steigung / pitch
P = 1.5 - 6.0

... 441

Typ 514

metrisches ISO-Gewinde,
Vollprofil, innen
für Typ 500 / Typ 510 / Typ 581

metric ISO-thread,
full profile, internal
for type 500 / type 510 / type 581

Steigung / pitch
P = 1.5 - 5.5

... 442

SYSTEM 500

Nut- und Trennfräsen

groove milling
and slotting cutter

Übersicht

summary

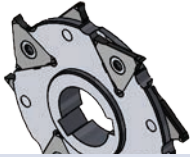

**Hochleistungsscheibenfräser
mit Wendeschneidplatten**
Breite 6 / 8 / 10 mm

**high performance
disk-milling cutter
with indexable inserts**
width 6 / 8 / 10 mm

**Maße
dimensions**

**Seite
page**

**Typ 590... .6
Typ 590... .8
Typ 590... .10**

Hochleistungsscheibenfräser

high performance
disk-milling cutter

b = 6 / 8 / 10 mm ... **443**

Typ 591... .6

Hochleistung Aufsteck-Scheibenfräser

high performance arbour mounted
disk-milling cutter

b = 6 mm ... **444**



Fräswendeschneidplatten

indexable milling inserts

**Maße
dimensions**

**Seite
page**

Typ R/L 514

Fräswendeschneidplatten:
für Hochleistungsscheibenfräser
Typ 590... .6 / Typ 591... .6
Typ 590... .8 / Typ 591... .8
Typ 590... .10 / Typ 591... .10

indexable milling inserts:
for high performance
disk-milling cutter
Typ 590... .6 / Typ 591... .6
Typ 590... .8 / Typ 591... .8
Typ 590... .10 / Typ 591... .10

b = 6 / 8 / 10 mm ... **445**



SYSTEM 500

Nut- und Trennfräsen

groove milling
and slotting cutter

Übersicht

summary

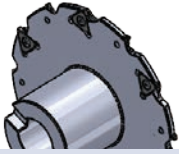

**Hochleistungstrennfräser
mit Wendeschneidplatten
Breite 3 / 4 / 5 mm**

**high performance
slotting cutter
with indexable inserts
width 3 / 4 / 5 mm**

**Maße
dimensions**

**Seite
page**

Typ 590... .3
Typ 590... .4
Typ 590... .5

Hochleistungstrennfräser

high performance
slotting cutter

b = 3 / 4 / 5 mm ... **446**

Typ 591... .3

Hochleistungs Aufsteck-Trennfräser

high performance arbour mounted
slotting cutter

b = 3 mm ... **447**

Typ 591... .4

Hochleistungs Aufsteck-Trennfräser

high performance arbour mounted
slotting cutter

b = 4 mm ... **448**

Typ 591... .5

Hochleistungs Aufsteck-Trennfräser

high performance arbour mounted
slotting cutter

b = 5 mm ... **449**

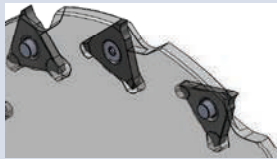

Fräswendeschneidplatten

indexable milling inserts

**Maße
dimensions**

**Seite
page**

Typ R/L 510

Fräswendeschneidplatten:
für Hochleistungs (Aufsteck)-
Trennfräser
Typ 590... .3 / Typ 591... .3
Typ 590... .4 / Typ 591... .4
Typ 590... .5 / Typ 591... .5

indexable milling inserts:
for high performance
(arbour mounted) slotting cutter
Typ 590... .3 / Typ 591... .3
Typ 590... .4 / Typ 591... .4
Typ 590... .5 / Typ 591... .5

b = 3 / 4 / 5 mm ... **450**

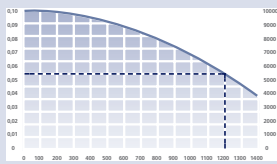

Technische Hinweise

Technical Instructions

**Seite
page**

Grundsätzliche Informationen
zum Gewindefräsen

basic informations about
thread milling

... **451**

Hartmetallsorten und
Beschichtungen

Carbide grades and coatings

...**453**

Ermittlung der Schnittdaten

evaluation of the cutting data

...**455**

Schnittdaten

cutting data

... **457**

SYSTEM 500

Nut- und Trennfräsen

groove milling
and slotting cutter

Allgemeine Beschreibung

general instruction

Sehr scharf geschliffene dreischneidige Wendeschneidplatten garantieren beste Ergebnisse auch bei hochfesten Materialien.

extremely sharp grinded inserts with three-cutting edges guarantees best results, even at high-strength materials.

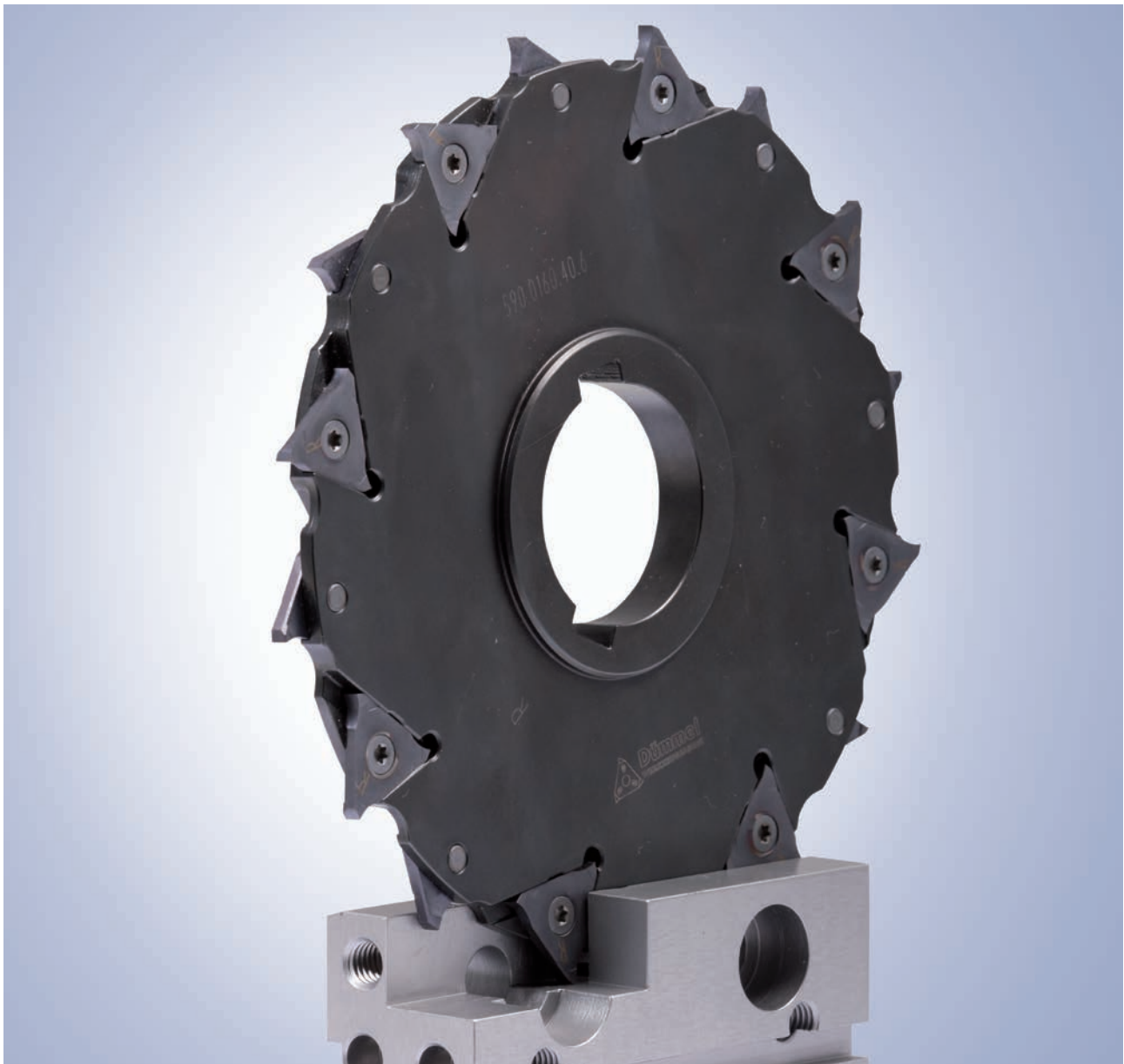

SYSTEM 500

Nut- und Trennfräsen

groove milling
and slotting cutter

Typ 500.44.3

Frälerschaft

D min. 45 mm
t max. 4.0

milling shank

D min. 45 mm
t max. 4.0

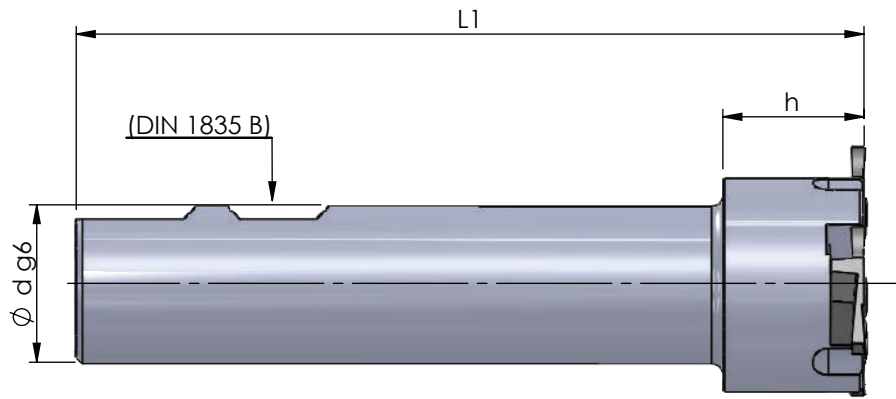
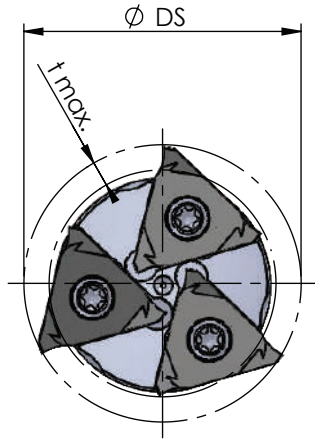

Abmessungen in mm

dimensions in mm

Bestellnummer part number	Ø DS	Ø d g6	t max.	L1	h	Schneidenzahl number of cutting edges	Spannschraube screw	Schraubenschlüssel wrench	Anzugs- drehmoment torque	für Schneidplatten for insert
500.44.3	44	25	4	125	22.4	3	85.818	TX-20/80	3.0 Nm	514....

Achtung:
Frälerschaft ist ohne Schneidplatten!

attention:
Milling shank is without inserts!

Bestellbeispiel:
500.44.3

order-example:
500.44.3

SYSTEM 500

Nut- und Trennfräsen

groove milling
and slotting cutter

Typ 510.0063.05-D

Messerkopf

milling cutter

D min. 64 mm
t max. 5.0

D min. 64 mm
t max. 5.0

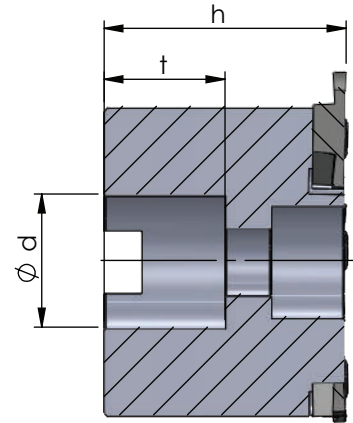
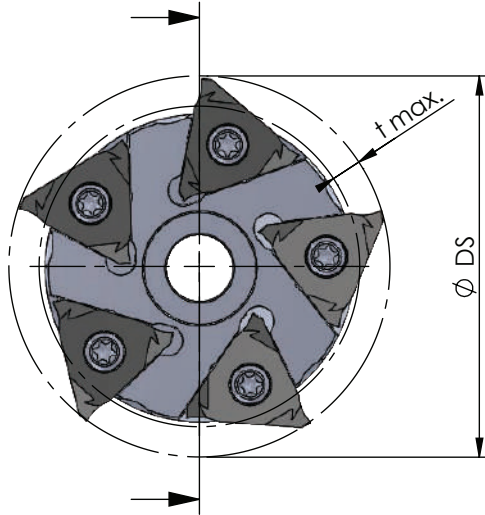

Abmessungen in mm

dimensions in mm



Bestellnummer part number	Ø DS	Ø d x t	t max.	h	Schneidenzahl number of cutting edges	Spannschraube screw	Schraubenschlüssel wrench	Anzugs- drehmoment torque	für Schneidplatten for insert
510.0063.05-D	63	Ø22 x 20	5	40	5	85.818	TX-20/80	3.0 Nm	514....

Achtung:
Messerkopf ist ohne Schneidplatten!

attention:
Milling cutter is without inserts!

Bestellbeispiel:
510.0063.05-D

order-example:
510.0063.05-D

SYSTEM 500

Nut- und Trennfräsen

groove milling
and slotting cutter

Typ 510.0080.08-D

Messerkopf

D min. 81 mm
t max. 5.0

milling cutter

D min. 81 mm
t max. 5.0

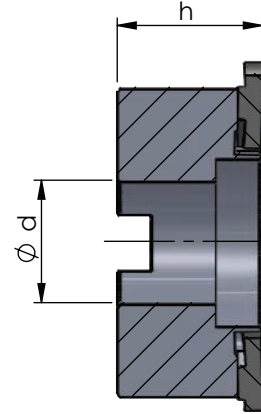
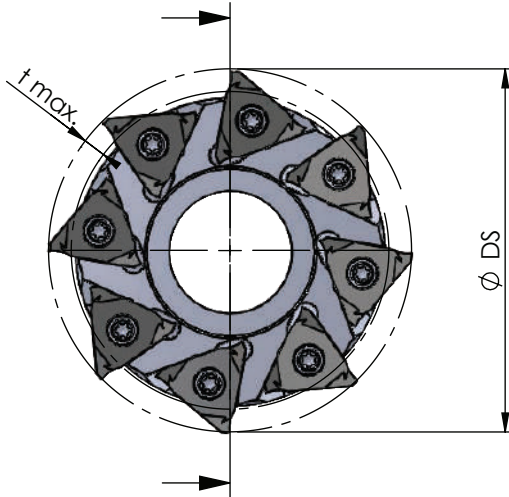

Abmessungen in mm

dimensions in mm

Bestellnummer part number	Ø DS	Ø d	t max.	h	Schneidenzahl number of cutting edges	Spannschraube screw	Schraubenschlüssel wrench	Anzugs- drehmoment torque	für Schneidplatten for insert
510.0080.08-D	80	27	5	32	8	85.818	TX-20/80	3.0 Nm	514....

Achtung:
Messerkopf ist ohne Schneidplatten!

attention:
Milling cutter is without inserts!

Bestellbeispiel:
510.0080.08-D

order-example:
510.0080.08-D

SYSTEM 500

Nut- und Trennfräsen

groove milling
and slotting cutter

Typ 581

Messerkopf

milling cutter

D min. 64 mm
t max. 5.0

D min. 64 mm
t max. 5.0

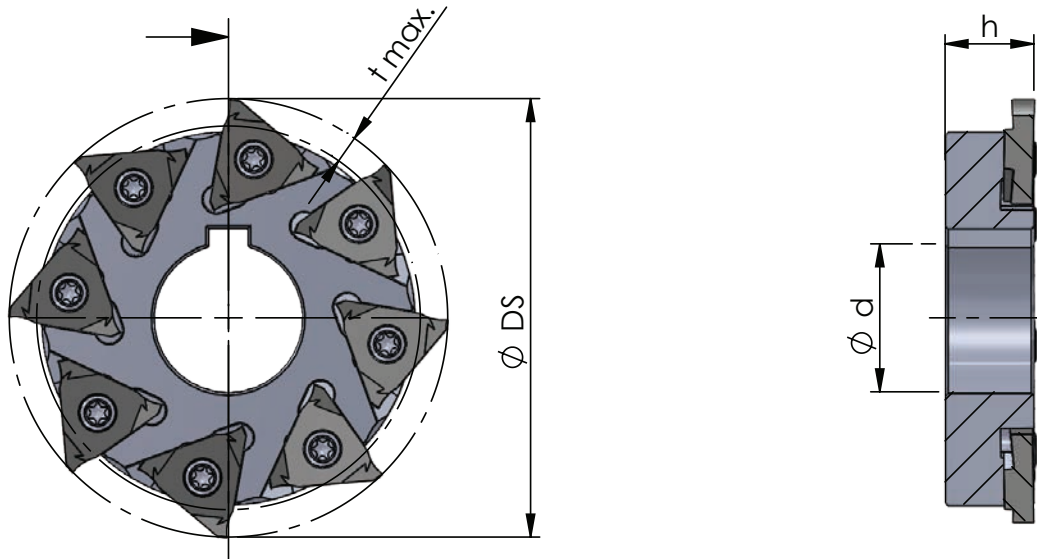

Abmessungen in mm

dimensions in mm

Bestellnummer part number	Ø DS	Ø d	t max.	h	Schneidenzahl number of cutting edges	Spannschraube screw	Schraubenschlüssel wrench	Anzugs- drehmoment torque	für Schneidplatten for insert
581.0063.05-D	63	22	5	14.2	5	85.818	TX-20/80	3.0 Nm	514....
581.0080.08-D	80	27	5	16.2	8				
581.0100.10-D	100	32	5	20.2	10				

Achtung:
Messerkopf ist ohne Schneidplatten!

attention:
Milling cutter is without inserts!

Bestellbeispiel:
581.0063.05-D

order-example:
581.0063.05-D

SYSTEM 500

Nut- und Trennfräsen

groove milling
and slotting cutter

Typ 514

Fräswendeschnidplatte,
für Sicherungsringe DIN 471 / 472

indexable milling insert,
for circlip groove DIN 471 / 472

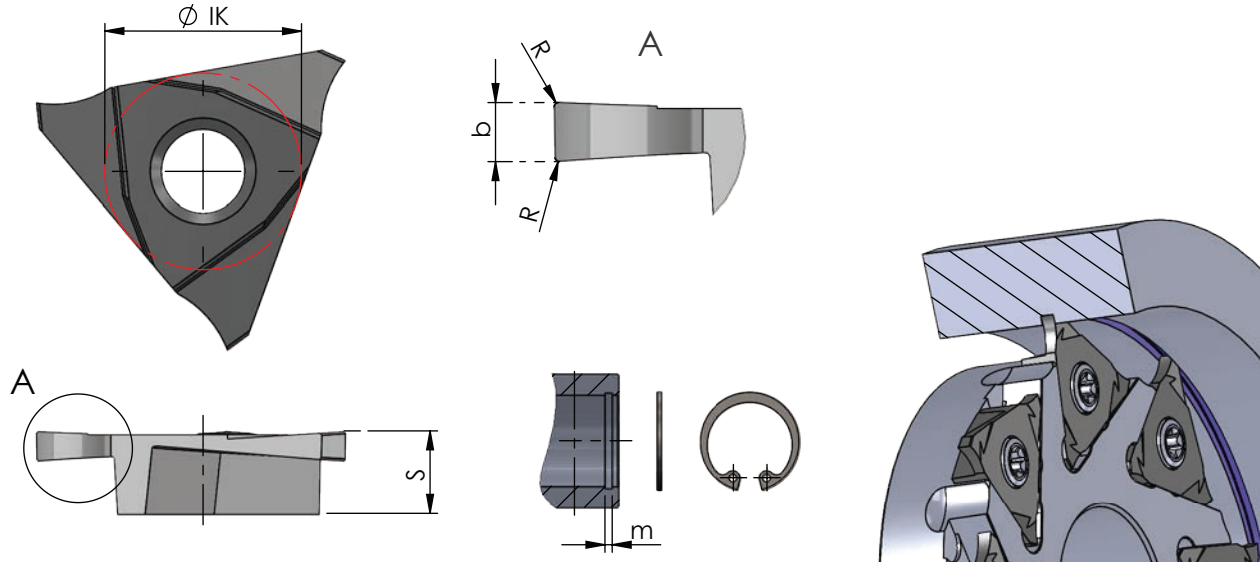

Abmessungen in mm

dimensions in mm

Bestellnummer part number	Nut-Maß m groove dim. m DIN 471 / DIN 472		S	b -0.02	R	Ø IK -0.03	K10F	AL41F	CN45F	für Frärschaft / Messerkopf for milling shank / milling cutter
514.0130.00	1.3	⊙	5.4	1.41	0.1	13	●	●	●	500... 510... 581...
514.0160.00	1.6	⊙	5.4	1.71	0.15	13	●	●	●	
514.0185.00	1.85	⊙	5.4	1.96	0.15	13	●	●	●	
514.0215.00	2.15	⊙	5.4	2.26	0.15	13	●	●	●	
514.0265.00	2.65	⊙	5.4	2.76	0.15	13	●	●	●	
514.0315.00	3.15	⊙	5.4	3.26	0.15	13	●	●	●	
514.0415.00	4.15	⊙	5.4	4.26	0.15	13	●	●	●	
514.0515.00	5.15	⊙	5.4	5.26	0.15	13	●	●	●	

Weitere HM Sorten können Sie in der Sortenübersicht im Kapitel "Technische Hinweise" und der Preisliste finden.

Bestellbeispiel für Sorte AL41F:
Rechts: 514.0130.00/AL41F
Links: L514.0130.00/AL41F (auf Anfrage)

More carbide grades you can find in the grades summary in the chapter "technical instructions" and in the price list.

order-example grade AL41F:
right: 514.0130.00/AL41F
left: L514.0130.00/AL41F (on demand)

SYSTEM 500

Nut- und Trennfräsen

groove milling
and slotting cutter

Typ 514

Fräswendeschnidplatte,
für Sicherungsringe DIN 471 / 472,
mit Nutaußenkantenfasung

indexable milling insert,
for circlip groove DIN 471 / 472,
with chamfer

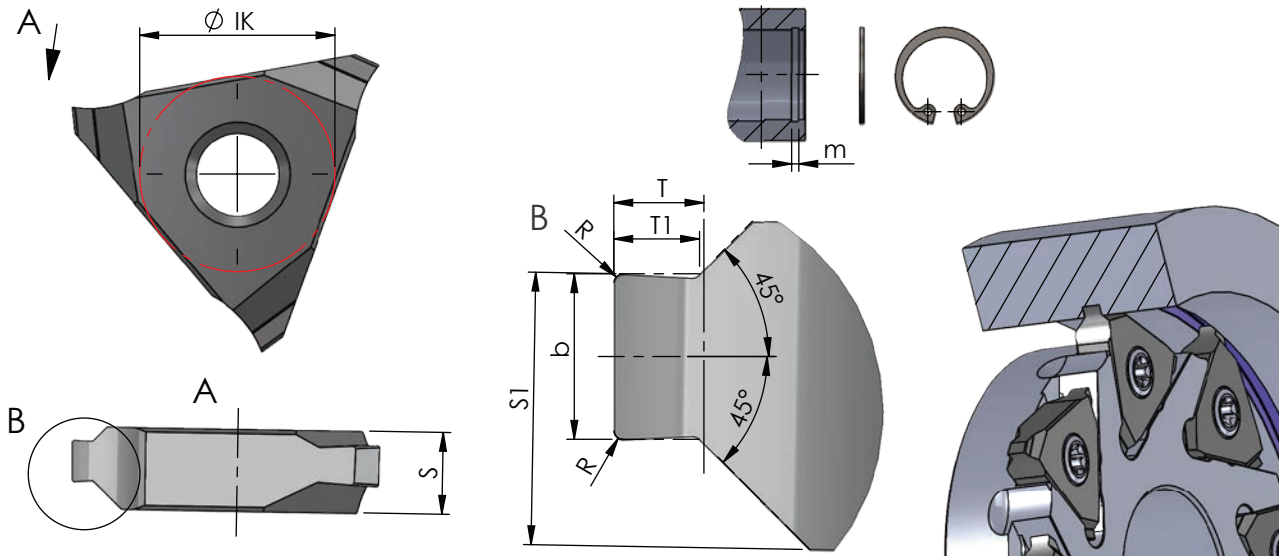

Abmessungen in mm

dimensions in mm



Bestellnummer part number	Nut-Maß m groove dim. m DIN 471 / DIN 472	S	S1 ±0.01	b -0.02	R	T1 -0.04 Formtiefe depth of form	T	Ø IK -0.03	K10F AL41F CN45F	für Fräseschaft / Messerkopf for milling shank / milling cutter
514.1105.35	1.1	5.4	4.52	1.21	0.1	0.49	0.50	13	● ● ●	500... 510... 581...
514.1307.35	1.3	5.4	4.62	1.41	0.1	0.67	0.70	13	● ● ●	
514.1308.35	1.3	5.4	4.62	1.41	0.1	0.83	0.85	13	● ● ●	
514.1609.35	1.6	5.4	4.52	1.71	0.15	0.83	0.85	13	● ● ●	
514.1610.35	1.6	5.4	4.52	1.71	0.15	0.97	1.00	13	● ● ●	
514.1812.35	1.85	5.4	4.64	1.96	0.15	1.23	1.25	13	● ● ●	
514.2115.43	2.15	5.4	4.79	2.26	0.15	1.47	1.50	13	● ● ●	
514.2616.43	2.65	5.4	4.54	2.76	0.15	1.47	1.50	13	● ● ●	
514.2617.43	2.65	5.4	4.54	2.76	0.15	1.72	1.75	13	● ● ●	
514.3118.53	3.15	5.4	4.79	3.26	0.15	1.72	1.75	13	● ● ●	
514.4120.53	4.15	5.4	4.99	4.26	0.15	1.97	2.00	13	● ● ●	
514.4125.53	4.15	5.4	4.99	4.26	0.15	2.47	2.50	13	● ● ●	
514.5130.61	5.15	6.1	5.85	5.26	0.15	2.97	3.00	13	● ● ●	

Weitere HM Sorten können Sie in der Sortenübersicht im Kapitel "Technische Hinweise" und der Preisliste finden.

Bestellbeispiel für Sorte AL41F:
Rechts: 514.1105.35/AL41F
Links: L514.1105.35/AL41F (auf Anfrage)

More carbide grades you can find in the grades summary in the chapter "technical instructions" and in the price list.

order-example grade AL41F:
right: 514.1105.35/AL41F
left: L514.1105.35/AL41F (on demand)

SYSTEM 500

Nut- und Trennfräsen

groove milling
and slotting cutter

Typ 514

Fräswendeschnleidplatte,
für metrisches ISO-Gewinde,
Teilprofil, innen

indexable milling insert,
metric ISO-thread,
partial profile, internal

Steigung P = 1.5 - 6.0

pitch P = 1.5 - 6.0

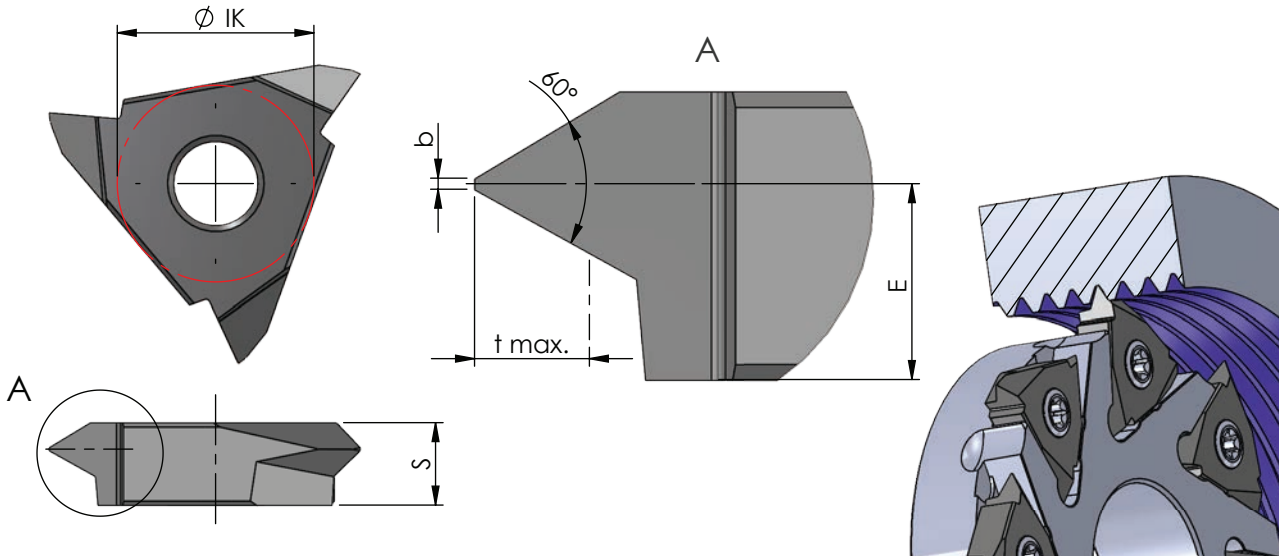

Abmessungen in mm

dimensions in mm

Bestellnummer part number	Steigung P pitch P	S	E	b	t max.	Ø IK -0.03	K10F	AL41F	P18C	für Fräseschaft / Messerkopf for milling shank / milling cutter
514.0815.01	1.5-1.5	5.4	4.60	0.19	0.81	13	●			
514.1020.01	2.0-2.0	5.4	4.40	0.25	1.08	13	●			
514.1535.01	1.5-3.5	5.4	3.90	0.18	1.89	13	●			
514.2140.01	3.5-4.0	5.4	3.70	0.43	2.17	13	●			500...
514.2445.01	3.75-4.5	5.4	3.40	0.47	2.44	13	●			510...
514.2750.01	4.0-5.0	5.4	3.35	0.50	2.70	13	●			581...
514.3260.01	4.5-6.0	5.4	3.00	0.56	3.25	13	●			
514.4060.01	3.5-6.0	5.4	3.00	0.44	3.52	13	●			

Weitere HM Sorten können Sie in der Sortenübersicht im Kapitel "Technische Hinweise" und der Preisliste finden.

Bestellbeispiel:
für Sorte AL41F:
514.0815.01/AL41F

More carbide grades you can find in the grades summary in the chapter "technical instructions" and in the price list.

order-example:
grade AL41F:
514.0815.01/AL41F

SYSTEM 500

Nut- und Trennfräsen

groove milling
and slotting cutter

Typ 514

Fräswendeschnidplatte,
für metrisches ISO-Gewinde,
Vollprofil, innen

indexable milling insert,
metric ISO-thread,
full profile, internal

Steigung P = 1.5 - 5.5

pitch P = 1.5 - 5.5

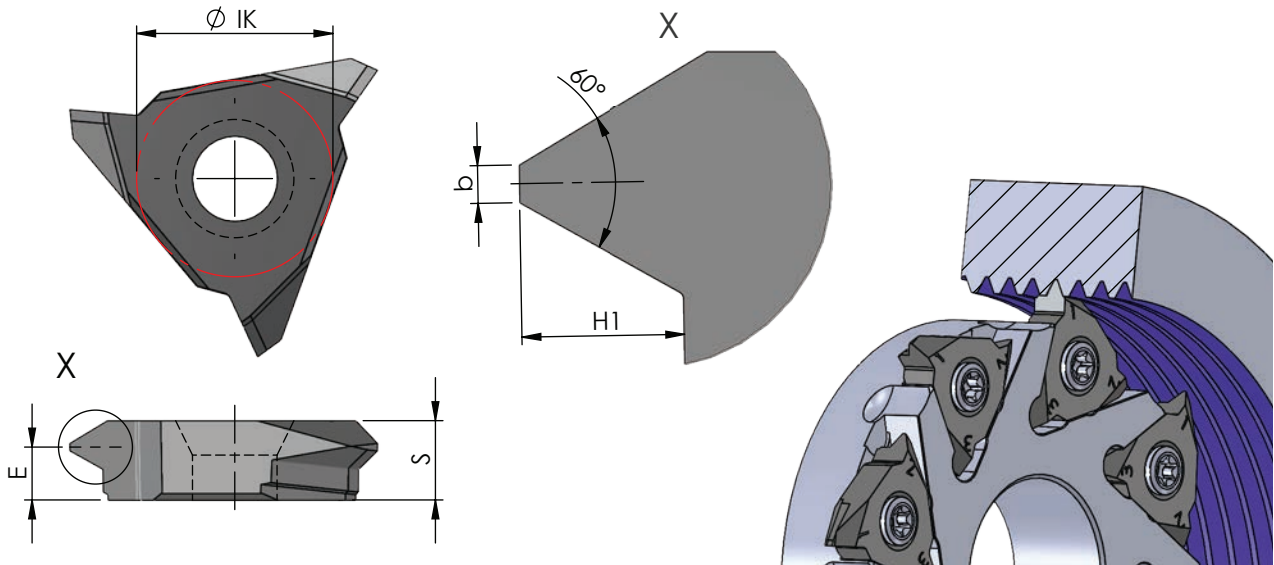

Abmessungen in mm

dimensions in mm



Bestellnummer part number	Steigung P pitch P	S	E	b	H1	Ø IK -0.03	K10F AL41F P18C	für Fräserchaft / Messerkopf for milling shank / milling cutter
514.0815.02	1.5	5.25	4.4	0.19	0.81	13	●	
514.1020.02	2.0	5.25	4.2	0.25	1.08	13	●	
514.1630.02	3.0	5.25	3.9	0.38	1.62	13	●	
514.1835.02	3.5	5.25	3.7	0.44	1.89	13	●	500...
514.2140.02	4.0	5.25	3.5	0.5	2.17	13	●	510...
514.2445.02	4.5	5.25	3.3	0.56	2.44	13	●	581...
514.2750.02	5.0	5.85	3.8	0.62	2.71	13	●	
514.2955.02	5.5	5.85	3.6	0.69	2.98	13	●	

Weitere HM Sorten können Sie in der Sortenübersicht im Kapitel "Technische Hinweise" und der Preisliste finden.

Bestellbeispiel:
für Sorte AL41F:
514.0815.02/AL41F

More carbide grades you can find in the grades summary in the chapter "technical instructions" and in the price list.

order-example:
grade AL41F:
514.0815.02/AL41F

SYSTEM 500

Nut- und Trennfräsen

groove milling
and slotting cutter

Typ 590... .6 / .8 / .10

Hochleistungsscheibenfräser
mit Bohrung und
Längsnut nach DIN 138

high performance
disk-milling cutter with bore
and longitudinal keyway
according DIN 138

Nutbreite b 6 / 8 / 10 mm
Nuttiefe t max. 50 mm
Schneidkreis-Ø Ds ab 80 mm

width of groove b 6 / 8 / 10 mm
depth of groove t max. 50 mm
cutting edge-Ø Ds starting at 80 mm

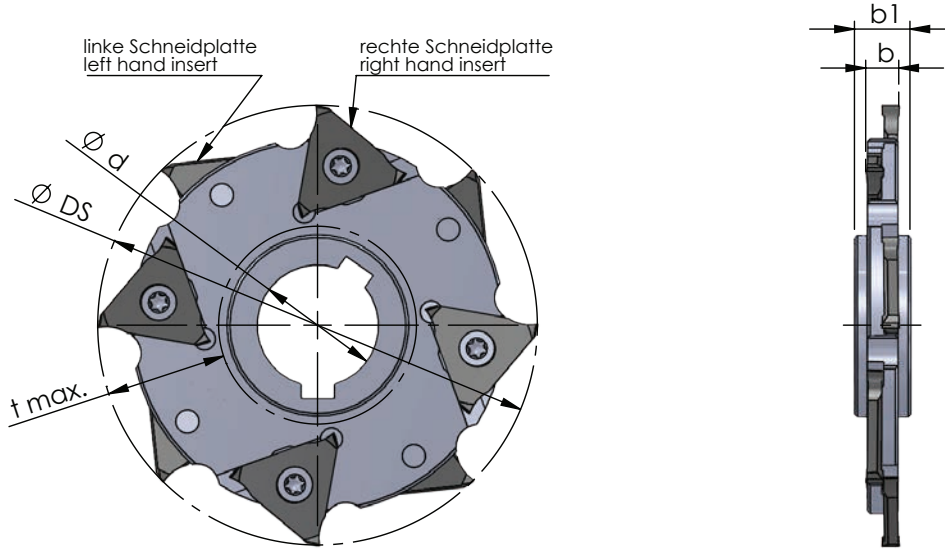

weitere Abmessungen auf
Anfrage

further sizes upon request

Abmessungen in mm

dimensions in mm

Bestellnummer part number	Ø DS	Ø d	b	b1	t max.	Spannschraube screw	Schraubenschlüssel key driver	Anzugs- drehmoment torque	Anzahl Schneidplatten R/L number inserts R/L	Schneidplatte insert type
590.0080.22.6	80	22	6	10	22	5.06.25F	Tr15	2.0	4/4	R/L 514.0632.00
590.0080.27.6	80	27	6	10	21	5.06.25F	Tr15	2.0	4/4	R/L 514.0632.00
590.0080.27.8	80	27	8	12	21	5.08.25F	Tr20	2.8	4/4	R/L 514.0843.00
590.0080.27.10	80	27	10	12	21	5.10.25	Tr20	3.0	4/4	R/L 514.1054.00
590.0100.32.6	100	32	6	10	25.5	5.06.25F	Tr15	2.0	5/5	R/L 514.0632.00
590.0100.32.8	100	32	8	12	25.5	5.08.25F	Tr20	2.8	5/5	R/L 514.0843.00
590.0100.32.10	100	32	10	12	25.5	5.10.25	Tr20	3.0	5/5	R/L 514.1054.00
590.0125.40.6	125	40	6	10	32.5	5.06.25F	Tr15	2.0	6/6	R/L 514.0632.00
590.0125.40.8	125	40	8	12	32.5	5.08.25F	Tr20	2.8	6/6	R/L 514.0843.00
590.0125.40.10	125	40	10	14	32.5	5.10.25	Tr20	3.0	6/6	R/L 514.1054.00
590.0160.40.6	160	40	6	10	50	5.06.25F	Tr15	2.0	8/8	R/L 514.0632.00
590.0160.40.8	160	40	8	12	50	5.08.25F	Tr20	2.8	8/8	R/L 514.0843.00
590.0160.40.10	160	40	10	14	50	5.10.25	Tr20	3.0	8/8	R/L 514.1054.00

Achtung:
Scheibenfräser ist ohne Schneidplatten!

attention:
disk-milling cutter is without inserts!

Bestellbeispiel:
590.0080.22.6

order-example:
590.0080.22.6

SYSTEM 500

Nut- und Trennfräsen

groove milling
and slotting cutter

Typ 591... .6

Hochleistungs
Aufsteck-Scheibenfräser

high performance
arbour mounted
disk-milling cutter

Nutbreite b 6 mm
Nuttiefe t max. 37.5 mm
Schneidkreis-Ø Ds 125 mm

width of groove b 6 mm
depth of groove t max. 37.5 mm
cutting edge-Ø Ds 125 mm

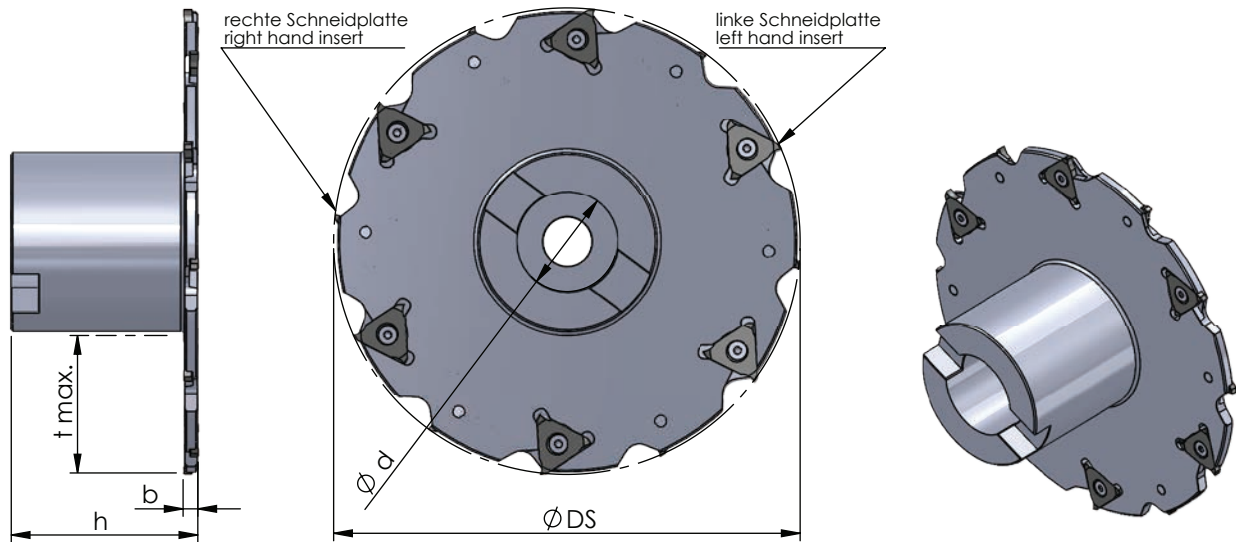

weitere Abmessungen auf
Anfrage

further sizes upon request

Abmessungen in mm

dimensions in mm



Bestellnummer part number							Spannschraube screw	Schraubenschlüssel wrench	Anzugs- drehmoment torque	Befestigung/fixing		Anzahl Schneidplatten R/L number inserts R/L	Schneidplatte insert type
	Ø DS	Ø d	b	Ø d1	h	t max.				Spannschraube screw	Unterleg- scheibe washer		
591.0125.27.6	125	27	6	48	50	37.5	5.06.25F	Tr15	2.0	DIN 912 M12x35	DIN 433- 13-2	6/6	R/L 514.0632.00

Achtung:
Scheibenfräser ist ohne Schneidplatten!

attention:
disk-milling cutter is without inserts!

Bestellbeispiel:
591.0125.27.6

order-example:
591.0125.27.6

SYSTEM 500

Nut- und Trennfräsen

groove milling
and slotting cutter

Typ 514

Fräswendeschnidplatte

indexable milling insert

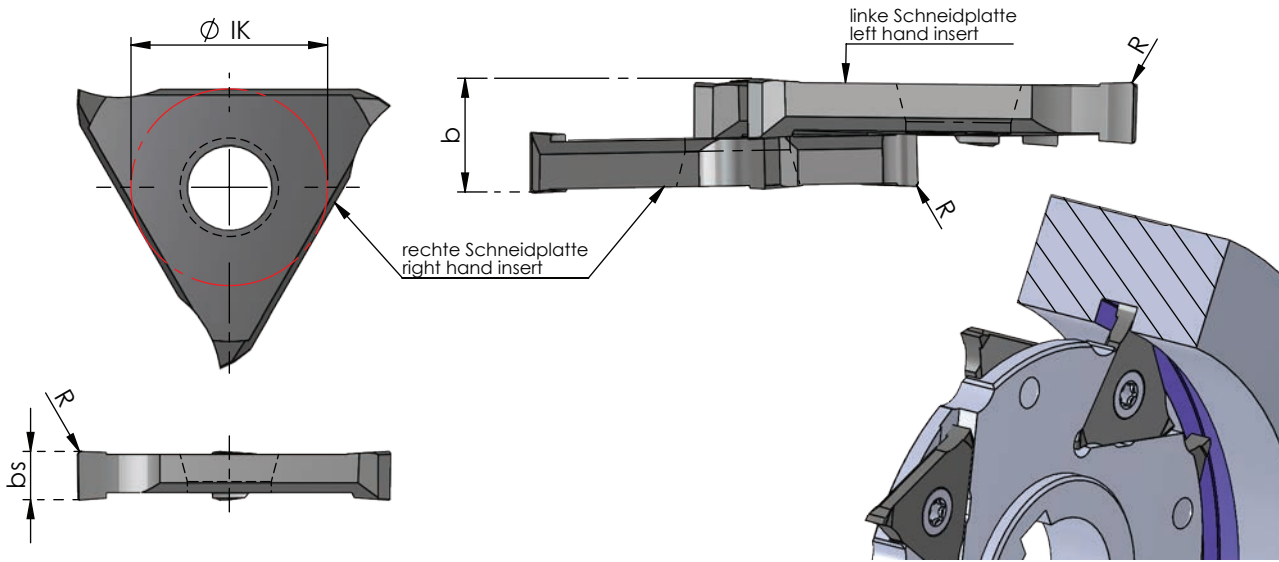

Rechts (R): wie gezeichnet
Links (L): spiegelbildlich

righthand (R): as shown
lefthand (L): mirror image

Abmessungen in mm

dimensions in mm

Bestellnummer part number	b für Nutbreite b width of groove	bs	R	$\varnothing IK$	K10F AL41F CN45F	für Scheibenfräser for disk milling cutter
R/L 514.0632.00	6	3.2	0.2	13	● ● ●	
R/L 514.0843.00	8	4.3	0.2	13	● ● ●	590... 591...
R/L 514.1054.00	10	5.4	0.2	13	● ● ●	

Weitere HM Sorten können Sie in der Sortenübersicht im Kapitel "Technische Hinweise" und der Preisliste finden.

More carbide grades you can find in the grades summary in the chapter "technical instructions" and in the price list.

Bestellbeispiel:
für rechte Ausführung und Sorte
R514.0632.00/AL41F

order-example:
righthand version and grade
R514.0632.00/AL41F

SYSTEM 500

Nut- und Trennfräsen

groove milling
and slotting cutter

Typ 590... .3 / .4 / .5

Hochleistungstrennfräser
mit Bohrung und
Längsnut nach DIN 138

high performance
slotting cutter with bore
and longitudinal keyway
according DIN 138

Nutbreite b 3 / 4 / 5 mm
Nuttiefe t max. 50 mm
Schneidkreis-Ø Ds ab 80 mm

width of groove b 3 / 4 / 5 mm
depth of groove t max. 50 mm
cutting edge-Ø Ds starting at 80 mm

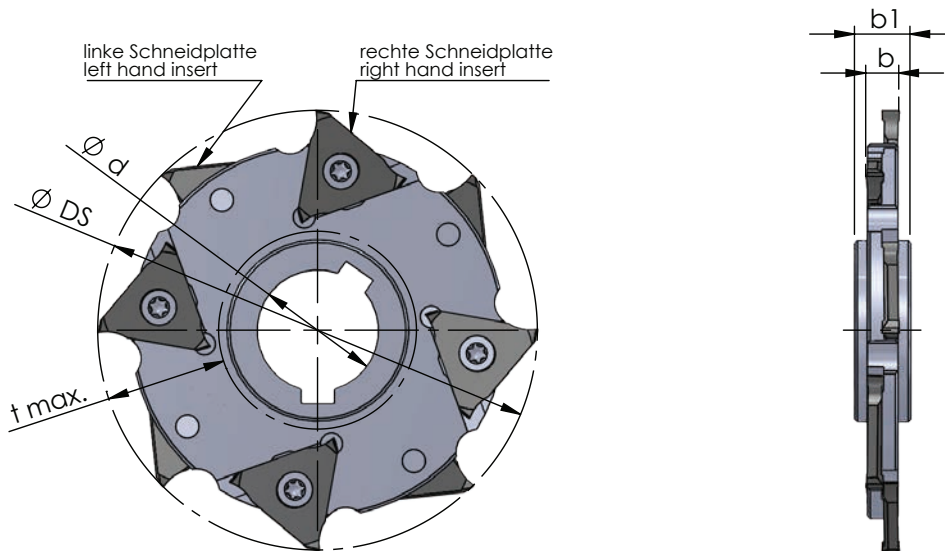

weitere Abmessungen auf
Anfrage

further sizes upon request

Abmessungen in mm

dimensions in mm



Bestellnummer part number	Ø DS	Ø d	b	b1	t max.	Spannschraube screw	Schraubenschlüssel key driver	Anzugs- drehmoment torque	Anzahl Schneidplatten R/L number inserts R/L	Schneidplatte insert type
590.0080.27.3	80	27	3	8	18	025.03F	DSD-TX7/07	0.7	4/4	R/L 510.0317
590.0100.32.3	100	32	3	8	25	025.03F	DSD-TX7/07	0.7	5/5	R/L 510.0317
590.0125.40.3	125	40	3	10	32	025.03F	DSD-TX7/07	0.7	6/6	R/L 510.0317
590.0160.40.3	160	40	3	10	50	025.03F	DSD-TX7/07	0.7	8/8	R/L 510.0317
590.0080.27.4	80	27	4	8	18	035.04F	TR8	1.3	4/4	R/L 510.0423
590.0100.32.4	100	32	4	8	25	035.04F	TR8	1.3	5/5	R/L 510.0423
590.0125.40.4	125	40	4	10	32	035.04F	TR8	1.3	6/6	R/L 510.0423
590.0160.40.4	160	40	4	10	50	035.04F	TR8	1.3	8/8	R/L 510.0423
590.0080.27.5	80	27	5	8	18	035.05F	TR8	1.3	4/4	R/L 510.0528
590.0100.32.5	100	32	5	8	25	035.05F	TR8	1.3	5/5	R/L 510.0528
590.0125.40.5	125	40	5	10	32	035.05F	TR8	1.3	6/6	R/L 510.0528
590.0160.40.5	160	40	5	10	50	035.05F	TR8	1.3	8/8	R/L 510.0528

Achtung:
Trennfräser ist ohne Schneidplatten!

attention:
slotting cutter is without inserts!

Bestellbeispiel:
590.0080.27.3

order-example:
590.0080.27.3

SYSTEM 500

Nut- und Trennfräsen

groove milling
and slotting cutter

Typ 591... .3

Hochleistungs Aufsteck-Trennfräser
mit Bohrung und
Quernut nach DIN 138

high performance arbour mounted
slotting cutter with bore and cross
keyway according DIN 138

Nutbreite b 3 mm
Nuttiefe t max. 44 mm
Schneidkreis-Ø Ds ab 63 mm

width of groove b 3 mm
depth of groove t max. 44 mm
cutting edge-Ø Ds starting at 63 mm

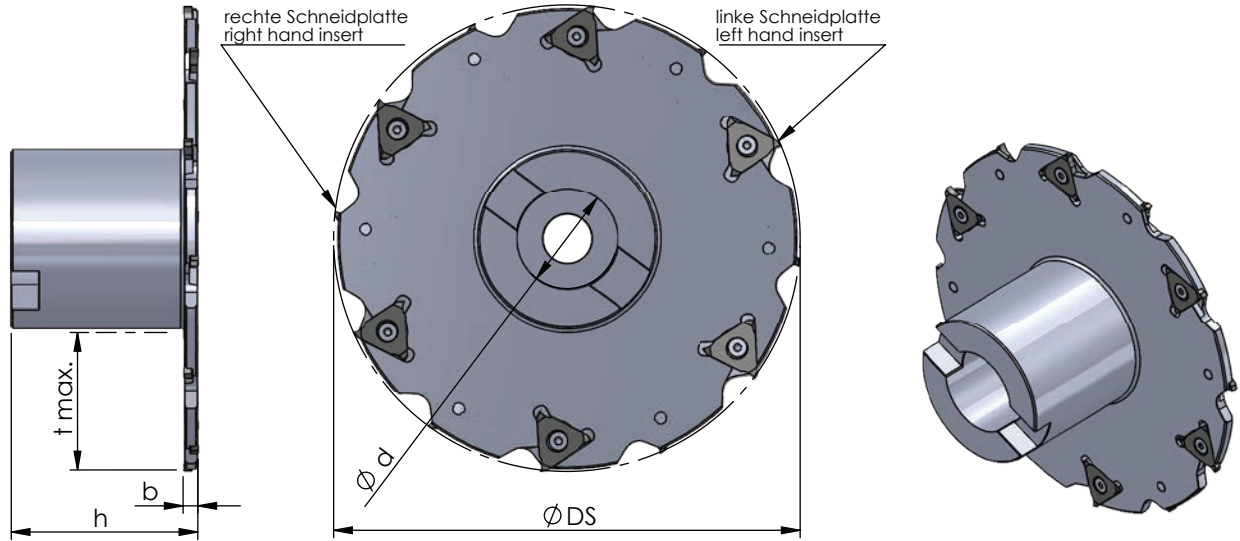

weitere Abmessungen auf
Anfrage

further sizes upon request

Abmessungen in mm

dimensions in mm

Bestellnummer part number	Ø DS	Ø d	b	Ø d1	h	t max.	Spannschraube screw	Schraubenschlüssel wrench	Anzugs- drehmoment torque	Befestigung/fixing		Anzahl Schneidplatten R/L number inserts R/L	Schneidplatte insert type
										Spannschraube screw	Unterleg- scheibe washer		
591.0063.16.3	63	16	3	27	50	17.5	025.03F	DSD- TX7/07	0.7 Nm	DIN 912-	DIN125-	4/4	R/L 510.0317
591.0080.16.3	80	16	3	28	50	25				M8 x 40	8.4/5	4/4	
591.0100.27.3	100	27	3	48	50	25				DIN 912-	DIN433-	5/5	
591.0125.27.3	125	27	3	48	50	37.5				M12 x 35	13-2	6/6	
591.0160.40.3	160	40	3	70	50	44				M20 x 40	DIN433- 21-3	8/8	

Achtung:
Trennfräser ist ohne Schneidplatten!

attention:
slotting cutter is without inserts!

Bestellbeispiel:
591.0063.16.3

order-example:
591.0063.16.3

SYSTEM 500

Nut- und Trennfräsen

groove milling
and slotting cutter

Typ 591... .4

Hochleistungs Aufsteck-Trennfräser
mit Bohrung und
Quernut nach DIN 138

high performance arbour mounted
slotting cutter with bore and cross
keyway according DIN 138

Nutbreite b 4 mm
Nuttiefe t max. 64 mm
Schneidkreis-Ø Ds ab 63 mm

width of groove b 4 mm
depth of groove t max. 64 mm
cutting edge-Ø Ds starting at 63 mm

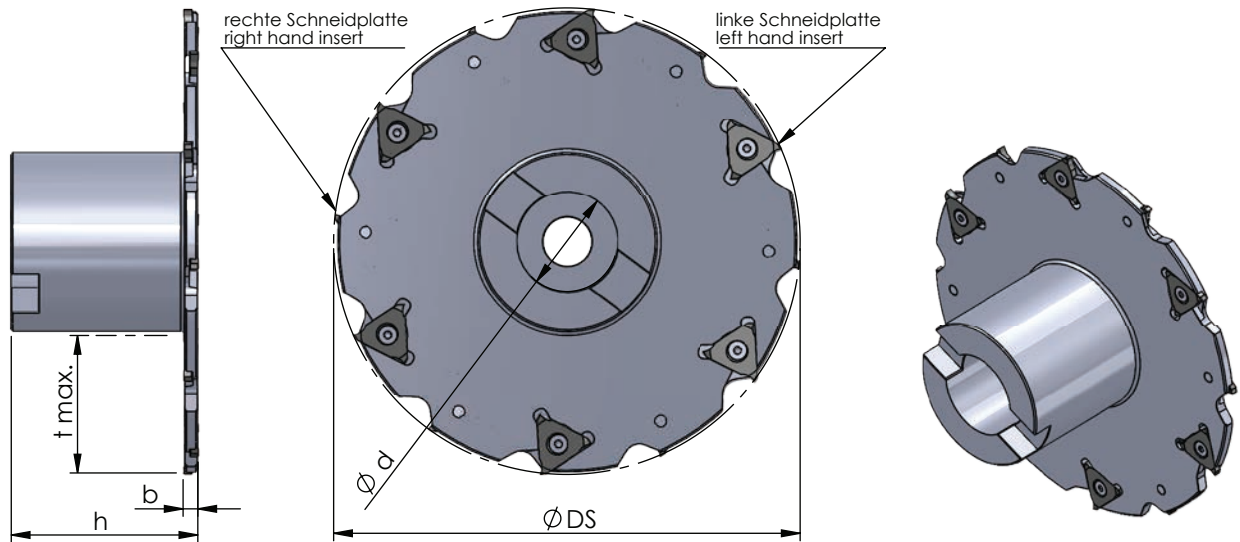

weitere Abmessungen auf
Anfrage

further sizes upon request

Abmessungen in mm

dimensions in mm



Bestellnummer part number	Ø DS	Ø d	b	Ø d1	h	t max.	Spannschraube screw	Schraubenschlüssel wrench	Anzugs- drehmoment torque	Befestigung/fixing		Anzahl Schneidplatten R/L number inserts R/L	Schneidplatte insert type
										Spannschraube screw	Unterleg- scheibe washer		
591.0063.16.4	63	16	4	27	50	17.5	035.04F	TR8	1.3 Nm	DIN 912- M8 x 40	DIN125- 8.4/5	4/4	R/L 510.0423
591.0080.16.4	80	16	4	28	50	25				4/4			
591.0100.27.4	100	27	4	48	50	25				DIN 912- M12 x 35	DIN433- 13-2	5/5	
591.0125.27.4	125	27	4	48	50	37.5				6/6			
591.0125.40.4	125	40	4	70	50	26.5				DIN 912- M20 x 40	DIN433- 21-3	6/6	
591.0160.27.4	160	4	48	50	55	DIN 912- M12 x 35				DIN433- 13-2	8/8		
591.0160.40.4	160	4	70	50	44	8/8							
591.0180.40.4	180	4	70	50	54	DIN 912- M20 x 40				DIN433- 21-3	9/9		
591.0200.40.4	200	4	70	50	64	10/10							

Achtung:
Trennfräser ist ohne Schneidplatten!

attention:
slotting cutter is without inserts!

Bestellbeispiel:
591.0063.16.4

order-example:
591.0063.16.4

SYSTEM 500

Nut- und Trennfräsen

groove milling
and slotting cutter

Typ 591... .5

Hochleistungs Aufsteck-Trennfräser
mit Bohrung und
Quernut nach DIN 138

high performance arbour mounted
slotting cutter with bore and cross
keyway according DIN 138

Nutbreite b 5 mm
Nuttiefe t max. 37.5 mm
Schneidkreis-Ø Ds ab 100 mm

width of groove b 5 mm
depth of groove t max. 37.5 mm
cutting edge-Ø Ds starting at 100 mm

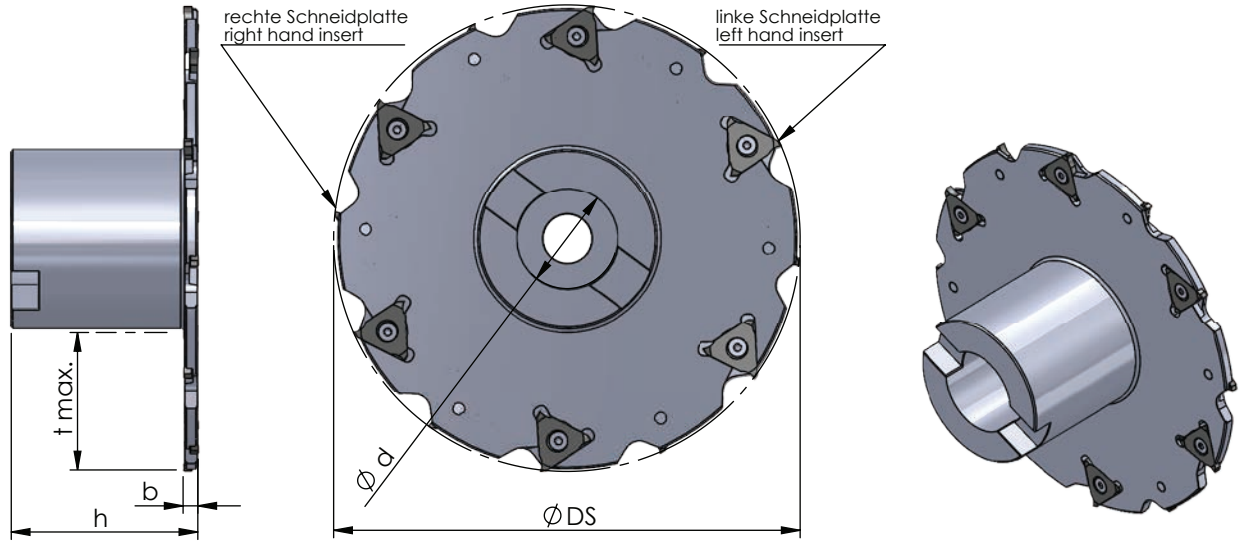

weitere Abmessungen auf
Anfrage

further sizes upon request

Abmessungen in mm

dimensions in mm

Bestellnummer part number	Ø DS	Ø d	b	Ø d1	h	t max.				Befestigung/fixing		Anzahl Schneidplatten R/L number inserts R/L	Schneidplatte insert type
							Spannschraube screw	Schraubenschlüssel wrench	Anzugs- drehmoment torque	Spannschraube screw	Unterleg- scheibe washer		
591.0100.27.5	100	27	5	48	50	25	035.05F	TR8	1.3 Nm	DIN 912-	DIN433-	5/5	R/L 510.0528
591.0125.27.5	125	27	5	48	50	37.5	035.05F	TR8	1.3 Nm	M12 x 35	13-2	6/6	R/L 510.0528

Achtung:
Trennfräser ist ohne Schneidplatten!

attention:
slotting cutter is without inserts!

Bestellbeispiel:
591.0100.27.5

order-example:
591.0100.27.5

SYSTEM 500

Nut- und Trennfräsen

groove milling
and slotting cutter

Typ R/L 510

Fräswendeschnidplatte

indexable milling inset

für Trennfräser Typ 590 und
Aufsteck-Trennfräser Typ 591

for slotting cutter type 590 and
arbor mounted slotting cutter
type 591

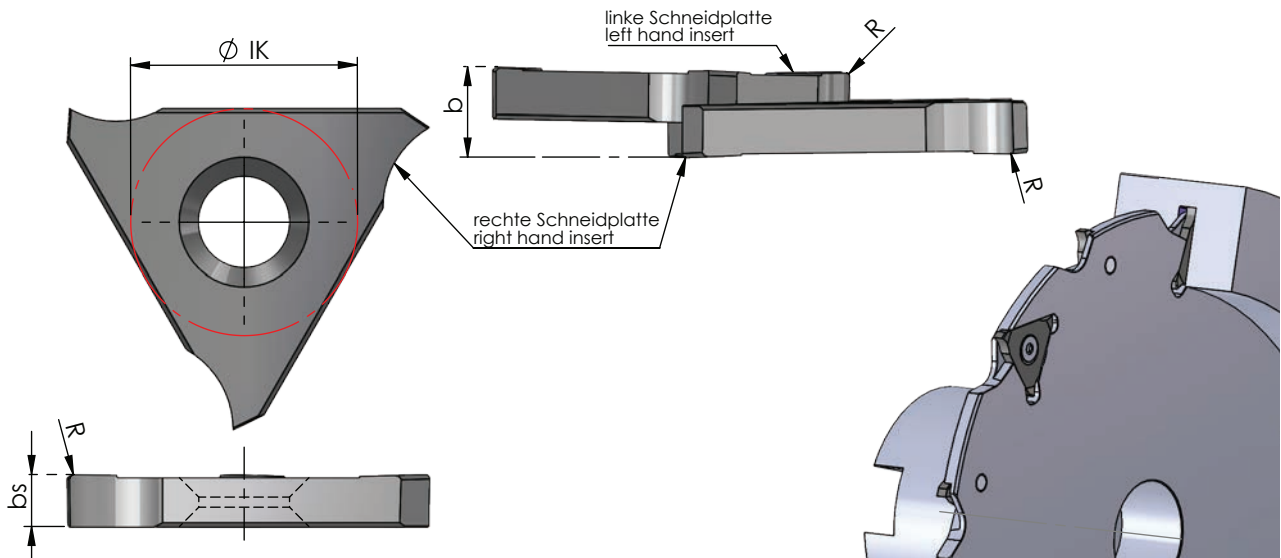

Rechts (R): wie gezeichnet
Links (L): spiegelbildlich

righthand (R): as shown
lefthand (L): mirror image

Abmessungen in mm

dimensions in mm

Bestellnummer part number	b für Nutbreite b width of groove	bs	R	Ø IK	K10F AL41F P18C	für Trennfräser for slotting cutter
R/L 510.0317	3	1.7	0.15	10	● ●	590.....3 591.....3
R/L 510.0423	4	2.3	0.2	10	● ●	590.....4 591.....4
R/L 510.0528	5	2.8	0.2	10	● ●	590.....5 591.....5

Weitere HM Sorten können Sie in der Sortenübersicht im Kapitel "Technische Hinweise" und der Preisliste finden.

Bestellbeispiel:
für Sorte AL41F:
R510.0317/AL41F

More carbide grades you can find in the grades summary in the chapter "technical instructions" and in the price list.

order-example:
grade AL41F:
R510.0317/AL41F

SYSTEM 500

Nut- und Trennfräsen

groove milling
and slotting cutter

Technische Hinweise

Grundsätzliche Informationen zum Gewindefräsen

Technical instructions,
basic informations about thread milling

Vor- und Nachschnitt

Beim Zirkularfräsen von Gewinden entsteht durch die Steigung ein Vor- und Nachschnitt. Um hier die Verletzung des Gewindepfels so gering wie möglich zu halten muß ein Werkzeug mit einem möglichst kleinen Schneidkreis gewählt werden. Die nachfolgende Skizze zeigt die Verhältnisse bei der Bearbeitung:
(Grün: Konturverletzung X gering = gut; Rot: Konturverletzung X erheblich = schlecht)

Thread profile violation

Thread milling by interpolation causes a profile violation. To keep the violation minimal you should use the cutting circle as small as possible.

The following sketch shows the relations during the process:

(green: profile violation X low = good; red: profile violation X big = bad)

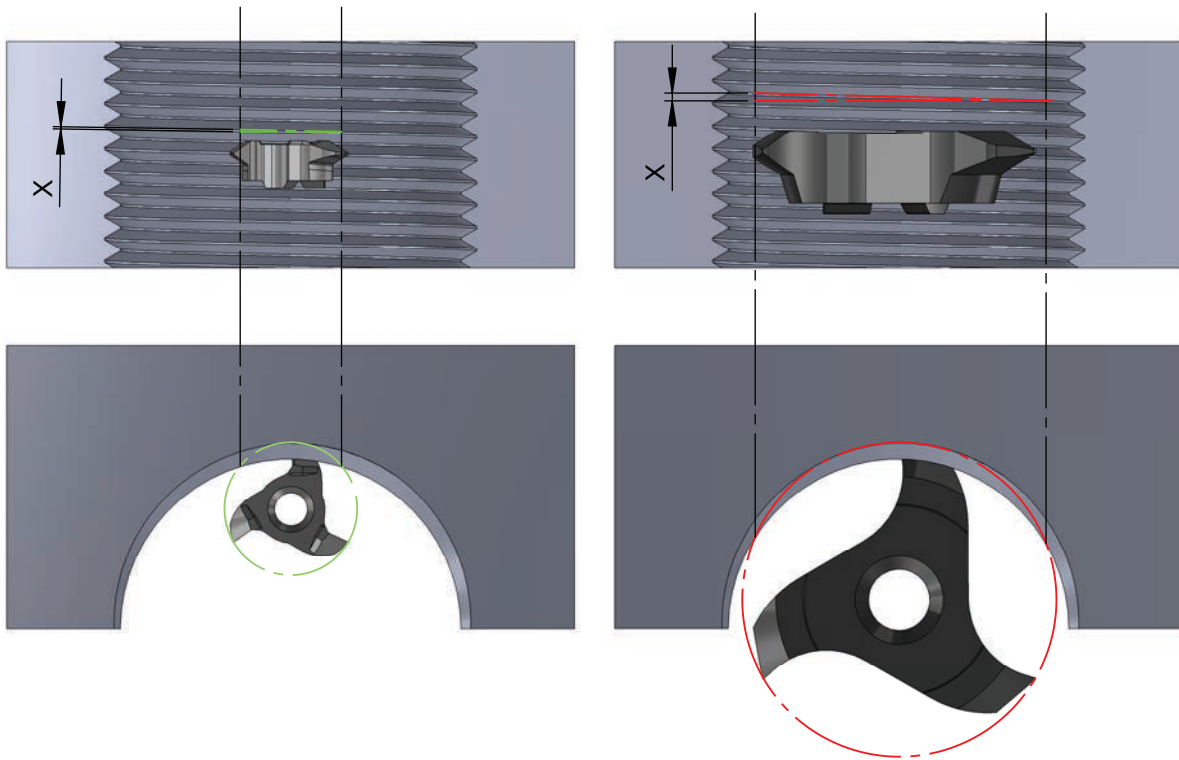

SYSTEM 500

Nut- und Trennfräsen

groove milling
and slotting cutter

Technische Hinweise

Grundsätzliche Informationen zum Gewindefräsen

Technical instructions,
basic informations about thread milling

Teilprofil

Werkzeuge mit Teilprofil sind Mehrbereichswerkzeuge, d.h. mit diesem Werkzeug können Gewinde mit unterschiedlichen Steigungen hergestellt werden. Dies ist aber nur mit einer kleinen Abweichung vom Normprofil möglich. Abgestimmt ist das Werkzeug auf die kleinste angegebene Steigung, dieses Profil kann ohne Abweichung produziert werden. Alle weiteren Steigungen können ebenfalls produziert werden, hier weicht aber das gefertigte Profil gegenüber der Norm durch eine höhere Gewindetiefe ab. In der Regel ist dies unproblematisch, muß aber gegebenenfalls im Einzelfall genauer betrachtet werden.

Partial profile

Tools with partial profile are multi-purpose tools, that means you can process several pitches with one tool. The processed shape has a small difference to the standard profile. Created is that tool for the smallest pitch, this profile depends to the standard.

All other pitches are producible, but only with a small deviation. Normally this causes no problem, but sometimes you have to decide case by case.

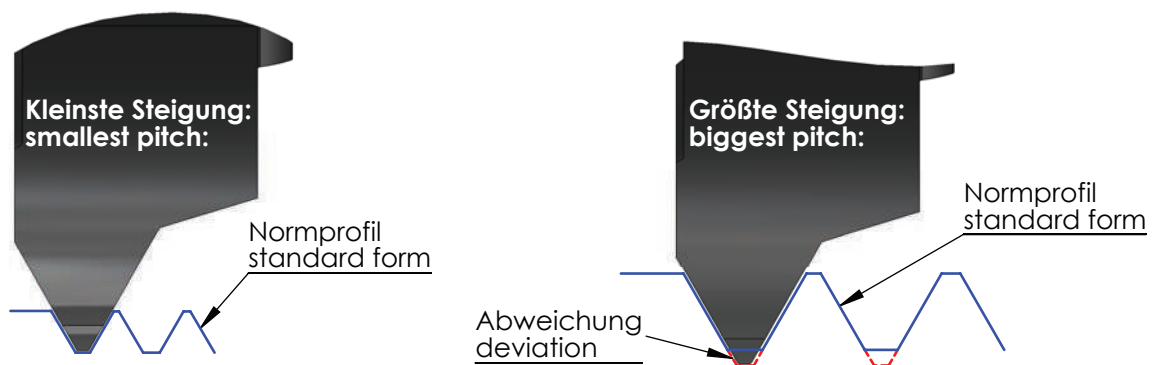

SYSTEM 500

Nut- und Trennfräsen

groove milling
and slotting cutter

Technische Hinweise

Hartmetallsorten und Beschichtungen

Technical instructions,
carbide grades and coatings

K10F

Universell einsetzbares Feinkornhartmetall mit guter Verschleißfestigkeit. Unbeschichtet geeignet für Anwendungen mit niedrigen und mittleren Schnittgeschwindigkeiten, sowie die Bearbeitung von Nicht-eisenmetallen.

All purpose micrograin carbide with good abrasion resistance. Uncoated for applications with low or medium cutting speeds and machining of non-ferrous materials.

CBN

Zähe CBN-Sorte für Anwendungen mit niedrigen Schnittgeschwindigkeiten. Geeignet für gehärtete Stähle, unterbrochene Schnitte und Grauguss.

Ductile CBN grade for applications with lower cutting speed. Suitable for hardened steel, interrupted cuts and cast iron.

CN45F

Universell einsetzbare PVD-TiN-Beschichtung. Diese Allround-Sorte ist für niedrige und mittlere Schnittgeschwindigkeiten mit Einschränkung bei NE-Metallen

PVD-TiN coating - all purpose, all around grade is suitable for low and medium cutting speed with restrictions on non-ferrous materials.

AL41F

Sehr universell einsetzbare TiAlN-Beschichtung mit hoher Temperaturbeständigkeit bei hoher Härte. Sehr gut geeignet auch für NE-Metalle.

TiAlN coating - very universal with a high resistance to high temperature and hardness. Very suitable also for non-ferrous metals.

PD2F

Beschichtung für den universellen Einsatz bei niedrigen und mittleren Schnittgeschwindigkeiten.

Coating for universal use with medium and low speed.

XC2A

Beschichtung mit einer excellenten Warmhärte, Oxidationsbeständigkeit und thermischen Isolationsfähigkeit. Ideal für Hartzerspannung >60HRC

Coating with excellent hot hardness, high oxidation resistance and thermal insulation capacity. Perfect for hard machining >60 HRC.

SYSTEM 500

Nut- und Trennfräsen

groove milling
and slotting cutter

Technische Hinweise

Hartmetallsorten und Beschichtungen

Technical instructions,
carbide grades and coatings

P01C

Beschichtung für die Bearbeitung in zähen Materialien bei niedrigen und mittleren Schnittgeschwindigkeiten.

Coating for the processing in tough material with medium or low cutting speed

P03C

Beschichtung für die Bearbeitung von schwer zerspanbaren Materialien. Sehr gut auch für die Trockenbearbeitung geeignet.

Coating for materials which are difficult to machine. Perfect to use for dry machining.

P07C

Beschichtung für die Bearbeitung von Titan, Edelstahl und Molybdän.

Coating to machine titanium, stainless steel and molybdenum.

P18C

Universell einsetzbare Hochleistungsschicht mit hoher Oxidationsbeständigkeit, Verschleißfestigkeit und Warmhärte.

Very universal high performance coating with high oxidation resistance, wear resistance and hot hardness resistance.

NEME

Beschichtung für die Bearbeitung von Aluminium, Al-Legierungen, NE-Metallen und Composite-Werkstoffen.

Coating for machining aluminium, alloys, non-ferrous metals and composite materials.



SYSTEM 500

Nut- und Trennfräsen

groove milling
and slotting cutter

Technische Hinweise

Ermittlung der Schnittdaten
für das Zirkularfräsen

Technical instructions,
evaluation of the cutting data for groove milling

Fräsen Außenkontur
milling external

Fräsen Innenkontur
milling internal

$$n = \frac{V_c \cdot 1000}{d \cdot \pi} \quad V_{\text{eff}} = f_z \cdot z \cdot n \quad f_z = h_m \sqrt{\frac{d}{a_e}}$$

$$V_{\text{prog}} = \frac{V_{\text{eff}} \cdot (D + d)}{D} \quad V_{\text{eff}} = \frac{D \cdot V_{\text{prog}}}{(D + d)}$$

$$V_{\text{prog}} = \frac{V_{\text{eff}} \cdot (D - d)}{D} \quad V_{\text{eff}} = \frac{D \cdot V_{\text{prog}}}{(D - d)}$$

Formel-Zeichen
formula characters

Bezeichnungen
specifications

Einheit
unit

d

Fräserdurchmesser
milling diameter

mm

D

Gewindedurchmesser
thread diameter

mm

V_{eff}

effektive Vorschubgeschwindigkeit
(auf / an der Kontur)
feed rate of tool tip

mm / min

V_{eint}

programmierter Eintauchvorschub
programmed plunge feed

mm / min

V_{prog}

programmierte Vorschubgeschwindigkeit
feed rate of tool center

mm / min

z

Schneidenzahl Fräser
number of cutting edges

Stk.
pcs.

Nach Möglichkeit immer im Kreisbogen
eintauchen.

Always plunge in a circular arc where possible.

Beim geraden Eintauchen nur 1/3 des Vorschubs
verwenden und erst beim Erreichen der Frästie-
fe vollen Vorschub fahren.

When plunging straight use only 1/3 of the feed
and do not traverse full feed until reaching the
milling depth.

SYSTEM 500

Nut- und Trennfräsen

groove milling
and slotting cutter

Technische Hinweise

Ermittlung der Schnittdaten
für das Trennfräsen

Technical instructions,
evaluation of the cutting data for groove milling
and slotting cutter

$$z = \frac{\text{Fräswendeschnidplatten/} \\ \text{quantity of cutting inserts}}{2}$$

$$n = \frac{V_c \cdot 1000}{d \cdot \pi}$$

$$V_f = n \cdot z \cdot f_z \text{ mm/min}$$

$$f_z = h_m \sqrt{\frac{2r}{a_e}}$$

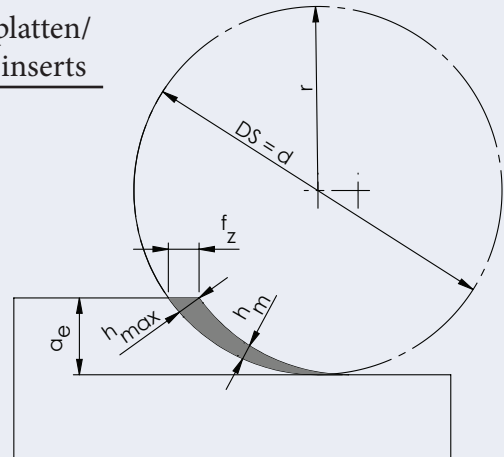

Formel-Zeichen
formula characters

Bezeichnungen
specifications

Einheit
unit

a_e

Spantiefe radial
radial depth of cut

mm

f_z

Vorschub pro Zahn
feed / tooth

mm

h_m

mittlere Spandicke
medium thickness of chip

mm

h_{max}

maximale Spandicke
maximum thickness of chip

mm

n

Spindeldrehzahl
revolutions

U / min

r

Radius Fräser
radius of cutter

mm

V_c

Schnittgeschwindigkeit
cutting speeds

m / min

V_f

Vorschubgeschwindigkeit
feed rate of tool center

mm / min

z

Schneidzahl Fräser
number of cutting edges

Stk.
pcs.

	Werkstoff	Festigkeit	Werkstoff-Nr	Werkstoffbezeichnung	Werkstoff-Nr
P	Allgemeiner Baustahl	< 800 N/mm2	1.0037	St37-2	1.0570
	Automatenstahl	< 800 N/mm2	1.0718	9SMnPb28	1.0727
	Einsatzstahl unlegiert	< 800 N/mm2	1.0401	C15	1.0481
	Einsatzstahl legiert	< 1000 N/mm2	1.7331	16MnCr5 (EC80)	1.7015
	Vergütungsstahl unlegiert	< 850 N/mm2	1.0503	C45	1.1191
	Vergütungsstahl unlegiert	< 1000 N/mm2	1.0601	C60	1.1221
	Vergütungsstahl legiert	< 800 N/mm2	1.5131	50MnSi4	1.7030
	Vergütungsstahl legiert	< 1300 N/mm2	1.5755	31NiCr14	1.7033
	Stahlguss	< 850 N/mm2	0.9650	G-X260Cr27	1.6750
	Nitrierstahl	< 1000 N/mm2	1.8504	34CrAl6	1.8507
	Nitrierstahl	< 1200 N/mm2	1.8515	31CrMo12	1.8523
	Wälzlagerstahl	< 1200 N/mm2	1.3505	100Cr6 (W3)	1.3543
	Federstahl	< 1200 N/mm2	1.5026	55Si7	1.7176
	Schnellarbeitsstahl	< 1300 N/mm2	1.3344	S 6-5-3	1.3255
	Werkzeugstahl für Kaltarbeit	< 1300 N/mm2	1.2312	40CrMnMoS8 6	1.2379
	Werkzeugstahl für Warmbeit	< 1300 N/mm2	1.2343	X38CrMoV 5 1	1.2767
	M	Stahl und Stahlguss rostfrei geschwefelt	< 850 N/mm2	1.4305	X8CrNiS18 9
Nichtrostender Stahl, ferritisch		< 750 N/mm2	1.4510	X3CrTi17	1.4528
Nichtrostender Stahl, martensitisch		< 900 N/mm2	1.4034	X46Cr13	1.4116
Nichtrost. Stahl, ferritisch/martensit.		< 1100 N/mm2	1.4313	X3CrNi13-4	1.4028
Nichtrost. Stahl, austenitisch/ferritisch		< 850 N/mm2	1.4460	X8CrNiMo27 5	1.4821
Nichtrostender Stahl, austenitisch		< 750 N/mm2	1.4301	X5CrNi18-10	1.4571
Hitzebeständig		< 1100 N/mm2	1.4747	X80CrNiSi20	1.4876
K	Grauguss mit Lammellengraphit	100-350N/mm2	0.6010	GG10	0.6025
	Grauguss mit Lammellengraphit	300-1000N/mm2	0.6030	GG30	0.6045
	Kugelgraphitguss	300-500N/mm2	0.7040	GGG40	0.7050
	Kugelgraphitguss	550-800N/mm2	0.7060	GGG60	0.7080
	Temperguss weis	350-450N/mm2	0.8035	GTW35	0.8045
	Temperguss weis	500-650N/mm2	0.8055	GTW55	0.8065
	Temperguss schwarz	350-450N/mm2	0.8135	GTS35	0.8145
Temperguss schwarz	500-700N/mm2	0.8155	GTS55	0.8170	
N	Aluminium (unlegiert, niedrig legiert)	< 350 N/mm2	3.0255	Al99,5	3.3308
	Aluminiumlegierungen < 0,5% Si	< 500 N/mm2	3.0515	AlMn1	3.1355
	Aluminiumlegierungen 0,5-10% Si	< 400 N/mm2	3.2152	GD-AlSi6Cu4	3.2373
	Aluminiumlegierungen 10-15% Si	< 400 N/mm2	3.2381	G-AlSi10Mg	3.5562
	Aluminiumlegierungen > 15% Si	< 400 N/mm2		G-AlSi17Cu4	
	Kupfer (unlegiert, niedrig legiert)	< 350 N/mm2	2.0060	E-Cu57	2.0090
	Kupfer-Knetlegierungen	< 700 N/mm2	2.0240	CuZn15	2.0265
	Kupfer-Sonderlegierungen	< 200 HB	2.0916	CuAl5	2.1525
	Kupfer-Sonderlegierungen	< 300HB	2.0978	CuAl11Ni6Fe5	
	Kupfer-Sonderlegierungen	> 300 HB	2.1247	CuBe2F125	
	Messing kurzspanend, Bronze, Rotguss	< 600 N/mm2	2.0360	CuZn40 (Ms60)	2.0380
	Messing langspanend	< 600 N/mm2	2.0335	CuZn36 (Ms63)	2.1293
	Thermoplaste			Delrin, Hostalen	
	Duroplaste			Ferrozell, Bakelit	
	Faserverstärkte Kunststoffe			GFK (Glasfaserverstärkt)	
	Magnesium und Magnesiumlegierungen	< 850 N/mm2	3.5200	M2, MgMn2	3.5612
	Graphit			C8000, R8500X	
Wolfram und Wolframlegierungen			W-NiFe (Densimet W)		
Molybdän und Molybdänlegierungen			Mo , Mo-50Re		
S	Reinnickel		1.3911	RNi24	1.3927
	Nickellegierungen		1.3912	Ni36 (Invar)	1.3924
	Nickellegierungen	< 850 N/mm2	2.4360	S-NiCu 30 Fe	
	Nickel-Chromlegierungen		2.4886	SG-NiMo16Cr16W	2.4610
	Nickel- und Kobaltlegierungen	< 1300 N/mm2	2.4632	NiCr20Co18Ti	2.4631
	Nickel- und Kobaltlegierungen	< 1300 N/mm2	2.4634	NiCo20Cr15MoAlTi	2.4654
	Hochwärmfeste Legierungen	< 1300 N/mm2		Hardox 400	1.4939
	Nickel-Kobalt-(Chrom-)legierungen	< 1400 N/mm2	2.4806	SG-NiCr20Nb, Inconel 82	2.4851
	Reintitan	< 900 N/mm2	3.7025	Ti99,8	3.7034
	Titanlegierungen	< 700 N/mm2	3.7114	TiAl5Sn2	3.7174
H	Titanlegierungen	< 1200 N/mm2	3.7164	TiAl5V4	3.7144
	Stahl gehärtet	< 45 HRc			
		46-55HRc			
		56-60 HRc			
	61-65 HRc				
	65-70 HRc				

SYSTEM 500

Nut- und Trennfräsen

groove milling
and slotting cutter

Technische Hinweise

Schnittdaten

Technical instructions,
cutting data

Werkstoffbezeichnung	Werkstoff- Nr	Werkstoffbezeichnung	Vc (m/min.)	fz (mm)	mit/with AL41F
St52-3	1.0060	St60-2	160-240	0,05 - 0,15	Haupt-Anwendung
45S20	1.0757	46SPb2		0,05 - 0,15	
17Mn4	1.1141	C15E (CK15)		0,05 - 0,15	
13Cr3 (EC60)	1.5919	15CrNi6	70-150	0,05 - 0,12	
Ck45	1.0535	C55		0,05 - 0,12	
Ck60	1.0540	C50		0,05 - 0,12	
28Cr4	1.7225	42CrMo4	50-70	0,05 - 0,15	
34Cr4	1.3565	48CrMo4		0,02 - 0,1	
GS-20NiCrMo3 7	1.6582	GS-34 CrNiMo 6		0,05 - 0,15	
34AlMo5	1.8509	41CrAlMo7	80-120	0,03 - 0,12	
39CrMoV19 3	1.8550	34 CrAlNi 7		0,02 - 0,1	
X192CrMo17	1.3520	100 CrMn 6 (W4)		0,02 - 0,1	
55Cr3	1.7701	51CrMoV4	60-130	0,02 - 0,1	
S 18-1-2-5	1.3294	PMHS6-5-3-8; ASP30		0,02 - 0,1	
X155CrVMo12 1	1.2316	X38CrMo16; RAMAX		0,02 - 0,1	
X45NiCrMo4	1.2842	90MnCrV8	80-150	0,02 - 0,1	
X4CrMoS18	1.4107	GX8CrNi12		0,03 - 0,12	
X105CrCoMo18 2	1.4016	X6Cr17		0,05 - 0,15	
X50CrMoV15	1.4106	X2CrMoSi18-2-1	Haupt-Anwendung	0,02 - 0,1	
X30Cr13	1.4104	X14CrMoS17		0,02 - 0,1	
X20CrNiSi25 4	1.4462	X2CrNiMoN22-5-3 (Duplex)		0,02 - 0,1	
X6CrNiMoTi17 12 2	1.4449	X3CrNiMo18-12-3	Haupt-Anwendung	0,02 - 0,1	
X10NiCrAlTi32-21	1.4825	GX25CrNiSi18-9		0,02 - 0,1	
GG25				0,03 - 0,15	
GG45			80-150	0,03 - 0,15	
GGG50				0,03 - 0,15	
GGG80				0,03 - 0,15	
GTW45			Haupt-Anwendung	0,03 - 0,15	
GTW65				0,03 - 0,15	
GTS45				0,03 - 0,15	
GTS70			Haupt-Anwendung	0,03 - 0,15	
Al99,9Mg0,5	3.0256	E-Al H		0,05 - 0,15	
AlCuMg2	3.3315	AlMg1		0,05 - 0,15	
GD-AlSi9Mg	3.2134	GD-AlSi5Cu1Mg	500-700	0,05 - 0,15	
G-MgAl6	3.2525	S-AlSi12		0,05 - 0,15	
G-AlSi25CuNiMg		G-AlSi21CuNiMg		0,05 - 0,15	
SF-Cu	2.1522	CuSi2Mn	200-500	0,05 - 0,15	
CuZn30	2.0321	CuZn37		0,05 - 0,15	
CuSi3Mn		Ampco 8-16		0,05 - 0,15	
		Ampco18-26	80-220	0,05 - 0,15	
		Ampco M-4		0,05 - 0,15	
CuZn39Pb2 (Ms58)	2.0410	CuZn44Pb2		0,05 - 0,15	
CuCrZr	2.1080	CuSn6Zn6	Haupt-Anwendung	0,05 - 0,15	
Makrolon, Novodur		Acrylglas, Polystyrol		0,05 - 0,25	
Pertinax		Resopal		0,05 - 0,25	
CFK (Kohlefaserverstärkt)		AFK (Amidfaserverstärkt)	100-350	0,05 - 0,15	
MgAl6Zn1	3.5812	MgAl8Zn1		0,02 - 0,1	
R8650		Technograph15		0,05 - 0,15	
W-Cu80/20		W93NiFe (DENAL)	Haupt-Anwendung	0,02 - 0,1	
TZC, TZM		MHC, ODS		0,02 - 0,1	
RNi8	1.3926	RNi12		0,005 - 0,07	
Ni54	1.3921	Ni49	40-120	0,005 - 0,07	
NiCu 30 Fe		Monel 400		0,005 - 0,07	
NiMo16Cr16Ti		Hastelloy C-276		0,005 - 0,07	
NiCr20TiAl		Nimonic 80	Haupt-Anwendung	0,005 - 0,07	
NiCr19Co14Mo4Ti		Waspaloy		0,005 - 0,07	
X12CrNiMo12	1.4980	X6NiCrTiMoVB25-15-2		0,005 - 0,07	
NiCr23Fe, Inconel 601	2.4667	SG-NiCr19NbMoTi	Haupt-Anwendung	0,005 - 0,07	
Ti99,7	3.7064	Ti99,5		0,005 - 0,07	
TiAl6V6Sn2	3.7124	TiCu2		0,005 - 0,07	
TiAl6Sn2Zr4Mo2	3.7154	TiAl6Zr5	Haupt-Anwendung	0,005 - 0,07	
				0,003 - 0,05	
				0,002 - 0,05	
			30-80	0,001 - 0,05	
				-	
				-	





rotaline



Ausspindeln ab \varnothing 0.4 mm

Precision boring starting at \varnothing 0.4 mm

ROTALINE

Ausspindeln
ab Ø 0.4 mm

precision boring
starting at Ø 0.4 mm

Übersicht

summary



Allgemeine Beschreibung

general instructions

... 462



Rotaline

Rotaline

**Maße
dimensions**

**Seite
page**

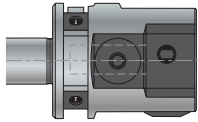

ROTA-HSP0410
Abmessungen und Merkmale

ROTA-HSP0410
characteristics

... 463

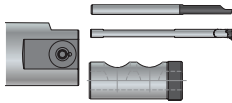

**Aufbau
Reduzierhülsen**

**configuration
reducing sleeves**

... 464



HM-Ausdrehschneiden
D min. 0.4 – 10.4 mm

carbide mini boring tool
D min. 0.4 – 10.4 mm

... 465



HM-Ausdrehschneiden
D min. 9.3 – 15.8 mm

carbide mini boring tool
D min. 9.3 – 15.8 mm

... 466

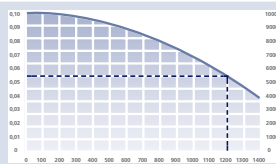

Technische Hinweise

Technical Instructions

**Seite
page**

Ersatzteile /
maximale Drehzahlen

spare parts /
max. rpm

... 467

Schnittdaten

cutting data

... 468

Hartmetallsorten und Beschichtungen

carbide grades and coatings

... 469

ROTALINE

Ausspindeln
ab \varnothing 0.4 mm

precision boring
starting at \varnothing 0.4 mm

Allgemeine Beschreibung

general instruction

rotaline

ROTA-HSP0410 Anwendungsbeispiel

ROTA-HSP0410 exemplary application



Verbessern Sie jetzt Präzision, Qualität und Effizienz bei der Fertigbearbeitung kleinster Bohrungen. Mit unserem neuen, universellen Highspeed Feindrehwerkzeug mit integrierter Digitalanzeige für die Bearbeitung von Bohrungen ab \varnothing 0.4 mm.

- Max. zulässige Drehzahl 35 000/min
- Körperdurchmesser 40 mm
- Auf Grund geringer Baumaße hervorragend geeignet zum Einsatz auf kompakten Maschinen ab Spindelgröße HSK 40.

Ergänzt werden die Werkzeuge durch ein komplettes Zubehörprogramm, das eigens für dieses Werkzeug konzipiert wurde – flexibel, effizient, μ -genau.

Überzeugen Sie sich selbst von der Leistungsfähigkeit des Highspeed Werkzeugs.

You can now improve precision, quality and efficiency when finish boring smallest diameters. With our new, universal high speed precision boring tool with integrated digital display for boring operations from a diameter of 0.4 mm.

- Max. permissible speed of 35 000/min
- Body diameter 40 mm
- Due to its small size this tool is ideally suited for compact machines from a spindle size of HSK 40.

The tool is augmented by a complete range of accessories, which have been designed for this tool – flexible, efficient and extremely accurate.

Check out the performance of the high-speed tools for yourself – come and try us out!



ROTALINE

Ausspindeln
ab $\varnothing 0.4$ mm

precision boring
starting at $\varnothing 0.4$ mm

Abmessungen und Merkmale

characteristics

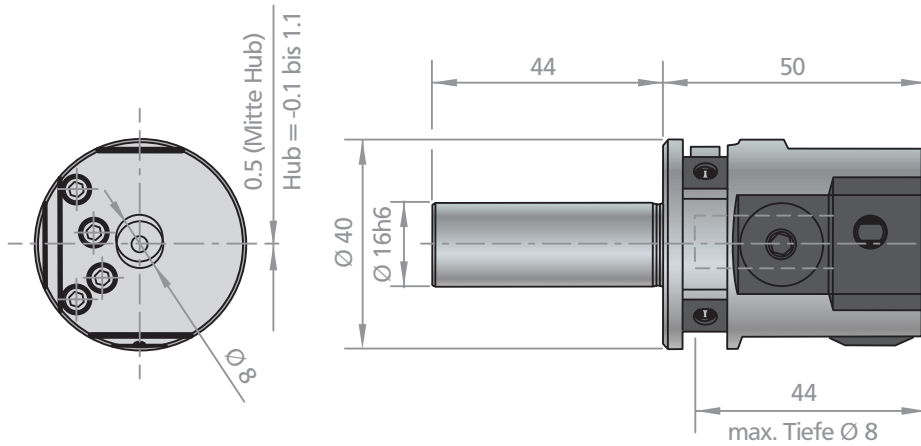

Gewicht / weight
kg

0.42

Ausdrehbereich / boring range
A

$\varnothing 0.4 - \varnothing 15$

- Einfachste Handhabung dank Digitalanzeige.
- Zustellgenauigkeit 0.002 mm im Durchmesser.
- 1,2 mm radiale Hubverstellung.
- Stufenlos axial einstellbare Schneiden.
- Automatisch definierte Schneidenlage.
- Zylindrischer Schaft für flexible Anwendungen.
- Innere Kühlschmierstoffzufuhr (max. 40 bar).
- Manuelle Feinwuchtung über Ausgleichsgewichte.
- Wasser- und staubgeschützt gemäß IP65.
- Nicht im Hydrodehnspannfutter einsetzen!

- Easiest possible handling thanks to digital display.
- Feed-in accuracy 0.002 mm in diameter.
- 1.2 mm radial stroke adjustment.
- Continuously variable axially-adjustable cutting tools.
- Automatically defined cutting edge position.
- Cylindrical shaft for flexible applications.
- Internal coolant supply (max. 40 bar).
- Manual precision balancing through balancing weights.
- Protected against water and dust according to IP65
- Don't use in a hydraulic expansion chuck!

ROTALINE

Ausspindeln
ab $\varnothing 0.4$ mm

precision boring
starting at $\varnothing 0.4$ mm

Aufbau / Reduzierhülse

configuration / reducing sleeves

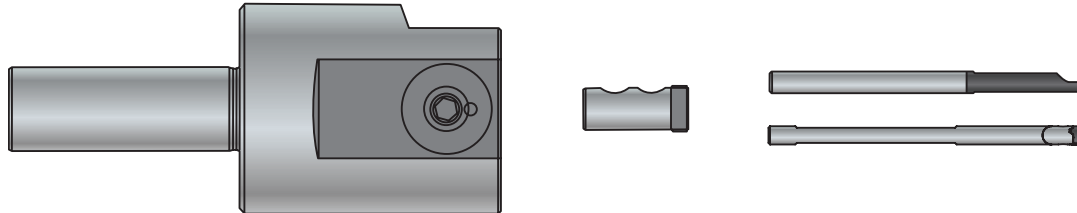

Ausspindelkopf precision boring tool	Reduzierhülse reducing sleeve	HM-Ausdrehschneide mini boring tool	
ROTA-HSP0410	RB04-ROTA	ROTA04-020 R ROTA06-030 R ROTA08-040 R ROTA10-050 R ROTA15-075 R ROTA20-100 R ROTA25-125 R ROTA28-140 R ROTA35-180 R ROTA40-200 R	
	RB05-ROTA	ROTA50-255 R	
	RB06-ROTA	ROTA60-320 R	
	RB07-ROTA	ROTA70-405 R	
	—	ROTA80-505 R	
	RB06-ROTA	V08.006.2 HM	RS08.1846.02
		V11.008.2 HM	RS11.1855.02 RS11.1867.02

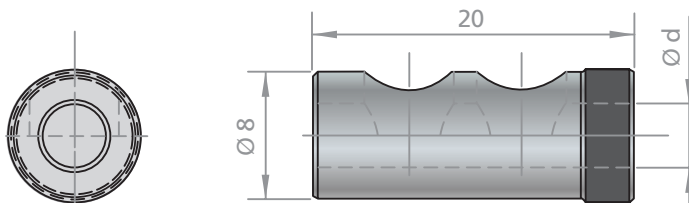

Best. Nummer part number	d		
RB04-ROTA	4		
RB05-ROTA	5		
RB06-ROTA	6		
RB07-ROTA *	7	* ohne IK	* without IK

ROTALINE

Ausspindeln
ab \varnothing 0.4 mm

precision boring
starting at \varnothing 0.4 mm

HM-Ausdrehschneiden

D min. 0.4 - 10.4 mm

carbide mini boring tool

D min. 0.4 - 10.4 mm

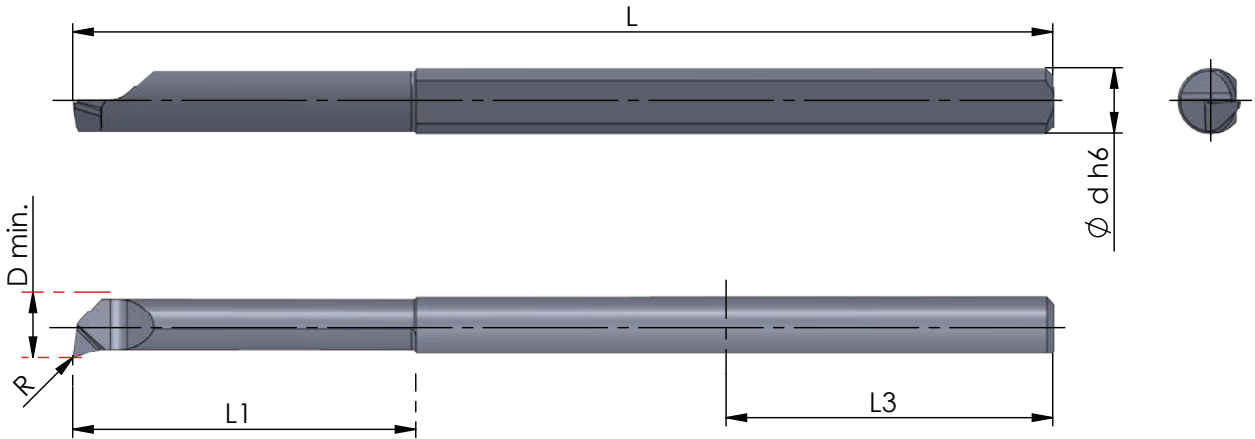

Best. Nummer part number	D min.	\varnothing d h6	L	L1	R	L3 Mindest- einspannlänge min. clamping length	Standard Ausführung basic version
ROTA04-020 R	0.4	4	42.0	2.0	0.03	20	AL41F XC2A-NH
ROTA06-030 R	0.6	4	43.0	3.0	0.04	20	
ROTA08-040 R	0.8	4	44.0	4.0	0.04	20	
ROTA10-050 R	1.0	4	45.0	5.0	0.05	20	
ROTA15-075 R	1.5	4	47.5	7.5	0.05	20	
ROTA20-100 R	2.0	4	50.0	10.0	0.05	20	
ROTA25-125 R	2.5	4	52.5	12.5	0.05	20	
ROTA28-140 R	2.8	4	54.0	14.0	0.07	20	
ROTA35-180 R	3.5	4	58.0	18.0	0.10	20	
ROTA40-200 R	4.0	4	60.0	20.0	0.10	20	
ROTA50-255 R	5.0	5	66.0	25.5	0.12	20	
ROTA60-320 R	6.0	6	75.0	32.0	0.15	20	
ROTA70-405 R	7.0	7	82.0	40.5	0.20	20	
ROTA80-505 R	8.0	8	92.0	50.5	0.20	20	

AL41F
XC2A-NH

Standardausführung
für die Hartbearbeitung bis 66 HRC

basic version
for hard machining up to 66 HRC

Weitere HM Sorten können Sie in der Sorten-
übersicht im Kapitel "Technische Hinweise" und
der Preisliste finden.

Bestellbeispiel:
für rechte Ausführung und Sorte
ROTA04-020R/AL41F

More carbide grades you can find in the grades
summary in the chapter "technical instructions"
and in the price list.

order-example:
righthand version and grade
ROTA04-020R/AL41F

ROTALINE

Ausspindeln
ab Ø 0.4 mm

precision boring
starting at Ø 0.4 mm

HM-Ausdrehschneiden

carbide mini boring tool

D min. 9.3 - 15.8 mm

D min. 9.3 - 15.8 mm

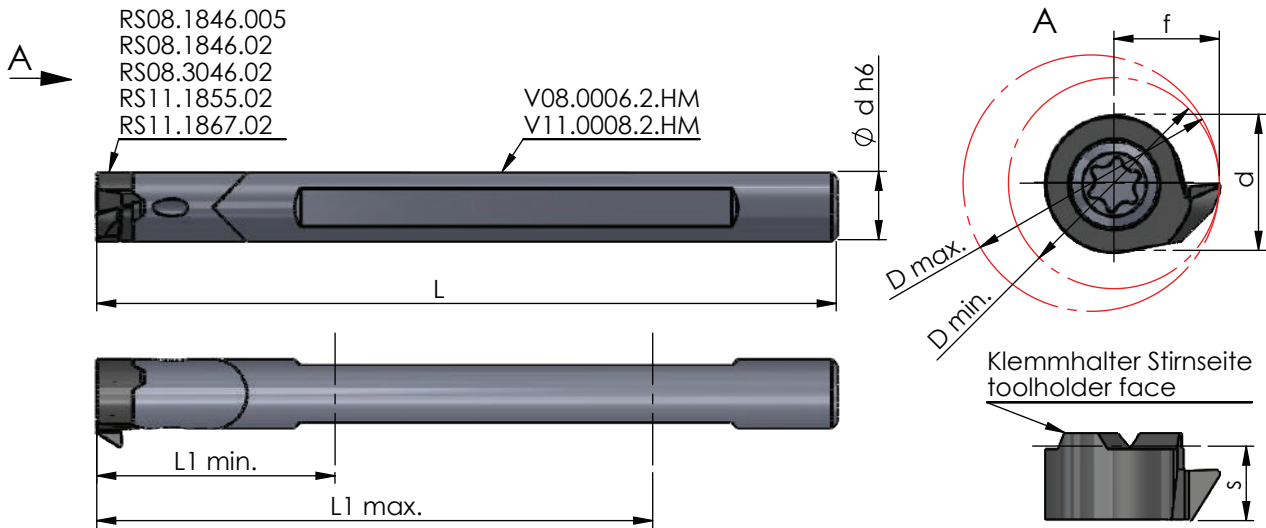

Ausführung rechts (R)

state right (R) version

Abmessungen in mm

dimensions in mm



Bestellnummer part number	D min.	D max.	Ø d h6	L	L1 min.	L1 max.		für Schneidplatte use with insert
V08.0006.2.HM	9.3	11.7	6	65	21	49	- IK	RS08,...
V11.0008.2.HM	11	15.8	8	79	35	63	+ IK	RS11,...

Bestellnummer part number	D min.	D max.	f	s	d	Ap max.*	R	für Halter for holder
RS08.1846.005	9.3	11.7	4.65	3.5	6	0.6	0.5	V08.0006.2.HM
RS08.1846.02	9.3	11.7	4.65	3.5	6	0.6	0.2	
RS08.3046.02	9.3	11.7	4.65	3.5	6	0.6	0.2	
RS11.1855.02	11.0	13.4	5.5	4.2	8	1.0	0.2	V11.0008.2.HM
RS11.1867.02	13.4	15.8	6.7	4.2	8	1.0	0.2	

* Ap max. = maximale Schnitttiefe
(werkstoffabhängig)

Achtung: Schneide muss in Richtung
Spannschrauben zeigen!

Ab Ø 12 mm Schneidwerte
um ca. 30% reduzieren!

Weitere HM Sorten können Sie in der Sorten-
übersicht im Kapitel "Technische Hinweise" und
der Preisliste finden.

Bestellbeispiel:
für rechte Ausführung und Sorte AL41F:
RS08.1846.02/AL41F

* Ap. max = maximum depth of cut
(depending on material)

Attention: cutting edge has to face
towards the clamp screw!

From diameter 12 mm reduce cutting
data about 30%!

More carbide grades you can find in the
grades summary in the chapter "technical
instructions" and in the price list.

order-example:
righthand version and grade AL41F:
RS08.1846.02/AL41F

ROTALINE

Ausspindeln
ab Ø 0.4 mm

precision boring
starting at Ø 0.4 mm

Technische Hinweise

Ersatzteile / Maximale Drehzahlen

Technical instructions,
spare parts / max. rpm

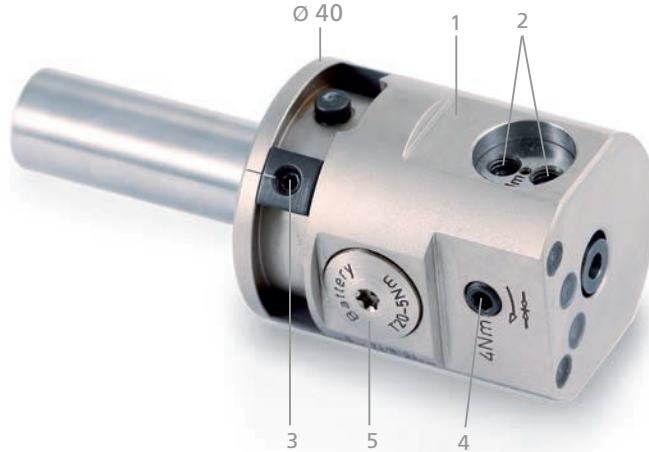

Ersatzteile

spare parts

Teil part	Best. Nummer part number	Schlüssel key	Nummer number	Moment Nm moment Nm
Batterie	ROTA-BAT			
1 Ausspindelkopf	ROTA-HSP0410			
2 Gewindestift	ROTA-M5	T-Schlüssel SW2.5	DS SW25	3
3 Gewindestift	ROTA-M4	T-Schlüssel SW2	DS SW20	2.5
4 Gewindestift	ROTA-M6	T-Schlüssel SW3	DS SW30	4
5 Batteriefachdeckel	ROTA-DCK	Torx T20	TORX T20F	5
Dichtung für Batteriefachdeckel	ROTA-DIC			

Maximale Drehzahl

max. rpm

Ausdrehbereich boring range Ø mm	Auskraglänge overhang length	Max. zulässige Drehzahl max. rpm (1/min)
0.4 - 6.0	max. zulässig max.	35.000
6.0 - 12.0	< 5x Schaft-Ø < 5x shank-Ø	35.000
6.0 - 12.0	> 5x Schaft-Ø > 5x shank-Ø	25.000

ROTALINE

Ausspindeln
ab Ø 0.4 mm

precision boring
starting at Ø 0.4 mm

Technische Hinweise

Schnittdaten

Technical instructions,
cutting data

zu bearbeitender Werkstoff	Ausdrehbereich	Schnittgeschw. Vc = m/min (gilt für ausgewuchtete Werkzeuge)	Vorschub
machining material	boring range	cutting speeds Vc = m/min (only for balanced tools)	feed
Stahl unlegiert steel unalloyed	0.4 - 1.0 1.0 - 8.0	30 - 100 60 - 180	0.01 - 0.02 0.02 - 0.06
Stahl legiert steel alloyed	0.4 - 1.0 1.0 - 8.0	30 - 100 60 - 150	0.01 - 0.02 0.02 - 0.06
Stahl hochlegiert steel high alloyed	0.4 - 1.0 1.0 - 8.0	30 - 100 60 - 120	0.01 - 0.02 0.02 - 0.06
Stahl rostfrei steel stainless	0.4 - 1.0 1.0 - 8.0	30 - 80 40 - 130	0.01 - 0.02 0.02 - 0.06
Grauguß cast iron	0.4 - 1.0 1.0 - 8.0	30 - 100 50 - 170	0.01 - 0.02 0.02 - 0.06
Sphäroguß spheroidal graphite cast iron	0.4 - 1.0 1.0 - 8.0	30 - 100 50 - 170	0.01 - 0.02 0.02 - 0.06
Aluminium Leg. langspanend aluminium alloy, long-chipped	0.4 - 1.0 1.0 - 8.0	40 - 200 180 - 600	0.01 - 0.02 0.02 - 0.06
Aluminium Leg. kurzspanend aluminium alloy, short-chipped	0.4 - 1.0 1.0 - 8.0	40 - 200 180 - 600	0.01 - 0.02 0.02 - 0.06
Warmfeste Legierungen high temperature alloy	0.4 - 1.0 1.0 - 8.0	20 - 60 30 - 80	0.01 - 0.02 0.02 - 0.06
geh. Stahl bis 66 HRC hardend steel to 66 HRC	0.4 - 1.0 1.0 - 8.0	50 - 100 50 - 100	0.01 - 0.02 0.02 - 0.06



Nicht ausgewuchtete Werkzeuge sollten mit stark reduzierter Schnittgeschwindigkeit gefahren werden.

Not balanced tools should work with drastically reduced cutting speed.

ROTALINE

Ausspindeln
ab Ø 0.4 mm

precision boring
starting at Ø 0.4 mm

Technische Hinweise

Hartmetallsorten und Beschichtungen

Technical instructions,
carbide grades and coatings

K10F

Universell einsetzbares Feinkornhartmetall mit guter Verschleißfestigkeit. Unbeschichtet geeignet für Anwendungen mit niedrigen und mittleren Schnittgeschwindigkeiten, sowie die Bearbeitung von Nicht-eisenmetallen.

All purpose micrograin carbide with good abrasion resistance. Uncoated for applications with low or medium cutting speeds and machining of non-ferrous materials.

CBN

Zähe CBN-Sorte für Anwendungen mit niedrigen Schnittgeschwindigkeiten. Geeignet für gehärtete Stähle, unterbrochene Schnitte und Grauguss.

Ductile CBN grade for applications with lower cutting speed. Suitable for hardened steel, interrupted cuts and cast iron.

CN45F

Universell einsetzbare PVD-TiN-Beschichtung. Diese Allround-Sorte ist für niedrige und mittlere Schnittgeschwindigkeiten mit Einschränkung bei NE-Metallen

PVD-TiN coating - all purpose, all around grade is suitable for low and medium cutting speed with restrictions on non-ferrous materials.

AL41F

Sehr universell einsetzbare TiAlN-Beschichtung mit hoher Temperaturbeständigkeit bei hoher Härte. Sehr gut geeignet auch für NE-Metalle.

TiAlN coating - very universal with a high resistance to high temperature and hardness. Very suitable also for non-ferrous metals.

PD2F

Beschichtung für den universellen Einsatz bei niedrigen und mittleren Schnittgeschwindigkeiten.

Coating for universal use with medium and low speed.

XC2A

Beschichtung mit einer excellenten Warmhärte, Oxidationsbeständigkeit und thermischen Isolationsfähigkeit. Ideal für Hartzerspannung >60HRC

Coating with excellent hot hardness, high oxidation resistance and thermal insulation capacity. Perfect for hard machining >60 HRC.



ROTALINE

Ausspindeln
ab \varnothing 0.4 mm

precision boring
starting at \varnothing 0.4 mm

Technische Hinweise

Hartmetallsorten und Beschichtungen

Technical instructions,
carbide grades and coatings

P01C

Beschichtung für die Bearbeitung in zähen Materialien bei niedrigen und mittleren Schnittgeschwindigkeiten.

Coating for the processing in tough material with medium or low cutting speed

P03C

Beschichtung für die Bearbeitung von schwer zerspanbaren Materialien. Sehr gut auch für die Trockenbearbeitung geeignet.

Coating for materials which are difficult to machine. Perfect to use for dry machining.

P07C

Beschichtung für die Bearbeitung von Titan, Edelstahl und Molybdän.

Coating to machine titanium, stainless steel and molybdenum.

P18C

Universell einsetzbare Hochleistungsschicht mit hoher Oxidationsbeständigkeit, Verschleißfestigkeit und Warmhärte.

Very universal high performance coating with high oxidation resistance, wear resistance and hot hardness resistance.

NEME

Beschichtung für die Bearbeitung von Aluminium, Al-Legierungen, NE-Metallen und Composite-Werkstoffen.

Coating for machining aluminium, alloys, non-ferrous metals and composite materials.



Notiz

notice



A large area of the page is filled with horizontal dotted lines, providing a space for writing notes.

Notiz

notice



90 Jahre

Dümme WERKZEUGFABRIK

Zertifiziert nach / certified to
DIN EN ISO 9001: 2015

MINDESTBESTELLMENGE
für Schneidplatten beträgt
die Mindestbestellmenge
2 Stück, für Halter 1 Stück.

MINIMUM ORDER QUANTITY
for inserts the minimum order
quantity is 2 pieces,
for toolholders 1 piece.

MINDESTBESTELLWERT
der Mindestbestellwert pro
Auftrag beträgt € 80,- Netto
(ausschließlich Umsatzsteuer).
Für Aufträge unter € 80,-
berechnen wir einen Zuschlag
für Kleinaufträge in Höhe
von € 20,-.

MINIMUM ORDER VALUE
the minimum order value for
one order is € 80,- net.
(excluded sales tax).
For orders less than € 80,-
we have an additional order
charge of € 20,-.

© Stand 09/2018
Urheberrechtlich geschützt.

© edition 09/2018
copyright reserved.

Katalognachdruck oder
Veröffentlichung auch
auszugsweise verboten.

reprint or publishing of the
catalogue complete or in
extracts prohibited.

Technische Änderungen und
Irrtümer vorbehalten, keine
Gewährleistung für
Druckfehler.

technical changes and errors
reserved, no warranty for
missprints.